

Makita[®]

2021 GENERAL CATALOGUE (TOOLS)



40V max **XGT**

KEY TO SYMBOLS

Double Insulation		Adapted for SDS-PLUS bits	
Variable Speed		Adapted for SDS-MAX Bits	
Constant Speed		13mm Hex Shank Drive	
Reversing		17mm Hex Shank Drive	
Mechanical 2-Speed		21mm Hex Shank Drive	
Mechanical 3-Speed		28.6mm Hex Shank Drive	
Electronic 2-Speed		30mm Hex Shank Drive	
Electronic 3-Speed		Spline Shank	
Electronic 4-Speed		Anti Vibration	
Brake		Bevel Cutting 45L R5	
Torque Setting 6		Bevel Cutting 45L	
Torque Setting 9		Bevel Cutting 45LR	
Torque Setting 16		Bevel Cutting 56L	
Torque Setting 18		Laser Marker	
Torque Limiter		Auto Firing Stop	
Built-in Job Light		Automatic Oiling	
Soft Start		Chain Brake	
Keyless Chuck		Decompression Valve	
Dust Collecting		Primer Pump	
Bayonet Shank Jig Saw Blade		Capacitor Discharge Ignition	
Makita Shank Jig Saw Blade		Rapid Start	
Orbital Cutting		Revolving Hose	
Dial Depth Adjusting		Stainless Tank	
Hook & Loop		Paper Filter	
Induction Motor		Static Free Hose	
Oil Sensor		Remote Control	
Auto Decompression		Carrying Case	



THE CORDLESS ANSWER TO HIGH DEMANDS

XGT is a new system with its own tools, batteries, and chargers

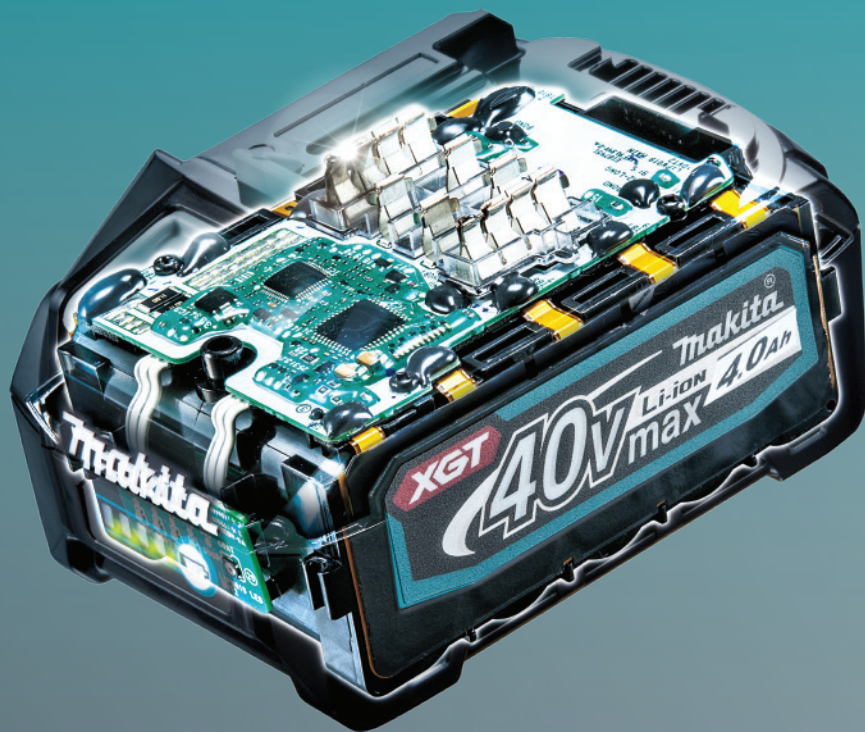

HIGH BATTERY OUTPUT

XGT is a genuine solution for high demand Industrial applications, A combination of innovative tool design and higher output batteries, providing a genuine solution for high demand industrial users as well!



SMART TECHNOLOGY

The XGT range of tools and batteries come with a built-in program, providing digital communication between the battery and tool. Allowing not only for the battery to talk with tool but also the tool to talk to the battery.



BUILT TOUGH

XGT is durable and built to perform! XGT batteries and tools are built to withstand tough environmental conditions such as impacts and splashing or spraying water from any angle.



FUTURE PROOF

XGT and LXT will co-exist to provide users with an unmatched line-up of cordless tools for professional trade applications all the way up the high demand Industrial applications.



Optimum Charging System

Rapid Optimum Charger

It is necessary to cool down before start charging when the battery temperature is high. Built-in fan circulates air through the battery before start charging and during the charging process to cool the battery for faster charge time.

The Makita Rapid Optimum Charger communicates with the battery's built-in chip throughout the charging process to optimize battery life by actively controlling current, voltage and temperature.

The optimum charging system
Forced air cooling

General charging method
Natural heat dissipation



Fast charging

Waiting time for charging



The optimum charging system

General charging method

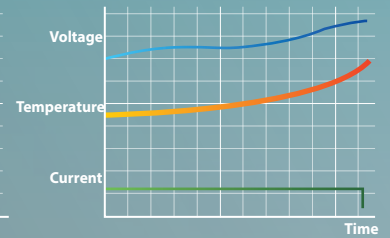
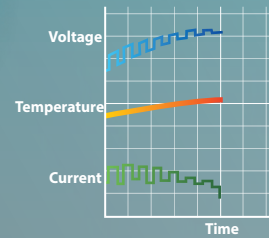

Battery Protection Function

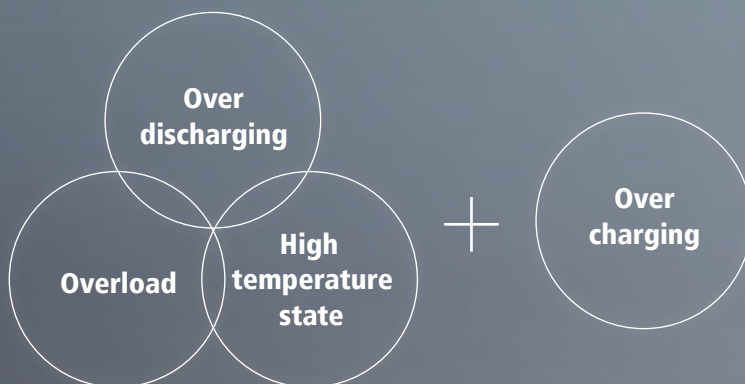

This function is communication technology that allows the tool and battery to monitor conditions and exchange data in real time to protect against Overload, Over-Discharge and Overheating.

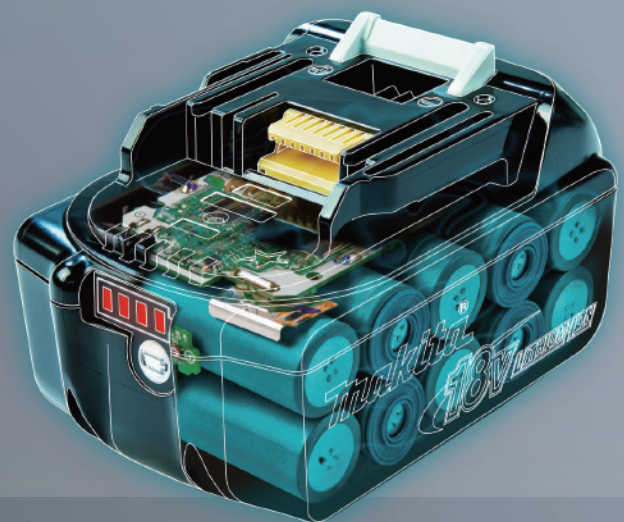

Anytime Charge
No Memory Effect
No discharging required



Shock Absorbing
Heavy Duty Pack



AFT

Active Feedback sensing Technology (AFT)

- Smart function to minimize the danger of kick-back
- Shuts down the tool if the rotation speed suddenly slows down

Note: The function of AFT is not to prevent the occurrence of kickback

ADT

Automatic torque Drive Technology (ADT)

Automatically changes the speed according to load conditions for an optimum operations:

AVT

Anti Vibration Technology (AVT)

The benchmark in vibration reduction Makita demolition tools are among the best in the world. Working with the users to solve the problem of vibration Makita's AVT products have been designed in close relation to users needs at site level.



XPT

EXTREME PROTECTION TECHNOLOGY

Extreme Protection Technology (XPT)

For use in outdoor applications or harsh environments, protection from dust and dripping water.

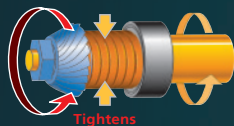

SUPER JOINT SYSTEM

With the rotation of armature shaft, Coil-Spring is extended and its tightening force increases so that armature shaft is fixed firmly and transmitted to spiral bevel gear.

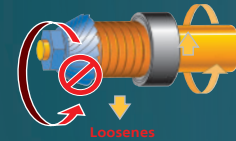

If the grinding wheel catches or binds, the coil spring relaxes and disengages the gears from the motor. As the grinding wheel stops, the gears and motor are protected.

SUPER JOINT SYSTEM (SJS II)



SJS II provides a leaf spring and cam gear drive mechanism that is engineered to reduce vibration for increased operator comfort during extended use



DEEP AND EXACT CUTTING TECHNOLOGY

DXT

Deep and Exact Cutting Technology (DXT) is a series of features that give Makita miter saws more cutting capacity and out-of-the-box accuracy for superior cutting performance.

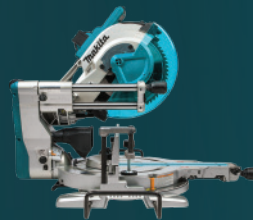

MM4

MAKITA MINI 4 STROKE ENGINE (MM4)

Makita's proven 4-Stroke engines offer: High performance, compact and light weight design, clean exhaust emissions, low running cost, easy maintenance and low noise advantages compared with equivalent size of 2-Stroke Engines.

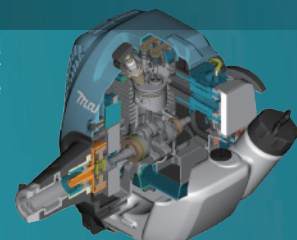

INDEX

CORDLESS TOOLS	T 015	SANDING / POLISHING	T 204	GARDEN TOOLS	T 268
Lithium-ion Battery and Charger Reference Chart	T 018	Disc Sander	T 205	Multi Function Power Head	T 271
XGT 40V MAX - Lithium-ion Cordless Tools	T 022	Polisher	T 205	Chain Saw	T 274
18V+18V LXT - Lithium-ion Cordless Tools	T 032	Sander-Polisher	T 206	Telescopic Pole Saw	T 278
18V LXT - Lithium-ion Cordless Tools	T 058	Random Orbit Polisher	T 206	Pruning Shears	T 279
14.4V LXT - Lithium-ion Cordless Tools	T 105	Angle Sander	T 207	Hedge Trimmer	T 280
12V MAX CXT - Lithium-ion Cordless Tools	T 106	Stone Polisher	T 207	Grass Trimmer / String Trimmer / Brush Cutter	T 283
7.2V LXT - Lithium-ion Cordless Tools	T 122	Belt Sander	T 207	Edger	T 287
3.6V Lithium-ion Cordless Tool	T 123	Wheel Sander	T 209	Grass Shear	T 288
18V G-series - Lithium-ion Cordless Tools	T 125	Finishing Sander	T 210	Blower	T 289
14.4V G-series - Lithium-ion Cordless Tools	T 126	Orbital Sander	T 211	Lawn Mower	T 294
Comfort @ Work	T 127	Random Orbit Sander	T 212	Submersible Pump	T 298
FIXING / FASTENING	T 139	SAWING	T 214	Sprayer	T 299
Drywall Screwdriver	T 140	Slide Compound Miter Saw	T 215	Wheel Barrow	T 299
Screwdriver	T 141	Compound Miter Saw	T 216	GENERATORS	T 300
Auto Feed Screwdriver	T 142	Miter Saw	T 217	Generators	T 300
Tapper	T 142	Table Top Miter Saw	T 217	Makita Gulf Authorized distributors	T 306
Impact Driver	T 142	Flip Over Saw	T 218		
Impact Wrench	T 142	Table Saw	T 218		
DRILLING / IMPACT DRILLING	T 144	Circular Saw	T 219		
Driver Drill	T 145	Plunge Cut Circular Saw	T 221		
High Speed Drill	T 145	Jig Saw	T 222		
Drill	T 145	Scroll Saw	T 224		
Diamond Core Drill	T 146	Reciprocating Saw	T 224		
Angle Drill	T 149	Band Saw	T 225		
Drill Press	T 149	ROUTING / PLANING	T 226		
Magnetic Drill	T 149	Power Planer	T 227		
Power Mixer	T 150	Planer / Thicknesser	T 229		
Impact Drill	T 151	Plate Joiner	T 229		
2-Speed Impact Drill	T 154	Trimmer	T 229		
CONCRETE DRILLING / DEMOLITION	T 155	Router	T 230		
SDS-PLUS Rotary / Combination Hammers	T 161	Sash Router	T 231		
SDS-MAX Rotary / Combination Hammers	T 166	Cut-out tool	T 231		
17mm Hex Shank Rotary Hammers	T 166	CLEANING	T 232		
Chipping Hammers	T 170	AC Vacuum Cleaner	T 234		
Demolition Hammers	T 170	DC Upright Vacuum Cleaner	T 236		
Electric Breaker	T 173	DC Vacuum Cleaner	T 237		
Power Scraper	T 174	DC Backpack Vacuum Cleaner	T 239		
CUTTING [CONCRETE / MASONRY / METAL]	T 175	DC Robotic Cleaner	T 241		
Angle Cutter	T 176	DC Cyclonic Cleaner	T 242		
Power Cutter	T 176	DC Stick Type Cleaner	T 243		
Tile Cutter	T 178	DC Cleaner + Blower	T 245		
Wall Chaser	T 179	Dust Collecting Chart with Power Tools	T 247		
Metal Cutter	T 180	High Pressure Washer	T 255		
Aluminum Groove Cutter	T 180	HEAT GUN	T 257		
Portable Band Saw	T 181	Heat Gun	T 258		
Metal Cutting Saw	T 181	LASER	T 259		
Portable Cut-off Saw	T 181	Cross line Laser - CXT	T 260		
Shears	T 183	Multiline Laser - CXT	T 261		
Nibblers	T 184	Laser Distance Measure	T 262		
MULTI TOOL	T 185	Rotating Laser Level	T 263		
Multi Tool (Cordless and Corded)	T 186	Cross line Laser Level	T 264		
GRINDING	T 187	PNEUMATIC TOOLS	T 265		
Angle Grinder	T 190	Pneumatic Stapler	T 266		
Die Grinder	T 199	Pneumatic Brad Nailer	T 266		
Straight Grinder	T 201	Pneumatic Coil Nailer	T 267		
Bench Grinder	T 202	Pneumatic Micro Pinner	T 267		
Concrete Planner	T 203				

1		
1100	Power Planer	T 227
1805N	Power Planer	T 228
1902	Power Planer	T 227
1911B	Power Planer	T 228
2		
2012NB	Planer / Thicknesser	T 229
2107FK	Portable Band Saw	T 181/225
2414	Portable Cut Off	T 181
2414B	Portable Cut Off	T 181
2416S	Portable Cut Off	T 182
2703	Table Saw	T 218
2704N	Table Saw	T 218
2712	Table Saw	T 219
3		
3601B	Router	T 230
3612BR	Router (Plunge Type)	T 230
3700B	Trimmer	T 229
3706	Cut-out Tool	T 231
3709	Trimmer	T 220
4		
4100NH	Cutter	T 178
4107R	Cutter	T 178
4112HS	Angle Cutter	T 176
4131	Metal Cutter	T 180
4300BA	Jigsaw	T 222
4300BV	Jigsaw	T 222
4326	Jigsaw	T 222
4327	Jigsaw	T 222
4329	Jigsaw	T 223
4350CT	Jigsaw	T 223
4350FCT	Jigsaw	T 223
4351FCT	Jigsaw	T 223
4403	Sash Router	T 231
5		
5007N	Circular Saw	T 219
5103N	Circular Saw	T 221
5143R	Circular Saw	T 221
5201N	Circular Saw	T 220
5402	Circular Saw	T 221
5800NB	Circular Saw	T 219
6		
6010B	Drill	T 145
6010BVR	Drill	T 146
6016	Drill	T 147
6301	Drill	T 148
6305	Drill	T 147
6408	Drill	T 146
6413	Drill	T 146
6501	High Speed Drill	T 145
6801B	Screwdriver	T 141
6806B	Tapper	T 142
6821	Drywall Screwdriver	T 140
6827	Screwdriver	T 141
6842	Auto Feed Screwdriver	T 142
6904VH	Impact Wrench	T 142
6906	Impact Wrench	T 143
6953	Impact Wrench	T 143
8		
8416	Impact Drill	T 154
8419B	2-Speed Impact Drill	T 154
8419B2	2-Speed Impact Drill	T 154
8420V	Impact Drill	T 154
9		
906	Die Grinder	T 199
906H	Die Grinder	T 199
9015B	Angle Grinder	T 192
9031	Belt Sander	T 208
9032	Belt Sander	T 207
9045B	Finishing Sander	T 211
9046	Orbital Sander	T 211
9105	Straight Grinder	T 202
9207SPB	Sander-Polisher	T 206
9218PB	Polisher	T 205
9218SB	Disc Sander	T 205
9237CB	Sander-Polisher	T 206
9401	Belt-Sander	T 209
9403	Belt-Sander	T 209
9404	Belt-Sander	T 209
9520B	Angle Grinder	T 190
9521NB	Angle Grinder	T 190
9522NB	Angle Grinder	T 190
9553HN	Angle Grinder	T 191
9554HN	Angle Grinder	T 191
9555HN	Angle Grinder	T 191
9556HN	Angle Grinder	T 192
9556HP	Angle Grinder	T 192
9557HN	Angle Grinder	T 192
9557HP	Angle Grinder	T 192
9558HN	Angle Grinder	T 192
9558HP	Angle Grinder	T 192
9561CR	Angle Grinder	T 194
9562CR	Angle Grinder	T 194
9563HZ	Angle Grinder	T 193
9564PZ	Angle Grinder	T 194
9564PC	Angle Grinder	T 196
9565HZ	Angle Grinder	T 193
9565PZ	Angle Grinder	T 194
9741	Wheel Sander	T 209
9910	Belt Sander	T 208
9920	Belt Sander	T 208
9924DB	Belt Sander	T 208
A		
ADP05	USB Adapter	T 139
ADP06	USB Adapter	T 139
AF201Z	Pneumatic Micro Pinner	T 267
AF301	Pneumatic Brad Nailer	T 266
AF506	Pneumatic Brad Nailer	T 267
AN613	Pneumatic Coiler Nailer	T 267
AT425B	Pneumatic Stapler	T 266
AT1225BZ	Pneumatic Stapler	T 266
AT1025B	Pneumatic Stapler	T 266
B		
BHX2500	Petrol Blower	T 293
BMR100	Job Site Radio	T 137
BO3700	Finishing Sander	T 210
BO3710	Finishing Sander	T 210
BO4510	Finishing Sander	T 211
BO4556	Finishing Sander	T 211
BO4566	Finishing Sander	T 212
BO4900	Finishing Sander	T 210
BO4901	Finishing Sander	T 210
BO5030	Random Orbit Sander	T 212
BO5041	Random Orbit Sander	T 212
BO6030	Random Orbit Sander	T 212
BO6050J	Random Orbit Sander	T 213
C		
CA5000XJ	Aluminium Groove Cutter	T 180
CB100D	(DC) Heated Blanket	T 130
CC301D	(DC) Cutter	T 113
CG100D	(DC) Caulking Gun	T 116
CF001G	(DC) Fan	T 031/131
CF100D	(DC) Fan	T 131
CF101D	(DC) Fan	T 131
CL106FD	(DC) Cleaner	T 121/244
CL108FD	(DC) Cleaner	T 120/244
CL121D	(DC) Cleaner / Blower	T 120/245
CL183D	(DC) Cleaner	T 125
CLX203AX4	(DC) Combo Kit	T 121
CP100D	(DC) Multi Cutter	T 114
D		
DA332D	(DC) Angle Drill	T 111
DA3010	Angle Drill	T 148
DA4000LR	Angle Drill	T 149
DBM131	Diamond Core Drill	T 148
DBM230	Diamond Core Drill	T 148
DBO180	(DC) Random Orbit Sander	T 084
DBS180	(DC) Belt Sander	T 085
DCB200	(DC) Heated Blanket	T 130
DCF102	(DC) Fan	T 131
DCG180	(DC) Caulking Gun	T 091
DCL180	(DC) Cleaner	T 098/243
DCL184	(DC) Cleaner + Blower	T 097/245
DCL281	(DC) Cleaner	T 098/243
DCL501	(DC) Cleaner	T 097/242
DCM501	(DC) Coffee Maker	T 136
DCO181	(DC) Cut-Out Tool	T 090
DCS553	(DC) Metal Cutter	T 077
DCS5200	Petrol Chain Saw	T 276
DCS7301	Petrol Chain Saw	T 277
DCS7901	Petrol Chain Saw	T 277
DCS9010	Petrol Chain Saw	T 277
DCU180	(DC) Wheel Barrow	T 104/299
DCV200	(DC) Heated Vest	T 130
DDA351	(DC) Angle Drill	T 071
DDA460	(DC) Angle Drill	T 047
DDF446	(DC) Driver Drill	T 105
DDF451	(DC) Driver Drill	T 062
DDF453	(DC) Driver Drill	T 063
DDF481	(DC) Driver Drill	T 062
DDF482	(DC) Driver Drill	T 062
DDF483	(DC) Driver Drill	T 063
DDF484	(DC) Driver Drill	T 062
DDG460	(DC) Driver Earth Auger	T 047
DF001DW	(DC) Screwdriver	T 123
DF001G	(DC) Driver Drill	T 023
DF012DSJ	(DC) Driver Drill	T 122
DF0300	Driver Drill	T 145
DF331D	(DC) Driver Drill	T 109
DF332D	(DC) Driver Drill	T 108
DF333D	(DC) Driver Drill	T 108
DF347D	(DC) Driver Drill	T 126
DF457D	(DC) Driver Drill	T 124
DFJ206	(DC) Fan Jacket	T 128
DFJ207	(DC) Fan Jacket	T 128
DFJ212	(DC) Fan Jacket	T 129
DFJ213	(DC) Fan Jacket	T 129
DFJ214	(DC) Fan Jacket	T 129
DFJ304	(DC) Fan Jacket	T 128
DFJ405	(DC) Fan Jacket	T 128
DFJ407	(DC) Fan Jacket	T 128
DFN350	(DC) Brad Nailer	T 093
DFR550	(DC) Autofeed Screwdriver	T 072
DFS250	(DC) Screwdriver	T 071
DFS452	(DC) Screwdriver	T 071
DFV210	(DC) Fan Vest	T 129
DSL800	(DC) Drywall Sander	T 085
DCE090	(DC) Power Cutter	T 044
DGA469	(DC) Angle Grinder	T 082
DGA452	(DC) Angle Grinder	T 081
DGA454	(DC) Angle Grinder	T 082
DGA455	(DC) Angle Grinder	T 082
DGA456	(DC) Angle Grinder	T 082

DGA458	(DC) Angle Grinder	T 082	DPB182	(DC) Portable Band Saw	T 078	DVC750L	(DC) Vacuum Cleaner / Blower	T 096/241
DGA519	(DC) Angle Grinder	T 082	DPB183	(DC) Portable Band Saw	T 078	DVC860L	(AC + DC) Vacuum Cleaner	T 057/238
DGA700	(DC) Angle Grinder	T 049	DPJ180	(DC) Plate Joiner	T 090	DVC864L	(DC) Vacuum Cleaner	T 056/237
DGA701	(DC) Angle Grinder	T 049	DPO600	(DC) Random Orbit Polisher	T 084	DVF104	(DC) Sprayer	T 10/299
DGA900	(DC) Angle Grinder	T 049	DPP200	(DC) Hole Puncher	T 075	DVP180	(DC) Vacuum Pump	T 091
DGA901	(DC) Angle Grinder	T 049	DPT351	(DC) Pin Nailer	T 093	DWT310	(DC) Shear Wrench	T 048
DGD800	(DC) Die Grinder	T 084	DPT353	(DC) Pin Nailer	T 093	E		
DHK180	(DC) Power Scraper	T 061	DRC200	(DC) Robotic Cleaner	T 095	EA3502S40B	Petrol Chain saw	T 276
DHP446	(DC) Percussion Driver Drill	T 105	DRS780	(DC) Rear Handle Saw	T 051	EA4301F45B	Petrol Chain saw	T 276
DHP451	(DC) Percussion Driver Drill	T 064	DRT50	(DC) Trimmer	T 089	EA6100P	Petrol Chain saw	T 277
DHP453	(DC) Percussion Driver Drill	T 065	DRV150	(DC) Rivet Gun	T 072	EB5300TH	Backpack Petrol Blower	T 293
DHP481	(DC) Percussion Driver Drill	T 064	DS4011	Drill	T 147	EB7660TH	Backpack Petrol Blower	T 293
DHP482	(DC) Percussion Driver Drill	T 064	DS5000	Drill	T 147	EE2650H	Petrol Edger	T 287
DHP483	(DC) Percussion Driver Drill	T 065	DSC102	(DC) Threaded Rod Cutter	T 073	EF1550RH	Petrol Sprayer	T 299
DHP484	(DC) Percussion Driver Drill	T 064	DSC121	(DC) Threaded Rod Cutter	T 073	EG2250A	Generator	T 300
DHR171	(DC) Combination Hammer	T 061	DSC163	(DC) Steel Rod Cutter	T 074	EG2850A	Generator	T 301
DHR182	(DC) Combination Hammer	T 060	DSC250	(DC) Steel Rod Cutter	T 074	EG4550A	Generator	T 301
DHR202	(DC) Combination Hammer	T 060	DSC251	(DC) Steel Rod Cutter	T 074	EG5550A	Generator	T 301
DHR242	(DC) Combination Hammer	T 060	DSD180	(DC) Drywall Cutter	T 088	EG6050A	Generator	T 301
DHR263	(DC) Combination Hammer	T 046	DSP600	(DC) Circular Saw	T 050	EH7500S	Petrol Hedge Trimmer	T 282
DHR280	(DC) Combination Hammer	T 045	DSP601	(DC) Circular Saw	T 050	EH7500W	Petrol Hedge Trimmer	T 282
DHR281	(DC) Combination Hammer	T 045	DST112	(DC) Stapler	T 092	EK6100	Power Cutter	T 176
DHR283	(DC) Combination Hammer	T 045	DST221	(DC) Stapler	T 092	EK7301WS	Power Cutter	T 176
DHR400N	(DC) Combination Hammer	T 044	DTD134	(DC) Impact Driver	T 105	EK7650H	Power Cutter	T 177
DHS660	(DC) Circular Saw	T 087	DTD153	(DC) Impact Driver	T 066	EK7651H	Power Cutter	T 177
DHS661	(DC) Circular Saw	T 087	DTD154	(DC) Impact Driver	T 066	EK8100WS	Power Cutter	T 176
DHS680	(DC) Circular Saw	T 086	DTD171	(DC) Impact Driver	T 066	ELM3320	Lawn Mower	T 296
DHS783	(DC) Circular Saw	T 051	DTM51	(DC) Multi Tool	T 080/186	ELM3720	Lawn Mower	T 296
DHS900	(DC) Circular Saw	T 051	DTP141	(DC) Impact Driver	T 067	ELM4110	Lawn Mower	T 296
DJN161	(DC) Nibbler	T 080	DTR180	(DC) Rebar Tying Tool	T 076	ELM4612	Lawn Mower	T 296
DJR181	(DC) Reciprocating Saw	T 089	DTS141	(DC) Oil Pulse Impact Driver	T 067	ELM4613	Lawn Mower	T 297
DJR185	(DC) Reciprocating Saw	T 089	DTW1001	(DC) Impact Wrench	T 068	EM2500U	Petrol Brush Cutter	T 285
DJR187	(DC) Reciprocating Saw	T 088	DTW181	(DC) Impact Wrench	T 070	EM2650UH	Petrol Brush Cutter	T 286
DJR360	(DC) Reciprocating Saw	T 053	DTW190	(DC) Impact Wrench	T 070	EM4350RH	Backpack Petrol Brush Cutter	T 287
DJS101	(DC) Metal Shear	T 080	DTW285	(DC) Impact Wrench	T 069	EN4950H	Petrol Pole Hedge Trimmer	T 281
DJV180	(DC) Jig Saw	T 088	DTW300	(DC) Impact Wrench	T 069	EZH2000	Backpack Petrol Sprayer	T 299
DK18113X1	G-series Combo Kit	T 125	DTW701	(DC) Impact Wrench	T 068	EX2650LH	Petrol Multi Function Power Head	T 271
DKP180	(DC) Planer	T 090	DTW450	(DC) Impact Wrench	T 068	EY2650H25H	Petrol Telescopic Pole Saw	T 278
DKP181	(DC) Planer	T 090	DUB182	(DC) Blower	T 103/290	F		
DLM382	(DC) Lawn Mower	T 042/294	DUB184	(DC) Blower	T 103/290	FS2300	Drywall Screwdriver	T 140
DLM431	(DC) Lawn Mower	T 042/294	DUB185	(DC) Blower	T 103/290	FS2500	Screwdriver	T 141
DLM460	(DC) Lawn Mower	T 042/295	DUB361	(DC) Blower	T 041/290	FS2700	Screwdriver	T 141
DLM531	(DC) Lawn Mower	T 042/295	DUB362	(DC) Blower	T 041/289	FS4300	Drywall Screwdriver	T 140
DLM532	(DC) Lawn Mower	T 041/295	DUB363	(DC) Blower + Vacuum	T 040/289	FS6300	Drywall Screwdriver	T 140
DLM533	(DC) Lawn Mower	T 041/295	DUC252	(DC) Chain Saw	T 037/275	G		
DLS600	(DC) Lawn Mower	T 086	DUC254	(DC) Chain Saw	T 100/275	GA004G	(DC) Angle Grinder	T 029
DLS111	(DC) Slide Compound Miter Saw	T 052	DUC405	(DC) Chain Saw	T 037/275	GA005G	(DC) Angle Grinder	T 029
DLS211	(DC) Slide Compound Miter Saw	T 052	DUH551	(DC) Hedge Trimmer	T 038/280	GA012G	(DC) Angle Grinder	T 029
DLS713	(DC) Slide Compound Miter Saw	T 086	DUH751	(DC) Hedge Trimmer	T 101/280	GA013G	(DC) Angle Grinder	T 029
DLS714	(DC) Slide Compound Miter Saw	T 052	DUH754S	(DC) Hedge Trimmer	T 101/280	GA022G	(DC) Angle Grinder	T 030
DLW140	(DC) Portable Cut-off	T 048	DUM604	(DC) Grass Trimmer	T 102/288	GA023G	(DC) Angle Grinder	T 030
DLX2248PT1	(DC) LXT Combo Kit	T 099/246	DUN500W	(DC) Pole Hedge Trimmer	T 100/279	GA028G	(DC) Angle Grinder	T 030
DML805	(DC) + (DC) Worklight	T 133	DUP362	(DC) Pruning Shears	T 040	GA029G	(DC) Angle Grinder	T 030
DML809	(AC + DC) Area Worklight	T 132	DUR189	(DC) Grass Trimmer	T 102/285	GA4030	Angle Grinder	T 191
DML810	(AC + DC) Area Worklight	T 132	DUR190	(DC) Grass Trimmer	T 102/285	GA4040CZ	Angle Grinder	T 195
DML811	(AC + DC) Area Worklight	T 133	DUR364L	(DC) Grass Trimmer	T 040/284	GA4040Z	Angle Grinder	T 194
DML812	(DC) LED Flashlight	T 133	DUR369A	(DC) Grass Trimmer	T 039/284	GA4050	Angle Grinder	T 195
DML814	(DC) Area Worklight	T 132	DUR369N	(DC) Grass Trimmer	T 039/284	GA4530	Angle Grinder	T 191
DML815	(DC) LED Flashlight	T 133	DUT130	(DC) Mixer	T 071	GA4540CZ	Angle Grinder	T 195
DMP180	(DC) Inflator	T 135	DUX60	(DC) Multi-Function Power Head	T 036/271	GA4540Z	Angle Grinder	T 194
DMR107	(AC + DC) Jobsite Radio	T 137	DVC150L	(AC + DC) Vacuum Cleaner	T 057/238	GA4550/R	Angle Grinder	T 195
DMR110	(AC + DC) Jobsite Radio	T 137	DVC154L	(DC) Vacuum Cleaner	T 056/237	GA5010	Angle Grinder	T 193
DMR200	(DC) Speaker	T 136	DVC261	(DC) Backpack Vacuum Cleaner	T 055/240	GA5011	Angle Grinder	T 193
DMR203	(DC) Speaker	T 136	DVC265	(DC) Backpack Dust Extractor	T 054/239	GA5030	Angle Grinder	T 191
DP2010	Drill	T 145	DVC350	(DC) Vacuum Cleaner	T 096/242	GA5034	Angle Grinder	T 191
DP4700	Drill	T 146	DVC560	(DC) Upright Vacuum Cleaner	T 053/236	GA5040CZ	Angle Grinder	T 195
DPB180	(DC) Portable Band Saw	T 078	DVC660	(DC) Backpack Vacuum Cleaner	T 055/240	GA5040Z	Angle Grinder	T 194
DPB181	(DC) Portable Band Saw	T 078	DVC665	(DC) Backpack Dust Extractor	T 054/239	GA5050/R	Angle Grinder	T 195

GA6010	Angle Grinder	T 193
GA7001	Angle Grinder	T 196
GA7020	Angle Grinder	T 197
GA7030	Angle Grinder	T 198
GA7040S	Angle Grinder	T 198
GA7050	Angle Grinder	T 196
GA7050R	Angle Grinder	T 197
GA7062	Angle Grinder	T 197
GA7063	Angle Grinder	T 198
GA9020	Angle Grinder	T 197
GA9030	Angle Grinder	T 198
GA9040S	Angle Grinder	T 198
GA9050	Angle Grinder	T 196
GA9050R	Angle Grinder	T 197
GA9062	Angle Grinder	T 197
GA9063	Angle Grinder	T 198
GB602	Bench Grinder	T 202
GB800	Bench Grinder	T 202
GB801	Bench Grinder	T 202
GD0600	Die Grinder	T 199
GD0602	Die Grinder	T 199
GD0800C	Die Grinder	T 200
GD0801C	Die Grinder	T 200
GD0810C	Die Grinder	T 200
GD0811C	Die Grinder	T 200
G55000	Straight Grinder	T 201
G56000	Straight Grinder	T 201
GV6010	Disc Sander	T 205
GV7000C	Disc Sander	T 205
H		
HB500	Electro Magnetic Drill	T 149
HG6030K	Heat Gun	T 258
HG6530V	Heat Gun	T 258
HG6531CK	Heat Gun	T 258
HK0500	Power Scraper	T 174
HK1810	Power Scraper	T 174
HK1820	Power Scraper	T 174
HM0810T	Chipping Hammer	T 170
HM0870C	Chipping Hammer	T 170
HM0871C	Chipping Hammer	T 170
HM1101C	Demolition Hammer	T 170
HM1111C	Demolition Hammer	T 171
HM1201	Demolition Hammer	T 171
HM1203C	Demolition Hammer	T 171
HM1213C	Demolition Hammer	T 171
HM1214C	Demolition Hammer	T 172
HM1304	Demolition Hammer	T 172
HM1306	Demolition Hammer	T 172
HM1307C	Demolition Hammer	T 172
HM1317C	Demolition Hammer	T 173
HM1801	Breaker	T 173
HM1802	Breaker	T 174
HM1812	Breaker	T 173
HP001G	Percussion Driver Drill	T 023
HP0300	Impact Drill	T 151
HP1230	Impact Drill	T 151
HP1630K	Impact Drill	T 152
HP1631K	Impact Drill	T 152
HP1640K	Impact Drill	T 153
HP1640KX2	Impact Drill	T 153
HP1640KX3	Impact Drill	T 153
HP2000	Impact Drill	T 155
HP2010N	Impact Drill	T 155
HP2050	Impact Drill	T 155
HP2070	Impact Drill	T 155
HP331D	(DC) Percussion Driver Drill	T 110
HP332D	(DC) Percussion Driver Drill	T 109
HP333D	(DC) Percussion Driver Drill	T 109
HP347D	(DC) Percussion Driver Drill	T 126
HP457D	(DC) Percussion Driver Drill	T 124
HR166D	Rotary Hammer	T 108
HR1841F	Rotary Hammer	T 161
HR002G	(DC) Combination Hammer	T 027
HR003G	(DC) Combination Hammer	T 027
HR2010	Rotary Hammer	T 161
HR2020	Rotary Hammer	T 161
HR2432	Combination Hammer	T 162
HR2475	Combination Hammer	T 162
HR2600	Rotary Hammer	T 162
HR2611F	Combination Hammer	T 163
HR2611FT	Combination Hammer	T 163
HR2630	Combination Hammer	T 162
HR2630T	Combination Hammer	T 163
HR2631F	Combination Hammer	T 163
HR2631FT	Combination Hammer	T 164
HR2661	Combination Hammer	T 164
HR2800	Rotary Hammer	T 165
HR2810	Combination Hammer	T 165
HR3200C	Combination Hammer	T 165
HR3210C	Combination Hammer	T 165
HR3530	Rotary Hammer	T 166
HR3540C	Combination Hammer	T 166
HR3541FC	Combination Hammer	T 166
HR4001C	Rotary Hammer	T 167
HR4003C	Rotary Hammer	T 167
HR4013C	Rotary Hammer	T 167
HR4030C	Rotary Hammer	T 168
HR4500C	Rotary Hammer	T 168
HR4501C	Rotary Hammer	T 168
HR4511C	Rotary Hammer	T 168
HR5202C	Rotary Hammer	T 169
HR5211C	Rotary Hammer	T 169
HR5212C	Rotary Hammer	T 169
HS001G	(DC) Circular Saw	T 031
HS301D	(DC) Circular Saw	T 114
HS0600	Circular Saw	T 220
HS7010	Circular Saw	T 219
HW131	High Pressure Cleaner	T 256
HW132	High Pressure Cleaner	T 256
HW151	High Pressure Cleaner	T 256
HW1200	High Pressure Cleaner	T 255
HW1300	High Pressure Cleaner	T 255
J		
JN1601	Nibbler	T 184
JN3201	Nibbler	T 184
JR001G	(DC) Recipro Saw	T 031
JR105D	(DC) Recipro Saw	T 115
JR1000FT	Recipro Saw	T 214
JR3050T	Recipro Saw	T 214
JR3051T	Recipro Saw	T 214
JR3060T	Recipro Saw	T 215
JR3070CT	Recipro Saw	T 215
JS1601	Straight Metal Shear	T 183
JS1602	Metal Shear	T 183
JS3201	Metal Shear	T 183
JV101D	(DC) Jig Saw	T 115
JV102D	(DC) Jig Saw	T 115
JV103D	(DC) Jig Saw	T 115
JV183D	(DC) Jig Saw	T 125
K		
KP0800XK	Power Planer	T 228
KP0810K	Power Planer	T 228
L		
LB1200F	Band saw	T 225
LC1230	Metal Cutting Saw	T 181
LD030P	Laser Distance Measure	T 263
LD050P	Laser Distance Measure	T 262
LD080PI	Laser Distance Measure	T 262
LF1000	Flip Over saw	T 218
LH1040	Table Top Miter Saw	T 217
LH1201FL	Table Top Miter Saw	T 217
LS0714	Slide Compound Saw	T 216
LS0815FL	Slide Compound Miter Saw	T 216
LS1018LN	Slide Compound Saw	T 216
LS1019L	Slide Compound Saw	T 215
LS1040	Slide Compound Saw	T 216
LS1219L	Slide Compound Saw	T 215
LS1440	Miter Saw	T 217
LW1400	Portable Cut-off	T 182
LW1401	Portable Cut-off	T 182
M		
ML103	(DC) LED Flashlight	T 134
ML106	(DC) LED Flashlight	T 134
MLS100N	Miter Saw	T 217
MLT100N	Table Saw	T 218
MP100D	(DC) Inflator	T 135
MR052	(DC) Radio	T 137
N		
N1900BK	Power Planer	T 227
N1923BK	Power Planer	T 227
N5900B	Circular Saw	T 220
N9500N	Angle Grinder	T 190
NHP1300S	Impact Drill	T 151
NHP1320S	Impact Drill	T 151
P		
PO6000C	Random Orbit Polisher	T 206
PC1100	Concrete Planer	T 203
PC5000C	Concrete Planer	T 203
PC5001C	Concrete Planer	T 203
PDC100	(DC) Backpack Powerpack	T 035
PF0410	Submersible Pump	T 298
PJ7000	Plate Joiner	T 229
PLM4120N	Petrol Lawn Mower	T 297
PLM4620N2	Petrol Lawn Mower	T 297
PLM4630N2	Petrol Lawn Mower	T 298
PLM4621N2	Petrol Lawn Mower	T 297
PLM4622N	Petrol Lawn Mower	T 298
PLM5113N2	Petrol Lawn Mower	T 298
PM7650H	Backpack Petrol Mist Blower	T 293
PT354D	(DC) Pin Nailer	T 116
PV7000C	Polisher	T 206
PW5001C	Stone Polisher	T 207
R		
RBC411U	Petrol Brush Cutter	T 286
RP0900	Router (Plunge Type)	T 230
RP1800	Router (Plunge Type)	T 231
RP2300FC	Router (Plunge Type)	T 231
RST250	Petrol String Trimmer	T 286
RT0700C	Trimmer	T 229
S		
SA7000C	Angle Sander	T 207
SA7021	Angle Sander	T 207
SC103D	(DC) Threaded Rod Cutter	T 113
SD100D	(DC) Drywall Cutter	T 114
SG150	Wall Chaser	T 179
SG1250	Wall Chaser	T 179
SG1251J	Wall Chaser	T 179

SJ401	Scroll Saw	T 224
SK102Z	(DC) Cross Line Laser Level	T 264
SK103PZ	(DC) 4 point Cross Line Laser Level	T 264
SK105GD	(DC) Cross Line Laser Level	T 118/260
SK105D	(DC) Cross Line Laser Level	T 118/260
SK106GD	(DC) 4 point Cross Line Laser Level	T 118/260
SK106D	(DC) 4 point Cross Line Laser Level	T 118/260
SKR301	(DC) Rotary Laser Level	T 263
SK312GD	(DC) Green Multi line Laser	T 119/261
SP6000	(DC) Plunge Cut Circular Saw	T 221
ST113D	(DC) Stapler	T 116
T		
TB131	Drill Press	T 149
TD001G	(DC) Impact Driver	T 024
TD0101	Impact Driver	T 142
TD022D	(DC) Impact Driver	T 122
TD110D	(DC) Impact Driver	T 110
TD111D	(DC) Impact Driver	T 110
TL064D	(DC) Angle Impact Driver	T 112
TL065D	(DC) Angle Impact Wrench	T 112
TM30D	(DC) Multi Tool	T 113/186
TM3010CK	Multi Tool	T 186
TW001G	(DC) Impact Wrench	T 024
TW005G	(DC) Impact Wrench	T 025
TW0350	Impact Wrench	T 143
TW1000	Impact Wrench	T 143
TW161D	Impact Wrench	T 111
U		
UB0801V	Blower	T 291
UB100D	(DC) Blower	T 120
UB1102	Blower	T 291
UB1103	Blower	T 291
UC4041A	Chain Saw	T 279
UC4551A	Chain Saw	T 279
UH5261	Hedge Trimmer	T 281
UH6570	Hedge Trimmer	T 281
UH7580	Hedge Trimmer	T 281
UM600D	(DC) Grass Shear	T 119/288
UR100D	(DC) String Trimmer	T 119/285
UR101C	(DC) Battery Powered Grass Trimmer	T 038/283
UR201C	(DC) Battery Powered Grass Trimmer	T 038/283
UR3000	String Trimmer	T 286
UT1305	Power Mixer	T 150
UT1400	Power Mixer	T 150
UT2204	Power Mixer	T 150
V		
VC2000L	Vacuum Cleaner	T 235
VC3210LX1	Vacuum Cleaner	T 234
VC3211HX1	Vacuum Cleaner	T 234
W		
WR100D	(DC) Ratchet Wrench	T 111
WUT02	Auto-Start Wireless Adapter	T 236

DF001G

40V MAX XGT - Li-ion Cordless Driver Drill (13mm)



Pg. T023 **40V^{max} XGT MOTOR BL AFT XPT**

HP001G

40V MAX XGT - Li-ion Cordless Percussion Driver Drill (13mm)



Pg. T023 **40V^{max} XGT MOTOR BL AFT XPT**

TD001G

40V MAX XGT - Li-ion Cordless Impact Driver (6.35mm)



Pg. T024 **40V^{max} XGT MOTOR BL XPT**

TW001G / TW005G

40V MAX XGT - Li-ion Cordless Impact Wrench (3/4" / 1/2")



Pg. T024-025 **40V^{max} XGT MOTOR BL XPT**

HR002G

40V MAX XGT - Li-ion Cordless Combination Hammer (SDS-PLUS) (28mm)



Pg. T027 **40V^{max} XGT MOTOR BL AFT AWS AVT SOFT XPT**

HR003G

40V MAX XGT - Li-ion Cordless Combination Hammer (SDS-PLUS) (28mm)



Pg. T027 **40V^{max} XGT MOTOR BL AVT XPT**

GA004G / GA005G

40V MAX XGT - Li-ion Cordless Angle Grinders (115 / 125mm)



Pg. T029 **40V^{max} XGT MOTOR BL AFT XPT**

GA012G / GA013G

40V MAX XGT - Li-ion Cordless Angle Grinders (115 / 125mm)



Pg. T029 **40V^{max} XGT MOTOR BL AFT XPT**

GA022G / GA023G

40V MAX XGT - Li-ion Cordless Angle Grinders (115 / 125mm)



Pg. T030 **40V^{max} XGT MOTOR BL AFT XPT AWS**

GA028G / GA029G

40V MAX XGT - Li-ion Cordless Angle Grinders (115 / 125mm)



Pg. T030 **40V^{max} XGT MOTOR BL AFT XPT AWS**

HS004G

40V MAX XGT - Li-ion Cordless Circular Saw (185 / 190mm)



Pg. T031 **40V^{max} XGT MOTOR BL ADT XPT AWS**

JR001G

40V MAX XGT - Li-ion Cordless Reciprocating Saw



Pg. T031 **40V^{max} XGT MOTOR BL XPT**

CF001G

40V MAX XGT - Li-ion Cordless Fan



Pg. T031 **40V^{max} XGT MOTOR**

UR101C / UR201C

18V + 18V LXT - Li-ion Cordless Battery Powered Grass Trimmer (430mm - Trimmer Head)



Pg. T038 **18V + 18V LXT BL XPT ADT AFT**

DUR369A / DUR369N

18V + 18V LXT - Li-ion Cordless String Trimmer (430mm - Trimmer Head)



Pg. T039 **18V + 18V LXT BL XPT ADT AFT**

DUP362

18V + 18V LXT - Li-ion Cordless Pruning Shears



Pg. T040 **18V + 18V LXT BL XPT**

DUB363

18V + 18V LXT - Li-ion Cordless Blower + Vacuum



Pg. T040 **18V + 18V LXT BL XPT**

DLM533 / DLM532 / DLM531

18V + 18V LXT - Li-ion Cordless Lawn Mower (adapted to four 18V LXT batteries) (530mm)



Pg. T042-043 **18V + 18V LXT BL XPT**

DLM382
 18V + 18V LXT - Li-ion Cordless Lawn Mower (380mm)



Pg. T043  **XPT**

DCE090
 18V + 18V LXT - Li-ion Cordless Power Cutter (230mm)



Pg. T044  **BL XPT AFT** 

DHR400N
 18V + 18V LXT - Li-ion Cordless Rotary Hammer (SDS-MAX) (40mm)



Pg. T044  **AWS BL XPT AFT SDS-MAX AFT**

DDG460
 18V + 18V LXT - Li-ion Cordless Earth Auger



Pg. T047  **BL XPT ADT**

DHS900
 LXT - Li-ion Cordless Circular Saw (235mm)



Pg. T051  **BL ADT AWS XPT** 

DVC560
 18V + 18V LXT - Li-ion Cordless Upright Vacuum Cleaner



Pg. T053  **BL HEPA MOTOR**

DVC665
 18V + 18V LXT - Li-ion Cordless Backpack Dust Extractor



Pg. T054  **BL AWS HEPA**

DVC660
 18V + 18V LXT - Li-ion Backpack Cordless Vacuum Cleaner



Pg. T055  **BL HEPA**

DVC154L
 18V + 18V LXT - Li-ion Cordless Dust Extractor



Pg. T056  **AWS BL XPT HEPA Filter**

DVC150L
 18V + 18V LXT - Li-ion Cordless Vacuum Cleaner



Pg. T057  **HYBRID**

DHK180
 18V LXT - Li-ion Cordless Power Scraper (SDS-PLUS)



Pg. T061  **BL XPT**

DTD171
 18V LX/T - Li-ion Cordless Impact Driver (6.35mm)



Pg. T066  **BL XPT**

DTW701
 18V LXT - Li-ion Cordless Impact Wrench (1/2")



Pg. T068  **BL XPT**

DTW300
 18V LXT - Li-ion Cordless Impact Wrench (1/2")



Pg. T069  **BL XPT**

DRV150
 18V LXT - Li-ion Cordless Riveter



Pg. T072  **BL XPT**

DSC121
 18V LXT - Li-ion Cordless Threaded Rod Cutter (8 - 12 mm)



Pg. T073  **BL XPT**

DSC163
 18V LXT - Li-ion Cordless Steel Rod Cutter (16mm)



Pg. T074  **BL**

DPP200
 Hole Puncher



Pg. T075 

DPB183

18V LXT - Li-ion Cordless Band Saw



Pg. T078  **BL** 

DJS101

18V LXT - Li-ion Cordless Metal Shear (1mm)



Pg. T080 

DGA519 / DGA469

18V LXT - Li-ion Cordless X-Lock Angle Grinders (115mm / 125mm)



Pg. T082  **BL**  **X-LOCK** 

DBS180

18V LXT - Li-ion Cordless Belt Sander



Pg. T085  **BL** 

DKP181

18V LXT - Li-ion Cordless Planer (82mm)



Pg. T090  **BL** 

DCO181

18V LXT - Li-ion Cordless Cut-Out Tool



Pg. T090  **BL** 

DFN350

18V LXT - Li-ion Cordless Brad Nailer



Pg. T093  **BL** 

DCL184

18V LXT - Li-ion Cordless Cleaner + Blower



Pg. T097 

DCL281

18V LXT - Li-ion Cordless Cleaner



Pg. T098  **BL** 

DUN500W

18V LXT - Li-ion Cordless Pole Hedge Trimmer (500mm)



Pg. T100  **BL** 

DUH754S

18V LXT - Li-ion Cordless Hedge Trimmer (750mm)



Pg. T101  **BL** 

DUR190

18V LXT - Li-ion Cordless Grass Trimmer (300mm- Trimmer Head)



Pg. T102  **BL** 

DUB184

18V LXT - Li-ion Cordless Blower



Pg. T103  **BL** 

DUB185

18V LXT - Li-ion Cordless Blower



Pg. T103 

DF333D / HP333D

12V MAX CXT - Li-ion Cordless Driver Drill / 12V MAX CXT - Li-ion Percussion Driver Drill



Pg. T108 / T109  **CXT** 

WR100D

12V MAX CXT - Li-ion Cordless Ratchet Wrench (3/8" / 1/4")



Pg. T111  **CXT** 

SC103D

12V MAX CXT - Li-ion Cordless Threaded Rod Cutter



Pg. T113  **CXT** 

UB100D

12V MAX CXT - Li-ion Cordless Blower



Pg. T120  **CXT** 

CL108FD
12V MAX CXT - Li-ion Cordless Cleaner



Pg. T120 

DCB200 / CB100D
18V LXT / 12V MAX - Li-ion Cordless Heated Blanket



Pg. T130  

DML810
18V LXT - Li-ion Cordless + Corded Area Worklight (Adapted upto two 18V LXT batteries)



Pg. T132  

DML814
18V LXT - Li-ion Cordless Area Worklight



Pg. T132 

DML809
18V LXT - Li-ion Cordless + Corded Area Worklight (Adapted upto two 18V LXT batteries)



Pg. T132  

DML811
18V LXT - Li-ion Cordless + Corded Area Worklight



Pg. T133  

DML812 / DML815
18V LXT - Li-ion Cordless Flashlight



Pg. T133 

DMP180
18V LXT - Li-ion Cordless Inflator



Pg. T135 

DMR203
18V LXT / 12V MAX - Li-ion Cordless Bluetooth Speaker



Pg. T136  

DP2010
High Speed Drill (6.5mm)



Pg. T145

UT1305
Power Mixer (165mm)



Pg. T150

GA4050 | GA4550/GA4550R | GA5050/GA5050R
Angle Grinders (100mm | 115mm | 125mm)



Pg. T195

9237CB
Polisher (180mm)



Pg. T206

JR3051T
Recipro Saw (130mm)



Pg. T224

VC2000L
Vacuum Cleaner (Wet & Dry)



Pg. T235

WUT02
Auto-Start Wireless Universal Adapter (Adapted to AC Vacuum Cleaners)



Pg. T235

AF506
Pneumatic Brad Nailer



Pg. T267

AN613
Pneumatic Coil Nailer



Pg. T267

Cordless Tools

XGT / LXT / CXT / G-Series / Comfort@Work

**MAKITA'S TOOL RANGE IS STRONGER THAN EVER
TOOLS IN ALL SIZES FOR EVERY APPLICATION**



XGT

**The cordless answer
to high demands**

With the new 40V Max XGT series, Makita expands its range of high-quality cordless tools and continues to penetrate into areas that were previously reserved for AC-powered machines.



LXT

**World's largest
18V Li-ion system**

Tool users who unplug the cord with Makita 18V LXT experience new levels of convenience, efficiency and productivity.



CXT

**More comfort
and capacity**

CXT 12V Max, Compact Extreme System, gives users a more compact solution with more comfort and more capacity.

Since the Launch of 18V LXT in 2005, Makita has been leading the way in Cordless Tool innovation and technology. 18V LXT provides consumers with not only the largest range on one battery, it also provides consumers with the most reliable and efficient tools available. Our vision as a Company is to provide consumers with a battery solution for all applications across Building Construction, Industrial, Outdoor Power Equipment and Commercial Cleaning Channels In keeping with our vision. Makita is ready to lead the way once again, we are excited to announcement the launch of our new XGT 40V battery system that will coexist with LXT, CXT and continue towards our vision of a battery solution for all applications!



HIGH PERFORMANCE WITH BRUSHLESS DC MOTOR

BL MOTOR

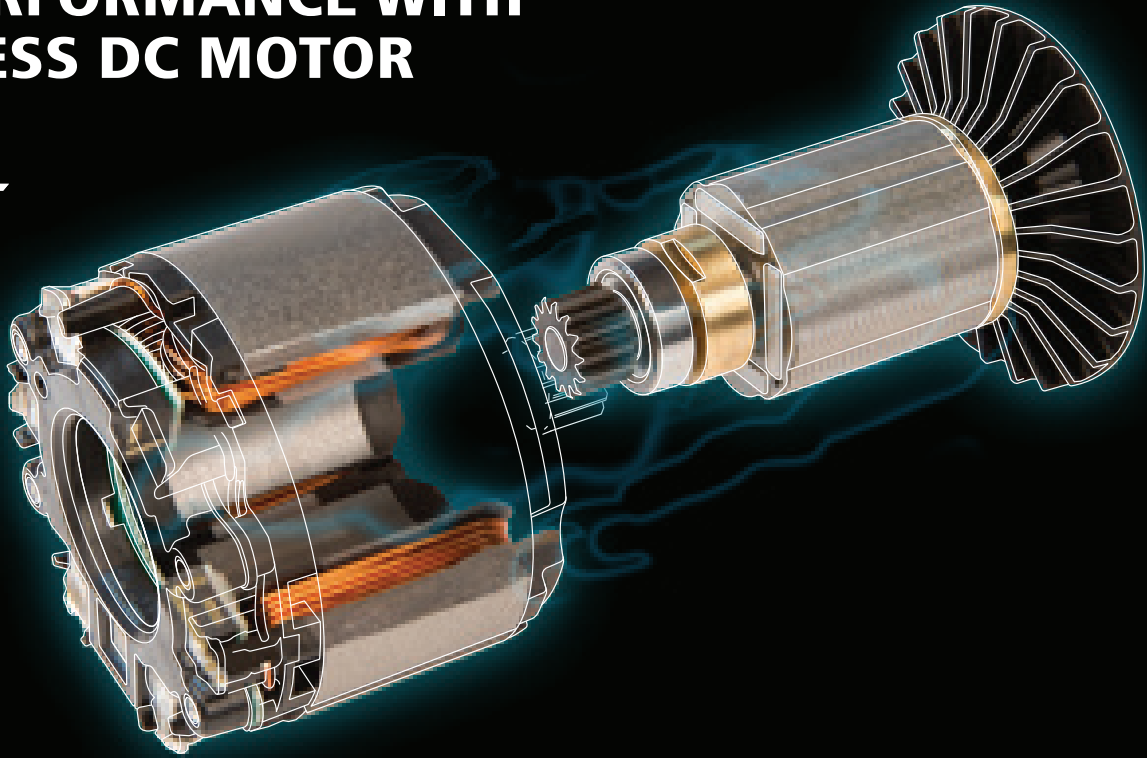

UP TO 50% LONGER MOTOR LIFE

Makita-built Brushless Motor eliminates carbon brushes, enabling the motor to run cooler and more efficiently for longer life.

(Compared to Cordless Motors with Brushes)

VARIOUS TYPES OF BRUSHLESS MOTORS



OUTER ROTOR

A direct-drive system that delivers the highest operating efficiency for more power, more speed and longer run time. The outer rotor brushless motor is inside select chain saws and string trimmers

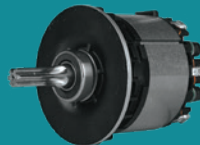
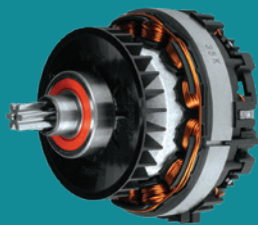

108mm, 80mm, 52mm, 44mm & 38mm

Built for higher power and efficiency in a compact size with all-metal gear construction for extended durability. The 52mm brushless motor can be found in select blowers, trimmers, and more.



Dust extractor starts automatically when the tool starts.
Also dust extractor stops on its own when the tool is in rest

Auto-start wireless system

The AWS dust extractor runs only while the AWS power tool is in use which benefits:-

- a) Extends battery run time of the dust extractor increasing productivity on a single charge.
- b) Reducing continuous noise at the work site due to dust extractor will switch off automatically if the tool is not in use
- c) Reduced time wasted on manually powering the dust extractor on and off.



Using our cordless dust extractor with a cordless Li-ion tool means freedom of movement, reduced safety hazards and no plug-in or power issue

WATCH VIDEO



HOW IT WORKS



1 Set the stand-by switch on the dust extractor to "AUTO" (FOR DVC864L / DVC154L) / "Slide On" (FOR DVC265/DVC665)



2 Press the wireless activation button on the dust extractor for 3 seconds until the wireless activation lamp blinks in GREEN



3 Then press the wireless activation button on the tool until the wireless activation lamp blinks in GREEN

Also you can disengage the paired dust extractor and tools by pressing the wireless activation button on the dust extractor for 6 seconds which turns wireless activation lamp to blinks in green and then become in red. After that, press the wireless activation button on the tool in the same way

Also note that the paired wireless unit can be used with any AWS equipped machines and need not to pair again until if it is disengaged.

Multiple Connections

Can connect upto 10 AWS tools at a time with single dust extractor, just reconnect the dust hose when switching between power tools, this will reduce time wasted on manually powering multiple tools on and off

Wireless unit (Bluetooth chip) Part#: 198900-7



Wireless unit (bluetooth chip) utilizes Bluetooth technology for wireless power-on/off communication.

Please make sure the wireless unit (bluetooth chip) is inserted in the wireless unit slot on the Tool/Dust extractor before pairing.

Auto-Start Wireless Adapter - WUT02 Part#: 199838-9



WUT02 adapts to AC Dust Extractors VC3210LX1 / VC3211HX1 and enables wireless On/Off communication with Makita AWS tools (BLUETOOTH CHIP SOLD SEPARATELY)









CORDLESS















Lithium-ion Battery / Charger Reference Chart

40V MAX XGT battery / charger

XGT to LXT Adapter







FIXING / FASTENING	110 - 120 (2pin type) Part no 220 - 240 (2pin type) Part no 220 - 240 (3pin type) Part no		DC40RA (XGT - FAST CHARGER) 191E05-2 191E13-3 191E14-1		18V LXT Lithium-ion batteries  ADP10 (ADAPTER) 191C11-5 (Used with XGT charger to charge LXT batteries)
	40V MAX XGT Lithium-ion 				
DRILLING / IMPACT DRILLING	4.0Ah 		45 min. Fast Charging		6.0 Ah  BL1860B 5.0 Ah  BL1850B
CONCRETE DRILLING / DEMOLITION	BATTERY ID: BL4040 PART NO: 191B26-6 PACKAGE: CARTON FUEL GAUGE: ✓		25 min. Fast Charging		3.0 Ah  BL1830B
CUTTING [CONCRETE/ MASONRY/ METAL]					

18V / 14.4V Li-ion (LXT) battery / charger

			SINGLE PORT CHARGER DC18RC (LXT FAST CHARGER)	TWO PORT CHARGER DC18RD (LXT FAST CHARGER)	TWO PORT CHARGER DC18RE (LXT + CXT FAST CHARGER)	FOUR PORT CHARGER DC18SF (LXT STANDARD CHARGER)	AUTOMOTIVE CHARGER DC18SE (LXT STANDARD CHARGER)	
MULTI TOOL	110 - 120 (2pin type) Part no		195582-6					
	110 - 120 (3pin type) Part no			196929-7*				
	220 - 240 (2pin type) Part no		195584-2	196933-6	198575-2		194621-9 <small>(compatible with 12V/ 24V DC cigarette lighter socket)</small>	
	220 - 240 (3pin type) Part no		197378-1	196940-9	198447-1	196427-1		
GRINDING	18V LXT Lithium-ion 6.0Ah 							
	14.4V LXT Lithium-ion -		55 min. Fast Charging		55 min. Fast Charging		55 min. Fast Charging	
SAWING	BATTERY ID: BL1860B PART NO: 197422-4 PACKAGE: Single FUEL GAUGE: ✓		130min. 1 to 2 batteries 260min. 3 to 4 batteries		130min. 1 to 2 batteries 260min. 3 to 4 batteries		130min.	
	5.0Ah 							
ROUTERING / PLANING	BATTERY ID: BL1850B PART NO: 197280-8 PACKAGE: Single FUEL GAUGE: ✓		45 min. Fast Charging		45 min. Fast Charging		110min. 1 to 2 batteries 220min. 3 to 4 batteries	
	3.0Ah 		45 min. Fast Charging		45 min. Fast Charging		110min. 1 to 2 batteries 220min. 3 to 4 batteries	
CLEANING	BATTERY ID: BL1830B PART NO: 197599-5 PACKAGE: Single FUEL GAUGE: ✓		22 min. Fast Charging		22 min. Fast Charging		60min. 1 to 2 batteries 120min. 3 to 4 batteries	
	3.0Ah 		22 min. Fast Charging		22 min. Fast Charging		60min. 1 to 2 batteries 120min. 3 to 4 batteries	
HEAT GUN / LASERS	BATTERY ID: BL1815N PART NO: 632A54-1 PACKAGE: Bulk FUEL GAUGE: x		15 min. Fast Charging		15 min. Fast Charging		30min. 1 to 2 batteries 60min. 3 to 4 batteries	
	1.5Ah 		15 min. Fast Charging		15 min. Fast Charging		30min. 1 to 2 batteries 60min. 3 to 4 batteries	
PNEUMATIC TOOLS	BATTERY ID: BL1415NA PART NO: 196280-5 PACKAGE: Single FUEL GAUGE: ✓		15 min. Fast Charging		15 min. Fast Charging		30min. 1 to 2 batteries 60min. 3 to 4 batteries	
	1.5Ah 		15 min. Fast Charging		15 min. Fast Charging		30min. 1 to 2 batteries 60min. 3 to 4 batteries	
GARDEN TOOLS	BATTERY ID: BL1815 PART NO: 195445-6 PACKAGE: Single FUEL GAUGE: x		15 min. Fast Charging		15 min. Fast Charging		30min. 1 to 2 batteries 60min. 3 to 4 batteries	
	1.3Ah 		15 min. Fast Charging		15 min. Fast Charging		30min. 1 to 2 batteries 60min. 3 to 4 batteries	
GENERATORS	BATTERY ID: BL1415 PART NO: 638586-0 PACKAGE: Bulk FUEL GAUGE: x		15 min. Fast Charging		15 min. Fast Charging		30min. 1 to 2 batteries 60min. 3 to 4 batteries	
	1.3Ah 		15 min. Fast Charging		15 min. Fast Charging		30min. 1 to 2 batteries 60min. 3 to 4 batteries	

DC18SF: is not compatible is 14.4V Li-ion Battery 196929-7* - in future it will be available in 2 Pin only

12V MAX / 10.8V Li-ion (CXT) battery / charger (Slide type)

		SINGLE PORT CHARGER DC10SB (CXT - FAST CHARGER)	TWO PORT CHARGER DC18RE (LXT + CXT FAST CHARGER)
110 - 120 (2pin type) Part no		197435-5	198443-9
220 - 240 (2pin type) Part no		198576-0	198575-2
220 - 240 (3pin type) Part no		198433-2	198447-1
12V MAX / 10.8V CXT Lithium-ion			
4.0Ah 		60 min. Fast Charging	60 min. Fast Charging
BATTERY ID	BL1041B		
PART NO	197406-2		
PACKAGE	CARTON		
FUEL GAUGE	✓		
2.0Ah 		30 min. Fast Charging	30 min. Fast Charging
BATTERY ID	BL1021B		
PART NO	197396-9		
PACKAGE	CARTON		
FUEL GAUGE	✓		

- CORDLESS
- FIXING / FASTENING
- DRILLING / IMPACT DRILLING
- CONCRETE DRILLING / DEMOLITION
- CUTTING [CONCRETE/ MASONRY/ METAL]
- MULTI TOOL
- GRINDING
- SANDING / POLISHING
- SAWING
- ROUTERING / PLANING
- CLEANING
- HEAT GUN / LASERS
- PNEUMATIC TOOLS
- GARDEN TOOLS
- GENERATORS

10.8V / 7.2V Li-ion battery / charger (Stick type)





		10.8V - 7.2V CHARGER DC10WA	7.2V CHARGER DC70SA	
220 - 240 (2pin type) Part no		630584-0	194320-3 / 194588-1	
220 - 240 (3pin type) Part no		630585-0		
10.8V Lithium-ion (Stick battery)				
1.3Ah  BL1013 Part no: 196066-7			50 min.	
7.2V Lithium-ion (Stick battery)				
1.5Ah  B7015 Part no: 198000-3				35 min.
1.0Ah  B7010 Part no: 194355-4				30 min.

- CORDLESS
- FIXING / FASTENING
- DRILLING / IMPACT DRILLING
- CONCRETE DRILLING / DEMOLITION
- CUTTING [CONCRETE/ MASONRY/ METAL]
- MULTI TOOL
- GRINDING
- SANDING / POLISHING
- SAWING
- ROUTERING / PLANING
- CLEANING
- HEAT GUN / LASERS
- PNEUMATIC TOOLS
- GARDEN TOOLS
- GENERATORS



3.6V Li-ion (in-built battery and Adapter)

		AC ADAPTER WITH MICRO USB PORT
	2pin 3pin	ADP07 198363-7 198369-5
3.6V Lithium-ion (In-built Battery)		
1.5Ah Part no: 620693-3 (comes along with controller)	3-5 hrs.	

36V Li-ion Battery and Charger

		DC36RA	DC3600
110 - 120 (2pin type) Part no		194869-3	197727-2
220 - 240 (3pin type) Part no		194864-3	-
36V LXT Lithium-ion			
 2.6Ah BL3626 Part no: 194873-2	22 min.		-
 12.0Ah BL36120A Part no: BL36120A	-		180 min.

G-series Lithium-ion (18V - 14.4V Li-ion)

		18V - 14.4V CHARGER
		DC18WA
127V (2pin type) Part no		197812-1
220 - 240 (2pin type) Part no		195423-6
220 - 240 (3pin type) Part no		197130-7
18V G SERIES Lithium-ion	14.4V G SERIES Lithium-ion	
 1.5Ah BL1815G Part no: 198186-3	 1.5Ah BL1415G Part no: 198192-8	70 min.

Power Source Kit

A combination of Makita 18V Li-ion Batteries and Charger in a Makpac connector case with moulded inlay. Makita owns the world's largest cordless tool line-up in 18V Li-ion tools and offer them in different variants i.e. 6.0Ah, 5.0Ah, 3.0Ah. Tools are also offered without battery & charger. Now pick up the Makita Power source kit, then purchase the 18V "bare tools" and you get the job done. It's an ideal way to start building a Makita cordless tool line-up. Users who preowned "Tool only version" (i.e. Tool without battery and charger) can benefit with this power source kits.

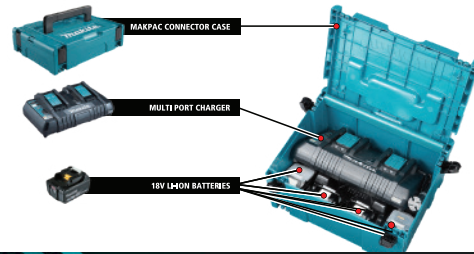

XGT (With 40V MAX - 4.0Ah Battery x 2pcs)

Part no	SET CONTENTS										
	BATTERY					CHARGER					MAKPAC CASE
	MODEL	VOLTS	AMPERE	FUEL GAUGE	QTY	MODEL	VOLTS	PORT	PIN	QTY	
191K03-2	BL4040	40 MAX	4.0Ah	✓	2pcs	DC40RA	40 MAX L-ION	1	3	1pc	Type 1

LXT (With 6.0Ah Battery x 2pcs)

Part no	SET CONTENTS										
	BATTERY					CHARGER					MAKPAC CASE
	MODEL	VOLTS	AMPERE	FUEL GAUGE	QTY	MODEL	VOLTS	PORT	PIN	QTY	
198082-5	BL1860B	18V Li-ion	6.0Ah	✓	2pcs	DC18RD	18V-14.4V Li-ion	2	3	1pc	Type 3

LXT (With 6.0Ah Battery x 1pc)

Part no	SET CONTENTS										
	BATTERY					CHARGER					MAKPAC CASE
	MODEL	VOLTS	AMPERE	FUEL GAUGE	QTY	MODEL	VOLTS	PORT	PIN	QTY	
198108-3	BL1860B	18V Li-ion	6.0Ah	✓	1pc	DC18RC	18V-14.4V Li-ion	1	3	1pc	Type 1

LXT (With 5.0Ah Battery x 4pcs)

Part no	SET CONTENTS										
	BATTERY					CHARGER					MAKPAC CASE
	MODEL	VOLTS	AMPERE	FUEL GAUGE	QTY	MODEL	VOLTS	PORT	PIN	QTY	
198568-9	BL1850B	18V Li-ion	5.0Ah	✓	4pcs	DC18RD	18V-14.4V Li-ion	2	3	1pc	Type 3
197626-8	BL1850B	18V Li-ion	5.0Ah	✓	4pcs	DC18RD	18V-14.4V Li-ion	2	2	1pc	Type 3

LXT (With 5.0Ah Battery x 2pcs)

Part no	SET CONTENTS										
	BATTERY					CHARGER					MAKPAC CASE
	MODEL	VOLTS	AMPERE	FUEL GAUGE	QTY	MODEL	VOLTS	PORT	PIN	QTY	
198567-1	BL1850B	18V Li-ion	5.0Ah	✓	2pcs	DC18RD	18V-14.4V Li-ion	2	3	1pc	Type 3
197629-2	BL1850B	18V Li-ion	5.0Ah	✓	2pcs	DC18RD	18V-14.4V Li-ion	2	2	1pc	Type 3

LXT (With 3.0Ah Battery x 4pcs)

Part no	SET CONTENTS										
	BATTERY					CHARGER					MAKPAC CASE
	MODEL	VOLTS	AMPERE	FUEL GAUGE	QTY	MODEL	VOLTS	PORT	PIN	QTY	
197972-9	BL1830B	18V Li-ion	3.0Ah	✓	4pcs	DC18RD	18V-14.4V Li-ion	2	3	1pc	Type 3

LXT (With 3.0Ah Battery x 1pc)

Part no	SET CONTENTS										
	BATTERY					CHARGER					MAKPAC CASE
	MODEL	VOLTS	AMPERE	FUEL GAUGE	QTY	MODEL	VOLTS	PORT	PIN	QTY	
191A26-0	BL1830B	18V Li-ion	3.0Ah	✓	1pc	DC18RC	18V-14.4V Li-ion	1	3	1pc	Type 1

LXT/CXT (With 4.0Ah CXT Battery x 1pc and 5.0Ah LXT Battery x 1pc)

Part no	SET CONTENTS										
	BATTERY					CHARGER					MAKPAC CASE
	MODEL	VOLTS	AMPERE	FUEL GAUGE	QTY	MODEL	VOLTS	PORT	PIN	QTY	
199360-6	BL1041B	12VMAX Li-ion	4.0Ah	✓	1pc	DC18RE	LXT + CXT	MULTI	3	1pc	Type 3
	BL1850B	18V Li-ion	5.0Ah	✓	1pc						
199359-1	BL1041B	12VMAX Li-ion	4.0Ah	✓	1pc	DC18RE	LXT + CXT	MULTI	2	1pc	Type 3
		BL1850B	18V Li-ion	5.0Ah	✓						

CORDLESS

FIXING / FASTENING

DRILLING / IMPACT DRILLING

CONCRETE DRILLING / DEMOLITION

CUTTING [CONCRETE/ MASONRY/ METAL]

MULTI TOOL

GRINDING

SANDING / POLISHING

SAWING

ROUTERING / PLANING

CLEANING

HEAT GUN / LASERS

PNEUMATIC TOOLS

GARDEN TOOLS

GENERATORS

XGT

40V Li-ION max

Circular Saw
HS004G



Driver Drill
DF001G



Percussion Driver Drill
DF001G



Impact Wrench
TW001G / TW005G



Impact Driver
TD001G



Angle Grinder
GA004G / GA005G
GA012G / GA013G



Angle Grinder (AWS)
GA022G / GA023G
GA028G / GA029G



Reciprocating Saw
JR001G



Combination Hammer
HR002G



Combination Hammer
HR003G



Fan
CF001G



DX12
DX14



DF001G 13mm

Acc Pg. A024-060

40V MAX XGT - Cordless Driver Drill



Efficient, Durable, Compact, Lightweight and Outstanding Performance Driver Drill

- Delivers 140Nm of Max torque achieved with combination of high power brushless motor and innovative XGT battery
- Excellent in Continuous Heavy-Duty Work
- Delivers 35% or more higher speed than LXT model DDF481
- Active Feedback sensing Technology (AFT) turns the motor off if bit rotation is suddenly forced to stop

New electronic clutch settings

A higher range of torque can be covered than with mechanical clutch

- 41-stage setting in gear one
- 21-stage setting in gear two

(XGT: Electronic Clutch
LXT: Mechanical Clutch)

Digital display

Easy jog dial adjustment of fastening torque



Specifications:-



Capacity	Steel: 20 mm Wood (Auger-Bit): 50 mm Wood (Self-Feed Bit): 76 mm Wood (Hole Saw): 152 mm
Chuck Capacity	1.5 - 13 mm
No Load Speed (RPM)	High / Low: 0 - 2,600 / 0 - 650
Max Fastening Torque	Hard / Soft: 140 / 68 N m
Max lock torque	125 Nm
Dimensions (L x W x H)	181x86x282 mm
Net weight	3.0 kg

Standard Equipment: Side Grip.

AVAILABLE VARIANTS

4.0Ah	"Z" VARIANT
DF001G M2 INCLUDES 2 BATTERIES / 1 CHARGER / MAKPAC CONNECTOR CASE	DF001G Z TOOL ONLY (DOES NOT INCLUDE BATTERY / CHARGER / CARRYING CASE)

HP001G 13mm

Acc Pg. A024-060

40V MAX XGT - Cordless Percussion Driver Drill



Efficient, Durable, Compact, Lightweight and Outstanding Performance Percussion Driver Drill

- Delivers 140Nm of Max torque achieved with combination of high power brushless motor and innovative XGT battery
- Excellent in Continuous Heavy-Duty Work
- Delivers 35% or more higher speed than LXT model DHP481
- Active Feedback sensing Technology (AFT) turns the motor off if bit rotation is suddenly forced to stop

New electronic clutch settings

A higher range of torque can be covered than with mechanical clutch

- 41-stage setting in gear one
- 21-stage setting in gear two

(XGT: Electronic Clutch
LXT: Mechanical Clutch)

Digital display

Easy jog dial adjustment of fastening torque



Specifications:-



Capacity	Steel: 20 mm / Wood (Auger-Bit): 50 mm Wood (Self-Feed Bit): 76 mm / (Hole Saw): 152 mm Masonry: 20 mm
Chuck Capacity	1.5 - 13 mm
Impact Speed (IPM)	High / Low: 0 - 39,000 / 0 - 9,750
No Load Speed (RPM)	High / Low: 0 - 2,600 / 0 - 650
Max Fastening Torque	Hard / Soft: 140 / 68 N m
Max lock torque	125 Nm
Dimensions (L x W x H)	182x86x282 mm
Net weight	3.0 kg

Standard Equipment: Side Grip.

AVAILABLE VARIANTS

4.0Ah	"Z" VARIANT
HP001G M2 INCLUDES 2 BATTERIES / 1 CHARGER / MAKPAC CONNECTOR CASE	HP001G Z TOOL ONLY (DOES NOT INCLUDE BATTERY / CHARGER / CARRYING CASE)

CORDLESS

FIXING / FASTENING

DRILLING / IMPACT DRILLING

CONCRETE DRILLING / DEMOLITION

CUTTING [CONCRETE/ MASONRY/ METAL]

MULTI TOOL

GRINDING

SANDING / POLISHING

SAWING

ROUTERING / PLANING

CLEANING

HEAT GUN / LASERS

PNEUMATIC TOOLS

GARDEN TOOLS

GENERATORS

CORDLESS
FIXING / FASTENING
DRILLING / IMPACT DRILLING
CONCRETE DRILLING / DEMOLITION
CUTTING (CONCRETE/ MASONRY/ METAL)
MULTI TOOL
GRINDING
SANDING / POLISHING
SAWING
ROUTERING / PLANING
CLEANING
HEAT GUN / LASERS
PNEUMATIC TOOLS
GARDEN TOOLS
GENERATORS

TD001G
Acc Pg. A024-031

40V MAX XGT - Cordless Impact Driver



Efficient, Durable, Compact, Lightweight and Outstanding High Power 220 N.m, excellent in continuous heavy-duty work

- 10 models for or multiple applications
Wood/Bolt (1, 2, 3) /T-Mode (1, 2) /Max / Hard /Medium / Soft mode
- New one-touch bit installation
- Constant speed control maintains fastening torque by preventing the rotation speed reduction caused by decreased battery capacity



One-touch 4-speed selector
Provides precise fastening control for a wide range of applications

Quick-change memory mode
allows operator to rapidly change between two registered setting



Specifications:-

Capacity	Machine Screw: M4 - M8 (5/32" - 5/16") Standard Bolt: M5 - M16 (3/16" - 5/8") High Strength Bolt: M5 - M14 (3/16" - 9/16") Coarse thread : 22 - 125 mm (7/8" - 4-7/8")
Hex Shank	6.35 mm (1/4")
No Load Speed (RPM)	Max / H / M / S: 0 - 3,700 / 3,200 / 2,100 / 1,100
Impacts Per Minute (IPM)	Max / H / M / S: 0 - 4,400 / 3,600 / 2,600 / 1,100
Max Fastening Torque	220 Nm
Fastening Torque	Hard / Med / Soft: 170 / 50 / 20 N m
Sound Pressure Level	96 dB(A)
Sound Power Level	107 dB(A)
Dimensions (L x W x H)	120x86x250 mm
Net weight	2.0 kg

AVAILABLE VARIANTS

4.0Ah	"Z" VARIANT
TD001G M2 <small>INCLUDES 2 BATTERIES / 1 CHARGER / MAKPAC CONNECTOR CASE</small>	TD001G Z <small>TOOL ONLY (DOES NOT INCLUDE BATTERY / CHARGER / CARRYING CASE)</small>

TW001G 3/4"
Acc Pg. A032-036

40V MAX XGT - Cordless Impact Wrench



Nut buster Impact Wrench with over 2030N.m Torque

- Reverse Rotation Auto Stop Mode stops after the bolt/nut loosened enough
- Single speed mode for reduced trigger-pulling force

Full Speed Mode
Switches between variable and full speed by pressing the button. Reaches full speed with fewer pull trigger to minimize user's fatigue in continuous work

Electronic -4stage impact power selection
Enables user to control the power and speed depending on the applications



Compact overall length
For easy handling and control



217 mm

18V LXT (DTW1001 - 229mm)

Specifications:-

Fastening Capacities	Standard Bolt: M12 - M36 High Strength Bolt: M10 - M27
Square Drive	19 mm (3/4")
No Load Speed (RPM)	Max /H/M/S: 0 - 1,800 / 0 - 1,400 / 0 - 1,150 / 0 - 950
Impacts Per Minute (IPM)	Max /H/M/S: 0 - 2,500 / 0 - 2,400 / 0 - 2,200 / 0 - 1,900
Max Fastening Torque	1,800 Nm
Dimensions (L x W x H)	217x94x303 mm
Net weight	4.2 kg

AVAILABLE VARIANTS

4.0Ah	"Z" VARIANT
TW001G M2 <small>INCLUDES 2 BATTERIES / 1 CHARGER / MAKPAC CONNECTOR CASE</small>	TW001G Z <small>TOOL ONLY (DOES NOT INCLUDE BATTERY / CHARGER / CARRYING CASE)</small>

TW005G 1/2"

Acc Pg. A032-036

40V MAX XGT - Cordless Impact Wrench



Full Speed Mode

Switches between variable and full speed by pressing the button. Reaches full speed with fewer pull trigger to minimize user's fatigue in continuous work

Specifications:-

Fastening Capacities	Standard Bolt: M10 - M20 High Strength Bolt: M10 - M16
Square Drive	12.7 (1/2)
No Load Speed (RPM)	Max /H/M/S: 0 - 3,200 / 0 - 2,600 / 0 - 1,800 / 0 - 1,000
Impacts Per Minute (IPM)	Max /H/M/S: 0 - 4,000 / 0 - 3,400 / 0 - 2,600 / 0 - 1,800
Max Fastening Torque	350 Nm
Dimensions (L x W x H)	144x86x248 mm
Net weight	2.2 kg



Nut buster Impact Wrench with over 630N.m Torque

- Reverse Rotation Auto Stop Mode stops after the bolt/nut loosened enough
- Single speed mode for reduced trigger-pulling force

Electronic 4 stage impact power selection

Enables user to control the power and speed depending on the applications

AVAILABLE VARIANTS

4.0Ah	"Z" VARIANT
TW005G M2 INCLUDES 2 BATTERIES / 1 CHARGER / MAKPAC CONNECTOR CASE	TW005G Z TOOL ONLY (DOES NOT INCLUDE BATTERY / CHARGER / CARRYING CASE)

CORDLESS

FIXING / FASTENING

DRILLING / IMPACT DRILLING

CONCRETE DRILLING / DEMOLITION

CUTTING [CONCRETE/ MASONRY/ METAL]

MULTI TOOL

GRINDING

SANDING / POLISHING

SAWING

ROUTERING / PLANING

CLEANING

HEAT GUN / LASERS

PNEUMATIC TOOLS

GARDEN TOOLS

GENERATORS

3/4" IMPACT WRENCH COMPARISON CHART

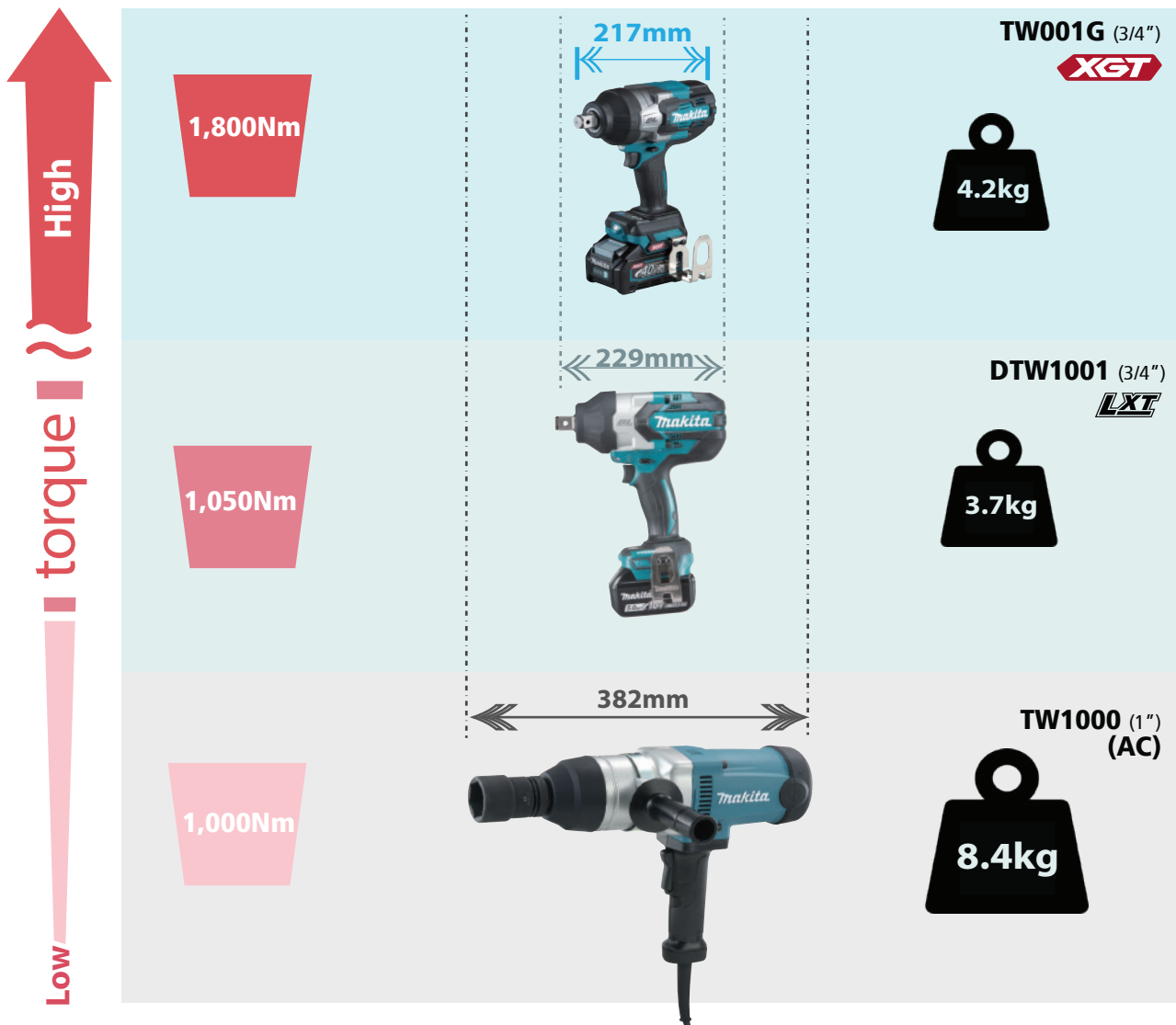

- CORDLESS
- FIXING / FASTENING
- DRILLING / IMPACT DRILLING
- CONCRETE DRILLING / DEMOLITION
- CUTTING [CONCRETE/ MASONRY/ METAL]
- MULTI TOOL
- GRINDING
- SANDING / POLISHING
- SAWING
- ROUTERING / PLANING
- CLEANING
- HEAT GUN / LASERS
- PNEUMATIC TOOLS
- GARDEN TOOLS
- GENERATORS

XGT Combination Hammers

Anti Vibration Technology

Anti vibration grip Counterweight mechanism



Vibration absorbing handle

SOFT NO LOAD
Automatically reduces the motor speed during idling to suppress the vibration (Soft no load is only for HR002G)

Vibration Level **7.0 m/s²**

Auto-start Wireless System [HR002G]



Connects to compatible Dust Extractor with Bluetooth. Dust extractor starts automatically when the tool starts. Also dust extractor stops on its own when the tool is in rest

Bluetooth
Switch on the tool

Vacuum cleaner is activated

Bluetooth Chip (Optional)
Part #: 198900-7



Good Tool Balance for Increased Operability



Center of gravity

The tool's center of gravity is located as close to the handle grip as possible, providing more control and less fatigue

Active Feedback Sensing Technology [HR002G]

Smart function to minimize the danger of kick-back
Shuts down the tool if the rotation speed suddenly slows down

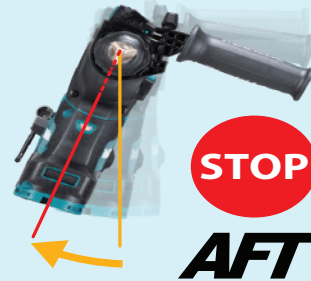

Dust Extraction System for effective cleaning



HR002G 28mm Acc Pg. A062-079

40V MAX XGT - Cordless Combination Hammer



40V MAX XGT **BLAFTAWS AVT SOFT XPT** **NEW**

Quick change drill chuck 199139-5 (standard)

3 mode

3.2J

Excellent drilling performance, Extremely compact & lightweight combination hammer

- Good Tool Balance for Increased Operability
- Anti-Vibration Technology (AVT) for low vibration
- Auto-start Wireless System (AWS) connects to vacuum cleaner with Bluetooth
- Active Feedback sensing Technology (AFT) turns the motor off if bit rotation is suddenly forced to stop

Specifications:-

Impact Energy	3.2 J
Capacity	Concrete 28 / Steel 13 / Wood 32 / Core Bit 54 / Diamond Core Bit (Dry Type) 65 mm
Blows Per Minute (BPM)	0 - 5,000
No Load Speed (RPM)	0 - 980
Chuck Capacity	1.5 - 13 mm
Sound Pressure Level	93 dB(A)
Sound Power Level	104 dB(A)
Dimensions (L x W x H)	404x102x238 mm
Net weight	4.6 kg

Standard Equipment: Side Grip, Depth Gauge, QCD chuck

AVAILABLE VARIANTS	
4.0Ah	"Z" VARIANT
HR002G M2 INCLUDES 2 BATTERIES / 1 CHARGER / MAKPAC CONNECTOR CASE	HR002G Z TOOL ONLY (DOES NOT INCLUDE BATTERY / CHARGER / BLUETOOTH CHIP / CARRYING CASE)

HR003G 28mm Acc Pg. A062-079

40V MAX XGT - Cordless Combination Hammer



40V MAX XGT **BLAVT XPT** **NEW**

3 mode

3.2J

Excellent drilling performance, Extremely compact & lightweight combination hammer

- Good Tool Balance for Increased Operability
- Anti-Vibration Technology (AVT) for low vibration

Specifications:-

Impact Energy	3.2 J
Capacity	Concrete 28 / Steel 13 / Wood 32 / Core Bit 54 / Diamond Core Bit (Dry Type) 65 mm
Blows Per Minute (BPM)	0 - 5,000
No Load Speed (RPM)	0 - 980
Chuck Capacity	1.5 - 13 mm
Sound Pressure Level	95 dB(A)
Sound Power Level	106 dB(A)
Dimensions (L x W x H)	373x102x238 mm
Net weight	4.6 kg

Standard Equipment: Side Grip, Depth Gauge

AVAILABLE VARIANTS	
4.0Ah	"Z" VARIANT
HR003G M2 INCLUDES 2 BATTERIES / 1 CHARGER / MAKPAC CONNECTOR CASE	HR003G Z TOOL ONLY (DOES NOT INCLUDE BATTERY / CHARGER / CARRYING CASE)

The Dust Extractor Attachment with HEPA Filter to capture concrete dust during drilling
Overall length: : 260mm



NEW

HEPA filter

Depth gauge
can be adjusted for desired drilling depth simply by pushing a single push button

Dust collection inlet
can be adjusted according to bit length simply by pushing a single push button.

Transparent dust case
for easy checking of collected dust amount

Filter cleaning mechanism
by turning the dial, the dust falls off from the filter.

Twin LED job light with preglow and afterglow functions
LED job light is also installed on Dust collection system.

Large dust case cover
can be opened simply by pushing a single push button for easy dust cleaning.

	DX14 (191E58-1)	DX12 (191E52-3)
Compatible tool	HR002G	HR003G
Method to run Dust collection system	Built-in DC motor	Built-in DC motor
Dust box capacity: mL	400	400
Attachable bit size (W x L)	28x260mm	28x260mm
Usable length	190 mm	190 mm
Dimensions (L x W x H)	593mmx102x313mm	626mmx102x320mm
Net weight	1.6kg	1.6kg

- CORDLESS
- FIXING / FASTENING
- DRILLING / IMPACT DRILLING
- CONCRETE DRILLING / DEMOLITION
- CUTTING [CONCRETE/ MASONRY/ METAL]
- MULTI TOOL
- GRINDING
- SANDING / POLISHING
- SAWING
- ROUTERING / PLANING
- CLEANING
- HEAT GUN / LASERS
- PNEUMATIC TOOLS
- GARDEN TOOLS
- GENERATORS

GA004G 115mm Acc Pg. A101-128

40V MAX XGT - Cordless Angle Grinder

Excellent in continuous heavy-duty work Slide Switch Angle Grinders

- High durability with BL motor
- New tool-less wheel cover
- AFT - Shuts down the tool, if the rotation speed suddenly slows down
- Equipped with Anti-restart function, Electric brake and Soft start

Specifications:-

Wheel Diameter	115 mm
Hole Diameter	22.23 mm
No Load Speed (RPM)	8,500
Sound Pressure Level	81 dB(A)
Sound Power Level	92 dB(A)
Dimensions (L x W x H)	410x130x168 mm
Net weight	3.5 kg

Standard Equipment: Toolless Wheel Cover, Side Handle, Lock Nut Wrench

AVAILABLE VARIANTS	
4.0Ah	"Z" VARIANT
GA004G M2 INCLUDES 2 BATTERIES / 1 CHARGER / MAKPAC CONNECTOR CASE	GA004G Z TOOL ONLY (DOES NOT INCLUDE BATTERY / CHARGER / CARRYING CASE)

GA005G 125mm Acc Pg. A101-128

40V MAX XGT - Cordless Angle Grinder

Excellent in continuous heavy-duty work Slide Switch Angle Grinders

- High durability with BL motor
- New tool-less wheel cover
- AFT - Shuts down the tool, if the rotation speed suddenly slows down
- Equipped with Anti-restart function, Electric brake and Soft start

Specifications:-

Wheel Diameter	125 mm
Hole Diameter	22.23 mm
No Load Speed (RPM)	8,500
Sound Pressure Level	81 dB(A)
Sound Power Level	92 dB(A)
Dimensions (L x W x H)	410x140x168 mm
Net weight	3.6 kg

Standard Equipment: Toolless Wheel Cover, Side Handle, Lock Nut Wrench

AVAILABLE VARIANTS	
4.0Ah	"Z" VARIANT
GA005G M2 INCLUDES 2 BATTERIES / 1 CHARGER / MAKPAC CONNECTOR CASE	GA005G Z TOOL ONLY (DOES NOT INCLUDE BATTERY / CHARGER / CARRYING CASE)

GA012G 115mm Acc Pg. A101-128

40V MAX XGT - Cordless Angle Grinder

Excellent in continuous heavy-duty work Paddle Switch Angle Grinders

- High durability with BL motor
- New tool-less wheel cover
- AFT - Shuts down the tool, if the rotation speed suddenly slows down
- Equipped with Anti-restart function, Electric brake and Soft start

Specifications:-

Wheel Diameter	115 mm
Hole Diameter	22.23 mm
No Load Speed (RPM)	8,500
Sound Pressure Level	81 dB(A)
Sound Power Level	92 dB(A)
Dimensions (L x W x H)	410x130x168 mm
Net weight	3.5 kg

Standard Equipment: Toolless Wheel Cover, Side Handle, Lock Nut Wrench

AVAILABLE VARIANTS	
4.0Ah	"Z" VARIANT
GA012G M2 INCLUDES 2 BATTERIES / 1 CHARGER / MAKPAC CONNECTOR CASE	GA012G Z TOOL ONLY (DOES NOT INCLUDE BATTERY / CHARGER / CARRYING CASE)

GA013G 125mm Acc Pg. A101-128

40V MAX XGT - Cordless Angle Grinder

Excellent in continuous heavy-duty work Paddle Switch Angle Grinders

- High durability with BL motor
- New tool-less wheel cover
- AFT - Shuts down the tool, if the rotation speed suddenly slows down
- Equipped with Anti-restart function, Electric brake and Soft start

Specifications:-

Wheel Diameter	125 mm
Hole Diameter	22.23 mm
No Load Speed (RPM)	8,500
Sound Pressure Level	81 dB(A)
Sound Power Level	92 dB(A)
Dimensions (L x W x H)	410x140x168 mm
Net weight	3.6 kg

Standard Equipment: Toolless Wheel Cover, Side Handle, Lock Nut Wrench

AVAILABLE VARIANTS	
4.0Ah	"Z" VARIANT
GA013G M2 INCLUDES 2 BATTERIES / 1 CHARGER / MAKPAC CONNECTOR CASE	GA013G Z TOOL ONLY (DOES NOT INCLUDE BATTERY / CHARGER / CARRYING CASE)

- CORDLESS
- FIXING / FASTENING
- DRILLING / IMPACT DRILLING
- CONCRETE DRILLING / DEMOLITION
- CUTTING [CONCRETE / MASONRY / METAL]
- MULTI TOOL
- GRINDING
- SANDING / POLISHING
- SAWING
- ROUTERING / PLANING
- CLEANING
- HEAT GUN / LASERS
- PNEUMATIC TOOLS
- GARDEN TOOLS
- GENERATORS

CORDLESS
FIXING / FASTENING
DRILLING / IMPACT DRILLING
CONCRETE DRILLING / DEMOLITION
CUTTING [CONCRETE/ MASONRY/ METAL]
MULTI TOOL
GRINDING
SANDING / POLISHING
SAWING
ROUTERING / PLANING
CLEANING
HEAT GUN / LASERS
PNEUMATIC TOOLS
GARDEN TOOLS
GENERATORS

GA022G 115mm Acc Pg. A101-128

40V MAX XGT - Cordless Angle Grinder



Excellent in continuous heavy-duty work Slide Switch Angle Grinders with AWS function

- High durability with BL motor
- New tool-less wheel cover
- AFT - Shuts down the tool, if the rotation speed suddenly slows down
- Equipped with Anti-restart function, Electric brake and Soft start
- Variable speed control dial matches the speed to your application.

Specifications:-

Wheel Diameter	115 mm
Hole Diameter	22.23 mm
No Load Speed (RPM)	3,000 - 8,500
Sound Pressure Level	81 dB(A)
Sound Power Level	92 dB(A)
Dimensions (L x W x H)	425x130x168 mm
Net weight	3.6 kg

Standard Equipment: Toolless Wheel Cover, Side Handle, Lock Nut Wrench

AVAILABLE VARIANTS	
4.0Ah	"Z" VARIANT
GA022G M2 INCLUDES 2 BATTERIES / 1 CHARGER / MAKPAC CONNECTOR CASE (DOES NOT INCLUDE BLUETOOTH CHIP)	GA022G Z TOOL ONLY (DOES NOT INCLUDE BATTERY / CHARGER / BLUETOOTH CHIP / CARRYING CASE)

GA023G 125mm Acc Pg. A101-128

40V MAX XGT - Cordless Angle Grinder



Excellent in continuous heavy-duty work Slide Switch Angle Grinders with AWS function

- High durability with BL motor
- New tool-less wheel cover
- AFT - Shuts down the tool, if the rotation speed suddenly slows down
- Equipped with Anti-restart function, Electric brake and Soft start
- Variable speed control dial matches the speed to your application.

Specifications:-

Wheel Diameter	125 mm
Hole Diameter	22.23 mm
No Load Speed (RPM)	3,000 - 8,500
Sound Pressure Level	81 dB(A)
Sound Power Level	92 dB(A)
Dimensions (L x W x H)	425x140x168 mm
Net weight	3.6 kg

Standard Equipment: Toolless Wheel Cover, Side Handle, Lock Nut Wrench

AVAILABLE VARIANTS	
4.0Ah	"Z" VARIANT
GA023G M2 INCLUDES 2 BATTERIES / 1 CHARGER / MAKPAC CONNECTOR CASE (DOES NOT INCLUDE BLUETOOTH CHIP)	GA023G Z TOOL ONLY (DOES NOT INCLUDE BATTERY / CHARGER / BLUETOOTH CHIP / CARRYING CASE)

GA028G 115mm Acc Pg. A101-128

40V MAX XGT - Cordless Angle Grinder



Excellent in continuous heavy-duty work Paddle Switch Angle Grinders with AWS function

- High durability with BL motor
- New tool-less wheel cover
- AFT - Shuts down the tool, if the rotation speed suddenly slows down
- Equipped with Anti-restart function, Electric brake and Soft start
- Variable speed control dial matches the speed to your application.

Specifications:-

Wheel Diameter	115 mm
Hole Diameter	22.23 mm
No Load Speed (RPM)	3,000 - 8,500
Sound Pressure Level	81 dB(A)
Sound Power Level	92 dB(A)
Dimensions (L x W x H)	425x130x168 mm
Net weight	3.6kg

Standard Equipment: Toolless Wheel Cover, Side Handle, Lock Nut Wrench

AVAILABLE VARIANTS	
4.0Ah	"Z" VARIANT
GA028G M2 INCLUDES 2 BATTERIES / 1 CHARGER / MAKPAC CONNECTOR CASE (DOES NOT INCLUDE BLUETOOTH CHIP)	GA028G Z TOOL ONLY (DOES NOT INCLUDE BATTERY / CHARGER / BLUETOOTH CHIP / CARRYING CASE)

GA029G 125mm Acc Pg. A101-128

40V MAX XGT - Cordless Angle Grinder



Excellent in continuous heavy-duty work Paddle Switch Angle Grinders with AWS function

- High durability with BL motor
- New tool-less wheel cover
- AFT - Shuts down the tool, if the rotation speed suddenly slows down
- Equipped with Anti-restart function, Electric brake and Soft start
- Variable speed control dial matches the speed to your application.

Specifications:-



Wheel Diameter	125 mm
Hole Diameter	22.23 mm
No Load Speed (RPM)	3,000 - 8,500
Sound Pressure Level	82 dB(A)
Sound Power Level	93 dB(A)
Dimensions (L x W x H)	425x140x168 mm
Net weight	3.6 kg

Standard Equipment: Toolless Wheel Cover, Side Handle, Lock Nut Wrench

AVAILABLE VARIANTS	
4.0Ah	"Z" VARIANT
GA029G M2 INCLUDES 2 BATTERIES / 1 CHARGER / MAKPAC CONNECTOR CASE (DOES NOT INCLUDE BLUETOOTH CHIP)	GA029G Z TOOL ONLY (DOES NOT INCLUDE BATTERY / CHARGER / BLUETOOTH CHIP / CARRYING CASE)

HS004G 185/190mm Acc Pg. A143-160

40V MAX XGT - Cordless Circular Saw

XGT 40Vmax BL ADT XPT AWS  



Excellent balance and High power machine with AWS function

- Lightweight & High Power
- BL motor delivers 6,000 RPM for fast cutting
- Automatic torque Drive Technology (ADT) adjusts cutting speed and torque during cut for optimum performance
- Blinks green to indicate that the tool is overloaded ADT indicator lamp
- Compatible with guide rail without adapter

Specifications:- 

Blade Diameter	190 / 185 mm
Bore Diameter	20mm
Max Cutting Capacity	90°: 62.5 / 60 mm
	45°: 44.5 / 43 mm
	48°: 42 / 41 mm
No Load Speed (RPM)	6,000
Dimensions (L x W x H)	337x210x290 mm
Net weight	4.7 kg

Standard Equipment: Hex Wrench, Guide Rule

AVAILABLE VARIANTS

4.0Ah	"Z" VARIANT
HS004G M2 INCLUDES 2 BATTERIES / 1 CHARGER / BLUETOOTH CHIP / MAKIPAC CONNECTOR CASE	HS004G Z TOOL ONLY (DOES NOT INCLUDE BATTERY / CHARGER / BLUETOOTH CHIP / CARRYING CASE)

CF001G

40V MAX XGT - Lithium-ion Cordless Fan

XGT 40Vmax 



Quiet running & Powerful wind with 40V MAX XGT battery

- 235 mm large fan produces strong enough air to create a comfortable work environment
- AC/DC dual power source: AC adapter or Makita XGT Li-Ion battery
- Automatically swings 45° L/R
- Up to 11 hours of continuous runtime on low speed with 4.0Ah XGT battery
- 3 settings (High 190 m/min, Medium 150 m/min, Low 120 m/min)

Specifications:- 

Continuous Use (min.) w/o oscillation	w/ BL4040 Low / Mid / High: 1,160 / 880 / 660
Continuous Use (min.) w/ oscillation	w/ BL4040 Low / Mid / High: 1,055 / 800 / 600
Max Air Velocity	High / Mid / Low: 190 / 150 / 120 m/min
Air Flow	High / Mid / Low: 8.2 / 6.5 / 5.2 m³/min
Fan Diameter	235 mm
Noise Level	48 dB(A) (w/ high speed)
Dimensions (L x W x H)	143x333x463 mm
Net weight	3.0 kg

Standard Equipment: AC adapter



AVAILABLE VARIANTS

4.0Ah	"Z" VARIANT
	CF001G Z TOOL ONLY (DOES NOT INCLUDE BATTERY / CHARGER OR CARRY CASE)

JR001G Acc Pg. A155-156

40V MAX XGT - Cordless Reciprocating Saw

XGT 40Vmax BL XPT 

Lightweight, Powerful, Durable and Built to perform

- An efficient brushless reciprocating saw for spark-free cutting of metal and demolition work for professional use.
- Rubber joint structure
- Blade ejection lever is located on the housing side for increased operability

Smooth cutting with vertical crank system



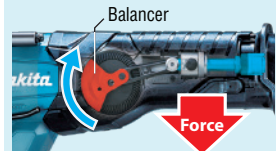

The crank mechanism has been designed to rotate vertically to provides less vibration to the user

Tool-less shoe adjustment



Lever system has been designed for easier adjustment



Specifications:- 

Length of Stroke	32 mm
Strokes Per Minute (SPM)	High / Low: 0 - 3,000 / 0 - 2,300
Capacity	Pipe : 130 mm / Wood: 255 mm
Sound Pressure Level	85 dB(A)
Sound Power Level	96 dB(A)
Dimensions (L x W x H)	472x88x239 mm
Net weight	4.5kg

AVAILABLE VARIANTS

4.0Ah	"Z" VARIANT
JR001G M2 INCLUDES 2 BATTERIES / 1 CHARGER / PLASTIC CASE	JR001G Z TOOL ONLY (DOES NOT INCLUDE BATTERY / CHARGER / CARRYING CASE)

CORDLESS

FIXING / FASTENING

DRILLING / IMPACT DRILLING

CONCRETE DRILLING / DEMOLITION

CUTTING [CONCRETE / MASONRY / METAL]

MULTI TOOL

GRINDING

SANDING / POLISHING

SAWING

ROUTERING / PLANING

CLEANING

HEAT GUN / LASERS

PNEUMATIC TOOLS

GARDEN TOOLS

GENERATORS



VIDEO CLIP

18V X2 Lithium-ion

Powered by two 18V Li-ion
LXT batteries in series

18V + 18V → 36V LXT



EXPAND YOUR LITHIUM-ION LINEUP

Lawn Mower
DLM460 / DLM382 / DLM432 /
DLM462 / DLM530 / DLM532 /
DLM533

Chain Saw
DUC405 / DUC400 / DUC355 /
DUC353 / DUC305 / DUC303 /
DUC302 / DUC252 / DUC252C /
DUC256 / DUC306 / DUC356 /
DUC406

Blower
DUB361 /
DUB362 /
DUB363

Hedge Trimmer
DUH551 / DUH651

Grass Trimmer
DUR364L / DUR368A /
DUR368L / DUR369A /
DUR369L / DUR369N

Battery Powered Pruning Shears
DUP361 / DUP362

Multi Function Power Head
DUX60

Battery Converter
BCV01

Backpack Vacuum Cleaner
DVC261 / DVC265 /
DVC660 / DVC665

Corded and Cordless Vacuum Cleaner
DVC860L / DVC861L /
DVC150L / DVC151L

Combination Hammer
DHR263 / DHR264 /
DHR280, DHR282+DX08 /
DHR281, DHR283+DX09

Rotary Hammer
DHR400N

Angle Grinder
DGA701 / DGA901 /
DGA700 / DGA900

Recipro Saw
DJR360

Portable Cut-off
DLW140

Slide Compound Miter Saw
DLS714 / DLS110 / DLS111 /
DLS112 / DLS211 / DLS212

Circular Saw
DHS710 / DHS711 / DHS781 /
DHS780 / DHS782 / DHS783 /
DHS900 / DHS901

Battery Converter
BCV03

Power Cutter
DCE090

Rear Handle Saw
DRS780

Battery Adapter
BAP182

Plunge Cut Saw
DSP600 / DSP601

Angle Drill
DDA460

Vacuum Cleaner
DVC865L / DVC866L / DVC867L /
DVC155L / DVC156L / DVC157L

Shear Wrench
DWT310

The Makita twin 18V battery concept offers an expanding range of machines that utilise the established 18V Lithium-ion battery capacity to deliver high power 36V performance whilst offering an economic purchase solution for existing Makita tool owners.

Note: When different capacity batteries are used together (for example, 18V Li-ion 3.0Ah and 5.0Ah, or fully charged 5.0Ah and 70% charged 5.0Ah), the machine stops when the battery with the less capacity gets empty.

Go Green with Makita Lithium-ion Cordless Garden Tools

Best choice for resorts, hotels, public places and among residential areas due to

ZERO EMISSION + **ZERO** POLLUTION + **LOW** NOISE + **LOW** VIBRATION + **EASY** MAINTENANCE

NO PETROL NO HASSLES

As a global supplier of a comprehensive range of power tools and garden tools that assist people in creating homes and living environments, it is vital that we consider the environmental impact on each person's lifestyle and recognize that environmental issues such as global warming concern us directly. Makita offers a range of cordless garden tools which are engineered to use with long-life lithium-ion batteries to save energy, eliminate CO2 emissions, preserve the environment and light in weight for user's comfort.

Our 18v+18v lithium-ion cordless garden tools are friendly to both users and the environment



The "Go Green" slogan symbolizes Makita's commitment to continually providing new value as a comprehensive international supplier of tools. We hope to always remain a company that maintains a steady eye on society, challenging ourselves to create a "sustainable recycling-oriented society" that combines the environment with the economy

Cordless Garden Tools advantage

Easy to Use



Start-up

ENGINE TOOLS



Engine tools need time and tips to start-up.

CORDLESS TOOLS



Cordless tools start just after inserting battery and switching on.

Constant speed control

ENGINE TOOLS



Engine tools are hard to keep the constant rotation speed under load.

CORDLESS TOOLS



Cordless tools keep rotation speed under load with "Constant speed control" function.

Low noise Noise level comparison

ENGINE TOOLS



CORDLESS TOOLS



Clean & Easy Maintenance



Zero emission

ENGINE TOOLS

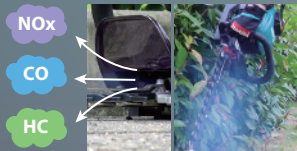

CORDLESS TOOLS



Cordless tools don't generate any exhaust gas

Cost and time reduction

ENGINE TOOLS



It takes time to prepare mixed fuel for Engine.

CORDLESS TOOLS



Just insert battery and ready to use.

Easy maintenance

ENGINE TOOLS

Engine tools take time for maintenance.

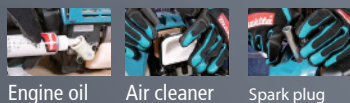

Engine oil Air cleaner Spark plug

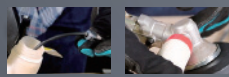

Fuel plug Grease up

CORDLESS TOOLS

Cordless tools are maintenance-free unlike Engine tools.



Long term storage

ENGINE TOOLS

If you store the tool for a long period, when the fuel remained in the tank

It may be a cause of trouble or defect.

Remaining fuel must be extracted completely before storage.



CORDLESS TOOLS

Even if you store the tools for a long period,

Just insert battery and ready to use.



PDC01

Portable Backpack Power Pack (Compatible with LXT Li-ion Tools)

Backpack utilizes four Lithium-Ion batteries to provide longer run time for 18V+18V Li-ion Tools

- 2 times the runtime with 18Vx2 tools
- 4 times the runtime with 18V tools



Detachable Battery Box

Battery box can be detached from the harness for use as a stationary power supply



Shoulder harness

with easily adjustable belt and straps for improved balance

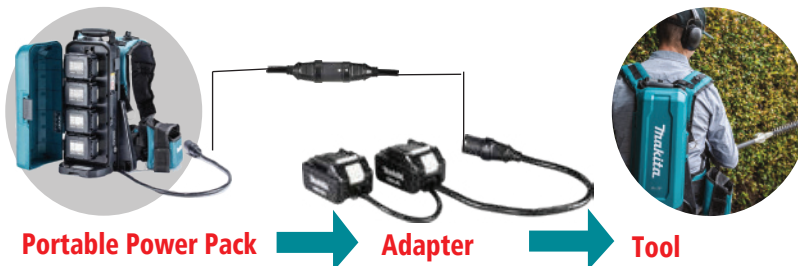

Connector cord

Compatible with 18V+ 18V adapter (Standard)



18V adapter (Sold Separately)



Compatible with entire LXT series (300+ Tools)



Specification	
Voltage	18V
Compatibility	For 18V LXT / 18V LXT x 2 (36V) tools
Battery Fuel Gauge	Yes (indicator for each battery)
USB port	NO
Main power switch with auto-off function	YES
Length of cable	1.7m (Cable to tool)
Dimensions (LxWxH)	400x195x132mm
Net weight (with 4 pcs. of BL1860B)	Battery box: 5.5kg Battery box with Harness: 7.0kg

Available Variants					
TYPE	VARIANTS	BATTERIES	CHARGER	ADPATER	CARRY CASE
W/O BATTERY/CHARGER	PDC01 (191A67-6)	0	0	18V + 18V Adapter	-

Accessories	
18V + 18V Adapter Part No. 191J51-5 (Standard)	18V Adapter Part No. 191J50-7 (Optional)



CORDLESS

FIXING / FASTENING

DRILLING / IMPACT DRILLING

CONCRETE DRILLING / DEMOLITION

CUTTING [CONCRETE/ MASONRY/ METAL]

MULTI TOOL

GRINDING

SANDING / POLISHING

SAWING

ROUTERING / PLANING

CLEANING

HEAT GUN / LASERS

PNEUMATIC TOOLS

GARDEN TOOLS

GENERATORS

CORDLESS

FIXING / FASTENING

DRILLING / IMPACT DRILLING

CONCRETE DRILLING / DEMOLITION

CUTTING [CONCRETE/ MASONRY/ METAL]

MULTI TOOL

GRINDING

SANDING / POLISHING

SAWING

ROUTERING / PLANING

CLEANING

HEAT GUN / LASERS

PNEUMATIC TOOLS

GARDEN TOOLS

GENERATORS

DUX60

Acc Pg. A204-213

18V+18V LXT - Lithium-ion Cordless Multi Function Power Head



DUX60 is as powerful as petrol engine tool EX2650LH without kickback.

DUX60 is for users with multiple garden applications such as trimming, edging, cultivating, and brush cutting with different attachments. This reduces the need for purchasing multiple tools for different applications thereby saving cost and space.

One tool for all your garden needs

Easy Change

Lever style lock system allows for quick toolless installation and replacement of the attachments

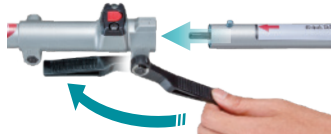

Active Feedback sensing Technology

turns the motor off if rotation speed suddenly slows

ON-OFF button with Auto-OFF for Safety operation

Automatically power off if no operation for one minute or more.



High Power Brushless Motor provides high operating efficiency

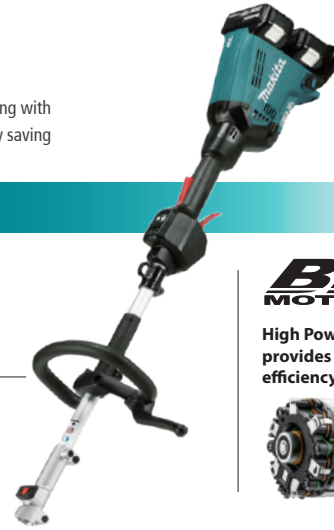

Ground trimmer
EN420MP
198060-5

Hedge trimmer
Straight / Angle
EN410MP / EN401MP
197740-0 / 196342-9

Cultivator
KR400MP
195713-7
Cutting width: 160mm

KR401MP
199188-2
Cutting width: 220mm

Brushcutter
EM400MP
195654-7

String trimmer
ER400MP
195528-2

Power sweep attachment
SW400MP
199347-8
water can be swept away from the surface. Sweeping dust, fallen leaves, or snow on the ground

Power brush attachment
BR400MP
199326-6
Cleaning of pavement with many joints and uneven stones using nylon brush

Shaft extension attachment
LE400MP
196032-4
Length: 1,080mm (42-1/2")
For Pole saw, Pole hedge trimmer and coffee harvester

Blower Set NEW
UR400MP
191F72-3
New solution for fast clean-ups

Pole saw
EY401MP
196104-5

Edger
EE400MP
196752-0

Specifications:-



Max output power: W	600
No Load Speed (RPM)	High: 0 - 9,700 / Medium: 0 - 8,200 / Low: 0 - 5,700
Constant speed control	Yes
Variable speed control	By Trigger + By Button (3-speed selection)
Grass clipping removal function	Yes
Dimensions (L x W x H)	1,011x320x216 mm
Net weight	5.0kg

Standard Equipment: Harness, Safety Goggles, Hex Wrench

AVAILABLE VARIANTS		
5.0Ah	3.0Ah	"Z" VARIANT
		DUX60 Z TOOL ONLY (DOES NOT INCLUDE BATTERY / CHARGER)

DUC405 400mm (16") Acc Pg. A207-208

18V+18V LXT - Lithium-ion Cordless Chain Saw



High Power & High Speed Chain

Efficiency equivalent to 30mL class engine chain saw

1) High operating efficiency

Powerful Outer Rotor Brushless Motor

2) High operability equivalent to engine chain saw

Kickback brake and Variable speed trigger switch

3) Easy to switch on

Built-in L.E.D. on/off switch with auto power-off function; automatically shuts the saw off when operation is delayed for extended battery life. Also easy to switch on the chain saw.

4) Built-in lock-off lever

helps prevent the blade from accidentally engaging

Front-hand-guard-activated kickback brake

Battery capacity warning lamp

Soft grip for non-skid operation

Metal spike bumper

Firmly grips workpiece to provide more control, making cutting easier

With Captive nuts for solid bar retention



Work amount*
650cut
BL1860B x2

Work amount (approx): cuts (Cut 50mm x 50mm cedar timber with 91PX saw chain under the normal condition)

Specifications:-

Guide Bar Length	400 mm (16")
Cutting Length	370 mm (14-1/2")
Chain Pitch	3/8"
Chain Gauge	1.1 / 1.3 mm (0.043" / 0.050")
Chain Speed	0 - 20 m/s (0 - 1,200 m/min) (0 - 3,940 FPM)
Chain Oil Tank Volume	200 mL
Vibration Level	Cutting Wood: 5.3 m/s ²
Dimensions (L x W x H)	800x211x235 mm
Net weight	5.5 kg

Standard Equipment: Saw Chain, Guide Bar, Guide Bar Cover

AVAILABLE VARIANTS		
5.0Ah	3.0Ah	"Z" VARIANT
DUC405 PT2 INCLUDES 2 BATTERIES / 1 TWO PORT CHARGER	-	DUC405 Z TOOL ONLY (DOES NOT INCLUDE BATTERY / CHARGER)

DUC252 250mm (10") Acc Pg. A207-208 **442**

18V+18V LXT Lithium-ion Cordless Chain Saw



Carving Bar



Cordless chain saws powered by two 18V Li-ion batteries

- Tool-less chain adjustment for convenient operation and maintenance
- Kickback brake & electric brake for maximum productivity and maximum operator safety
- Soft start feature gradually increases speed to eliminate start up shock

Work amount*

675cut
BL1860B x2

Specifications:-



Work amount (approx): cuts (Cut 50mm x 50mm cedar timber with 91PX saw chain under the normal condition)

Guide Bar Length	250 mm (10")
Chain Pitch	9.5 mm (3/8")
Chain Gauge	1.3 mm (0.050")
Chain Speed	8.3 m/s (500 m/min) (1,650 FPM)
Chain Oil Tank Volume	85 mL (2.9 US oz)
Dimensions (L x W x H)	w/o Guide Bar: 316x234x198 mm
Net weight	4.7 kg

Standard Equipment: Saw Chain, Guide Bar, Guide Bar Cover,

AVAILABLE VARIANTS		
5.0Ah	3.0Ah	"Z" VARIANT
DUC252 PT2 INCLUDES 2 BATTERIES / 1 TWO PORT CHARGER	DUC252 RF2 INCLUDES 2 BATTERIES / 1 CHARGER	DUC252 Z TOOL ONLY (DOES NOT INCLUDE BATTERY / CHARGER)

Accessories

For Model	Guide Bar		Saw Chain					Bar Cover Part No.	
	Bar Length	Bar Type	Guide Bar Part No.	Cutter Type	Gauge	Pitch	Drive Links		Saw blade Part No.
DUC405 (standard)	40cm/16"	Sprocket	165202-6	91 CC	1.3mm	3/8"	56	511492756	419560-5
DUC405 (optional)	40cm/16"	Sprocket (Micro-Lite)	165247-4	90 PX	1.1mm	3/8"	56	196742-3	419560-5
DUC252 (standard)	25cm/10"	Sprocket	168408-5	91 VG	1.3mm	3/8"	40	196205-9	-
DUC252 (optional)	25cm/10"	Sprocket	161846-0	90 PX	1.1mm	3/8"	40	199075-5	-



CORDLESS

FIXING / FASTENING

DRILLING / IMPACT DRILLING

CONCRETE DRILLING / DEMOLITION

CUTTING [CONCRETE / MASONRY / METAL]

MULTI TOOL

GRINDING

SANDING / POLISHING

SAWING

ROUTERING / PLANING

CLEANING

HEAT GUN / LASERS

PNEUMATIC TOOLS

GARDEN TOOLS

GENERATORS

- CORDLESS
- FIXING / FASTENING
- DRILLING / IMPACT DRILLING
- CONCRETE DRILLING / DEMOLITION
- CUTTING (CONCRETE/ MASONRY/ METAL)
- MULTI TOOL
- GRINDING
- SANDING / POLISHING
- SAWING
- ROUTERING / PLANING
- CLEANING
- HEAT GUN / LASERS
- PNEUMATIC TOOLS
- GARDEN TOOLS
- GENERATORS

DUH551 550mm (21-5/8")

Acc Pg. A209 442

18V+18V LXT Lithium-Ion Cordless Hedge Trimmer

High maneuverability and environment friendly.
5 position adjustable handle
 Locks at 45° and 90° left and right and 0°, for easy and fast trimming in any angle.

Well balanced tool design
 by positioning the batteries at rear end of the tool.

Runtime*

75-125min

BL1850B x2

*No load continuous run time (approx)

Specifications:-

Blade length	550mm (21-5/8")
Strokes per minute(spm)	2,000-3,600
Sound pressure level	81.5dB(A)
Sound power level	91dB(A)
Dimensions (L x W x H)	1,065 x 225 x 200mm
Max. output	0.32kW
Net weight	5.1kg (11.3lbs)

Standard Equipment: Blade cover.

AVAILABLE VARIANTS		
5.0Ah	3.0Ah	"Z" VARIANT
		DUH551 Z TOOL ONLY (DOES NOT INCLUDE BATTERY / CHARGER)



UR101C / UR201C

Acc Pg. A210-212

18V+18V LXT Lithium-Ion Cordless Battery Powered Grass Trimmer

ADAPT TO METAL BLADE

- Used with PDC01 power source kit
- Excellent tool in continuous work
- High power 1 kW equivalent to petrol tool
- Electronic -3Speed control

Reverse switch
for clearing entangled weeds and grass from cutting head

NYLON CUTTING HEAD

PLASTIC BLADE

BL Motor
Rear end mounted brushless motor makes the tool balance similar to engine grass trimmers

Loop handle (UR201C)

Offset handle (UR101C)
Enabling user to work with less fatigue even in long continuous operation and allowing for a wider swing.

PDC01
Portable power source (sold separately)
(Can adapt upto four 18v LXT batteries)

NEW

Specifications:-

Cutting Width		
No Load Speed (RPM)		
Spindle Size		
Vibration Level		
Dimensions (L x W x H)		
Net weight		

Standard Equipment: Safety Goggles, Hex Wrench

AVAILABLE VARIANTS		
5.0Ah	3.0Ah	"Z" VARIANT
		UR101C Z TOOL ONLY (DOES NOT INCLUDE BATTERY / CHARGER)

AVAILABLE VARIANTS		
5.0Ah	3.0Ah	"Z" VARIANT
		UR201C Z TOOL ONLY (DOES NOT INCLUDE BATTERY / CHARGER)

DUR369A Acc Pg. A210-212

18V+18V LXT Lithium-Ion Cordless Grass Trimmer

BL MOTOR XPT ADT AFT

ADAPT TO

- METAL BLADE
- NYLON CUTTING HEAD
- PLASTIC BLADE

Offset handle
Enabling user to work with less fatigue even in long continuous operation and allowing for a wider swing.

BL Motor
Rear end mounted brushless motor makes the tool balance similar to engine grass trimmers

Reverse switch for clearing entangled weeds and grass from cutting head

Specifications:-

Cutting Width	Metal Blade: 255 mm Nylon Cutting Head: 430 mm Plastic Blade: 305 mm
No Load Speed (RPM)	Metal Blade (3 / 2 / 1): 0 - 7,000 / 0 - 5,500 / 0 - 4,600 Nylon Cutting Head (3 / 2 / 1): 0 - 5,500 / 0 - 5,000 / 0 - 4,600 Plastic Blade (305 mm) (3 / 2 / 1): 0 - 7,000 / 0 - 5,500 / 0 - 4,600 Plastic Blade (255 mm) (3 / 2 / 1): 0 - 5,500 / 0 - 5,000 / 0 - 4,600
Spindle Size	M10 x 1.25 LH
Vibration Level	Left / Right: 2.5 / 2.5 m/s ² or less
Dimensions (L x W x H)	1,846x628x530 mm
Net weight	6.3 kg

Standard Equipment: Safety Goggles, Hex Wrench

AVAILABLE VARIANTS		
5.0Ah	3.0Ah	"Z" VARIANT
		DUR369A Z TOOL ONLY (DOES NOT INCLUDE BATTERY / CHARGER)



DUR369N Acc Pg. A210-212

18V+18V LXT Lithium-Ion Cordless Grass Trimmer

BL MOTOR XPT ADT AFT

ADAPT TO

- NYLON CUTTING HEAD
- PLASTIC BLADE

Loop handle

BL Motor
Rear end mounted brushless motor makes the tool balance similar to engine grass trimmers

Reverse switch for clearing entangled weeds and grass from cutting head

Specifications:-

Cutting Width	Nylon Cutting Head: 430 mm Plastic Blade: 305 mm
No Load Speed (RPM)	Nylon Cutting Head (3 / 2 / 1): 0 - 5,000 / 0 - 4,600 / 0 - 4,000
Spindle Size	M10 x 1.25 LH
Vibration Level	Left / Right: 2.5 / 2.5 m/s ² or less
Dimensions (L x W x H)	1,834x226x301 mm
Net weight	6.1 kg

Standard Equipment: Safety Goggles, Hex Wrench

AVAILABLE VARIANTS		
5.0Ah	3.0Ah	"Z" VARIANT
		DUR369N Z TOOL ONLY (DOES NOT INCLUDE BATTERY / CHARGER)

- CORDLESS
- FIXING / FASTENING
- DRILLING / IMPACT DRILLING
- CONCRETE DRILLING / DEMOLITION
- CUTTING [CONCRETE / MASONRY / METAL]
- MULTI TOOL
- GRINDING
- SANDING / POLISHING
- SAWING
- ROUTERING / PLANING
- CLEANING
- HEAT GUN / LASERS
- PNEUMATIC TOOLS
- GARDEN TOOLS
- GENERATORS

CORDLESS
FIXING / FASTENING
DRILLING / IMPACT DRILLING
CONCRETE DRILLING / DEMOLITION
CUTTING [CONCRETE/ MASONRY/ METAL]
MULTI TOOL
GRINDING
SANDING / POLISHING
SAWING
ROUTERING / PLANING
CLEANING
HEAT GUN / LASERS
PNEUMATIC TOOLS
GARDEN TOOLS
GENERATORS

DUR364L

Acc Pg. A210-212

18V+18V LXT Lithium-Ion Cordless Grass Trimmer



BL Motor
Outer Rotor BL Motor provides high operating efficiency

Loop handle

Direct drive system
for more power, more speed and longer run time

Reverse switch
for clearing entangled weeds and grass from cutting head

Specifications:-

Cutting Width	Trimmer Head: 350 mm
No Load Speed (RPM)	High / Low: 6,500 / 5,000
Spindle Size	M8 x 1.25 RH
Vibration Level	Front / Rear: 2.5 / 2.5 m/s ² or less
Dimensions (L x W x H)	1,754x310x229 mm
Net weight	4.4 kg

Standard Equipment: Safety Goggles, Hex Wrench

AVAILABLE VARIANTS		
5.0Ah	3.0Ah	"Z" VARIANT
-	-	DUR364L Z TOOL ONLY (DOES NOT INCLUDE BATTERY / CHARGER)

DUP362

18V+18V LXT Lithium-Ion Cordless Pruning Shears



18V X2 (36V) LXT Li-Ion Battery Powered Pruning Shears

- Higher torque for increased cutting performance (DUP362)
- 18V solution for corded power demands
- Smooth cutting similar to that of a hand pruner
- Extra sharp, made-in-Japan forged blade

Specifications:-

Capacity	Max cutting : 33 mm Max blade opening : 54 mm
Cutting Torque	250 N
Sound Pressure Level	70 dB(A) or less
Vibration Level	2.5 m/s ² or less
Dimensions (L x W x H)	305x43x106 mm
Net weight	0.8 kg

Standard Equipment: Wrench set, Holster, Harness, Arm Band

AVAILABLE VARIANTS		
5.0Ah	3.0Ah	"Z" VARIANT
-	-	DUP362 Z TOOL ONLY (DOES NOT INCLUDE BATTERY / CHARGER)

DUB363

Acc Pg. A213

18V+18V LXT Lithium-Ion Cordless Blower + Vacuum



18V X2 (36V) LXT Li-Ion Cordless 2-Speed Blower + Vacuum function (can be used as a vacuum with a dust bag). Incredibly high power over 25mL engine blower

- Variable trigger switch + Cruise control lever allows you to lock the variable speed control trigger at the desired power level.
- Mulching function: A shredding blade cuts sucked fallen leaves into fine mulch
- 3-stage telescopic long nozzle with adjustment range of 100mm

Runtime*
30-75 min Vacuuming: Mode: 1
Battery: BL1860B x2
9.5-75 min Blowing: Mode: 2-1
Battery: BL1860B x2

Specifications:-

Max Air Volume	13.4 m ³ /min (Blower) / 12.7 m ³ /min (Vacuum)
Max Air Velocity	3.2kPa (Blower)
Max sealed suction	65 m/s (Vacuum)
No Load Speed (RPM)	0 - 7,850
Vibration level	0.8m/s ²
Sound power level	96dB(A)
Dimensions (L x W x H)	w/ 3-Stage Telescopic Long Nozzle: 737/786/836x200x415 mm
Net weight	6.6 kg

Standard Equipment: Nozzle, Vacuum Kit, Shoulder belt. *Continuous run time (approx.) min

AVAILABLE VARIANTS		
5.0Ah	3.0Ah	"Z" VARIANT
-	-	DUB363 ZV TOOL + VACUUM KIT (DOES NOT INCLUDE BATTERY / CHARGER)



DUB362

Acc Pg. A213

18V+18V LXT Lithium-Ion Cordless Blower



18V X2 (36V) LXT BL Brushless Cordless Variable 6-Speed Blower

- Powerful cordless blower: Amazing 54 m/s & 13.4 m³/min operation
- 6-Stage air velocity/volume selection dial with variable speed control trigger
- 3-Stage telescopic long nozzle with adjustment range of 100 mm for user convenience



Lock-on button operable from both side

6-stage air volume/velocity selection just by adjusting dial

3-stage telescopic long nozzle with an adjustment range of 100mm (4")



Reduced noise level

3 blade fan to reduce noise level without losing air volume and velocity

Double housing structure to minimize the noise level

Additional sponge inside the housing to absorb the noise level

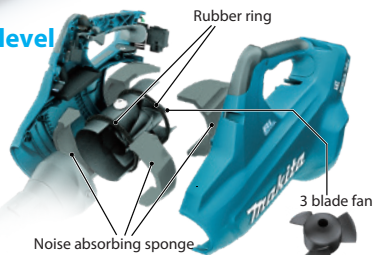

Hole on the bottom of housing for hanging the machine



Dual battery fuel gauge Indicates the power remaining in each battery individually in 3 LED stages.



Shoulder belt

Runtime*
13-90
min
BL1860B x2

Continuous run time (approx) (High to Low)

Specifications:-



Air volume	6.9-13.4m ³ /min
Air speed	27-54m/s
No load speed (rpm)	11,400-21,500
Sound power level	96dB(A)
Vibration level	0.3m/s ²
Dimensions (L x W x H)	830-930x205x295mm
Net weight	3.5kg

Standard Equipment: Nozzle, Shoulder belt.

AVAILABLE VARIANTS

5.0Ah	3.0Ah	"Z" VARIANT
-	-	DUB362 Z TOOL ONLY (DOES NOT INCLUDE BATTERY / CHARGER)

DUB361

Acc Pg. A213 **430**

18V+18V LXT Lithium-Ion Cordless Blower



18V X2 (36V) LXT Li-Ion Cordless 2-Speed Blower

- Makita-built motor produces a maximum air velocity of 93 m/s
- Compact and lightweight for single handed operation
- Push button air volume selection (High / Low settings)

Runtime*
36-110
min
BL1860B x2

Continuous run time (approx) (High to Low)

Specifications:-



*No load continuous run time (approx) : min

Air volume	Hi: 4.4m ³ /min / Lo: 2.3m ³ /min
Air speed	Hi: 93m/s / Lo: 57m/s
No load speed (rpm)	Hi: 17,000 / Lo: 10,000
Sound pressure level	82.3dB(A)
Sound power level	94.7dB(A)
Dimensions (L x W x H)	905 x 141 x 194mm
Net weight	2.6kg

Standard Equipment: Nozzle, Shoulder belt.

AVAILABLE VARIANTS

5.0Ah	3.0Ah	"Z" VARIANT
-	-	DUB361 Z TOOL ONLY (DOES NOT INCLUDE BATTERY / CHARGER)



CORDLESS

FIXING / FASTENING

DRILLING / IMPACT DRILLING

CONCRETE DRILLING / DEMOLITION

CUTTING [CONCRETE / MASONRY / METAL]

MULTI TOOL

GRINDING

SANDING / POLISHING

SAWING

ROUTERING / PLANING

CLEANING

HEAT GUN / LASERS

PNEUMATIC TOOLS

GARDEN TOOLS

GENERATORS

- CORDLESS
- FIXING / FASTENING
- DRILLING / IMPACT DRILLING
- CONCRETE DRILLING / DEMOLITION
- CUTTING [CONCRETE/ MASONRY/ METAL]
- MULTI TOOL
- GRINDING
- SANDING / POLISHING
- SAWING
- ROUTERING / PLANING
- CLEANING
- HEAT GUN / LASERS
- PNEUMATIC TOOLS
- GARDEN TOOLS
- GENERATORS



Model	Deck	Self-Propelled	BL MOTOR	Battery slots	Cutting / Collecting / Mulching	Rear discharge	Side discharge
DLM533	Aluminum	✓	✓	4	✓	✓	
DLM532	Steel	✓	✓	4	✓		✓
DLM531	Steel		✓	4	✓		✓
DLM460	Steel		✓	2	✓		
DLM431	Plastic			2	✓*		
DLM382	Plastic			2	✓*		

* Optional accessory for Mulching (DLM431 / DLM382)

DLM533 (Aluminium Deck | Self Propelled | Rear Discharge) Acc Pg. A212

18V+18V LXT Cordless Lawn Mower with 4 battery slots



18vx2 534mm Cordless Lawn Mower with better usability.

- 3 in 1 (Cutting, Collecting, Mulching)
- Grass box with grass level indicator
- Single-lever cutting height adjustment
- Built-in ball bearing on axles for added durability
- Child lock key
- 2-speed mode
- IPX4 : water resistant

Runtime
40min
BL1860B x4

2,300 m²
Recommended mowing area
BL1860B x2

Specifications:-

Cutting Width	534 mm
Cutting Height	20 - 100 mm
No. of stages	10 stages
No Load Speed (RPM)	2,300 - 2,800
Propelling speed	2.5 - 5.0 km/h
Grass box capacity	70L
Dimensions (L x W x H)	1,655-1,740x590x990-1,100 mm
Net weight	47.9 kg

Standard Equipment: Socket wrench

AVAILABLE VARIANTS		
5.0Ah	3.0Ah	"Z" VARIANT
-	-	DLM533 Z TOOL ONLY (DOES NOT INCLUDE BATTERY / CHARGER)

DLM532 (Steel Deck | Self Propelled | Side Discharge) Acc Pg. A212

18V+18V LXT Cordless Lawn Mower with 4 battery slots



18vx2 534mm Cordless Lawn Mower with better usability.

- Optimum blade design for less rotational speed reduction of the blade
- Enhanced rigidity of handle
- Grass box with grass level indicator
- Single-lever cutting height adjustment
- Built-in ball bearing on axles for added durability
- Child lock key
- 2-speed mode

Runtime
40min
BL1860B x4

2,300 m²
Recommended mowing area
BL1860B x2

Specifications:-

Cutting Width	534 mm
Cutting Height	20 - 100 mm
No. of stages	10 stages
No Load Speed (RPM)	2,300 - 2,800
Propelling speed	2.5 - 5.0 km/h
Grass box capacity	70L
Dimensions (L x W x H)	1,630-1,715x590x990-1,095 mm
Net weight	42.9 kg

Standard Equipment: Side Discharge, Socket wrench

AVAILABLE VARIANTS		
5.0Ah	3.0Ah	"Z" VARIANT
-	-	DLM532 Z TOOL ONLY (DOES NOT INCLUDE BATTERY / CHARGER)

DLM531 (Steel Deck | Push Type | Side Discharge) Acc Pg. A212

18V+18V LXT Cordless Lawn Mower with 4 battery slots



18vx2 534mm Cordless Lawn Mower with better usability.

- Optimum blade design for less rotational speed reduction of the blade
- Enhanced rigidity of handle
- Grass box with grass level indicator
- Single-lever cutting height adjustment
- Built-in ball bearing on axles for added durability
- Child lock key
- 2-speed mode
- Large grass discharge port

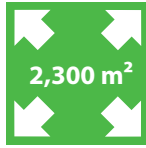

Runtime
50min
BL1860B x4

Specifications:-

Cutting Width	534 mm
Cutting Height	20 - 100 mm
No. of stages	10 stages
No Load Speed (RPM)	2,300 - 2,800
Propelling speed	2.5 - 5.0 km/h
Grass box capacity	70L
Dimensions (L x W x H)	1,630-1,715x590x990-1,095 mm
Net weight	38.3 kg

Standard Equipment: Side Discharge, Socket wrench

AVAILABLE VARIANTS		
5.0Ah	3.0Ah	"Z" VARIANT
-	-	DLM531 Z TOOL ONLY (DOES NOT INCLUDE BATTERY / CHARGER)

DLM460 (Steel Deck | Push Type) Acc Pg. A212

18V+18V LXT Cordless Lawn Mower



18vx2 460mm Cordless Lawn Mower with better usability.

- 3 in 1 (Cutting, Collecting, Mulching)
- Grass box with grass level indicator
- Single-lever cutting height adjustment
- Built-in ball bearing on axles for added durability
- Child lock key
- 2-speed mode
- IPX4 : water resistant



Runtime
21min
BL1860B x2

Specifications:-

Cutting Width	460 mm
Cutting Height	20 - 75 mm
No Load Speed (RPM)	2,500 - 3,300
Grass box capacity	45L
Dimensions (L x W x H)	1,319-1,518x532x879-1,138 mm
Net weight	27.6 kg

Standard Equipment: Socket wrench

AVAILABLE VARIANTS		
5.0Ah	3.0Ah	"Z" VARIANT
-	-	DLM460 Z TOOL ONLY (DOES NOT INCLUDE BATTERY / CHARGER)

DLM431 (Plastic Deck | Push Type) Acc Pg. A212

18V+18V LXT Cordless Lawn Mower



18vx2 430mm Cordless Lawn Mower with better usability.

- Grass box with grass level indicator
- Single-lever cutting height adjustment
- Built-in ball bearing on axles for added durability
- Child lock key
- 2-speed mode



Runtime
30min
BL1850B x2

Specifications:-

Cutting width	430mm (17")
Cutting height	20-75mm
No load speed (rpm)	3,600
Grass box capacity	50L
Dimensions (L x W x H)	1,450x460x950mm
Net weight	18.0kg

Standard Equipment: Socket wrench,

AVAILABLE VARIANTS		
5.0Ah	3.0Ah	"Z" VARIANT
DLM431 PT2 INCLUDES 2 BATTERIES / 1 TWO PORT CHARGER	-	DLM431 Z TOOL ONLY (DOES NOT INCLUDE BATTERY / CHARGER)

DLM382 (Plastic Deck | Push Type) Acc Pg. A212

18V+18V LXT Cordless Lawn Mower



18vx2 380mm Cordless Lawn Mower with better usability.

- Grass box with grass level indicator
- Single-lever cutting height adjustment
- Easy installation and removal of the grass box
- Child lock key
- Single speed mode



Runtime
35min
BL1860B x2

Specifications:-

Cutting Width	380 mm
Cutting Height	20 - 75 mm
No. of stages	13 stages
No Load Speed (RPM)	3,700
Grass box capacity	40L
Dimensions (L x W x H)	1,380-1,410x450x985-1,005 mm
Net weight	16.9 kg

Standard Equipment: Socket wrench

AVAILABLE VARIANTS		
5.0Ah	3.0Ah	"Z" VARIANT
-	-	DLM382 Z TOOL ONLY (DOES NOT INCLUDE BATTERY / CHARGER)

- CORDLESS
- FIXING / FASTENING
- DRILLING / IMPACT DRILLING
- CONCRETE DRILLING / DEMOLITION
- CUTTING [CONCRETE/ MASONRY/ METAL]
- MULTI TOOL
- GRINDING
- SANDING / POLISHING
- SAWING
- ROUTERING / PLANING
- CLEANING
- HEAT GUN / LASERS
- PNEUMATIC TOOLS
- GARDEN TOOLS
- GENERATORS

CORDLESS
FIXING / FASTENING
DRILLING / IMPACT DRILLING
CONCRETE DRILLING / DEMOLITION
CUTTING (CONCRETE/ MASONRY/ METAL)
MULTI TOOL
GRINDING
SANDING / POLISHING
SAWING
ROUTERING / PLANING
CLEANING
HEAT GUN / LASERS
PNEUMATIC TOOLS
GARDEN TOOLS
GENERATORS

DCE090 230mm

18V+18V LXT - Lithium-Ion Cordless Power Cutter



Water supply kit can be connected. The hose is designed to run inside the tool housing to prevent from being caught in objects.

Compact / Light Weight / Low Nose / High Power Power Cutter

- Max. cutting capacity 88mm depth
- AFT (Active Feedback sensing Technology) prevents kickback
- Overload indicator lamp
- Low vibration for increased operator convenience
- Ideal for cutting concrete slabs, walls, pavers, or block.



Battery cover
Protects battery from water in wet cutting

Electric brake system
After the switch trigger is released:
• Diamond wheel stops in approximately 4.0 seconds
• Cut-off wheel stops in approximately 2.0 seconds

Accessories (Optional)



230mm Diamond wheel
Part No. E-02967
Size: 230 x 3.2 x 22.23mm



230mm Vacuum Brazed Diamond Wheel (Rescue)
Part No. B-55326
Size: 230 x 3.1 x 22.23mm



230mm Abrasive Cut-off Wheel
Part No. D-18792
Size: 230 x 2.0 x 22.23mm



Specifications:-

Wheel Diameter	230 mm (9")
Wheel Hole Diameter	22.23 mm
Max Wheel Thickness	3.0 mm
Max Cutting Capacity	88 mm
No Load Speed (RPM)	6,600
Vibration Level	Left / Right: 5.9 / 4.0 m/s ²
Sound Pressure Level	103 dB(A)
Sound Power Level	114 dB(A)
Dimensions (L x W x H)	554x241x283 mm
Net weight	6.3 kg

Standard Equipment: Hex Wrench

AVAILABLE VARIANTS		
5.0Ah	3.0Ah	"Z" VARIANT
DCE090 P2 INCLUDES 2 BATTERIES / 1 TWO PORT CHARGER	-	DCE090 Z TOOL ONLY (DOES NOT INCLUDE BATTERY / CHARGER)

DHR400N 40mm (Adapted for SDS-MAX bits) Acc Pg. A065

18V+18V LXT - Lithium-Ion Cordless Rotary Hammer

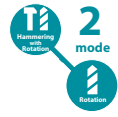

AWS BL XPT AVT & SOFT NO LOAD AFT

SDS-MAX Rotary hammer - Powered by two 18V Li-ion batteries

- Excellent performance equivalent to AC Model
- BL Motor & AVT + SOFT NO LOAD Functions Deliver High Power and Low Vibration
- 2 Mode operation - Hammering with rotation and Rotation only
- With auto wireless system

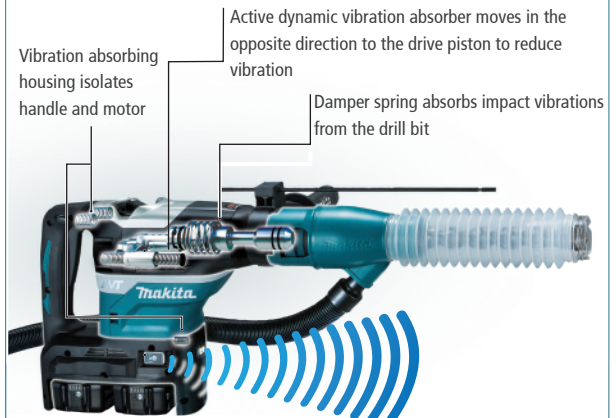

AFT - Smart function to minimize the danger of kick-back

AFT function shuts down the tool, if the rotation speed suddenly slows down

AFT



Specifications:-

Impact Energy	11.4 J
Capacity	Concrete (w/ T.C.T. bit) : 40 mm Concrete (w/ Core bit) : 105 mm
Blows Per Minute (BPM)	1,450 - 2,900
No Load Speed (RPM)	250 - 500
Sound Pressure Level	91 dB(A)
Sound Power Level	102 dB(A)
Vibration Level	Hammer Drilling Into Concrete: 5.0 m/s ²
Dimensions(L x W x H)	473x120x285 mm
Net weight	8.1kg

Standard Equipment: Side Handle, Depth Gauge

AVAILABLE VARIANTS		
5.0Ah	3.0Ah	"Z" VARIANT
-	-	DHR400N ZKU TOOL ONLY - WITH CARRY CASE AND BLUETOOTH CHIP (DOES NOT INCLUDE BATTERY / CHARGER)

DHR283 28mm (Adapted for SDS-PLUS bits) Acc Pg. A061

18V+18V LXT - Lithium-Ion Cordless Combination Hammer



SDS-PLUS Combination hammer - Powered by two 18V Li-ion batteries

- BL Motor & AVT + SOFT NO LOAD Functions Deliver High Power and Low Vibration
- 3 Mode operation - Rotation only, Hammering with rotation and Hammering only
- Active Feedback sensing Technology (AFT) turns the motor off if bit rotation is suddenly forced to stop
- With auto wireless system



AFT - Smart function to minimize the danger of kick-back
 AFT function shuts down the tool, if the rotation speed suddenly slows down



Specifications:-

Impact Energy	3.2 J
Capacity	Concrete / Steel / Wood / Core Bit / Diamond Core Bit (Dry Type): 28 / 13 / 32 / 54 / 65 mm
Blows Per Minute (BPM)	0 - 5,000
No Load Speed (RPM)	0 - 980
Vibration Level	Hammer Drilling into Concrete: 9.5 m/s ² Drilling Into Metal: 2.5 m/s ²
Sound Pressure Level	92 dB(A)
Sound Power Level	103 dB(A)
Dimensions (L x W x H)	404x134x232 mm
Net weight	5.1 kg

Standard Equipment: Depth Gauge, Side Grip, Quick change drill chuck

AVAILABLE VARIANTS		
5.0Ah	3.0Ah	"Z" VARIANT
-	-	DHR283 ZJ TOOL ONLY - WITH MAKPAC CASE (DOES NOT INCLUDE BATTERY / CHARGER / BLUETOOTH CHIP)

DHR281 28mm (Adapted for SDS-PLUS bits) Acc Pg. A061

18V+18V LXT - Lithium-Ion Cordless Combination Hammer



SDS-PLUS Combination hammer - Powered by two 18V Li-ion batteries

- BL Motor & AVT + SOFT NO LOAD Functions Deliver High Power and Low Vibration
- 3 Mode operation - Rotation only, Hammering with rotation and Hammering only

Specifications:-

Impact Energy	3.2 J
Capacity	Concrete / Steel / Wood / Core Bit / Diamond Core Bit (Dry Type): 28 / 13 / 32 / 54 / 65 mm
Blows Per Minute (BPM)	0 - 5,000
No Load Speed (RPM)	0 - 980
Vibration Level	Hammer Drilling into Concrete: 9.5 m/s ² Drilling Into Metal: 2.5 m/s ²
Sound Pressure Level	92 dB(A)
Sound Power Level	103 dB(A)
Dimensions (L x W x H)	404x134x232 mm
Net weight	5.1 kg

Standard Equipment: Depth Gauge, Side Grip, Quick change drill chuck

AVAILABLE VARIANTS		
5.0Ah	3.0Ah	"Z" VARIANT
DHR281 PT2J INCLUDES 2 BATTERIES / 1 TWO PORT CHARGER AND MAKPAC CASE	-	DHR281 ZJ TOOL ONLY - WITH MAKPAC CASE (DOES NOT INCLUDE BATTERY / CHARGER)

DHR280 28mm (Adapted for SDS-PLUS bits) Acc Pg. A061

18V+18V LXT - Lithium-Ion Cordless Combination Hammer



SDS-PLUS Combination hammer - Powered by two 18V Li-ion batteries

- BL Motor & AVT + SOFT NO LOAD Functions Deliver High Power and Low Vibration
- 3 Mode operation - Rotation only, Hammering with rotation and Hammering only

Specifications:-

Impact Energy	3.2 J
Capacity	Concrete / Steel / Wood / Core Bit / Diamond Core Bit (Dry Type): 28 / 13 / 32 / 54 / 65 mm
Blows Per Minute (BPM)	0 - 5,000
No Load Speed (RPM)	0 - 980
Vibration Level	Hammer Drilling into Concrete: 9.5 m/s ² Drilling Into Metal: 2.5 m/s ²
Sound Pressure Level	92 dB(A)
Sound Power Level	103 dB(A)
Dimensions (L x W x H)	404x134x232 mm
Net weight	4.9 kg

Standard Equipment: Depth Gauge, Side Grip

AVAILABLE VARIANTS		
5.0Ah	3.0Ah	"Z" VARIANT
DHR280 PT2J INCLUDES 2 BATTERIES / 1 TWO PORT CHARGER AND MAKPAC CASE	-	DHR280 ZJ TOOL ONLY - WITH MAKPAC CASE (DOES NOT INCLUDE BATTERY / CHARGER)

CORDLESS

FIXING / FASTENING

DRILLING / IMPACT DRILLING

CONCRETE DRILLING / DEMOLITION

CUTTING [CONCRETE/ MASONRY/ METAL]

MULTI TOOL

GRINDING

SANDING / POLISHING

SAWING

ROUTERING / PLANING

CLEANING

HEAT GUN / LASERS

PNEUMATIC TOOLS

GARDEN TOOLS

GENERATORS

- CORDLESS
- FIXING / FASTENING
- DRILLING / IMPACT DRILLING
- CONCRETE DRILLING / DEMOLITION
- CUTTING [CONCRETE/ MASONRY/ METAL]
- MULTI TOOL
- GRINDING
- SANDING / POLISHING
- SAWING
- ROUTERING / PLANING
- CLEANING
- HEAT GUN / LASERS
- PNEUMATIC TOOLS
- GARDEN TOOLS
- GENERATORS

DHR263 26mm (Adapted for SDS-PLUS bits) Acc Pg. A061 **442** W

18V+18V LXT - Lithium-Ion Cordless Combination Hammer



XPT

Combination hammer - Powered by two 18V Li-ion batteries

- Vibration absorbing handle provides comfortable operation
- 3 Mode operation - Rotation only, Hammering with rotation and Hammering only
- Ergonomic soft grip handle and large 2-finger trigger provide increased comfort on the job

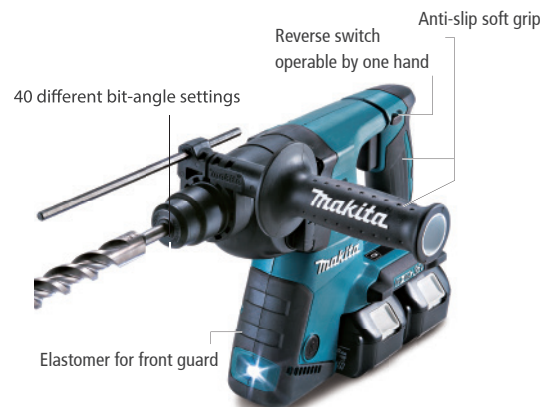

Specifications:-

Impact Energy	3.0 J
Capacity	Concrete / Steel / Wood: 26 / 13 / 32 mm
Blows Per Minute (BPM)	0 - 5,000
No Load Speed (RPM)	0 - 1,250
Vibration Level	Hammer Drilling Into Concrete: 15.5 m/s ² Drilling Into Metal: 5.0 m/s ²
Sound Pressure Level	94 dB(A)
Sound Power Level	105 dB(A)
Dimensions (L x W x H)	374x116x232 mm
Net weight	5.1 kg

Standard Equipment: Depth Gauge , Side Grip.

AVAILABLE VARIANTS		
5.0Ah	3.0Ah	"Z" VARIANT
-	DHR263 RF2 INCLUDES 2 BATTERIES / 1 CHARGER AND CARRY CASE	DHR263 Z TOOL ONLY (DOES NOT INCLUDE BATTERY / CHARGER)

Dust extraction System

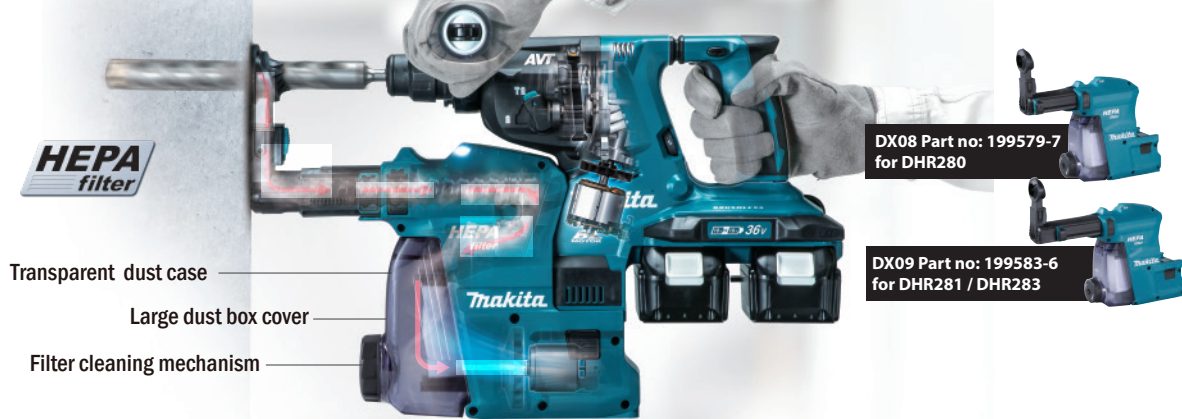

MODEL	CAPACITY	SHANK	CHUCK TYPE	BL MOTOR	AVT	SOFT NO LOAD	AFT	XPT	DUST EXTRACTOR
DHR400	40mm	SDS-MAX		✓	✓	✓	✓	✓	-
DHR280	28mm	SDS-PLUS	Normal chuck	✓	✓	✓	✗	✓	DX08
DHR281	28mm	SDS-PLUS	Quick change drill chuck	✓	✓	✓	✗	✓	DX09
DHR283	28mm	SDS-PLUS	Quick change drill chuck	✓	✓	✓	✓	✓	DX09
DHR263	26mm	SDS-PLUS	Normal chuck	✗	✗	✗	✗	✓	-

DDA460 13mm
Acc Pg. A037

18V+18V LXT - Lithium-Ion Cordless Angle Drill



BL MOTOR ADT XPT

High Power Angle Drill - Powered by two 18V Li-ion batteries



Exceptional high power and high speed achieved with BL Motor

Excellent maneuverability

Well-balanced
Optimum weight balance



Rotation handle

Torque limiter
When the drill bit is locked, rotation will stop the bit

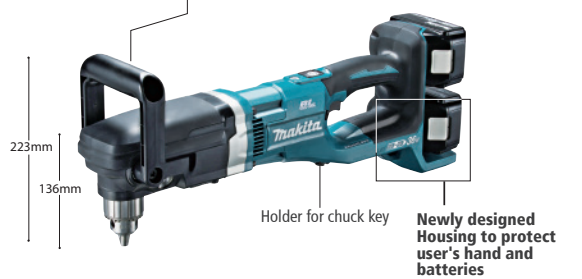
Side handle
Pressing Side handle against pillar provides stable work



Holder for chuck key Newly designed Housing to protect user's hand and batteries

Specifications:-

Capacity	Steel: 13 mm Wood (Self-feed bit) : 118 mm Wood (Hole saw) : 159 mm
No Load Speed (RPM)	High / Low: 0 - 1,400 / 0 - 350
Vibration Level	Drilling Into Metal: 2.5 m/s ² or less
Dimensions (L x W x H)	538x128x223mm
Net weight	6.4 kg

Standard Equipment: Chuck Key, Hex Wrench, Side Grip

AVAILABLE VARIANTS

5.0Ah	3.0Ah	"Z" VARIANT
DDA460 PT2 INCLUDES 2 BATTERIES / 1 TWO PORT CHARGER AND CARRY CASE	-	DDA460 ZK TOOL ONLY (WITH CARRY CASE) (DOES NOT INCLUDE BATTERY / CHARGER)

DDG460

18V+18V LXT - Lithium-Ion Cordless Earth Auger



BL MOTOR ADT XPT

High Power Earth Auger - Powered by two 18V Li-ion batteries



Exceptional high power and high speed achieved with BL Motor

Reversing switch
enables to extract, in reverse rotation mode, an auger bit jammed in soil with high resistance like clay soil

Torque limiter
When the drill bit is locked, rotation will stop the bit

Side handle
includes a bar which receives reaction force and an auxiliary handle, and helps the user drill holes in the ground easier
Part No. 191P11-3

Reaction receiver

Pin
Part No. E-07331

Adapter



For larger holes



Earth auger drill bit
Length: 800mm

⌀100 mm Part No. E-07294

⌀150 mm Part No. E-07303

⌀200 mm Part No. E-07319

Extension bar
540 mm
Part No. E-07325

Blade for earth auger bit
Changing blade for Earth auger drill bit

For 100mm Part No. E-07630
150mm E-07646
200mm E-07652

Specifications:-

Capacity	Sandy Soil: 200 mm Clay Soil: 150 mm
No Load Speed (RPM)	High / Low: 0 - 1,400 / 0 - 350
Max Fastening Torque	High: 48 N-m Low: 136 N-m
Vibration Level	2.5 m/s ² or less
Dimensions (L x W x H)	840 x 607 x 223 mm
Net weight	8.2 kg

Standard Equipment: Chuck Key, Hex Wrench, Adapter

AVAILABLE VARIANTS

5.0Ah	3.0Ah	"Z" VARIANT
DDG460 T2 INCLUDES 2 BATTERIES / 1 TWO PORT CHARGER AND CARRY CASE	-	DDG460 Z TOOL ONLY (DOES NOT INCLUDE BATTERY / CHARGER)

CORDLESS	
FIXING / FASTENING	
DRILLING / IMPACT DRILLING	
CONCRETE DRILLING / DEMOLITION	
CUTTING [CONCRETE/ MASONRY/ METAL]	
MULTI TOOL	
GRINDING	
SANDING / POLISHING	
SAWING	
ROUTERING / PLANING	
CLEANING	
HEAT GUN / LASERS	
PNEUMATIC TOOLS	
GARDEN TOOLS	
GENERATORS	

CORDLESS
FIXING / FASTENING
DRILLING / IMPACT DRILLING
CONCRETE DRILLING / DEMOLITION
CUTTING [CONCRETE/ MASONRY/ METAL]
MULTI TOOL
GRINDING
SANDING / POLISHING
SAWING
ROUTERING / PLANING
CLEANING
HEAT GUN / LASERS
PNEUMATIC TOOLS
GARDEN TOOLS
GENERATORS

DWT310

18V+18V LXT - Lithium-Ion Cordless Shear Wrench



Max Fastening Torque Over
800N.m

High-speed fastening beyond AC tool

- Fastens 380 M22 (7/8") torque shear bolts with two 18V 6.0 Ah batteries



High Power and High Torque

Fatigue-reducing items



Shoulder belt (optional)
(for carrying)



Transport hook (optional)



Shoulder belt & hook: Don't use them as fall prevention devices



Specifications:-

Capacity	Bolt : M16, M20, M22 (5/8", 3/4", 7/8")
No Load Speed (RPM)	14
Max Fastening Torque	804 N m (593 ft.lbs.)
Vibration Level	2.5 m/s ² or less
Sound Pressure Level	83 dB(A)
Sound Power Level	94 dB(A)
Dimensions (L x W x H)	296x130x377 mm
Net weight	7.1 kg

Standard Equipment: Screwdriver

AVAILABLE VARIANTS		
5.0Ah	3.0Ah	"Z" VARIANT
DWT310 PT2 INCLUDES 2 BATTERIES / 1 TWO PORT CHARGER AND CARRY CASE	-	DWT310 ZK TOOL ONLY (WITH CARRY CASE) (DOES NOT INCLUDE BATTERY / CHARGER)

DLW140 - 355mm

Acc Pg. A082-083

18V+18V LXT - Lithium-Ion Cordless Portable Cut-off



Cutting work Amount
130cuts
75 x 45mm, T: 0.8mm metal stud BL1850B x2

World's First Cordless Portable Cut-off

- Fastens 380 M22 (7/8") torque shear bolts with two 18V 6.0 Ah batteries



High Power and High Speed

Load status indicator



As the motor load increases, the lighting lamp increases.

Toolless replacement of abrasive cut-off wheel



Carry handle
for easy transport to job site



Large spark guard



Toolless adjustment of guide plate



allows for easy adjustment of the guide plate by simple handling

- 3 stage position change
- 0 to 45 degree angle adjustment

Saw head locking by pin lock



makes it easy to lock down the saw head for storage and transport.

Specifications:-

Wheel Diameter	355 mm (14")
Hole Diameter	25.4 mm (1")
No Load Speed (RPM)	3,800
Capacity at 90°	Round: 127 mm (5") Rectangular: 115x130 mm / Rectangular: 102x194 mm
Capacity at 45°	Round: 127 mm (5") / Rectangular: 115x103 mm
Vibration Level	2.5 m/s ²
Sound Pressure Level	103 dB(A)
Sound Power Level	115 dB(A)
Dimensions (L x W x H)	537x290x640 mm
Net weight	17.8 kg

Standard Equipment: Screwdriver

AVAILABLE VARIANTS		
6.0Ah	3.0Ah	"Z" VARIANT
DLW140 PG2 INCLUDES 2 BATTERIES / 1 TWO PORT CHARGER ONLY	-	DLW140 Z TOOL ONLY (DOES NOT INCLUDE BATTERY / CHARGER)

DGA700 180mm | DGA701 180mm | DGA900 230mm | DGA901 230mm

Acc Pg. A112-128

18V+18V LXT - Lithium-Ion Cordless Angle Grinder

BL MOTOR **ADT AFT** (BRAKE) **XPT** **AWS** (AUTO WIRELESS SYSTEM ONLY FOR DGA701 / DGA901)



BL MOTOR
Faster Cutting with High power / High torque brushless motor

Anti-vibration rubber
provides less vibration, allowing comfortable operation

Ergonomically designed Battery indicator handle with soft grip

Over-Discharge protection
Overheat protection

Battery guard



Electric brake
Electric brake is activated after the tool is switched off.

Large switch lever
with lock-off function (without lock-on function)
Lock-off function prevents the switch lever from being accidentally pulled.

Anti-restart function
The motor does not start up if battery is inserted when the switch slid to "on".

Better gravity balance
High maneuverability in any angle since it is possible to grab the center of gravity

ADT

Automatic torque Drive Technology
automatically changes the cutting speed according to load conditions for an optimum operation:
• On light duty: high-speed rotation mode
• On heavy duty: high torque mode

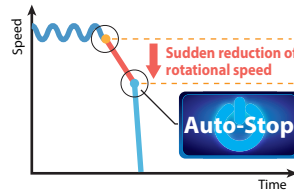
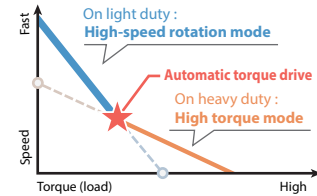

AFT

Active Feedback sensing Technology
Shuts down the tool, if the rotation speed suddenly slows down.

Optional Dust collecting wheel guard

Connects the Grinders with the Vacuum Cleaner

For DGA900 & AC 230mm Angle Grinders only Max cutting depth: 60mm

With single notch on Bearing box type
Part no. 198380-7

(Use with Inner flange 45cc Part No. 198675-8)



Plunge cutting can be done without lifting Base



Specifications:-	DGA700	DGA701	DGA900	DGA901
Wheel Diameter	180 mm (7")	180 mm (7")	230 mm (9")	230 mm (9")
No Load Speed (RPM)	7,800	7,800	6,000	6,000
Vibration Level: Surface Grinding	7.5 m/s ²	7.5 m/s ²	7.5 m/s ²	7.5 m/s ²
Disc Sanding	2.5 m/s ² or less	2.5 m/s ² or less	2.5 m/s ² or less	2.5 m/s ² or less
Sound Pressure Level	88 dB(A)	88 dB(A)	88 dB(A)	88 dB(A)
Sound Power Level	99 dB(A)	99 dB(A)	99 dB(A)	99 dB(A)
Dimensions (L x W x H)	499x200x158 mm	499x200x158 mm	499x250x158 mm	499x250x158 mm
Net weight	6.0 kg	6.0 kg	8.0 kg	8.0 kg
BL motor	✓	✓	✓	✓
ADT & AFT	✓	✓	✓	✓
XPT	✓	✓	✓	✓
AWS	✗	✓	✗	✓

Standard Equipment: Wheel Cover, Side Grip, Lock Nut Wrench

AVAILABLE VARIANTS

5.0Ah	3.0Ah	"Z" VARIANT
-	-	DGA700 ZK TOOL ONLY (WITH PLASTIC CARRY CASE) (DOES NOT INCLUDE BATTERY / CHARGER)
DGA701 TZU1 INCLUDES 2 BATTERIES + 2PORT CHARGER + BLUETOOTH CHIP + PLASTIC CARRY CASE	-	DGA701 ZKU TOOL ONLY (WITH PLASTIC CARRY CASE + BLUETOOTH CHIP) (DOES NOT INCLUDE BATTERY / CHARGER)
-	-	DGA900 ZK TOOL ONLY (WITH CARRY CASE) (DOES NOT INCLUDE BATTERY / CHARGER)
DGA901 TZU1 INCLUDES 2 BATTERIES + 2PORT CHARGER + BLUETOOTH CHIP + PLASTIC CARRY CASE	-	DGA901 ZKU1 TOOL ONLY (WITH PLASTIC CARRY CASE + BLUETOOTH CHIP) (DOES NOT INCLUDE BATTERY / CHARGER)

CORDLESS

FIXING / FASTENING

DRILLING / IMPACT DRILLING

CONCRETE DRILLING / DEMOLITION

CUTTING [CONCRETE/ MASONRY/ METAL]

MULTI TOOL

GRINDING

SANDING / POLISHING

SAWING

ROUTERING / PLANING

CLEANING

HEAT GUN / LASERS

PNEUMATIC TOOLS

GARDEN TOOLS

GENERATORS

CORDLESS
FIXING / FASTENING
DRILLING / IMPACT DRILLING
CONCRETE DRILLING / DEMOLITION
CUTTING [CONCRETE/ MASONRY/ METAL]
MULTI TOOL
GRINDING
SANDING / POLISHING
SAWING
ROUTERING / PLANING
CLEANING
HEAT GUN / LASERS
PNEUMATIC TOOLS
GARDEN TOOLS
GENERATORS

DSP600 165mm | DSP601 165mm

Acc Pg. A143-160

18V+18V LXT - Lithium-Ion Cordless Plunge Cut Saw



Dust management

Can be attached with a vacuum cleaner

Precision Bevel Cut

The position of cutting line is always the same regardless of bevel angle in cutting with Guide Rail attached.

Close-to-Wall Cutting

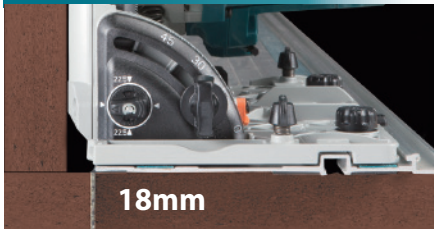

18mm

Only 18mm (away from wall at minimum)

Bevel Cut

Bevel Range
:: -1 to 48 degrees

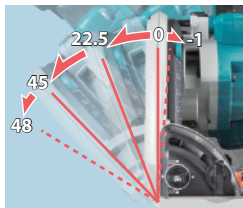

Depth Stopper for Splinter-free Cutting

Enables to easily cut a preliminary groove at a depth of 2mm for splinter-free cuts.



Tipover-Resistant Design



Slide lever prevents this tool from falling off the rail

Tool be sold along with guide Rail

Guide Rail 1.4 m: 194368-5
3.0 m: 194367-7



Specifications:-



	DSP600	DSP601
Wheel Diameter	165 mm	165 mm
Max Cutting Capacity	90°: 56 mm 45°: 40 mm 48°: 38 mm	90°: 56 mm 45°: 40 mm 48°: 38 mm
No Load Speed (RPM)	2,500 - 6,300	2,500 - 6,300
Dimensions (L x W x H)	346x241x272 mm	346x241x272 mm
Net weight	5.1 kg	5.1 kg
AWS	X	✓

Standard Equipment: Hex Wrench

	5.0Ah	3.0Ah	"Z" VARIANT
			DSP600 Z TOOL ONLY (DOES NOT INCLUDE BATTERY / CHARGER OR CARRY CASE)
			DSP601 Z TOOL ONLY (WITH BLUETOOTH CHIP) (DOES NOT INCLUDE BATTERY / CHARGER OR CARRY CASE)

Saw Blades for Plunge Cut Circular Saws



Specialized for cordless tools

Blade Dia (mm)	(Bore) Hole dia. (mm)	(Kerf) Tip Thickness (mm)	Plate (mm)	Hook Angle (deg)	No. of teeth	Tooth Shape	Application	Part No.
165	20	1.45	1	23°	56	ATAFR	Wood / MDF	B-57364

Other Plunge Cut Saw Blades

Blade Dia (mm)	(Bore) Hole dia. (mm)	(Kerf) Tip Thickness (mm)	Plate (mm)	Hook Angle (deg)	No. of teeth	Tooth Shape	Application	Part No.
165	20	1.85	1.25	8	48	ATB	Wood	B-56166
165	20	2.2	1.6	8	48	ATB	Wood	B-09298
165	20	2.0	1.4	5	60	TCG	MDF	B-56677
165	20	2.0	1.4	-3	56	TCG	Aluminum	B-56655
165	20	2.4	1.7	-3	56	TCG	Aluminum	B-09307
165	20	2.0	1.4	5	48	TCG	CORIAN®	B-56683

DHS783 185-190mm Acc Pg. A143-160

18V + 18V LXT - Lithium-ion Cordless Circular Saw

Up to 175 cuts
in 2 x 10 SPF 900mm (ripping)
with 2xBL1850B (5.0Ah) batteries

BL ADT MOTOR **AWS XPT (BRAKE)**

High power delivered by Brushless motor, enables to cut as fast as AC slide circular saw.

- Positive stop for bevel adjustment at 22.5 degrees and 45 degrees

Max. bevel capacity **48°** | Blower function | Twin LED Job light | Guide rail compatible base for easy and accurate cutting

Specifications:-

Blade Diameter	190 / 185 mm
Max Cutting Capacity	90°: 62.5 / 60 mm 45°: 44.5 / 43 mm 48°: 42 / 41 mm
No Load Speed (RPM)	6,000
Max Output	1,800 W
Vibration Level	2.5 m/s ² or less
Dimensions (L x W x H)	348x210x290 mm
Net weight	5.1 kg

Standard Equipment: Hex Wrench

5.0Ah	3.0Ah	"Z" VARIANT
DHS783 T2JU INCLUDES 2 BATTERIES / 1 TWO PORT CHARGER / MAKPAC CONNECTOR CASE + BLUETOOTH CHIP	-	DHS783 ZU TOOL ONLY + BLUETOOTH CHIP (DOES NOT INCLUDE BATTERY / CHARGER + MAKPAC CASE)

DHS900 235 mm Acc Pg. A143-160

18V + 18V LXT - Lithium-ion Cordless Circular Saw

Up to 110 cuts
Oak wood (Thickness: 80mm/
Width: 300mm/ Bevel angle: 0°)
with BL1850B (5.0Ah) x 2

BL ADT MOTOR **AWS XPT (BRAKE)** **NEW**

High power delivered by Brushless motor, enables to cut as fast as AC slide circular saw.

- Positive stop for bevel adjustment at 22.5 degrees and 45 degrees

Max. bevel capacity **60°** | Blower function | Twin LED Job light | Guide rail compatible base for easy and accurate cutting

Specifications:-

Blade Diameter	235 mm
Max Cutting Capacity	90°: 85 mm 45°: 61 mm 60°: 44 mm
No Load Speed (RPM)	4,500
Vibration Level	Cutting Wood: 2.5 m/s ² / Cutting Metal: 2.5 m/s ²
Sound Pressure Level	93 dB(A)
Sound Power Level	104 dB(A)
Dimensions (L x W x H)	413x196x316 mm
Net weight	6.0 kg

Standard Equipment: Hex Wrench

5.0Ah	3.0Ah	"Z" VARIANT
DHS900 PT2 INCLUDES 2 BATTERIES / 1 TWO PORT CHARGER / MAKPAC CONNECTOR CASE (DOES NOT INCLUDE BLUETOOTH CHIP)	-	DHS900 ZU TOOL + BLUETOOTH ONLY (DOES NOT INCLUDE BATTERY / CHARGER / MAKPAC CASE) DHS900 Z TOOL ONLY (DOES NOT INCLUDE BATTERY / CHARGER / BLUETOOTH CHIP / MAKPAC CASE)

DRS780 185mm Acc Pg. A143-160

18V+18V LXT - Lithium-ion Cordless Rear Handle Saw

Up to 700 cuts
2x4 SPF lumber cutting at 0 degrees, cross-cut (with BL1860B x2)

BL ADT MOTOR **AWS XPT (BRAKE)**

High durability and High power with BL motor

- Cuts 3X Material in a Single Pass; blade-left rear-handle design
- Two 18V LXT Li-ion batteries deliver the power and performance for corded demands without leaving the 18V LXT platform

Specifications:-

Blade Diameter	185 mm
Max Cutting Capacity	90°: 65 mm 45°: 45 mm 53°: 38 mm
No Load Speed (RPM)	5,100
Dimensions (L x W x H)	446x196x270mm
Net weight	5.6 kg

Standard Equipment: Offset Wrench

AVAILABLE VARIANTS		
5.0Ah	3.0Ah	"Z" VARIANT
-	-	DRS780 Z TOOL ONLY (DOES NOT INCLUDE BATTERY / CHARGER)

Cutting Performance

700 cuts
2x4 SPF lumber cutting at 0 degrees, cross-cut (with BL1860B x2)

Blade-left rear-handle design

Bevel angle up to 53 degrees
Knob and Stopper Construction for Bevel Adjustment with Positive Stops at 22.5 and 45 degrees.

53 degrees

Cuts 3x lumber (63.5 mm or 2-1/2") with max cutting capacity 65 mm.

- CORDLESS
- FIXING / FASTENING
- DRILLING / IMPACT DRILLING
- CONCRETE DRILLING / DEMOLITION
- CUTTING [CONCRETE/ MASONRY/ METAL]
- MULTI TOOL
- GRINDING
- SANDING / POLISHING
- SAWING
- ROUTERING / PLANING
- CLEANING
- HEAT GUN / LASERS
- PNEUMATIC TOOLS
- GARDEN TOOLS
- GENERATORS

CORDLESS
FIXING / FASTENING
DRILLING / IMPACT DRILLING
CONCRETE DRILLING / DEMOLITION
CUTTING (CONCRETE/ MASONRY/ METAL)
MULTI TOOL
GRINDING
SANDING / POLISHING
SAWING
ROUTERING / PLANING
CLEANING
HEAT GUN / LASERS
PNEUMATIC TOOLS
GARDEN TOOLS
GENERATORS

Features :- Model DLS211 / DLS111

ADT

Automatic torque Drive Technology

Automatically changes the cutting speed according to load conditions for an optimum operation:

- On light duty: high-speed rotation mode
- On heavy duty: high torque mode

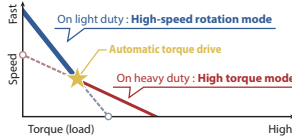

AWS

Auto-stop wireless system

Bluetooth functions starts the dust extractor automatically when the tool starts. Also dust extractor stop on its own when the tool is in rest



BL MOTOR

High power delivered by **Brushless motor**, enables to cut as fast as AC slide compound miter saw.

DXT

High precision cutting by the integrated Guide fence and Lower fence

Rail-forward design enables to be placed against a wall



Independent laser switch Laser marker

Excellent dust collection

One-touch sliding lock can be easily done by removing/ inserting the lock pin

Front knob for easy bevel angle adjustment

High precision cutting
integrated structure of Guide fence and Lower fence makes the fence more rigid, it provides high precision cutting

Easy-to-operate miter angle lock

Large turn base

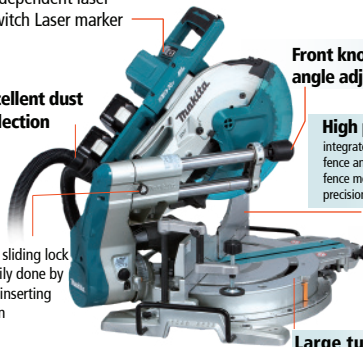

DLS211 305 mm

Acc Pg. A143-161

18V+18V LXT - Lithium-Ion Cordless Slide Compound Miter Saw

18V+18V 36V LITHIUM-ION



BL MOTOR ADT

Powerful / Efficient

DXT AWS

• Combination of Brushless motor, Twin battery system and Miter saw innovation makes the machine more powerful and efficient as similar as corded slide compound miter saw.

Specifications:-



Blade Diameter	305 mm (12")
Miter Angle	60° L / 60° R
Bevel Angle	48° L / 48° R
Max Cutting Capacity	90° Miter: 107 x 363 mm 90° Miter: 92 x 382 mm 45° Miter, L/R: 107 x 255 mm 45° Miter, L/R: 92 x 268 mm
No Load Speed (RPM)	4,400
Vibration Level	2.5 m/s ² or less
Dimensions (L x W x H)	898x690x725 mm
Net weight	28.9 kg

Standard Equipment: Triangular Rule, Vertical Vise, Hex Wrench

AVAILABLE VARIANTS

5.0Ah	3.0Ah	"Z" VARIANT
-	-	DLS211 ZU TOOL ONLY (WITH BLUETOOTH CHIP) (DOES NOT INCLUDE BATTERY / CHARGER)

DLS111 260 mm

Acc Pg. A143-161

18V+18V LXT - Lithium-Ion Cordless Slide Compound Miter Saw

18V+18V 36V LITHIUM-ION

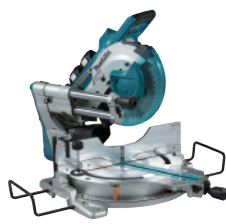

BL MOTOR ADT

Powerful / Efficient

DXT AWS

• Combination of Brushless motor, Twin battery system and Miter saw innovation makes the machine more powerful and efficient as similar as corded slide compound miter saw.

Specifications:-



Blade Diameter	260 mm (10-1/4")
Miter Angle	60° L / 60° R
Bevel Angle	48° L / 48° R
Max Cutting Capacity	90° Miter: 91 x 279 mm (3-5/8" x 11") 90° Miter: 68 x 310 mm (2-11/16" x 12-1/4") 45° Miter, L/R: 91 x 197 mm (3-5/8" x 7-3/4") 45° Miter, L/R: 68 x 218 mm (2-11/16" x 8-5/8")
No Load Speed (RPM)	4,400
Vibration Level	2.5 m/s ² or less
Dimensions (L x W x H)	805x644x660 mm
Net weight	27.3 kg

Standard Equipment: Triangular Rule, Vertical Vise, Hex Wrench

AVAILABLE VARIANTS

5.0Ah	3.0Ah	"Z" VARIANT
-	-	DLS111 ZU TOOL ONLY (WITH BLUETOOTH CHIP) (DOES NOT INCLUDE BATTERY / CHARGER)

DLS714 190mm

Acc Pg. A143-161

18V+18V LXT - Lithium-Ion Cordless Slide Compound Miter Saw

18V+18V 36V LITHIUM-ION



BL MOTOR ADT

High power delivered by Brushless motor, enables to cut as fast as AC slide compound miter saw.

• Automatic speed control; automatically changes the cutting speed according to load conditions for an optimum operation.
• Double sliding mechanism; Makita advantages obtained by using 4 short steel poles with 4 linear ball bearings
• Bevel angle: 45 degrees left to 5 degrees right

Specifications:-



Max output	1,200W
Max cutting capacity	at 0 degrees : 52x300mm / at 45 degrees left:40x300mm at 5 degrees right:40x300mm
Blade diameter	190mm
No load speed (rpm)	5,700
Dimensions (L x W x H)	655x430x445mm
Net weight	12.6kg

Standard Equipment: Hex wrench

5.0Ah	3.0Ah	"Z" VARIANT
-	-	DLS714 Z TOOL ONLY (WITH CARRY CASE) (DOES NOT INCLUDE BATTERY / CHARGER)

DJR360 Acc Pg. A156-157

18V+18V LXT - Lithium-Ion Cordless Reciprocating Saw



Higher durability thanks to more durable mechanism to hold slider & more rigid shoe

- Our most powerful cordless reciprocating saw yet: Amazing work amount & efficiency
- Higher cutting speed and modified stroke length provide higher cutting efficiency.
- Newly designed vertical crank mechanism minimizes blade deflection and reduces vibration to machine.
- Two 18V LXT Li-Ion batteries deliver the power and run time for corded demands.

Specifications:-

Capacity	Pipe : 130mm Wood : 255mm
Length of stroke	32mm
Strokes per minute (spm)	Hi : 0-3,000 Lo : 0-2,300
Dimensions (L x W x H)	448x115x242mm
Net weight	4.0kg

5.0Ah	3.0Ah	"Z" VARIANT
-	-	DJR360 Z TOOL ONLY (WITH CARRY CASE) (DOES NOT INCLUDE BATTERY / CHARGER)



- CORDLESS
- FIXING / FASTENING
- DRILLING / IMPACT DRILLING
- CONCRETE DRILLING / DEMOLITION
- CUTTING [CONCRETE/ MASONRY/ METAL]
- MULTI TOOL
- GRINDING
- SANDING / POLISHING

DVC560

18V+18V LXT - Lithium-Ion Cordless Upright Vacuum Cleaner



Cordless Upright Vacuum to provide both a rotating power brush for deep carpet cleaning & a detachable hand-wand for cleaning with the onboard accessories.

- 3 Stage power selection for optimum suction performance
- Low profile design allows access to more areas
- Compact and lightweight

Specifications:-

Capacity	5.0L
Max. sealed suction	12.0kPa
Max. air volume	1.9m³/min
Working width	318mm
Max. airflow in Litres	30L/sec
Continuous Runtime (2 x 6.0Ah)	H: 30 / N: 60 / L: 120 mins
Overall length	1,146 mm
Net weight	9.0 kg

5.0Ah	3.0Ah	"Z" VARIANT
DVC560 PT2 INCLUDES 2 BATTERIES / 1 TWO PORT CHARGER	-	DVC560 Z TOOL ONLY (WITH CARRY CASE) (DOES NOT INCLUDE BATTERY / CHARGER)



5.0L Capacity disposable bags with high-grade filtration and a HEPA filter that captures up 99.97% of particles at 0.3 micron HEPA Filter (191E39-5)

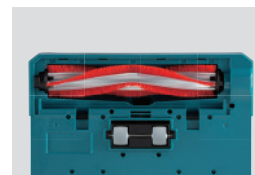

Tool Free brush removal for easy maintenance

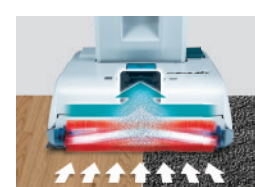

4 stage height adjustment
Features easy dial brush height adjustment, for cleaning carpet or hard floor application

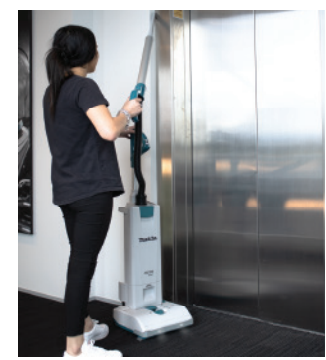

Stretch hose and telescopic tube to clean sills and vents (round brush, long sash nozzle)

Onboard storage for accessories conveniently located on the back of the machine

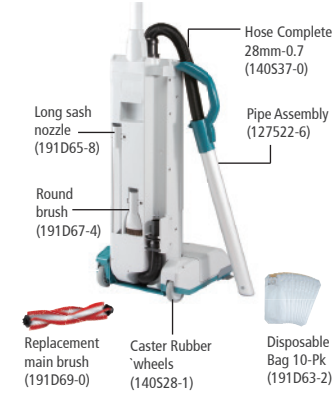

- SAWING
- ROUTERING / PLANING
- CLEANING
- HEAT GUN / LASERS
- PNEUMATIC TOOLS
- GARDEN TOOLS
- GENERATORS

CORDLESS
FIXING / FASTENING
DRILLING / IMPACT DRILLING
CONCRETE DRILLING / DEMOLITION
CUTTING [CONCRETE/ MASONRY/ METAL]
MULTI TOOL
GRINDING
SANDING / POLISHING
SAWING
ROUTERING / PLANING
CLEANING
HEAT GUN / LASERS
PNEUMATIC TOOLS
GARDEN TOOLS
GENERATORS

DVC665
Tool Attachments Pg. T247-254 | Acc Pg. A189-195

18V+18V LXT - Lithium-ion Cordless Backpack Dust Extractor
(Dry only)



6L
Capacity



18V+18V LXT LITHIUM-ION 36V

BL MOTOR

HEPA filter

AWS

Backpack dust extractor powered by two 18V Li-ion batteries. Best suitable for working with power tools.

- 6.0L Large dust bag capacity for continuous operation
- Quiet operating achieved with noise reduction construction
- Featuring shoulder and waist belts adjustable to suit user's size for less fatigue even after long continuous operation
- Mode memory function allows to start in the same suction power when you turned it off previously
- Push button power selection controller (high/normal) with AWS function

Two stage HEPA filtration system
system captures 99.97% of particulates .3 microns and larger



Controller With

- Wireless unit
- 2 Stage power selection

Easily accessible side-loading batteries
for added convenience

Specifications:-

Capacity	Paper dust bag: 6.0 L Cloth dust bag: 5.5 L
Continuous Use (min.)	High / Normal: 40 / 75 (with BL1860B x2)
Max Air Flow	1.8 m³/min (28mm-1.5m Hose)
Max Sealed Suction	11 kPa
Max Suction Power	High / Normal: 85 / 45 W (28mm-1.5m Hose)
Vibration Level	Operation w/o Load: 2.5 m/s² or less
Sound Pressure Level	High: 66 / Normal: 62dB(A)
Dimensions (L x W x H)	297x174x523 mm
Net weight	6.7 kg

Standard Equipment: 28mm dia 1.5m hose, front cuff 22 ,38, Rubber joint 24, Paper bag

AVAILABLE VARIANTS

5.0Ah	3.0Ah	"Z" VARIANT
-	-	DVC665 Z TOOL ONLY (DOES NOT INCLUDE BATTERY / CHARGER BLUETOOTH CHIP OR CARRY CASE)

DVC265
Tool Attachments Pg. T247-254 | Acc Pg. A189-195

18V+18V LXT - Lithium-ion Cordless Backpack Dust Extractor
(Dry only)



2L
Capacity

18V+18V LXT LITHIUM-ION 36V

BL MOTOR

HEPA filter

AWS

Backpack dust extractor powered by two 18V Li-ion batteries. Best suitable for working with power tools.

- Featuring shoulder and waist belts adjustable to suit user's size for less fatigue even after long continuous operation
- Mode memory function allows to start in the same suction power when you turned it off previously
- Push button power selection controller (high/normal) with AWS function

Two stage HEPA filtration system
system captures 99.97% of particulates .3 microns and larger



Controller With

- Wireless unit
- 2 Stage power selection

Specifications:-

Capacity	Paper Dust Bag: 2.0 L Cloth Dust Bag: 1.5 L
Continuous Use (min.)	High: 40 / Low: 75 (with BL1860B)
Max Air Flow	1.8 m³/min (28mm-1.5m Hose)
Max Sealed Suction	11 kPa
Suction Power	High / Normal: 85 / 45 W (28mm-1.5m Hose)
Vibration Level	Operation without Load: 2.5 m/s² or less
Sound Pressure Level	High: 69 / Normal: 65dB(A)
Dimensions (L x W x H)	230x152x373 mm
Net weight	4.5 kg

Standard Equipment: 28mm dia 1.5m hose, front cuff 22 ,38, Rubber joint 24, Paper bag

AVAILABLE VARIANTS

5.0Ah	3.0Ah	"Z" VARIANT
-	-	DVC265 ZXU TOOL ONLY (WITH BLUETOOTH CHIP) (DOES NOT INCLUDE BATTERY / CHARGER OR CARRY CASE)

DVC660
Tool Attachments Pg. T247-254 | Acc Pg. A189-195

18V+18V LXT - Lithium-ion Cordless Backpack Vacuum Cleaner



36V
LITHIUM-ION
BL MOTOR
HEPA filter

(Dry only)



6L
Capacity

Backpack vacuum cleaner powered by two 18V Li-ion batteries.

- 6.0L Large dust bag capacity for continuous operation
- Durable 32mm - 1m hose (standard)
- Quiet operating achieved with noise reduction onstruction
- Featuring shoulder and waist belts adjustable to suit user's size for less fatigue even after long continuous operation
- Mode memory function allows to start in the same suction power when you turned it off previously
- Push button power selection controller (max/high/normal) with LED job light.

Two stage HEPA filtration system
system captures 99.97% of particulates .3 microns and larger

Cleaning mechanism with paper dust bag
Dust that tending to clog filters actuated automatically due to vibration or pulling down lever manually

Aluminium telescope pipe with lock system prevents the pipe unintentionally coming off

Easily accessible side-loading batteries for added convenience



Specifications:- 

Capacity	Paper dust bag: 6.0 L / Cloth dust bag: 5.5 L
Continuous Use (min.)	Max: 40 / High: 75 / Normal: 140 (with BL1860B x2)
Max Air Flow	2.2 m³/min (32mm-1m Hose)
Max Sealed Suction	11 kPa
Max Suction Power	Max / High / Normal: 95 / 50 / 25 W (32mm-1m Hose)
Vibration Level	Operation w/o Load: 2.5 m/s² or less
Sound Pressure Level	Max: 66 / High: 62 / Normal: 58 dB(A)
Dimensions (L x W x H)	297x174x523 mm
Net weight	6.7 kg

Standard Equipment: 32mm dia 1m hose, Floor Nozzle, Hose, Hose Band, Nozzle assembly, Telescopic pipe assembly, Bent Pipe, Seat nozzle, Round Brush, Flexible Nozzle, Dust Bag.

AVAILABLE VARIANTS

5.0Ah	3.0Ah	"Z" VARIANT
-	-	DVC660 ZX8 TOOL ONLY (DOES NOT INCLUDE BATTERY / CHARGER OR CARRY CASE)

DVC261
Tool Attachments Pg. T247-254 | Acc Pg. A189-195

18V+18V LXT - Lithium-ion Cordless Backpack Vacuum Cleaner



36V
LITHIUM-ION
BL MOTOR
HEPA filter

(Dry only)

2L
Capacity

Backpack vacuum cleaner powered by two 18V Li-ion batteries.

- Featuring shoulder and waist belts adjustable to suit user's size for less fatigue even after long continuous operation
- Mode memory function allows to start in the same suction power when you turned it off previously
- Delivers up to 140 min of run time using BL1860B on normal setting
- Push button power selection controller (max/high/normal) with LED job light

Two stage HEPA filtration system
system captures 99.97% of particulates .3 microns and larger



Specifications:- 

Capacity	Paper Dust Bag: 2.0 L / Cloth Dust Bag: 1.5 L
Continuous Use (min.)	Max: 40 / High: 75 / Normal: 140 (with BL1860B x 2)
Max Air Flow	2.0 m³/min (28mm-1m Hose)
Max Sealed Suction	11 kPa
Suction Power	Max / High / Normal : 90 / 45 / 25 W (28mm-1m Hose)
Vibration Level	Operation w/o Load: 2.5 m/s² or less
Sound Pressure Level	Max: 69 / High: 65 / Normal: 62 dB(A)
Dimensions (L x W x H)	230x152x373 mm
Net weight	4.5 kg

Standard Equipment: 28mm dia 1m hose, Floor Nozzle, Hose, Hose Band, Nozzle assembly, Telescopic pipe assembly, Bent Pipe, Flexible Nozzle, Dust Bag

AVAILABLE VARIANTS

5.0Ah	3.0Ah	"Z" VARIANT
-	-	DVC261 ZX11 TOOL ONLY (DOES NOT INCLUDE BATTERY / CHARGER OR CARRY CASE)

CORDLESS
FIXING / FASTENING
DRILLING / IMPACT DRILLING
CONCRETE DRILLING / DEMOLITION
CUTTING [CONCRETE/ MASONRY/ METAL]
MULTI TOOL
GRINDING
SANDING / POLISHING
SAWING
ROUTERING / PLANING
CLEANING
HEAT GUN / LASERS
PNEUMATIC TOOLS
GARDEN TOOLS
GENERATORS

- CORDLESS
- FIXING / FASTENING
- DRILLING / IMPACT DRILLING
- CONCRETE DRILLING / DEMOLITION
- CUTTING [CONCRETE/ MASONRY/ METAL]
- MULTI TOOL
- GRINDING
- SANDING / POLISHING
- SAWING
- ROUTERING / PLANING
- CLEANING
- HEAT GUN / LASERS
- PNEUMATIC TOOLS
- GARDEN TOOLS
- GENERATORS

DVC154L
Tool Attachments Pg. T247-254 | Acc Pg. A189-195

18V+18V LXT - Lithium-ion Cordless Dust Extractor with AWS
 (DRY)



NEW



15L

Large dust bag capacity with Hepa Filter System
for powerful dust extracting solutions





Built-in wireless unit

Auto-start wireless system enables the Dust Extractor runs automatically





Efficient three stage HEPA filtration system
captures 99.97% of particulates 0.3 microns and larger





Higher suction power due to brushless motor

Specifications:-

Capacity	Dust : 15 L
Continuous Use (min.) (approx.)	With 2 x BL1850B: 40-100 / With 2 x BL1860B: 48-115
Max Air Flow	2.1 m³/min
Max Sealed Suction	9.8 kPa
Max Suction Power	90 W
Vibration Level	2.5 m/s² or less
Sound Pressure Level	66 dB(A)
Dimensions (L x W x H)	366x334x421 mm
Net weight	8.6 kg

Standard Equipment: Front Cuffs, 28mm Dia - 3.5m Hose, Hepa Filter Set, Polybag Set.

AVAILABLE VARIANT

"Z" VARIANT

DVC154LZ
TOOL ONLY (DOES NOT INCLUDE BATTERY / CHARGER OR CARRY CASE)

DVC864L
Tool Attachments Pg. T247-254 | Acc Pg. A189-195

18V+18V LXT - Lithium-ion Cordless Dust Extractor with AWS
 (DRY)





8L

Dust bag capacity with Hepa Filter System
for powerful dust extracting solutions





Built-in wireless unit

Auto-start wireless system enables the Dust Extractor runs automatically





Efficient three stage HEPA filtration system
captures 99.97% of particulates 0.3 microns and larger





Higher suction power due to brushless motor

Specifications:-

Capacity	Dust: 8 L
Continuous Use (min.)	40 min (with BL1850B x2)
Suction Power	High: 90W
Max Air Flow	2.1 m³/min
Max Sealed Suction	9.8 kPa
Vibration Level	2.5 m/s² or less
Sound Pressure Level	70 dB(A) or less
Dimensions (L x W x H)	366x334x368 mm
Net weight	8.4 kg

Standard Equipment: Front Cuffs, 28mm Dia - 3.5m Hose, Hepa Filter Set, Polybag Set.

AVAILABLE VARIANT

"Z" VARIANT

DVC864LZ
TOOL ONLY (DOES NOT INCLUDE BATTERY / CHARGER OR CARRY CASE)

DVC150L

Tool Attachments Pg. T247-254 | Acc Pg. A189-195

18V+18V LXT - Lithium-ion Cordless + Corded Vacuum Cleaner (WET & DRY)



15L Large dust bag capacity with cloth filter system enables continuous cleaning work



Versatile Use: Thanks to 2 different Power Sources Provides easy maneuverability anywhere you need cleaning



Specifications:-

Capacity	Dust / Water: 15 / 12 L
Continuous Use (min.)	With 2 x BL1850B: 30-65 / With 2 x BL1860B: 36-78
Max Air Flow	AC / DC: 3.6 / 2.1 m³/min
Max Sealed Suction	AC / DC: 24 / 9 kPa
Max Suction Power	AC / DC: 320 / 70 W
Vibration Level	2.5 m/s² or less
Sound Pressure Level	AC / DC: 75 / 64 dB(A)
Dimensions (L x W x H)	366x334x421 mm
Net weight	9.6 kg

Standard Equipment: Floor Nozzle, Corner Nozzle, Bend Pipe, Straight Pipe, 38mm Dia - 2.5m Hose, Cloth Filter, Poly Bag Set

AVAILABLE VARIANT

"Z" VARIANT

DVC150LZ
TOOL ONLY (DOES NOT INCLUDE BATTERY / CHARGER OR CARRY CASE)

DVC860L

Tool Attachments Pg. T247-254 | Acc Pg. A189-195

18V+18V LXT - Lithium-ion Cordless + Corded Vacuum Cleaner (WET & DRY)



8L Dust bag capacity with cloth filter system enables continuous cleaning work



Versatile Use: Thanks to 2 different Power Sources Provides easy maneuverability anywhere you need cleaning



Specifications:-

Capacity	Dust / Water: 8 / 6 L
Continuous Use (min.)	65 min. (with BL1850B x 2)
Max Air Flow	AC / DC: 3.6 / 2.1 m³/min
Max Sealed Suction	AC / DC: 24 / 9 kPa
Vibration Level	2.5 m/s² or less
Sound Pressure Level	75 dB(A)
Dimensions(L x W x H)	366x334x368 mm
Net weight	8.6 kg

Standard Equipment: Floor Nozzle, Corner Nozzle, Bend Pipe, Straight Pipe, 38mm Dia - 2.5m Hose, Cloth Filter, Poly Bag Set

AVAILABLE VARIANT

"Z" VARIANT

DVC860LZ
TOOL ONLY (DOES NOT INCLUDE BATTERY / CHARGER OR CARRY CASE)

CORDLESS

FIXING / FASTENING

DRILLING / IMPACT DRILLING

CONCRETE DRILLING / DEMOLITION

CUTTING [CONCRETE/ MASONRY/ METAL]

MULTI TOOL

GRINDING

SANDING / POLISHING

SAWING

ROUTERING / PLANING

CLEANING

HEAT GUN / LASERS

PNEUMATIC TOOLS

GARDEN TOOLS

GENERATORS

18V LITHIUM-ION



18V Lithium-ion ONE STEP

LXT

18V LITHIUM-ION

Recipro Saw

Rear Handle Saw

Rotary Hammer

Stapler

Slide Compound Miter Saw

Combination Hammer

Portable Cut-off

Concrete Vibrator

Pin Nailer

Finish Nailer

Wheelbarrow

Caulking Gun

Hole Puncher

Rebar Tying Tool

Rivet Gun

Grease Gun

Brad Nailer

Shear Wrench

Angle Drill

Rechargeable Flashlight

Vacuum Pump

Flashlight Radio

Flashlight

LED Flashlight

LED Worklight

Inflator

Fan

Area Worklight

Fan Jacket

Heated Blanket

Fan Vest

Heated Jacket

Heated Vest

Coffee Maker

Job Site Radio

Job Site Speaker

Chain Saw

Blower

Hedge Trimmer

Robotic Cleaner

Trimmer

Grass Shear

Vacuum Cleaner

Recipro Saw

Drywall Saw

Grass Trimmer

Cleaner

Portable Vacuum Cleaner

Planer

String Trimmer

Cyclone Cleaner

Cut-Out Tool

Jig Saw

Cyclone Cleaner

Plate Joiner



Chain Saw

Angle Grinder

Grass Trimmer

Pruning Shears

Circular Saw

Blower

Portable Power Pack

Lawn Mower

Plunge Cut Saw

Vacuum Cleaner

Multi Function Power Head

Hedge Trimmer

Impact Wrench

Power Cutter

Backpack Vacuum Cleaner

Auto Feed Screwdriver

Mixer

4 Mode Impact Driver

18Vx2

Angle Drill

Angle Impact Wrench

Oil-Pulse Driver

Driver Drill

Impact Driver

SYSTEM ENDLESS POSSIBILITIES

Hammer Driver Drill

Rotary Hammer

Power Scraper

Combination Hammer

Multi Tool

Metal Shear

Steel Rod Cutter

Metal Cutter

Circular Saw

Nibbler

Die Grinder

Portable Band Saw

Random Orbit Polisher

Threaded Rod Cutter

Slide Compound Miter Saw

Drywall Sander

Random Orbit Sander

Angle Grinder

Compound Miter Saw

Expand Your Lithium Line Up

CORDLESS
FIXING / FASTENING
DRILLING / IMPACT DRILLING
CONCRETE DRILLING / DEMOLITION
CUTTING [CONCRETE/ MASONRY/ METAL]
MULTI TOOL
GRINDING
SANDING / POLISHING
SAWING
ROUTERING / PLANING
CLEANING
HEAT GUN / LASERS
PNEUMATIC TOOLS
GARDEN TOOLS
GENERATORS

DHR242 24mm (Adapted for SDS-Plus bits) Acc Pg. A062-079

18V LXT - Lithium-Ion Cordless Combination Hammer



Efficient brushless DC motor provides higher productivity.

- Excellent maneuverability achieved by in-line grip and ideal gravity point close to handle for easy machine thrust.
- Versatile 3-Mode operation - Hammering, Hammering with rotation and Rotation.
- Unique rubber joint construction to suppress the transmission of vibration.
- Can be attached with the dust extraction system DX01 **Part no: 195897-1** (optional).

Specifications:-

Impact Energy	2.0 J
Capacity	Concrete: 24 mm / Steel: 13 mm / Wood: 27 mm
Impacts Per Minute (IPM)	0-4,700
No Load Speed (RPM)	0-950
Sound Pressure Level	90 dB(A)
Sound Power Level	101 dB(A)
Vibration Level	Hammer Drilling Into Concrete: 13.5 m/s ² Chiseling: 10.5 m/s ² / Drilling: 3.5 m/s ²
Dimensions (L x W x H)	328x85x213mm
Net weight	3.8 kg

Standard Equipment: Depth Gauge, Side Grip. (Tool does not come with bit.)

AVAILABLE VARIANTS			
6.0Ah	5.0Ah	3.0Ah	"Z" VARIANT
DHR242 RGJ INCLUDES 2 BATTERIES / 1 CHARGER / MAKPAC CONNECTOR CASE	DHR242 RTJ INCLUDES 2 BATTERIES / 1 CHARGER / MAKPAC CONNECTOR CASE	DHR242 RFJ INCLUDES 2 BATTERIES / 1 CHARGER / MAKPAC CONNECTOR CASE	DHR242 Z TOOL ONLY (DOES NOT INCLUDE BATTERY / CHARGER / CARRYING CASE)

DHR202 20mm (Adapted for SDS-Plus bits) Acc Pg. A062-079 **441**

18V LXT - Lithium-Ion Cordless Combination Hammer



High operation efficiency with high torque.

- Versatile 3-Mode operation - Hammering, Hammering with rotation and Rotation.
- Unique rubber joint construction to suppress the transmission of vibration.
- Torque limiter operates to stop when drill bits hit against reinforcements.
- LED job light with afterglow function.
- Rubberized soft grip provides more and control and comfort.

Specifications:-

Impact Energy	1.9 J
Capacity	Concrete : 20mm Steel : 13mm Wood : 26mm
Blows per minute	0-4,000 bpm
No load speed	0-1,100 rpm
Dimensions (L x W x H)	358 x 84 x 259mm
Net weight	4.0 kg

Standard Equipment: Depth Gauge, Side Grip. (Tool does not come with bit.)

AVAILABLE VARIANTS		
5.0Ah	3.0Ah	"Z" VARIANT
DHR202 RTJ INCLUDES 2 BATTERIES / 1 CHARGER / MAKPAC CONNECTOR CASE	DHR202 RFJ INCLUDES 2 BATTERIES / 1 CHARGER / MAKPAC CASE	DHR202 Z TOOL ONLY (DOES NOT INCLUDE BATTERY / CHARGER / CARRYING CASE)

DHR182 18mm (Adapted for SDS-Plus bits) Acc Pg. A062-079

18V LXT - Lithium-Ion Cordless Combination Hammer with Dust Extract System DX05



The Lightest Combination Hammer with Dust Collection system

- Compact and lightweight for reduced operator fatigue

Specifications:-

Impact Energy	1.7 J
Capacity	Concrete: 18 mm / Steel: 13 mm / Wood: 24 mm
Blows Per Minute (BPM)	0 - 5,000
No Load Speed (RPM)	0 - 1,350
Vibration Level	Hammer Drilling into Concrete: 11.0 m/s ² Drilling Into Metal: 2.5 m/s ² or less
Sound pressure Level	89 dB(A)
Sound power Level	100 dB(A)
Dimensions (L x W x H)	301x82x285 mm
Net weight	3.6 kg (with Dust Extractor)

Standard Equipment: Dust Cup, Side Grip, Depth Gauge, (Tool does not come with bit.)

AVAILABLE VARIANTS		
5.0Ah	3.0Ah	"Z" VARIANT
		DHR182 ZWJU TOOL ONLY (WITH MAKPAC CASE + BLUETOOTH CHIP (DOES NOT INCLUDE BATTERY / CHARGER)

BL MOTOR



BL motor with high power to weight and size ratio

AWS

Auto-start Wireless System



Wireless unit (Bluetooth chip) Bluetooth

AVT

Equipped with the same AVT (Anti-Vibration Technology) and features are the best balance of low vibration and lightweight.

Filter cleaning mechanism

by turning the dial, the dust falls off from the filter



HEPA filter



Max Bit length 165mm

with DX05

(Dust Extract System DX05 Part # 199658-1)

DHR171 17mm (Adapted for SDS-Plus bits) Acc Pg. A062-079

18V LXT - Lithium-Ion Cordless Rotary Hammer



1.2 Joules 2 mode

Extremely Compact and Lightweight for increased maneuverability

- BL Motor Delivers 0-680 RPM, 0-4,800 BPM and 1.2 Joules of Impact Energy for Faster Drilling
- Vibration absorbing housing and ergonomic soft rubber grip design for vibration absorption and comfortable operation
- BL motor with high power to weight and size ratio

Specifications:-

Impact Energy	1.2 J
Capacity	Concrete: 17 mm / Steel: 10 mm / Wood: 13 mm
Blows Per Minute (BPM)	0 - 4,800
No Load Speed (RPM)	0 - 680
Vibration Level	Hammer Drilling Into Concrete: 9.0 m/s ² Drilling Into Metal: 2.5 m/s ² or less
Sound Pressure Level	86 dB(A)
Sound Power Level	97 dB(A)
Dimensions (L x W x H)	273x86x211 mm
Net weight	2.8 kg

Standard Equipment: Side Grip, Depth Gauge (Tool does not come with bit.)

AVAILABLE VARIANTS		
5.0Ah	3.0Ah	"Z" VARIANT
	DHR171 RFJ INCLUDES 2 BATTERIES / 1 CHARGER / MAKAPAC CONNECTOR CASE	DHR171 Z TOOL ONLY (DOES NOT INCLUDE BATTERY / CHARGER / CARRYING CASE)

DHK180 (Adapted for SDS-Plus bits) Acc Pg. A071-079

18V LXT - Lithium-Ion Cordless Power Scraper



3.1 Joules

High Power, Low Vibration, Compact and Lightweight Power Scraper

- Anti-vibration housing and AVT for reduced operator fatigue
- BL motor delivers high power
- Compact and lightweight
- Excellent maneuverability
- Twin LED job light

Specifications:-

Impact Energy	3.1 J
Blows Per Minute (BPM)	0 - 3,200
Vibration Level	Chiselling: 4.5 m/s ²
Sound Pressure Level	83 dB(A)
Sound Power Level	94 dB(A)
Dimensions (L x W x H)	368x99x211 mm
Net weight	3.6 kg

AVAILABLE VARIANTS

5.0Ah	3.0Ah	"Z" VARIANT
		DHK180 Z TOOL ONLY (DOES NOT INCLUDE BATTERY / CHARGER / CARRYING CASE)

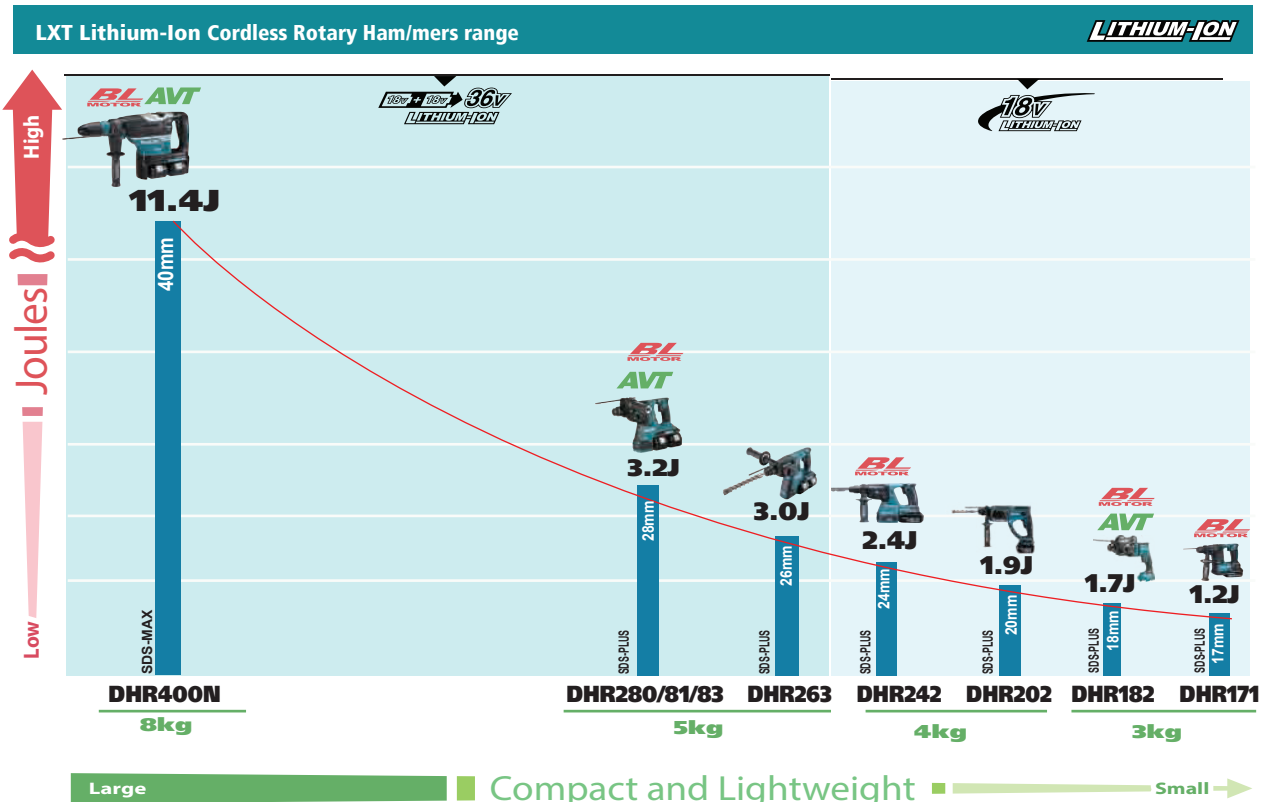

- CORDLESS
- FIXING / FASTENING
- DRILLING / IMPACT DRILLING
- CONCRETE DRILLING / DEMOLITION
- CUTTING [CONCRETE/ MASONRY/ METAL]
- MULTI TOOL
- GRINDING
- SANDING / POLISHING
- SAWING
- ROUTERING / PLANING
- CLEANING
- HEAT GUN / LASERS
- PNEUMATIC TOOLS
- GARDEN TOOLS
- GENERATORS

CORDLESS
FIXING / FASTENING
DRILLING / IMPACT DRILLING
CONCRETE DRILLING / DEMOLITION
CUTTING (CONCRETE/ MASONRY/ METAL)
MULTI TOOL
GRINDING
SANDING / POLISHING
SAWING
ROUTERING / PLANING
CLEANING
HEAT GUN / LASERS
PNEUMATIC TOOLS
GARDEN TOOLS
GENERATORS

DDF481 13mm Acc Pg. A024-060 **440** 

18V LXT - Lithium-Ion Cordless Driver Drill



Newly developed large brushless motor provides higher power and productivity.

- Max lock torque: 125N m. (1,090in lbs)
- Compact tool size with an overall length of 205mm (8-1/8")

Specifications:- 

Capacity	Steel : 13mm (1/2") Wood : 76mm (3")
No load speed (rpm)	Hi : 0-2,100 Lo : 0-550
Max fastening torque	Hard / Soft : 115 / 60N m
Dimensions (L x W x H)	205x79x249mm
Net weight	3kg

Standard Equipment: (+)(-) bit, Side grip

AVAILABLE VARIANTS		
5.0Ah	3.0Ah	"Z" VARIANT
DDF481 RTJ INCLUDES 2 BATTERIES / 1 CHARGER / MAKPAC CONNECTOR CASE	DDF481 RFJ INCLUDES 2 BATTERIES / 1 CHARGER / MAKPAC CONNECTOR CASE	DDF481 Z TOOL ONLY (DOES NOT INCLUDE BATTERY / CHARGER / CARRYING CASE)

DDF482 13mm Acc Pg. A024-060 **440** 

18V LXT - Lithium-Ion Cordless Driver Drill

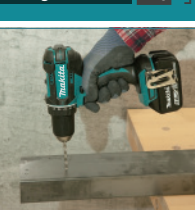
Developed as the successor to the current model DDF456

- High rotational speed: 1,900 rpm (High) and 600 rpm (Low)
- Compact and lightweight design
- Newly designed ergonomic handle
- Twin LED job light

Specifications:- 

Capacity	Steel : 13mm Wood : 38mm
No load speed (rpm)	Hi : 0-1,900 Lo : 0-600
Max tightening torque	Hard / Soft : 62 / 36N m
Dimensions (L x W x H)	185x79x232mm
Net weight	1.8kg

Standard Equipment: (+)(-) bit 2-45, Belt clip

AVAILABLE VARIANTS		
5.0Ah	3.0Ah	"Z" VARIANT
DDF482 RTJ INCLUDES 2 BATTERIES / 1 CHARGER / MAKPAC CONNECTOR CASE	DDF482 RFJ INCLUDES 2 BATTERIES / 1 CHARGER / MAKPAC CONNECTOR CASE	DDF482 Z TOOL ONLY (DOES NOT INCLUDE BATTERY / CHARGER OR CARRYING CASE)

DDF451 13mm Acc Pg. A024-060 **436** 

18V LXT - Lithium-Ion Cordless Driver Drill



Original 4-pole motor for power, light-weight and compact size.

- Robust body construction with aluminium gear housing.
- Shift-Lock drive system to quickly shift between modes.
- Best fit ergonomic grip shape.
- Twin LED job light with after glow function.
- Anti-slip rubberized side grip.

Specifications:- 

Capacity	Steel : 13mm (1/2") Wood : 65mm (2-9/16")
No load speed (rpm)	1st: 0-300; 2nd: 0-600; 3rd: 0-1,700
Max. fastening torque	Hard / Soft : 80 / 40N.m
Dimensions (L x W x H)	238 x 78 x 257mm
Net weight	2.6kg

Standard Equipment: (+)(-) bit, Grip Assembly.

AVAILABLE VARIANTS		
5.0Ah	3.0Ah	"Z" VARIANT
DDF451 RTJ INCLUDES 2 BATTERIES / 1 CHARGER / MAKPAC CONNECTOR CASE	TOOL ONLY (DOES NOT INCLUDE BATTERY / CHARGER / CARRYING CASE)	DDF451 Z TOOL ONLY (DOES NOT INCLUDE BATTERY / CHARGER / CARRYING CASE)

DDF484 13mm Acc Pg. A024-060

18V LXT - Lithium-Ion Cordless Driver Drill



Powerful Brushless motor & Compact and ergonomic design

- Delivers more drilling, driving and fastening speed
- Aluminum gear housing creates an impression of rigidity and luxuriousness
- Variable 2-speed for a wide range of drilling and fastening applications
- Built-in twin LED lights with pre-glow and afterglow functions illuminate the work area

Specifications:- 

Capacity	Steel / Wood: 13 / 38 mm
Chuck capacity	1.5 - 13 mm
No Load Speed (RPM)	High / Low: 0 - 2,000 / 0 - 500
Max Fastening Torque	Hard / Soft: 54 / 30 N m
Dimensions (L x W x H)	172x79x261 mm
Net weight	1.8 kg

Standard Equipment: (+)(-) bit, Belt clip

AVAILABLE VARIANTS		
5.0Ah	3.0Ah	"Z" VARIANT
DDF484 RTJ INCLUDES 2 BATTERIES / 1 CHARGER / MAKPAC CONNECTOR CASE	DDF484 RFJ INCLUDES 2 BATTERIES / 1 CHARGER / MAKPAC CONNECTOR CASE	DDF484 Z TOOL ONLY (DOES NOT INCLUDE BATTERY / CHARGER / CARRYING CASE)

DDF453 13mm Acc Pg. A024-060

18V LXT - Lithium-Ion Cordless Driver Drill



All metal gear construction ensures high transmission durability

- Single sleeve keyless chuck enables easy bit installation/removal with one hand.
- Ergonomically designed rubberized soft grip provides more control and comfort.

Specifications:-

Capacity	Steel: 13 mm / Wood: 36 mm
No load speed (rpm)	High: 0-1,300 / Low: 0-400
Max. fastening torque	Hard / Soft: 42 / 27 N m
Dimensions (L x W x H)	222x79x244 mm
Net weight	2 kg

Standard Equipment: (+)(-) bit, Belt clip

AVAILABLE VARIANTS		
5.0Ah	3.0Ah	"Z" VARIANT
-	DDF453 RFE INCLUDES 2 BATTERIES / 1 CHARGER / PLASTIC CARRYING CASE	-

DDF483 13mm Acc Pg. A024-060

18V LXT - Lithium-Ion Cordless Driver Drill



New Ultra-compact and ergonomic design at only 162mm long and lightweight for reduced operator fatigue

- Brushless motor provides higher power and productivity
- Variable 2-speed for a wide range of drilling and fastening applications

Specifications:-

Capacity	Steel / Wood: 13 / 36 mm
Chuck capacity	1.5 - 13 mm
No Load Speed (RPM)	High / Low: 0 - 1,700 / 0 - 500
Max Fastening Torque	Hard / Soft: 40 / 23 N m
Dimensions (L x W x H)	162x79x247 mm
Net weight	1.6 kg

Standard Equipment: (+)(-) bit, Belt clip

AVAILABLE VARIANTS		
5.0Ah	3.0Ah	"Z" VARIANT
DDF483 RTJ INCLUDES 2 BATTERIES / 1 CHARGER / MAKPAC CONNECTOR CASE	DDF483 RFJ INCLUDES 2 BATTERIES / 1 CHARGER / MAKPAC CONNECTOR CASE	DDF483 Z TOOL ONLY (DOES NOT INCLUDE BATTERY / CHARGER / CARRYING CASE)

- CORDLESS
- FIXING / FASTENING
- DRILLING / IMPACT DRILLING
- CONCRETE DRILLING / DEMOLITION
- CUTTING [CONCRETE/ MASONRY/ METAL]
- MULTI TOOL
- GRINDING
- SANDING / POLISHING
- SAWING
- ROUTERING / PLANING
- CLEANING
- HEAT GUN / LASERS
- PNEUMATIC TOOLS
- GARDEN TOOLS
- GENERATORS

18V LXT - LITHIUM-ION CORDLESS DRIVER DRILL - COMPARISON CHART

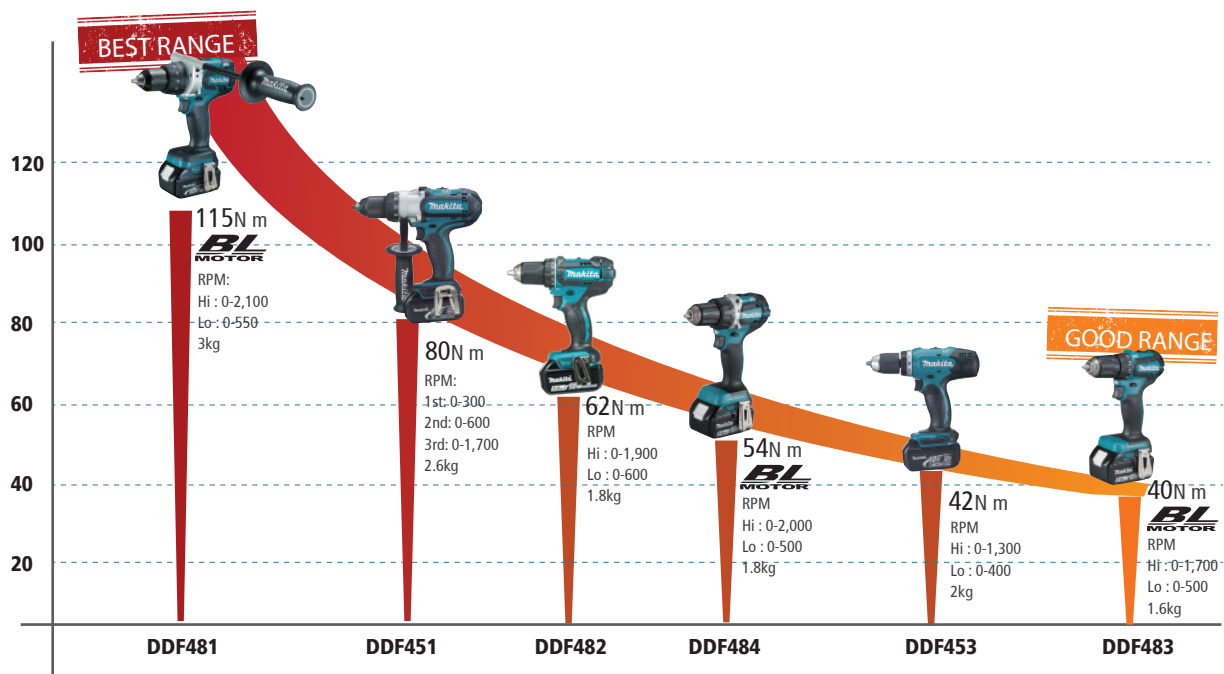

CORDLESS
FIXING / FASTENING
DRILLING / IMPACT DRILLING
CONCRETE DRILLING / DEMOLITION
CUTTING (CONCRETE/ MASONRY/ METAL)
MULTI TOOL
GRINDING
SANDING / POLISHING
SAWING
ROUTERING / PLANING
CLEANING
HEAT GUN / LASERS
PNEUMATIC TOOLS
GARDEN TOOLS
GENERATORS

DHP481 13mm Acc Pg. A024-060

18V LXT - Lithium-Ion Cordless Percussion Driver Drill



Newly developed large brushless motor provides higher power and productivity.

- Features the highest torque in the industry.
- Compact tool size with an overall length of 205mm.

Specifications:-

Capacity	Steel : 13mm / Wood : 76mm Masonry : 16mm
Impacts per minute (ipm)	Hi : 0-31,500 / Lo : 0-8,250
No load speed (rpm)	Hi : 0-2,100 / Lo : 0-550
Max fastening torque	Hard / Soft : 115 / 60N m
Dimensions (L x W x H)	205x79x249mm
Net weight	3.0kg

Standard Equipment: (+)(-) bit, Side Grip, Belt clip

AVAILABLE VARIANTS		
5.0Ah	3.0Ah	"Z" VARIANT
DHP481 RTJ INCLUDES 2 BATTERIES / 1 CHARGER / MAKPAC CONNECTOR CASE	DHP481 RFJ INCLUDES 2 BATTERIES / 1 CHARGER / MAKPAC CONNECTOR CASE	DHP481 Z TOOL ONLY (DOES NOT INCLUDE BATTERY / CHARGER / CARRYING CASE)

DHP451 13mm Acc Pg. A024-060 **440** mm

18V LXT - Lithium-Ion Cordless Percussion Driver Drill



Original 4-pole motor

- Robust body construction with aluminium gear housing.
- Best fit ergonomic grip shape.
- Twin LED job light with after glow function.
- Anti-slip rubberized side grip.

Specifications:-

Capacity	Steel : 13mm Wood : 65mm Masonry : 16mm
Impacts per minute (ipm)	3rd : 0-25,500 2nd : 0-9,000 1st : 0-4,500
No load speed (rpm)	3rd : 0-1,700 2nd : 0-600 1st : 0-300
Max. fastening torque	Hard / Soft : 80 / 40N m
Dimensions (L x W x H)	250x78x257mm
Net weight	2.9kg

Standard Equipment: (+)(-) bit, Grip Assembly.

AVAILABLE VARIANTS		
5.0Ah	3.0Ah	"Z" VARIANT
DHP451 RTJ INCLUDES 2 BATTERIES / 1 CHARGER / MAKPAC CONNECTOR CASE	-	DHP451 Z TOOL ONLY (DOES NOT INCLUDE BATTERY / CHARGER OR CARRYING CASE)

DHP482 13mm Acc Pg. A024-060 **440** mm

18V LXT - Lithium-Ion Cordless Percussion Driver Drill



Developed as the successor to the current model DHP456.

- Compact overall length: 198mm for increased maneuverability
- Lightweight design
- Higher speed of 1,900 rpm (High) and 600 rpm (Low)
- Newly designed ergonomic handle
- Higher luminance twin LED Job light with preglow and afterglow functions

Specifications:-

Capacity	Steel / Wood / Masonry: 13 / 38 / 13 mm
Chuck capacity	1.5 - 13 mm
Impacts Per Minute (IPM)	High / Low: 0 - 28,500 / 0 - 9,000
No Load Speed (RPM)	High / Low: 0 - 1,900 / 0 - 600
Max Fastening Torque	Hard / Soft: 62 / 36 N m
Dimensions (L x W x H)	198x79x249 mm
Net weight	1.8 kg

Standard Equipment: (+)(-) bit, Belt clip

AVAILABLE VARIANTS		
5.0Ah	3.0Ah	"Z" VARIANT
DHP482 RTJ INCLUDES 2 BATTERIES / 1 CHARGER / PLASTIC CARRYING CASE	-	DHP482 Z TOOL ONLY (DOES NOT INCLUDE BATTERY / CHARGER OR CARRYING CASE)

DHP484 13mm Acc Pg. A024-060

18V LXT - Lithium-Ion Cordless Percussion Driver Drill



Powerful Brushless motor & Compact and ergonomic design

- Delivers more drilling, driving and fastening speed
- Aluminum gear housing creates an impression of rigidity and luxuriousness
- Variable 2-speed for a wide range of drilling and fastening applications
- Built-in twin LED lights with pre-glow and afterglow functions illuminate the work area

Specifications:-

Capacity	Masonry / Steel / Wood: 13 / 13 / 38 mm
Chuck capacity	1.5 - 13 mm
Impacts per minute (ipm)	High / Low: 0 - 30,000 / 0 - 7,500
No Load Speed (RPM)	High / Low: 0 - 2,000 / 0 - 500
Max Fastening Torque	Hard / Soft: 54 / 30 N m
Dimensions (L x W x H)	182x79x261 mm
Net weight	1.9 kg

Standard Equipment: (+)(-) bit, Belt clip

AVAILABLE VARIANTS		
5.0Ah	3.0Ah	"Z" VARIANT
DHP484 RTJ INCLUDES 2 BATTERIES / 1 CHARGER / PLASTIC CARRYING CASE	DHP484 RFJ INCLUDES 2 BATTERIES / 1 CHARGER / PLASTIC CARRYING CASE	DHP484 Z TOOL ONLY (DOES NOT INCLUDE BATTERY / CHARGER OR CARRYING CASE)

DHP453 13mm Acc Pg. A024-060

18V LXT - Lithium-Ion Cordless Percussion Driver Drill



All metal gear construction ensures high transmission durability.

- Single sleeve keyless chuck enables easy bit installation/removal with one hand.
- Ergonomically designed rubberized soft grip provides more control and comfort.

Specifications:-

Capacity	Steel / Wood / Masonry: 13 / 36 / 13 mm
Chuck capacity	1.5 - 13 mm
Impacts Per Minute (IPM)	Hi : 0-19,500 Lo : 0-6,000
No Load Speed (RPM)	Hi : 0-1,300 Lo : 0-400
Max Fastening Torque	Hard / Soft : 42 / 27N m
Dimensions (L x W x H)	239x79x244mm
Net weight	2.0kg

Standard Equipment: (+)(-) bit, Belt clip

AVAILABLE VARIANTS		
5.0Ah	3.0Ah	"Z" VARIANT
-	DHP453 RFE INCLUDES 2 BATTERIES / 1 CHARGER / PLASTIC CARRYING CASE	

DHP483 13mm Acc Pg. A024-060

18V LXT - Lithium-Ion Cordless Percussion Driver Drill



New Ultra-compact and ergonomic design at only 176mm long and lightweight for reduced operator fatigue

- Brushless motor provides higher power and productivity
- Variable 2-speed for a wide range of drilling and fastening applications

Specifications:-

Capacity	Steel / Wood / Masonry: 13 / 36 / 13 mm
Chuck capacity	1.5 - 13 mm
Impacts Per Minute (IPM)	High / Low: 0 - 25,500 / 0 - 7,500
No Load Speed (RPM)	High / Low: 0 - 1,700 / 0 - 500
Max Fastening Torque	Hard / Soft: 40 / 23 N m
Dimensions (L x W x H)	176x79x247 mm
Net weight	1.6 kg

Standard Equipment: (+)(-) bit, Belt clip

AVAILABLE VARIANTS		
5.0Ah	3.0Ah	"Z" VARIANT
DHP483 RTJ INCLUDES 2 BATTERIES / 1 CHARGER / MAKPAC CONNECTOR CASE	DHP483 RFJ INCLUDES 2 BATTERIES / 1 CHARGER / MAKPAC CONNECTOR CASE	DHP483 Z TOOL ONLY (DOES NOT INCLUDE BATTERY / CHARGER / CARRYING CASE)

18V LXT - LITHIUM-ION CORDLESS PERCUSSION DRIVER DRILL - COMPARISON CHART

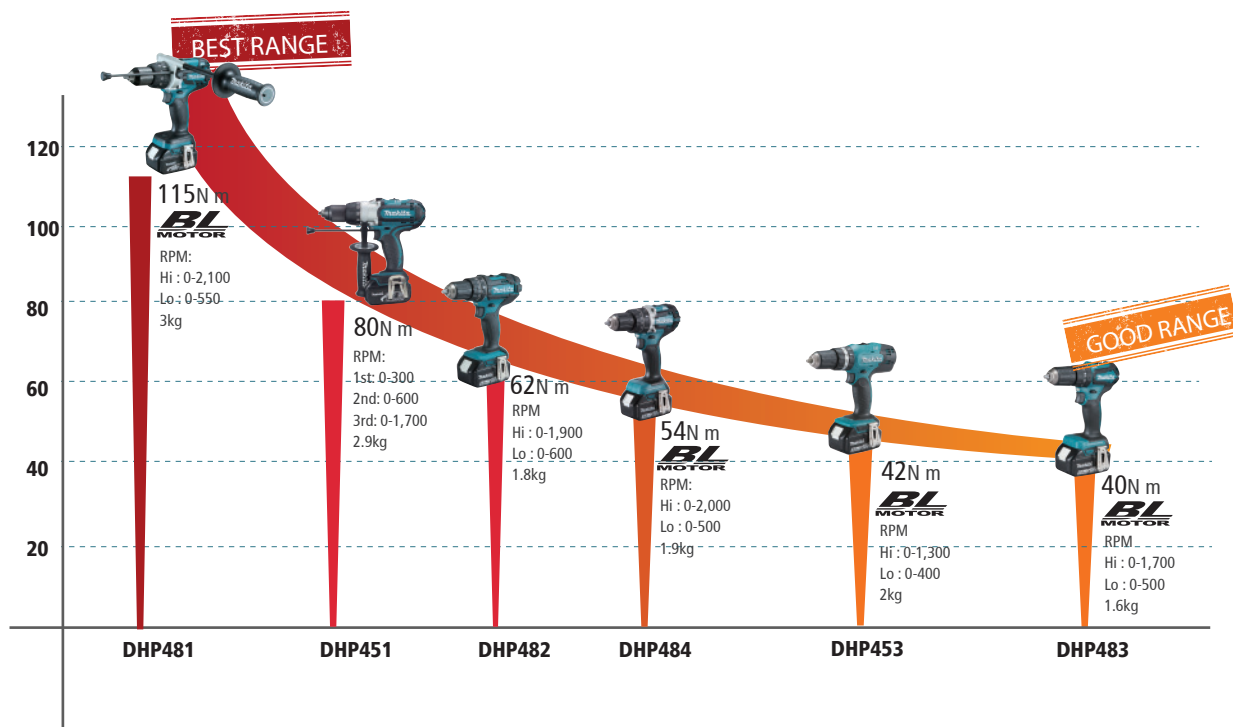

- CORDLESS
- FIXING / FASTENING
- DRILLING / IMPACT DRILLING
- CONCRETE DRILLING / DEMOLITION
- CUTTING [CONCRETE/ MASONRY/ METAL]
- MULTI TOOL
- GRINDING
- SANDING / POLISHING
- SAWING
- ROUTERING / PLANING
- CLEANING
- HEAT GUN / LASERS
- PNEUMATIC TOOLS
- GARDEN TOOLS
- GENERATORS

- CORDLESS
- FIXING / FASTENING
- DRILLING / IMPACT DRILLING
- CONCRETE DRILLING / DEMOLITION
- CUTTING [CONCRETE/ MASONRY/ METAL]
- MULTI TOOL
- GRINDING
- SANDING / POLISHING
- SAWING
- ROUTERING / PLANING
- CLEANING
- HEAT GUN / LASERS
- PNEUMATIC TOOLS
- GARDEN TOOLS
- GENERATORS

DTD171
Acc Pg. A024-031

18V LXT - Lithium-Ion Cordless Impact Driver

BL MOTOR **XPT**

More compact & Higher efficiency achieved by using BL motor

- Shortest body + Well balanced
- Twin LED job light with preglow and afterglow functions

8

tightening modes for various applications

4

Changing the impact force (panel button)

4

Assist mode (panel button)

Wood Tightening long screws. (0 - 3,800 / 3,800)

Bolt Loosening bolts. (0 - 3,600 / 3,600)

T1 Teks screw thin metal. Loosening self-drilling screws for a thin metal like a metal stud.

T2 Teks screw thick metal. Loosening self-drilling screws for a thick metal plate with good finish.

Enhanced Anvil holder rigidity

Material change from Needle bearing to Ball bearing provides reduction of bit wobbling

Quick mode-switching function

Impact force change with one hand The level of impact force changes every time you press the quick mode-switching button while holding the grip.

Max tightening torque

180 N·m

Memory function of impact mode is equipped

If any two modes are registered in advance, you can switch to your desired mode by just pressing quick mode-switching button.

Specifications:-

Machine screw :	M4 - M8 (5/32" - 5/16")
Standard bolt :	M5 - M16 (3/16" - 5/8")
High tensile bolt :	M5 - M14 (3/16" - 9/16")
Coarse thread (in length):	22 - 125mm (7/8" - 4-7/8")
Hex Shank	6.35mm (1/4")
Impacts Per Minute (ipm)	Max: 0 - 3,800 / Hard: 0 - 3,600 / Medium: 0 - 2,600 / Soft: 0 - 1,100 Wood: 0-3,800 / Bolt: 0-3,800 / T(2) mode: 0-2,600
No Load Speed (rpm)	Max: 0 - 3,600 / Hard: 0 - 3,200 / Medium: 0 - 2,100 / Soft: 0 - 1,100 Wood: 0-1,800 / Bolt: 0-3,600 / T(2) mode: 0-2,900 / T(2) mode: 0-3,600
Max tightening torque	180N.m
Dimensions (L x W x H)	116x79x236 mm
Net weight	1.6kg

Standard Equipments: Belt Clip

AVAILABLE VARIANTS		
5.0Ah	3.0Ah	"Z" VARIANT
DTD171 RTJ INCLUDES 2 BATTERIES / 1 CHARGER / MAKPAC CONNECTOR CASE	DTD171 RFJ INCLUDES 2 BATTERIES / 1 CHARGER / MAKPAC CONNECTOR CASE	DTD171 Z TOOL ONLY (DOES NOT INCLUDE BATTERY / CHARGER OR CARRY CASE)

DTD154
Acc Pg. A024-031

18V LXT - Lithium-Ion Cordless Impact Driver

BL MOTOR **XPT**

ULTRA-COMPACT and ergonomic design at only 117 mm long

- High performance with newly developed Brushless DC motor.
- Aluminum hammer case creates the impression of rigidity of the machine
- Dual LED lights with preglow / afterglow functions illuminate the work area
- 3 stage impact power selection plus T-mode function

Specifications:-

Machine screw :	M4 - M8 (5/32" - 5/16")
Standard bolt :	M5 - M16 (3/16" - 5/8")
High tensile bolt :	M5 - M14 (3/16" - 9/16")
Coarse thread (in length):	22 - 125 mm (7/8" - 4-7/8")
Hex Shank	6.35 mm (1/4")
No load speed (rpm)	0 - 3,600 / 0 - 2,100 / 0 - 1,100
Impacts per minute (ipm)	0 - 3,800 / 0 - 2,600 / 0 - 1,100
Max. fastening torque	175 N m
Dimensions (L x W x H)	117x79x236 mm
Net Weight	1.6 kg

Standard Equipments: Belt Clip

AVAILABLE VARIANTS		
5.0Ah	3.0Ah	"Z" VARIANT
DTD154 RTJ INCLUDES 2 BATTERIES / 1 CHARGER / MAKPAC CONNECTOR CASE	DTD154 RFJ INCLUDES 2 BATTERIES / 1 CHARGER / MAKPAC CONNECTOR CASE	DTD154 Z TOOL ONLY (DOES NOT INCLUDE BATTERY / CHARGER / CARRY CASE)

DTD153
Acc Pg. A024-031

18V LXT - Lithium-Ion Cordless Impact Driver

BL MOTOR **XPT**

Compact and lightweight design

- High performance with newly developed Brushless DC motor.
- Aluminum hammer case creates the impression of rigidity of the machine
- Dual LED lights with preglow / afterglow functions illuminate the work area

Specifications:-

Machine screw :	M4 - M8 (5/32" - 5/16")
Standard bolt :	M5 - M16 (3/16" - 5/8")
High tensile bolt :	M5 - M14 (3/16" - 9/16")
Coarse thread (in length):	22 - 125 mm (7/8" - 4-7/8")
Hex Shank	6.35 mm (1/4")
No load speed (rpm)	0 - 3,400
Impacts per minute (ipm)	0 - 3,600
Max. fastening torque	170 N m
Dimensions (L x W x H)	126x79x238 mm
Net Weight	1.6 kg

Standard Equipments: Belt Clip

AVAILABLE VARIANTS		
5.0Ah	3.0Ah	"Z" VARIANT
DTD153 RTJ INCLUDES 2 BATTERIES / 1 CHARGER / MAKPAC CONNECTOR CASE	DTD153 RFJ INCLUDES 2 BATTERIES / 1 CHARGER / MAKPAC CONNECTOR CASE	DTD153 Z TOOL ONLY (DOES NOT INCLUDE BATTERY / CHARGER / CARRY CASE)

DTP141

Acc Pg. A024-031

18V LXT - Lithium-Ion Cordless 4 Mode Impact Driver



More compact design achieved by using BLDC motor and electronic clutch mechanism.

- 4 Operation modes and Teks screw mode selection.
- Electronic Clutch Mechanism provides expanded torque range.
- Easier mode selection and higher durability of the selection mechanism.

Impact driver (3-speed)
High speed fastening of bolts and screws



Impact drill (2-speed)
Drilling pilot holes in Masonry



Drill (2-speed)
Drilling holes in wood and metal



Screwdriver (2-speed)
Driving small diameter screws



Specifications:-



Capacity	Steel: 10mm, Wood: 21mm Masonry: 8mm
Impacts per minute (ipm)	Impact-driver mode (Hard/Medium/Soft): 0-3,200/0-2,400/0-1,200
No load speed (rpm)	Hammer drill mode (Hi/L0): 0-32,400/0-8,400
	Impact-driver mode (Hard/Medium/Soft): 0-2,700/0-2,200/0-1,300
	Drill mode (Hi / Lo) : 0-2,700 / 0-700
	Hammer drill mode (Hi / Lo) : 0-2,700 / 0-700
Max. fastening torque	Impact-driver mode: 150N.m
	Drill mode : 22 / 13N.m
Dimensions (L x W x H)	171 x 79 x 250mm
Net Weight	1.8kg

AVAILABLE VARIANTS

5.0Ah	3.0Ah	"Z" VARIANT
	DTP141 RFJ INCLUDES 2 BATTERIES / 1 CHARGER / MAKPAC CONNECTOR CASE	DTP141 Z TOOL ONLY (DOES NOT INCLUDE BATTERY / CHARGER OR CARRY CASE)

DTS141

Acc Pg. A024-031

18V LXT - Lithium-Ion Cordless Oil-Pulse Driver



More compact and lightweight thanks to the newly-developed oil unit and brushless motor

- Incredibly low noise operation thanks to the impact mechanism using oil unit instead of anvil and hammer.
- "T" mode: Tightening mode for self-drilling screw and bolts.
- With the cooling system for oil unit, capable of long continuous operation.

World's Shortest & Lightest among Cordless Oil-pulse Driver



SOFT IMPACT Low Noise **77dB**

Using newly-developed Oil Unit as an impact mechanism instead of anvil and hammer, operation noise has been greatly reduced compared with cordless impact driver

Specifications:-



Capacity	Machine screw : M4 - M8 (5/32" - 5/16") Standard bolt : M5 - M8 (3/16" - 5/16") High strength bolt : M5 - M6 (3/16" - 1/4") Coarse thread (in length): 22 - 125mm (7/8" - 4-7/8")
Impacts per minute (ipm)	Hard :0-2,700 Medium :0-2,200 Soft :0-1,400
No load speed (rpm)	Hard :0-3,200 Medium :0-2,000 Soft :0-1,200
Max fastening torque	40N m
Dimensions (L x W x H)	136x79x240mm
Net weight	1.2kg

AVAILABLE VARIANTS

5.0Ah	3.0Ah	"Z" VARIANT
DTS141 RTJ INCLUDES 2 BATTERIES / 1 CHARGER / MAKPAC CONNECTOR CASE	DTS141 RFJ INCLUDES 2 BATTERIES / 1 CHARGER / MAKPAC CONNECTOR CASE	DTS141 Z TOOL ONLY (DOES NOT INCLUDE BATTERY / CHARGER OR CARRY CASE)

CORDLESS

FIXING / FASTENING

DRILLING / IMPACT DRILLING

CONCRETE DRILLING / DEMOLITION

CUTTING [CONCRETE/ MASONRY/ METAL]

MULTI TOOL

GRINDING

SANDING / POLISHING

SAWING

ROUTERING / PLANING

CLEANING

HEAT GUN / LASERS

PNEUMATIC TOOLS

GARDEN TOOLS

GENERATORS

CORDLESS
FIXING / FASTENING
DRILLING / IMPACT DRILLING
CONCRETE DRILLING / DEMOLITION
CUTTING [CONCRETE/ MASONRY/ METAL]
MULTI TOOL
GRINDING
SANDING / POLISHING
SAWING
ROUTERING / PLANING
CLEANING
HEAT GUN / LASERS
PNEUMATIC TOOLS
GARDEN TOOLS
GENERATORS

DTW1001 3/4" (19mm)
Acc Pg. A032-036

18V LXT - Lithium-Ion Cordless Impact Wrench

Excellent Performance as powerful as AC model with highly enhanced Brushless DC motor.

- Twin LED job light with preglow and afterglow functions
- Hammer case securely fastened with four bolts
- Variable speed control by trigger
- Easy-to-operate, push button type F/R change switch
- Best possible ergonomic handle

Extra-high maximum tightening torque 1,050N·m

High power BL motor and new impact mechanism

DTW1001 1,050N·m
Cordless Impact wrench (3/4")

229mm

3.7kg

Compact & lightweight

TW1000 1,000N·m
Corded Impact wrench (1")

382mm

8.4kg

153mm shorter
4.7kg lighter

Electronic 3 stage impact power selection

In order to reduce incorrect tightening, hard/medium/soft impact power can be selected to the material of workpiece or screw type simply by pushing a button.

Hard

Medium

Soft

Specifications:-

Fastening Capacities	Standard Bolt: M12 - M30 (1/2" - 1-1/4")
	High Tensile Bolt: M10 - M24 (3/8" - 1")
Square Drive	19 mm (3/4")
No Load Speed (RPM)	Hard / Medium / Soft: 0 - 1,800 / 0 - 1,000 / 0 - 900
Impacts Per Minute (IPM)	Hard / Medium / Soft: 0 - 2,200 / 0 - 2,000 / 0 - 1,800
Max Fastening Torque	1,050 N m
Dimensions (L x W x H)	229x91x289 mm
Net weight	3.7 kg

Specialized Accessories

Earth Auger Drill Bit for 3/4" Impact Wrench (DTW1001 / TW001G)

These auger bits are suitable for installing wooden/metal poles on the ground for preparing Greenhouse or farming. These drill bits can also be used for installing fence for camping sites and fixing poles in desert camp areas

Size	Type	Part no:
20mm dia x 600mm long	with 3/4" Socket, Pin & O ring	B-54302
25mm dia x 600mm long	with 3/4" Socket, Pin & O ring	B-54318
30mm dia x 600mm long	with 3/4" Socket, Pin & O ring	B-54324
35mm dia x 600mm long	with 3/4" Socket, Pin & O ring	B-54330
40mm dia x 600mm long	with 3/4" Socket, Pin & O ring	B-57576

DTW450 1/2" (12.7mm)
Acc Pg. A032-036

18V LXT - Lithium-Ion Cordless Impact Wrench

Delivers 440 N·m of torque for tough jobs

- Top no load speed 1,600 RPM creates 2,200 IPM
- Powerful DC motor with replaceable carbon brush for economic repair and maintenance
- Compact and lightweight design provide superior balance and control
- Large rocker switch for more convenience and comfort

Specifications:-

Fastening Capacities	Standard Bolt: M12 - M22 (1/2" - 7/8")
	High Tensile Bolt: M12 - M16 (1/2" - 5/8")
Square Drive	12.7 mm (1/2")
No Load Speed (RPM)	1,600
Impacts Per Minute (IPM)	2,200
Max Fastening Torque	440 N m
Dimensions (L x W x H)	266x82x290mm
Net weight	3.4 kg

Standard Equipments: Belt Clip

AVAILABLE VARIANTS		
5.0Ah	3.0Ah	"Z" VARIANT
-	-	DTW450 Z TOOL ONLY (DOES NOT INCLUDE BATTERY / CHARGER OR CARRY CASE)

DTW701 1/2" (12.7mm)
Acc Pg. A032-036

18V LXT - Lithium-Ion Cordless Impact Wrench

High Performance with Brushless Motor

- Features a forward and reverse automatic stop function, with 6 modes optimised for fastening applications
- A maximum tightening torque of 700 N·m
- Compact design with a short overall length of 170 mm
- Electronic 4 stage impact power selection
- Unique rubber joint suppress vibration to battery terminals

Specifications:-

Fastening Capacities	Standard Bolt: M10 - M24
	High Tensile Bolt: M10 - M16
Square Drive	12.7 mm (1/2")
No Load Speed (RPM)	0 - 2,200 / 0-1,900 / 0-1,200 / 0-500
Impacts Per Minute (IPM)	0-2,700 / 0-2,400ipm / 0-1,700 / 0-1,000
Max Fastening Torque	700 N m
Dimensions (L x W x H)	170 X 81 X 276 mm
Net weight	2.7kg

Specifications:-

AVAILABLE VARIANTS		
5.0Ah	3.0Ah	"Z" VARIANT
DTW701 RTJ INCLUDES 2 BATTERIES / 1 CHARGER / MAKPAC CONNECTOR CASE	-	DTW701 Z TOOL ONLY (DOES NOT INCLUDE BATTERY / CHARGER OR CARRY CASE)

DTW300 1/2" (12.7mm) Acc Pg. A032-036

18V LXT - Lithium-Ion Cordless Impact Wrench



High Performance with Brushless Motor

- Features a forward and reverse automatic stop function, with 6 modes optimised for fastening applications
- A maximum tightening torque of 330 N.m
- Compact design with a short overall length of 144 mm
- Electronic 4 stage impact power selection



Specifications:-



Fastening Capacities	Standard Bolt: M10 - M20 High Strength Bolt: M10 - M16
Square Drive	12.7 mm (1/2")
No Load Speed (RPM)	0-3,200/0-1,700/0-1,300/0-1,000
Impacts Per Minute (IPM)	0-4,000/0-2,200/0-1,700/0-1,300
Max Fastening Torque	330 N m (240 ft.lbs.)
Dimensions (L x W x H)	144x81x246 mm
Net weight	1.8 kg

AVAILABLE VARIANTS

5.0Ah	3.0Ah	"Z" VARIANT
DTW300 RTJ INCLUDES 2 BATTERIES / 1 CHARGER / MAKPAC CONNECTOR CASE	-	DTW300 Z TOOL ONLY (DOES NOT INCLUDE BATTERY / CHARGER OR CARRY CASE)

DTW285 1/2" (12.7mm) Acc Pg. A032-036

18V LXT - Lithium-Ion Cordless Impact Wrench



High Performance with Brushless Motor

- Reverse Rotation Auto Stop Mode Stops Rotation and Impact in 0.2 Seconds when Fastener Is Loosened Adequately to Prevent Bolt/Nut Get Lost
- A maximum tightening torque of 280 N.m
- Compact design with a short overall length of 147 mm
- Electronic 3 stage impact power selection.

Specifications:-



Fastening Capacities	Standard Bolt: M10 - M20 (3/8" - 3/4") High Tensile Bolt: M10 - M16 (3/8" - 5/8")
Square Drive	12.7 mm (1/2")
No Load Speed (RPM)	Hard / Medium / Soft: 0 - 2,800 / 0 - 2,100 / 0 - 1,600
Impacts Per Minute (IPM)	Hard / Medium / Soft: 0 - 3,500 / 0 - 2,600 / 0 - 1,800
Max Fastening Torque	280 N m
Dimensions (L x W x H)	147x79x249 mm
Net weight	1.8 kg

AVAILABLE VARIANTS

6.0Ah	5.0Ah	3.0Ah	"Z" VARIANT
DTW285 RGJ INCLUDES 2 BATTERIES / 1 CHARGER / MAKPAC CONNECTOR CASE	DTW285 RTJ INCLUDES 2 BATTERIES / 1 CHARGER / MAKPAC CONNECTOR CASE	DTW285 RFJ INCLUDES 2 BATTERIES / 1 CHARGER / MAKPAC CONNECTOR CASE	DTW285 Z TOOL ONLY (DOES NOT INCLUDE BATTERY / CHARGER OR CARRY CASE)



CORDLESS

FIXING / FASTENING

DRILLING / IMPACT DRILLING

CONCRETE DRILLING / DEMOLITION

CUTTING [CONCRETE/ MASONRY/ METAL]

MULTI TOOL

GRINDING

SANDING / POLISHING

SAWING

ROUTERING / PLANING

CLEANING

HEAT GUN / LASERS

PNEUMATIC TOOLS

GARDEN TOOLS

GENERATORS

- CORDLESS
- FIXING / FASTENING
- DRILLING / IMPACT DRILLING
- CONCRETE DRILLING / DEMOLITION
- CUTTING [CONCRETE/ MASONRY/ METAL]
- MULTI TOOL
- GRINDING
- SANDING / POLISHING
- SAWING
- ROUTERING / PLANING
- CLEANING
- HEAT GUN / LASERS
- PNEUMATIC TOOLS
- GARDEN TOOLS
- GENERATORS

DTW181 1/2" (12.7mm) Acc Pg. A032-036

18V LXT - Lithium-Ion Cordless Impact Wrench



Ultra-compact and ergonomic design with Brushless motor

- Reverse Rotation Auto Stop Mode Stops Rotation and Impact in 0.2 Seconds when Fastener Is Loosened Adequately to Prevent Bolt/Nut Get Lost
- A maximum tightening torque of 210 N.m
- Compact design with a short overall length of 151 mm
- Electronic 3 stage impact power selection.

Specifications:-

Capacity	Standard bolt : M8 - M16 (5/16" - 5/8") High strength bolt : M16 - M12 (1/4" - 1/2") Square drive : 12.7mm (1/2")
Impacts per minute (ipm)	Hard: 0 - 3,600 / Soft: 0 - 2,000
No load speed (rpm)	Hard: 0 - 2,400 / Soft: 0 - 1,300
Max fastening torque	210N m
Dimensions (L x W x H)	151x79x235mm
Net weight	1.5kg

AVAILABLE VARIANTS

5.0Ah	3.0Ah	"Z" VARIANT
DTW181 RTJ INCLUDES 2 BATTERIES / 1 CHARGER / MAKPAC CONNECTOR CASE		DTW181 Z TOOL ONLY (DOES NOT INCLUDE BATTERY / CHARGER OR CARRY CASE)

DTW190 1/2" (12.7mm) Acc Pg. A032-036

18V LXT - Lithium-Ion Cordless Impact Wrench



Light weight impact wrench.

- Ideal for scaffolding
- Max tightening torque: 190N.m.

Specifications:-

Capacity	Standard bolt : M8 - M16 (5/16" - 5/8") High strength bolt : M8 - M12 (5/16" - 1/2") Square drive : 12.7mm (1/2")
Impacts per minute (ipm)	3000
No load speed (rpm)	2300
Max fastening torque	190N m
Dimensions (L x W x H)	176x79x219mm
Net weight	1.4kg

AVAILABLE VARIANTS

5.0Ah	3.0Ah	"Z" VARIANT
	DTW190 RFJ INCLUDES 2 BATTERIES / 1 CHARGER / MAKPAC CONNECTOR CASE	DTW190 Z TOOL ONLY (DOES NOT INCLUDE BATTERY / CHARGER OR CARRY CASE)

18V LXT - Lithium-Ion Cordless Impact Wrench Comparison Chart

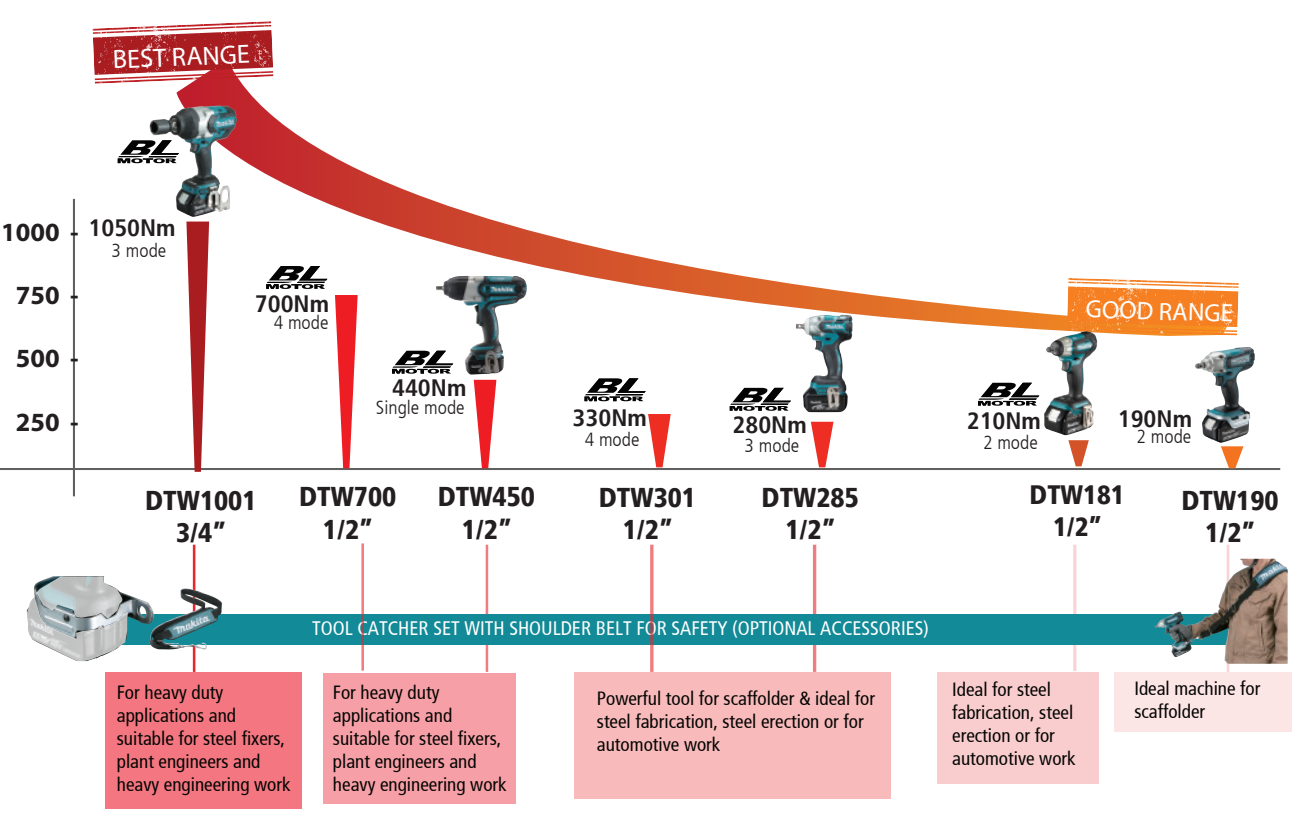

DDA351 10mm (3/8") Acc Pg. A024-060 **440** 

18V LXT - Lithium-ion Cordless Angle Drill



Compact angle head with small head height.

- Original 4-pole motor for power, lightweight and compact size.
- LED job light with afterglow function.
- Ergonomically designed rubberized soft grip.
- Easy-to-operate large type (paddle type) switch trigger.
- Single sleeve keyless chuck enables easy bit installation / removal by one hand.

Specifications:- 

Capacity	Steel : 10mm (3/8") Wood : 25mm (1")
No load speed (rpm)	0-1,800
Dimensions (L x W x H)	326x79x115mm
Net weight	1.9kg

Standard Equipment: Side grip.

AVAILABLE VARIANTS		
5.0Ah	3.0Ah	"Z" VARIANT
-	DDA351 RFE INCLUDES 2 BATTERIES / 1 CHARGER / PLASTIC CARRYING CASE	DDA351 Z TOOL ONLY (DOES NOT INCLUDE BATTERY / CHARGER OR CARRY CASE)

DUT130 Acc Pg. A057

18V LXT - Lithium-ion Cordless Mixer



Cordless Li-ion Mixer with Brushless Motor

- Variable 2-speed transmission (0-350 & 0-1,300 RPM) for a wide range of applications
- Variable speed trigger allows operator to adjust speed based on materials or application
- Suitable for mixer paddles up to Ø165 mm (6-1/2") with a M12 or M14 thread

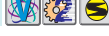
Specifications:- 

Blade Diameter	165 mm (6-1/2")
No Load Speed (RPM)	High / Low: 0 - 1,300 / 0 - 350
Dimensions (L x W x H)	w/ Mixing Blade: 920x89x231 mm w/o Mixing Blade: 323x89x231 mm
Net weight	2.8 kg

Standard Equipment: Mixing Blade, Shaft, Grip, Wrenches



TOOL BAG ONLY WITH DUT130 RTE

AVAILABLE VARIANTS		
5.0Ah	3.0Ah	"Z" VARIANT
DUT130 RTE INCLUDES 2 BATTERIES / 1 CHARGER and tool bag		DUT130 Z TOOL ONLY (DOES NOT INCLUDE BATTERY / CHARGER OR CARRY CASE)

DFS452 Acc Pg. A024-031

18V LXT - Lithium-ion Cordless Screwdriver



Ultra-high efficiency comparable to AC screwdrivers

- Push Drive Technology - in lock-on mode the motor starts only when the fastener is engaged for a quieter work environment and to save battery power
- BL motor for better performance
- eXtreme Protection Technology (XPT) is engineered for improved dust and water resistance for operation in harsh conditions

Specifications:- 

Capacity	Self-Drilling Screw: 6 mm (1/4") Drywall Screw: 5 mm (3/16")
Driving Shank (Hex)	6.35 mm (1/4")
No Load Speed (RPM)	0 - 4,000
Vibration Level	Screwdriving w/o Impact: 2.5 m/s ² or less
Sound Pressure Level	72 dB(A)
Dimensions (L x W x H)	251x79x259 mm (10"x3-1/8"x11-1/4")
Net weight	1.8 kg

Standard Equipment: 1 Phillips Bit + Magnetic connect Bit.

AVAILABLE VARIANTS		
5.0Ah	3.0Ah	"Z" VARIANT
DFS452 RTJ INCLUDES 2 BATTERIES / 1 CHARGER / MAKPAC CONNECTOR CASE	DFS452 RFJ INCLUDES 2 BATTERIES / 1 CHARGER / MAKPAC CONNECTOR CASE	DFS452 Z TOOL ONLY (DOES NOT INCLUDE BATTERY / CHARGER OR CARRY CASE)

DFS250 Acc Pg. A024-031

18V LXT - Lithium-ion Cordless Screwdriver



Ultra-high efficiency comparable to AC screwdrivers

- High torque ideal for decking applications
- Push Drive Technology - in lock-on mode the motor starts only when the fastener is engaged for a quieter work environment and to save battery power
- BL motor for better performance

Specifications:- 

Capacity	Coarse Thread: 4.5 x 90 mm (3/16" x 3-1/2") Drywall Screw: 5 mm (3/16") Self-Drilling Screw: 6 mm (1/4")
Driving Shank (Hex)	6.35 mm (1/4")
No Load Speed (RPM)	0 - 2,500
Vibration Level	Screwdriving w/o Impact: 2.5 m/s ² or less
Sound Pressure Level	72 dB(A)
Dimensions (L x W x H)	259x79x259 mm
Net weight	1.9 kg

Standard Equipment: 1 Phillips Bit + Magnetic connect Bit.

AVAILABLE VARIANTS		
5.0Ah	3.0Ah	"Z" VARIANT
		DFS250 Z TOOL ONLY (DOES NOT INCLUDE BATTERY / CHARGER OR CARRY CASE)

- CORDLESS
- FIXING / FASTENING
- DRILLING / IMPACT DRILLING
- CONCRETE DRILLING / DEMOLITION
- CUTTING [CONCRETE/ MASONRY/ METAL]
- MULTI TOOL
- GRINDING
- SANDING / POLISHING
- SAWING
- ROUTERING / PLANING
- CLEANING
- HEAT GUN / LASERS
- PNEUMATIC TOOLS
- GARDEN TOOLS
- GENERATORS

- CORDLESS
- FIXING / FASTENING
- DRILLING / IMPACT DRILLING
- CONCRETE DRILLING / DEMOLITION
- CUTTING [CONCRETE/ MASONRY/ METAL]
- MULTI TOOL
- GRINDING
- SANDING / POLISHING
- SAWING
- ROUTERING / PLANING
- CLEANING
- HEAT GUN / LASERS
- PNEUMATIC TOOLS
- GARDEN TOOLS
- GENERATORS

Acc Pg. A031 **440**mm

DFR550

18V LXT - Lithium-ion Cordless Auto Feed Screwdriver



More reliable sturdy aluminium casing attachment

- Stopper base provides anti-tilt device for preventing screws from swaying.
- Silent clutch features high durability.
- Screw guide designed to prevent collated screw strip from getting tangled.
- Reverse switch operable by one hand.

Specifications:-

Capacity	Drywall screw : 4x25 - 55mm (5/32"x1" - 2-3/16")
Bit size	Hex Shank : 6.35mm (1/4")
No load speed (rpm)	4,000
Dimensions (L x W x H)	424x80x238mm (16-3/4"x3-1/8"x9-3/8")
Net weight	2.1kg



Standard Equipment: Phillips bit.

AVAILABLE VARIANTS

5.0Ah	3.0Ah	"Z" VARIANT
-	DFR550 RFE INCLUDES 2 BATTERIES / 1 CHARGER / PLASTIC CASE	DFR550 Z TOOL ONLY (DOES NOT INCLUDE BATTERY / CHARGER OR CARRY CASE)

DRV150

18V LXT - Lithium-ion Cordless Rivet Gun

Cordless Li-ion Rivet Gun with Brushless Motor

- Fastens Ø4.8 - Ø2.4 Blind Rivets
- Compact center height for increased maneuverability against a wall
- Rivet retention function
- Transparent mandrel container

Specifications:-

Max pulling force	10 kN
Length of Stroke	25 mm (1")
Dimensions (L x W x H)	310x80x287 mm
Net weight	2.2 kg

Standard Equipment: Belt Clip

AVAILABLE VARIANTS

5.0Ah	3.0Ah	"Z" VARIANT
-	DRV150 RFJ INCLUDES 2 BATTERIES / 1 CHARGER / PLASTIC CASE	DRV150 ZJ TOOL ONLY (WITH MAKPAK CASE) (DOES NOT INCLUDE BATTERY / CHARGER)

DRV150 - Accessories

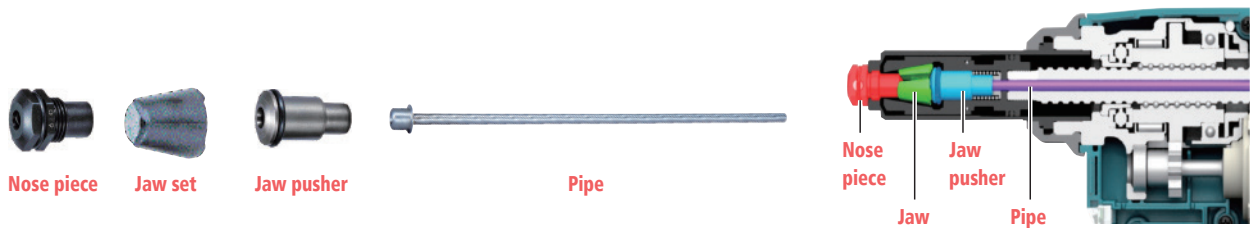

Model - DRV150	
Rivet	Size
	Mandrel diameter: mm
Nose piece and Jaw pusher set *with pipe	Size
	Part No.
Jaw set (3pcs set)	Size
	Part No.

	Ø2.4 mm	Ø3.2 mm	Ø4.0 mm	Ø4.8 mm
Mandrel diameter: mm	Ø1.4 mm - 1.6 mm	Ø1.8 mm - 2.1 mm	Ø2.2 mm - 2.6 mm	Ø1.4 mm - 1.6 mm
Size	Ø2.4 mm	Ø3.2 mm	Ø4.0 mm	Ø4.8 mm
Part No.	*199729-4	*199728-6	191C04-2	*191C03-4
Size	4.8 mm			
Part No.	199731-7			

Grease set (5g)

Jaw grease for maintenance (Grease to jaw case & jaws)
Molybdenum disulfide grease **191D57-7**



DSC121

18V LXT - Lithium-ion Cordless Threaded Rod Cutter



High cutting power and speed achieved by BL motor



Powerful BL motor
Cuts M12 steel threaded rod in 3 seconds

Balance stand
helps you cut thread horizontally



Accessories

Cutter blade set



Clean cut surface

Burr-free cuts allow for easy nut tightening.



Type	Size	Part no:
Mild Steel - Stainless Steel	M12	SC09002720
Mild Steel - Stainless Steel	M10	SC09002710
Mild Steel - Stainless Steel	M8	SC09002700

Specifications:-



Capacity	Steel: 8 - 12 mm (5/16" - 1/2")
Cutting Speed (sec)	3.0
Vibration Level	2.5 m/s ² or less
Sound Pressure Level	85 dB(A)
Sound Power Level	96 dB(A)
Dimensions (L x W x H)	212x323x260 mm
Net weight	6.0 kg

Standard Equipment: Hex Wrench

AVAILABLE VARIANTS

5.0Ah	3.0Ah	"Z" VARIANT
-	-	DSC121 ZK TOOL + CARRYCASE ONLY (DOES NOT INCLUDE BATTERY / CHARGER)

DSC102

18V LXT - Lithium-ion Cordless Threaded Rod Cutter



More Compact & High Productivity with brushless motor

- Lightweight provides increased comfort for overhead cutting
- No spark, no deburring required and low noise
- Nut can be immediately mounted.
- Compatible with both 18V and 14.4V LXT Li-Ion batteries



Compact motor section with overall length of **177mm**



Excellent tool balance allows for operation with less wrist fatigue.

Performs stable cutting even on the floor



Rod guide

There are two rod guide positions.



◀ [1]
Size of threaded rod
W8/3, M10



◀ [2]
Size of threaded rod
M8, M6

Accessories

Long life cutter blade



High rigidity
Double-edged blade

Clean cut surface

Burr-free cuts allow for easy nut tightening.



Type	Size	Part no:
Mild Steel - Stainless Steel	M6	199087-8
Mild Steel - Stainless Steel	M8	199085-2
Mild Steel	M10	199083-6

Specifications:-



Capacity	Steel: M6 - M10 mm (W3/8")
Vibration Level	cutting threaded stainless steel rod (rod size W3/8): 2.5 m/s ² or less
Dimensions (L x W x H)	199x103x308 mm
Net weight	3.3 kg

Standard Equipment: Depth Gauge, Hex Wrench,

AVAILABLE VARIANTS

5.0Ah	3.0Ah	"Z" VARIANT
-	-	DSC102 ZI TOOL + MANKPACK CASE ONLY (DOES NOT INCLUDE BATTERY / CHARGER)

CORDLESS

FIXING / FASTENING

DRILLING / IMPACT DRILLING

CONCRETE DRILLING / DEMOLITION

CUTTING [CONCRETE/ MASONRY/ METAL]

MULTI TOOL

GRINDING

SANDING / POLISHING

SAWING

ROUTERING / PLANING

CLEANING

HEAT GUN / LASERS

PNEUMATIC TOOLS

GARDEN TOOLS

GENERATORS

- CORDLESS
- FIXING / FASTENING
- DRILLING / IMPACT DRILLING
- CONCRETE DRILLING / DEMOLITION
- CUTTING [CONCRETE/ MASONRY/ METAL]
- MULTI TOOL
- GRINDING
- SANDING / POLISHING
- SAWING
- ROUTERING / PLANING
- CLEANING
- HEAT GUN / LASERS
- PNEUMATIC TOOLS
- GARDEN TOOLS
- GENERATORS

DSC163

18V LXT - Lithium-ion Cordless Steel Rod Cutter



Brushless Motor for faster rebar cutting

- Quick and effortless rebar cutting for maximum jobsite productivity and safety
- Spark free cutting, Ideal for cutting steel bars laid in concrete slab
- Up to 150 cuts of 20 mm rebar with a 6.0Ah LXT battery
- Cutting capacity range of 3 - 20 mm standard rebar
- 4-Way rotatable cutting blade provides up to 4,000 cuts before needing to be replaced
- Cutting head rotates 360° to accommodate different cutting positions.



Accessories



Type	Part no:
Cutter blade set	SC09002470

Specifications:-



Capacity	Dia: 3 - 16 mm
Cutting Speed (sec)	2.8 sec
Dimensions (L x W x H)	360x108x276 mm
Net weight	6.9 kg

Standard Equipment: Wrench, Hex Wrench

AVAILABLE VARIANTS		
5.0Ah	3.0Ah	"Z" VARIANT
-	-	DSC163 ZK TOOL + CARRY CASE (DOES NOT INCLUDE BATTERY / CHARGER)

DSC250 / DSC251

18V LXT - Lithium-ion Cordless Steel Rod Cutter



Ideal for edge cutting of threaded rods and rebars

- Fine edge cutting: Rebars can be cut at 3.5 mm from the corner of lattice for both vertically and horizontally;
- Threaded rods can be cut also at 3.5 mm from the ground/surface
- Less damage to the threaded rods and therefore nuts can be installed without removing burrs
- ADT (Automatic Torque Drive Technology) adjusts speed and torque during operation for optimum performance
- High power with Brushless Motor
- Flangeless blade can be equipped (DSC251)

Excellent edge cutting 3.5mm from the ground/surface

Smooth Nut mounting without deburring



Accessories



For Model	Type	Size	Part no:
DSC251	TCT Saw Blade	110mm	SC09003260

Spacer part # SC09030550 used with DSC250 to fit the above accessory

Specifications:-

Blade Diameter	110 mm
Cutting Capacity	Dia.: 10 - 25 mm
No Load Speed (RPM)	2,200
Vibration Level	Cutting Rebar: 2.5 m/s ² or less
Dimensions (L x W x H)	471x137x139 mm
Net weight	4.0 kg

Standard Equipment: Side Grip, Hex Wrench

AVAILABLE VARIANTS		
5.0Ah	3.0Ah	"Z" VARIANT
-	-	DSC250 ZK DSC251 ZK TOOL + CARRY CASE (DOES NOT INCLUDE BATTERY / CHARGER)

DPP200

Acc Pg. A086

18V LXT - Lithium-ion Cordless Hole Puncher



Automatic punch return
Automatic punch return: After a punching cycle is completed, hydraulic pressure automatically pulls off the punch from workpiece and returns it to the initial position to enable efficient continuous hole punching

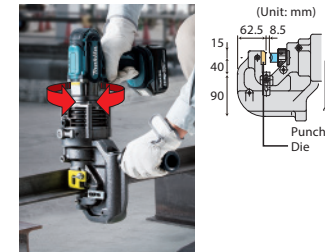

More reliable sturdy aluminium casing attachment

- Punches up to 20 mm holes through steel plate up to 8 mm thick
- Versatile punch is applicable to a variety of materials: mild steel, stainless steel, channel, aluminium and copper.
- Provides high-speed punching of round/oblong holes through structural steels such as flat bar, angle or channel.

Specifications:-

Capacity	Steel: 20 mm (13/16") Stainless Steel: 20 mm (13/16")
Max Throat Depth	40 mm (1-9/16")
Dimensions (L x W x H)	417x127x315 mm
Net weight	10.5 kg

Standard Equipment: Hex Wrench, Spanner, Bar for fastening nuts, Grip

AVAILABLE VARIANTS		
5.0Ah	3.0Ah	"Z" VARIANT
		DPP200 ZK TOOL ONLY + CARRY CASE (DOES NOT INCLUDE BATTERY / CHARGER)

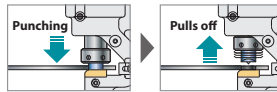

Flat bar



Max: 80mm x t8
(Center punching)

Angle



Min: 40mm x 40mm x t3
Max: 80mm x 80mm x t8

Channel



Min: 75mm x 40mm
Max: 100mm x 50mm
Flat Punching

Accessories

Work stand
SC03801080



Slide stopper
SC03300790



Hydraulic Oil
SC00000106
35mL



Hydraulic Oil
SC00000270
1,000mL



CORDLESS

FIXING / FASTENING

DRILLING / IMPACT DRILLING

CONCRETE DRILLING / DEMOLITION

CUTTING [CONCRETE/ MASONRY/ METAL]

MULTI TOOL

GRINDING

SANDING / POLISHING

SAWING

ROUTERING / PLANING

CLEANING

HEAT GUN / LASERS

PNEUMATIC TOOLS

GARDEN TOOLS

GENERATORS

- CORDLESS
- FIXING / FASTENING
- DRILLING / IMPACT DRILLING
- CONCRETE DRILLING / DEMOLITION
- CUTTING [CONCRETE/ MASONRY/ METAL]
- MULTI TOOL
- GRINDING
- SANDING / POLISHING
- SAWING
- ROUTERING / PLANING
- CLEANING
- HEAT GUN / LASERS
- PNEUMATIC TOOLS
- GARDEN TOOLS
- GENERATORS

DTR180

18V LXT - Lithium-ion Cordless Rebar Tying Tool



Tying times per 1 charge*
about **5,300** times

1 Reel*
about **120** times

* D10 x D10, 2pcs of rebars, Battery : BL1850B



Employed to deliver the power to twist tie wire

Easier and faster sequential rebar tying

Continuous actuation mode

Hold the trigger and pull the contact plate against rebars



Compact and slim design

Enable to use in narrow areas

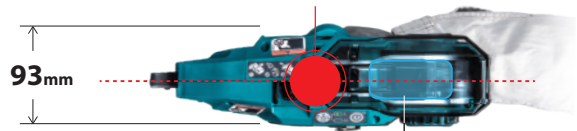

Easy to load with tie wire reel

Selectable 2-Modes



Single actuation
↕
Continuous actuation

Applicable rebars:
10mmx1pc X 10mmx1pc to 13mmx2pcs X 13mmx2pcs



Adjustable rebar tying strength

According to the condition of tying material, tying strength can be adjusted in 6 stages.



	Tying capacity (2 pcs of rebars)		
	10mm	13mm	16mm
10mm	✓	✓	✓
13mm	✓	✓	✓
16mm	✓	✓	✓

	Tying capacity (3 pcs of rebars)	
	10mm x 10mm	13mm x 13mm
10mm	✓	✓
13mm	✓	✓
16mm	✓	-

	Tying capacity (4 pcs of rebars)	
	10mm x 10mm	13mm x 13mm
10mm x 10mm	✓	✓
13mm x 13mm	✓	✓

Specifications:-



Tie Wire	ø0.8 mm
Applicable Rebars	#10x1pc X #10x1pc to #13x2pcs X #13x2pcs
Vibration Level	2.5 m/s ² or less
Sound Pressure Level	78 dB(A)
Dimensions (L x W x H)	304x93x318 mm
Net weight	2.6 kg

Standard Equipment: Hex Wrench, Hook

AVAILABLE VARIANTS

5.0Ah	3.0Ah	"Z" VARIANT
-	-	DTR180 ZJ TOOL ONLY (WITH MAKPAC CASE) (DOES NOT INCLUDE BATTERY / CHARGER)

Accessories



Tie wire set
Diameter: 0.8mm
Length: 100m
Pack: 50 pcs/ box
Part No. 199137-9

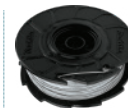

Galvanized Tie wire set
Strong and rust free
Diameter: 0.8mm
Length: 100m
Pack: 50 pcs/ box
Part No. 191A57-9

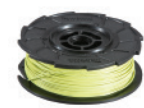

Poly-Coated Tie Wire
Ideal for tying epoxy-coated rebar
Diameter: 0.8mm
Length: 100m
Pack: 50 pcs/ box
Part No. 191J59-9



DCS553 150mm (5-7/8")

Acc Pg. A081-082

18V LXT - Lithium-ion Cordless Metal Cutter



The 150mm diameter blade enables single-pass cutting of a 2-inch inner diameter metal pipe (outer diameter: 55.8mm)

- Built-in dust collection box for cleaner work environment
- Metal chip/dust can be thrown away by just opening the dust box cap
- Increased speed (4,200 RPM) provides more comfortable operation for light load application
- Cuts 51 mm (2") conduit in a single pass

Specifications:-



Blade Diameter	150 mm (5-7/8")
Max Cutting Capacity	90°: 57.5 mm (2-1/4")
No Load Speed (RPM)	4,200
Vibration Level	Cutting Metal: 2.5 m/s ² or less
Sound Pressure Level	103 dB(A)
Sound Power Level	114 dB(A)
Dimensions (L x W x H)	267x186x250 mm (10-1/2"x7-3/8"x9-7/8")
Net weight	3.1 kg

Standard Equipment: TCT Saw Blade, Hex Wrench, Safety Goggles, Guide Rule

AVAILABLE VARIANTS

5.0Ah	3.0Ah	"Z" VARIANT
-	-	DCS553 Z TOOL ONLY (DOES NOT INCLUDE BATTERY / CHARGER OR CARRY CASE)

Compact design

Overall length of the tool has been greatly shortened by relocating battery



Predecessor Model DCS551
332mm

267mm

65mm Shortened

Large depth adjusting lever

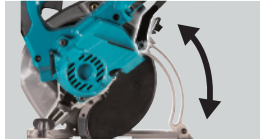

Easy disposal of dust by simply opening Dust cap



Accessories

TCT Saw Blade for Cordless Metal Cutter



Blade Dia (mm)	Suitable for Models	(Bore) Hole dia. (mm)	(Kerf) Tip Thickness (mm)	Hook Angle (deg)	No. of teeth	Tooth Shape	Material / Application	Type	Part No.
136	DCS550	20	1.5	0	30	MTCG	Mild steel	-	B-07319
150	DCS553	20	1.1	0	33		Metal	EFFICUT Metal	B-69440
150	DCS553	20	1.1	0	48		Metal & SUS	EFFICUT Metal	B-69456
150	DCS553	20	1.5	0	32	MTCG	Mild steel	-	B-46296
150	DCS553	20	1.1	0	60	SMTCG	Stainless/Mild steel	Laser Slit	B-47014

Carbide-Tipped Metal Blades for Many Applications with Metal Cutter DCS553 / DCS551

PART NO.	SIZE (MM)	MATERIAL	PIPE		CHANNEL		TUBING		METAL SHEET
			STEEL	STAINLESS STEEL	STEEL	STAINLESS STEEL	STEEL	STAINLESS STEEL	STAINLESS STEEL
			ø25 t=1.2mm	40x45mm t=1.6mm	40x45mm t=1.6mm	30x30mm t=1.5mm	30x30mm t=1.5mm		t=1.5mm
B-46296	150mm x 32T		●	●	✕	●	✕		✕
B-47014	150mm x 60T (CERMET TIP)		✕	✕	○	✕	●		●

CORDLESS

FIXING / FASTENING

DRILLING / IMPACT DRILLING

CONCRETE DRILLING / DEMOLITION

CUTTING [CONCRETE/ MASONRY/ METAL]

MULTI TOOL

GRINDING

SANDING / POLISHING

SAWING

ROUTERING / PLANING

CLEANING

HEAT GUN / LASERS

PNEUMATIC TOOLS

GARDEN TOOLS

GENERATORS

CORDLESS
FIXING / FASTENING
DRILLING / IMPACT DRILLING
CONCRETE DRILLING / DEMOLITION
CUTTING [CONCRETE/ MASONRY/ METAL]
MULTI TOOL
GRINDING
SANDING / POLISHING
SAWING
ROUTERING / PLANING
CLEANING
HEAT GUN / LASERS
PNEUMATIC TOOLS
GARDEN TOOLS
GENERATORS

DPB183 Acc Pg. A084

18V LXT - Lithium-ion Cordless Portable Band Saw



High power & Compact design due to brushless motor. Stable cutting with highly rigid aluminium structure

- Constant speed control minimizes the reduction in blade speed to provide stable cutting
- Easy blade track adjustment simply by turning the screw
- Lightweight design with excellent balance
- Easy installation / removal of blade
- Variable speed control by dial
- Catch bracket protects the tool body from damage by hitting against workpiece.

Specifications:-

Capacity	Round: 66 mm Square: 66 x 66 mm
Blade Speed	0 - 3.2 m/s
Blade Size	Length: 835 mm / Width: 13 mm / Thickness: 0.5 mm
Dimensions (L x W x H)	392x174x242 mm
Net weight	3.9 kg

Standard Equipment: Hex wrench

AVAILABLE VARIANTS		
5.0Ah	3.0Ah	"Z" VARIANT
-	-	DPB183 Z TOOL ONLY (DOES NOT INCLUDE BATTERY / CHARGER OR CARRY CASE)

DPB182 Acc Pg. A084

18V LXT - Lithium-ion Cordless Portable Band Saw



Stable cutting with highly rigid aluminium structure

- Firm cutting
- Blade orbital can be easily adjusted from outside
- Lightweight design with excellent balance
- Easy blade replacement by quick blade tension release/stretch with large lever
- Easy-to-grip handle with elastomer surface for anti-slip

Specifications:-

Capacity	Round: 64 mm Rectangular workpiece w/o stand : 64x64 mm
Blade speed	3.2 m/s
Dimensions (L x W x H)	477x197x229 mm
Net weight	4.0 kg

Standard Equipment: Hex wrench

AVAILABLE VARIANTS		
5.0Ah	3.0Ah	"Z" VARIANT
-	-	DPB182 Z TOOL ONLY (DOES NOT INCLUDE BATTERY / CHARGER OR CARRY CASE)

DPB181 Acc Pg. A084

18V LXT - Lithium-ion Cordless Portable Band Saw



Lightweight design with excellent balance.

- Easy blade replacement by quick blade tension release/stretch with large lever.
- Adjustable stopper plate.
- Easy-to-grip handle with elastomer surface for anti-slip.

Specifications:-

Capacity	Round workpiece (dia) : 64mm (2-1/2") Rectangular workpiece Without stand : 64x64mm (2-1/2"x2-1/2")
Blade speed	3.2m/s (630ft/min.)
Dimensions (L x W x H)	468x197x233mm (18-1/2"x7-3/4"x9-1/8")
Net weight	3.2kg

Standard Equipment: Hex wrench

AVAILABLE VARIANTS		
5.0Ah	3.0Ah	"Z" VARIANT
-	-	DPB181 Z TOOL ONLY (DOES NOT INCLUDE BATTERY / CHARGER OR CARRY CASE)

DPB180 Acc Pg. A084

18V LXT - Lithium-ion Cordless Portable Band Saw



Light weight and well balanced tool design.

- Electronic current limiter for overload protection (with Warning Lamp).
- Single-Light LED Job Light with afterglow function.
- Speed Preset Dial allows to adjust the blade speed to suit workpiece material or desired finish.
- Ergonomically designed handle with elastomer surface for anti-slip, firm grip.
- Bumper protects tool body when putting down on the floor.

Specifications:-

Capacity	Round workpiece (dia) : 120mm (4-3/4") Rectangular workpiece Without stand: 120x120mm (4-3/4"x4-3/4")
Blade speed	84m (275 ft) - 162m (530 ft) / min
Dimensions (L x W x H)	523x231x313mm (20-5/8"x9-1/8"x12-3/8")
Net weight	6.4kg

Standard Equipment: Hex wrench.

AVAILABLE VARIANTS		
5.0Ah	3.0Ah	"Z" VARIANT
-	-	DPB180 Z TOOL ONLY (DOES NOT INCLUDE BATTERY / CHARGER OR CARRY CASE)

Comparison Chart - Portable Band Saw

Model No.	DPB183	DPB182	DPB181	DPB180
Capacity: Square Pipe	66 mm	64 mm	64 mm	120 mm
Capacity: Round Pipe	66 mm	64 mm	64 mm	120 mm
Brushless Motor	√	X	X	X
Frame material	Aluminium	Aluminium	Plastic	Aluminium
Easy blade track adjustment	√	√	X	X
Constant speed control	√	X	X	X
Variable speed control	√	X	X	√



CORDLESS

FIXING / FASTENING

DRILLING / IMPACT DRILLING

CONCRETE DRILLING / DEMOLITION

CUTTING [CONCRETE/ MASONRY/ METAL]

MULTI TOOL

GRINDING

SANDING / POLISHING

SAWING

ROUTERING / PLANING

CLEANING

HEAT GUN / LASERS

PNEUMATIC TOOLS

GARDEN TOOLS

GENERATORS

Accessories

Portable Band Saw blades



For Model : DPB180

Blade type	WX L (mm)	Thickness (mm)	Thickness of work piece	Teeth Per Inch (TPI)	Application	Pcs per package	Part No.
Carbon steel	1140 x 13mm	0.5	- 14	6	Wood	3	792567-9
Carbon steel	1140 x 13mm	0.5	More than 5mm		Plastics and non ferrous metals. Mild steel, cast steel and cast iron	3	792560-3
Carbon steel	1140 x 13mm	0.5	4 - 5mm	18		3	792559-8
Carbon steel	1140 x 13mm	0.5	Less than 4mm	24		3	792558-0
Bi-Metal	1140 x 13mm	0.5	More than 5mm	14		1	792557-2
Bi-Metal	1140 x 13mm	0.5	4 - 5mm	18	Plastics and non ferrous metals. Mild steel, cast steel and cast iron. Hard steel and stainless steel	1	792556-4
Bi-Metal	1140 x 13mm	0.5	Less than 4mm	24 WAVE TEETH		1	194692-6

For Model: DPB181 / DPB182 / DPB183

Blade type	WX L (mm)	Thickness (mm)	Thickness of work piece	Teeth Per Inch (TPI)	Application	Pcs per package	Part No.
Bi-Metal	835 x 13mm	0.5	3mm-6 mm	14 WAVE TEETH	Plastics and non-ferrous metal. Mild steel, cast steel and cast iron. Hard steel and stainless steel.	5	B-40543
Bi-Metal	835 x 13mm	0.5	2 mm- 3 mm	18 WAVE TEETH		5	B-40559
Bi-Metal	835 x 13mm	0.5	less than 2mm	24 WAVE TEETH		5	B-40565

CORDLESS
FIXING / FASTENING
DRILLING / IMPACT DRILLING
CONCRETE DRILLING / DEMOLITION
CUTTING (CONCRETE/ MASONRY/ METAL)
MULTI TOOL
GRINDING
SANDING / POLISHING
SAWING
ROUTERING / PLANING
CLEANING
HEAT GUN / LASERS
PNEUMATIC TOOLS
GARDEN TOOLS
GENERATORS

DJS101 Acc Pg. A807 **430**

18V LXT - Lithium-ion Cordless Shear



High cutting capacity cordless 1.0mm metal shear

- Easy curve cutting
- Straight design provides more control and high maneuverability for easy cutting operation
- Minimum outside cutting radius of 30 mm for close right or left curve cuts with a smooth edge
- Anti-restart function with warning lamp

Specifications:-

Capacity	Steel up to 400 N/mm ² : 1.0 mm
	Steel up to 600 N/mm ² : 0.7 mm
	Aluminum up to 200 N/mm ² : 2.5 mm
Strokes Per Minute (SPM)	4,300
Dimensions (L x W x H)	364x78x118 mm
Net weight	2.2 kg

Standard Equipment: Hex Wrench

AVAILABLE VARIANTS

5.0Ah	3.0Ah	"Z" VARIANT
DJS101 RTJ INCLUDES 2 BATTERIES / 1 CHARGER / MAKIPAC CONNECTOR CASE		DJS101 Z TOOL ONLY (DOES NOT INCLUDE BATTERY / CHARGER OR CARRY CASE)

DJN161 Acc Pg. A807 **430**

18V LXT - Lithium-ion Cordless Nibbler



18v Li-ion Cordless 1.6 mm (16 Ga) Nibbler ideal for cutting roofing sheet metal at thicknesses up to 16 gauge

- Makita-built motor delivers 1,900 SPM for faster and smooth cutting
- Die holder rotates 360° to meet demands of cutting direction
- Convenient chip disposal is below cutting material to minimize damage to cutting surface
- Cutting radius: inner edge 45 mm (1-3/4"); outer 50 mm (2")

Specifications:-

Capacity	Mild Steel up to 400 N/mm ² : 1.6 mm
	Stainless Steel up to 600 N/mm ² : 1.2 mm
	Aluminum up to 200 N/mm ² : 2.5 mm
Min. cutting radius	Inside edge : 45 mm (1-3/4")
	Outside edge : 50 mm (2")
Strokes Per Minute (SPM)	1,900
Dimensions (L x W x H)	313x78x189 mm
Net weight	2.3 kg

Standard Equipment: Hex Wrench, Wrench, Punch, Die

AVAILABLE VARIANTS

5.0Ah	3.0Ah	"Z" VARIANT
-	DJN161 RFE INCLUDES 2 BATTERIES / 1 CHARGER / PLASTIC CASE	-

DTM51 Acc Pg. A089-098

18V LXT - Lithium-ion Cordless Multi Tool



Tool-less accessory clamp for quick installation and replacement.

- 12 angle setting of accessories at every 30° from 0° to 360°.
- Variable speed control by dial.
- Battery capacity warning lamp.
- Anti-restart function prevents accidental start-up.

Specifications:-

Oscillations per minute (opm)	6,000 - 20,000
Oscillation Angle	Left / Right / Total: 1.6° / 1.6° / 3.2°
Dimensions (L x W x H)	340x80x122 mm
Net weight	2.4 kg

Standard Equipment: Hex Wrench

Cutting PVC, FRP pipes



Sanding/polishing various materials



Scraping floor tiles



Routing joints on wall tiles



Corner cutting



Cutting tiles



Wood flush cutting



Wood plunge cutting



Deep plunge cutting



Metal flush cutting



Flush cutting of nails



Cutting polystyrene, rubber



Removing mortar, tile adhesive



Cutting plasterboards



Cutting metals



Cutting window putty silicone



AVAILABLE VARIANTS

5.0Ah	3.0Ah	"Z" VARIANT
DTM51 RTJ INCLUDES 2 BATTERIES / 1 CHARGER / MAKIPAC CONNECTOR CASE	DTM51 RFJ INCLUDES 2 BATTERIES / 1 CHARGER / MAKIPAC CONNECTOR CASE	DTM51 Z TOOL ONLY (DOES NOT INCLUDE BATTERY / CHARGER OR CARRY CASE)

Features 18V LXT - Lithium-ion Cordless Angle Grinders



ADT

Automatic torque Drive Technology automatically changes the cutting speed according to load conditions for an optimum operation

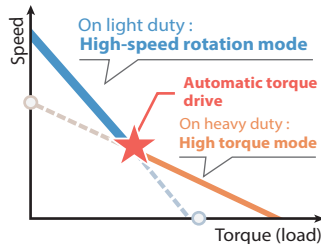

AFT

Active Feedback sensing Technology Shuts down the tool, if the rotation speed suddenly slows down.

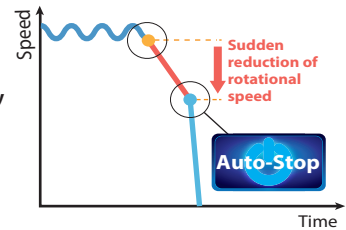

Electric brake

Enables you to start next operation quickly

Soft start

Minimizes start-up shock, and makes the tool start smoothly

Anti-restart function

Prevents accidental start-up

Product Comparison List

LXT Cordless Grinders	Size	BL Motor Brushless Motor	XPT Extreme Protection Technology	AFT Active Feedback sensing Technology	ADT Automatic torque driver technology	Anti-restart function	Brake	Switch Type	AWS	X-Lock	No load speed (rpm)
DGA901	230mm	✓	✓	✓	✓	✓	✓	Large trigger	✓	—	6,000
DGA900	230mm	✓	✓	✓	✓	✓	✓	Large trigger	—	—	6,000
DGA701	180mm	✓	✓	✓	✓	✓	✓	Large trigger	✓	—	7,800
DGA700	180mm	✓	✓	✓	✓	✓	✓	Large trigger	—	—	7,800
DGA519	125mm	✓	✓	✓	✓	✓	✓	Paddle	—	✓	3,000 - 8,500
DGA469	115mm	✓	✓	✓	✓	✓	✓	Paddle	—	✓	3,000 - 8,500
DGA458	115mm	✓	✓	✓	✓	✓	✓	Paddle	—	—	8,500
DGA456	115mm	✓	✓	✓	✓	✓	✓	Slide	—	—	8,500
DGA455	115mm	✓	✓	✓	✓	✓	—	Paddle	—	—	8,500
DGA454	115mm	✓	✓	✓	✓	✓	—	Slide	—	—	8,500
DGA452	115mm	—	—	—	—	✓	—	Slide	—	—	11,000

- CORDLESS
- FIXING / FASTENING
- DRILLING / IMPACT DRILLING
- CONCRETE DRILLING / DEMOLITION
- CUTTING [CONCRETE/ MASONRY/ METAL]
- MULTI TOOL
- GRINDING
- SANDING / POLISHING
- SAWING
- ROUTERING / PLANING
- CLEANING
- HEAT GUN / LASERS
- PNEUMATIC TOOLS
- GARDEN TOOLS
- GENERATORS

XLOCK

The X-Lock system allows for the tool-less installation and removal of X-Lock wheels in a single action. It minimizes down time and prevents overtightening of accessories.



Simply press to place



Pull the lever to release



DGA469 115mm (4-1/2") (Paddle Switch) Acc Pg. A112-128

18V LXT - Lithium-ion Cordless Angle Grinder

NEW

BL MOTOR XPT XLOCK ADT AFT

Safe and Quick fix in One Click with X-Lock system

- High Power with Brus/hless motor and Variable speed for the most demanding applications
- Paddle type on/off switch, Anti-restart function and Electric Brake.
- New tool-less wheel cover (Slide lever style for fast and easy angle adjustment and installation / removal of wheel cover

Specifications:- PADDLE SWITCH

Wheel Diameter	115 mm (4-1/2")
Hole Diameter	22.23 mm
No Load Speed (RPM)	3,000 - 8,500
Circumference of Grip Portion	160 mm
Vibration Level	Surface Grinding w/ Anti-Vibration Side Grip: 5.5 m/s ²
Sound Pressure Level	80 dB(A)
Dimensions (L x W x H)	396x130x147 mm
Net weight	3.1 kg

Standard Equipment: Lock nut wrench, Side grip.

5.0Ah	3.0Ah	"Z" VARIANT
		DGA469 Z TOOL ONLY (DOES NOT INCLUDE BATTERY / CHARGER OR CARRY CASE)

DGA519 125mm (5") (Paddle Switch) Acc Pg. A112-128

18V LXT - Lithium-ion Cordless Angle Grinder

NEW

BL MOTOR XPT XLOCK ADT AFT

Safe and Quick fix in One Click with X-Lock system

- High Power with Brus/hless motor and Variable speed for the most demanding applications
- Paddle type on/off switch, Anti-restart function and Electric Brake.
- New tool-less wheel cover (Slide lever style for fast and easy angle adjustment and installation / removal of wheel cover

Specifications:- PADDLE SWITCH

Wheel Diameter	125 mm (5")
Hole Diameter	22.23 mm
No Load Speed (RPM)	3,000 - 8,500
Circumference of Grip Portion	160 mm
Vibration Level	Surface Grinding w/ Anti-Vibration Side Grip: 7.0 m/s ²
Sound Pressure Level	80 dB(A)
Dimensions (L x W x H)	396x140x147 mm
Net weight	3.1 kg

Standard Equipment: Lock nut wrench, Side grip.



5.0Ah	3.0Ah	"Z" VARIANT
		DGA519 Z TOOL ONLY (DOES NOT INCLUDE BATTERY / CHARGER OR CARRY CASE)

Optional Accessories - X Lock Abrasive Wheels and Diamond Wheels

<div style="text-align: center;"> </div> <p>X-Lock Thin Cutting Wheels</p> <p>E-00418 125mm x 1.2mm x 22.23 mm Inox - Mild Steel</p> <hr/> <p>E-00387 115mm x 1.2mm x 22.23 mm Inox - Mild Steel</p>	<div style="text-align: center;"> </div> <p>X-Lock Grinding Wheels</p> <p>E-00393 125mm x 6mm x 22.23 mm For Metal</p> <hr/> <p>E-00365 115mm x 6mm x 22.23 mm For Metal</p>	<div style="text-align: center;"> </div> <p>X-Lock Diamond Wheel</p> <p>E-02060 115mm x 22.23mm Segmented Rim Concrete, Granite, Marble</p> <hr/> <p>E-02076 125mm x 22.23mm Segmented Rim Concrete, Granite, Marble</p>
---	---	---

DGA458 115mm (4-1/2") (Paddle Switch) Acc Pg. A101-128

18V LXT - Lithium-ion Cordless Angle Grinder

Excellent Performance as powerful as AC model with highly enhanced Brushless DC motor

- Paddle type on/off switch, Anti-restart function and Electric Brake.
- AFT function shuts down the tool, if the rotation speed suddenly slows down.
- Automatic speed control : Automatically changes the cutting speed according to load condition for an optimum operation. Handles heavy load with Excellent Cooling Function.
- High efficiency and More work amount by Brushless DC motor

Specifications:-  **PADDLE SWITCH**



Wheel diameter	115mm (4-1/2")
No load speed (rpm)	8,500
Dimensions (L x W x H)	362x130x151mm (14-1/4"x5-1/8"x5-15/16")
Net weight	2.6kg (5.8lbs)

Standard Equipment: Lock nut wrench, Side grip.

5.0Ah	3.0Ah	"Z" VARIANT
		DGA458 Z TOOL ONLY (DOES NOT INCLUDE BATTERY / CHARGER OR CARRY CASE)

DGA456 115mm (4-1/2") (Slide Switch) Acc Pg. A101-128

18V LXT - Lithium-ion Cordless Angle Grinder

Excellent Performance as powerful as AC model with highly enhanced Brushless DC motor

- Slide type on/off switch, Anti-restart function and Electric Brake.
- AFT function shuts down the tool, if the rotation speed suddenly slows down.
- Automatic speed control : Automatically changes the cutting speed according to load condition for an optimum operation. Handles heavy load with Excellent Cooling Function.
- High efficiency and More work amount by Brushless DC motor

Specifications:- 



Wheel diameter	115mm (4-1/2")
No load speed (rpm)	8,500
Dimensions (L x W x H)	362x130x151mm (14-1/4"x5-1/8"x5-15/16")
Net weight	2.6kg (5.7lbs)

Standard Equipment: Lock nut wrench, Side grip.

5.0Ah	3.0Ah	"Z" VARIANT
		DGA456 Z TOOL ONLY (DOES NOT INCLUDE BATTERY / CHARGER OR CARRY CASE)

DGA455 115mm (4-1/2") (Paddle Switch) Acc Pg. A112-128

18V LXT - Lithium-ion Cordless Angle Grinder

Excellent Performance as powerful as AC model with highly enhanced Brushless DC motor

- Paddle type on/off switch and Anti-restart function.
- AFT function shuts down the tool, if the rotation speed suddenly slows down.
- Automatic speed control : Automatically changes the cutting speed according to load condition for an optimum operation. Handles heavy load with Excellent Cooling Function.
- High efficiency and More work amount by Brushless DC motor.

Specifications:-  **PADDLE SWITCH**

Wheel diameter	115mm (4-1/2")
No load speed (rpm)	8,500
Dimensions (L x W x H)	362x130x145mm (14-1/4"x5-1/8"x5-3/4")
Net weight	2.5kg (5.6lbs)

Standard Equipment: Lock nut wrench, Side grip.

5.0Ah	3.0Ah	"Z" VARIANT
DGA455 RTJ INCLUDES 2 BATTERIES / 1 CHARGER / MAKPAC CONNECTOR CASE	DGA455 RFJ INCLUDES 2 BATTERIES / 1 CHARGER / MAKPAC CONNECTOR CASE	DGA455 Z TOOL ONLY (DOES NOT INCLUDE BATTERY / CHARGER OR CARRY CASE)

DGA454 115mm (4-1/2") (Slide Switch) Acc Pg. A112-128

18V LXT - Lithium-ion Cordless Angle Grinder



Excellent Performance as powerful as AC model with highly enhanced Brushless DC motor

- Slide type on/off switch and Anti-restart function.
- AFT function shuts down the tool, if the rotation speed suddenly slows down.
- Automatic speed control : Automatically changes the cutting speed according to load condition for an optimum operation. Handles heavy load with Excellent Cooling Function.
- High efficiency and More work amount by Brushless DC motor.

Specifications:- 

Wheel diameter	115mm (4-1/2")
No load speed (rpm)	8,500
Dimensions (L x W x H)	362x130x145mm (14-1/4"x5-1/8"x5-3/4")
Net weight	2.5kg (5.6lbs)

Standard Equipment: Lock nut wrench, Side grip.

5.0Ah	3.0Ah	"Z" VARIANT
DGA454 RTJ INCLUDES 2 BATTERIES / 1 CHARGER / MAKPAC CONNECTOR CASE	DGA454 RFJ INCLUDES 2 BATTERIES / 1 CHARGER / MAKPAC CONNECTOR CASE	DGA454 Z TOOL ONLY (DOES NOT INCLUDE BATTERY / CHARGER OR CARRY CASE)

CORDLESS

FIXING / FASTENING

DRILLING / IMPACT DRILLING

CONCRETE DRILLING / DEMOLITION

CUTTING [CONCRETE/ MASONRY/ METAL]

MULTI TOOL

GRINDING

SANDING / POLISHING

SAWING

ROUTERING / PLANING

CLEANING

HEAT GUN / LASERS

PNEUMATIC TOOLS

GARDEN TOOLS

GENERATORS

CORDLESS

FIXING / FASTENING

DRILLING / IMPACT DRILLING

CONCRETE DRILLING / DEMOLITION

CUTTING [CONCRETE/ MASONRY/ METAL]

MULTI TOOL

GRINDING

SANDING / POLISHING

SAWING

ROUTERING / PLANING

CLEANING

HEAT GUN / LASERS

PNEUMATIC TOOLS

GARDEN TOOLS

GENERATORS

DGA452 115mm (4-1/2") Acc Pg. A101-128 **430** 

18V LXT - Lithium-ion Cordless Angle Grinder



Powerful angle grinder now free from cord.

- Capable of using wheels / discs for AC Grinders.
- Easy-to-grip, small circumference motor housing.
- Anti-restart function for safety (with warning lamp).
- Electronic current limiter (with warning lamp).

Specifications:-

Wheel diameter	115mm (4-1/2")
No load speed (rpm)	11,000
Dimensions (L x W x H)	317x129x126mm (12-1/2"x5-1/8"x5")
Net weight	2.0kg (4.4lbs)

Standard Equipment: Lock nut wrench, Side grip.

AVAILABLE VARIANTS		
5.0Ah	3.0Ah	"Z" VARIANT
DGA452 RTJ 2 BATTERIES / 1 CHARGER IN MAKPAC CASE	DGA452 RFJ INCLUDES 2 BATTERIES / 1 CHARGER / MAKPAC CONNECTOR CASE	DGA452 Z TOOL ONLY (DOES NOT INCLUDE BATTERY / CHARGER OR CARRY CASE)

DGD800 Acc Pg. A124-125 **430** 

18V LXT - Lithium-ion Cordless Die Grinder



Now free from cord for easy job site portability.

- Long-nose type.
- Solid aluminum bearing box.
- Vent slots designed to direct exhaust air away from operator.
- Easy-to-grip motor housing with small circumference.

Specifications:-

Capacity	Collet : 3mm - 8mm
Wheel diameter	38mm (1-1/2")
No load speed (rpm)	26,000
Dimensions (L x W x H)	402x82x118mm (15-3/4"x3-1/4"x4-5/8")
Net weight	2.0kg (4.4lbs)

Standard Equipment: Wrench x 2pcs

AVAILABLE VARIANTS		
5.0Ah	3.0Ah	"Z" VARIANT
-	-	DGD800 Z TOOL ONLY (DOES NOT INCLUDE BATTERY / CHARGER OR CARRY CASE)

DPO600 150 mm (6") Acc Pg. A134-136

18V LXT - Lithium-ion Cordless Random Orbit Polisher



High power similar to AC tool achieved by High power Brushless Motor

- Selectable two rotation mode: normal mode for rough polishing & finishing mode for fine polishing

Rough Polishing

Forcible rotation mode

Orbital action with forced rotation of the pad for rough polishing such as scratch removal.



Fine Polishing

Free rotation mode

Orbital action with free rotation of the pad for fine polishing.

Specifications:-

Pad Size	150 mm (6")
Orbits Per Minute (OPM)	Normal mode: 0 - 6,800 / Finishing mode: 0 - 5,300
Strokes Per Minute (SPM)	Normal mode: 0 - 13,600 / Finishing mode: 0 - 10,600
No Load Speed (RPM)	Normal mode: 0 - 780 / Finishing mode: 0 - 610
Orbit Diameter	5.5 mm (7/32")
Dimensions (L x W x H)	530x123x128 mm
Net weight	3.6 kg

Standard Equipment: Rubber pad, grip

AVAILABLE VARIANTS		
5.0Ah	3.0Ah	"Z" VARIANT
DPO600 RTE 2 BATTERIES / 1 CHARGER / TOOL BAG	-	DPO600 Z TOOL ONLY (DOES NOT INCLUDE BATTERY / CHARGER OR TOOL BAG)

DBO180 125mm (5") Acc Pg. A133-139

18V LXT - Lithium-ion Cordless Random Orbit Sander



Excellent performance with high orbital speed.

- Compact design with a short height and a lower center of gravity easily handle.
- Excellent performance as powerful as AC model gives high productivity.
- Ergonomically best possible grip plus compact tool design.
- Connectable to Makita vacuum cleaners without adapter

Specifications:-

Pad diameter	123mm (4-7/8")
Abrasive disc diameter	125mm (5")
Orbits per minute (opm)	7,000/ 9,500/ 11,000
Dimensions (L x W x H)	175x123x153mm (6-7/8"x4-7/8"x6")
Net weight	1.7kg (3.6lbs)

Standard Equipment: Dust bag or dust box

AVAILABLE VARIANTS		
5.0Ah	3.0Ah	"Z" VARIANT
-	-	DBO180 Z TOOL ONLY (DOES NOT INCLUDE BATTERY / CHARGER OR CARRY CASE)

DSL800

Acc Pg. A133-134

18V LXT - Lithium-ion Cordless Drywall Sander



Continuous runtime
35min
Speed adjusting dial: 3
Abrasive discs: #120
Battery: BL1850B



Auto-start wireless system enables that the dust extractors runs automatically
Wireless unit 198900-7

Adjustable Pipe

The adjustable extension pipe for sanding in confined spaces, such as closets, and extends from 1,100mm to 1,520mm for reaching high walls and ceilings.

Direct Drive Brushless motor for increased efficiency

- Flush-to-wall edge sanding and Highly Flexible Head swivel
- A vacuum hose runs throughout the interior of the tool with a dust port at the base of the tool for use with a dust extractor for dust free sanding
- Overload sensor is designed to alert when excessive load is applied and protect from damage due to overheat

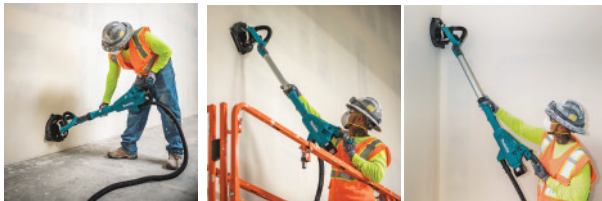

Accessories

Pad		Abrasive Disc 225mm		
Type	Part #	Grit	Pcs/Pkg	Part #
Soft	199939-3	40	25	B-68389
Medium	199940-8	80	25	B-68395
Hard	199938-5	120	25	B-68404
Brush and Roller		180	25	B-68410
Side Brush : 140J86-3		320	25	B-68426
Round Brush: 140J85-5				
Roller : 140L62-9				

Extension handle set (Optional)

Extension handle allows for an additional 570mm longer reach for sanding high walls and ceilings.
Part # 199937-7



Specifications:-

Pad diameter	210 mm
Abrasive Disc Size	225 mm
No Load Speed (RPM)	1,000 - 1,800
Sound Pressure Level	75 dB(A)
Vibration Level	2.5 m/s ² or less
Dimensions (L x W x H)	1,100-1,520x259x273 mm
Net weight	5.7 kg

Standard Equipment: Hex Wrench, Tool bag, Wireless Unit

AVAILABLE VARIANTS		
5.0Ah	3.0Ah	"Z" VARIANT
-	-	DSL800Z U TOOL ONLY + WIRELESS UNIT (DOES NOT INCLUDE BATTERY / CHARGER OR CARRY CASE)

DBS180

Acc Pg. A130 & 138

18V LXT - Lithium-ion Cordless Belt Sander



High power BL motor provides excellent performance similar to corded tool

- Compact design with a short height
- Excellent performance as powerful as AC model gives high productivity.
- Adjustable sanding arm 160° for easy handling
- Lightweight and Connectable to vacuum cleaners

Specifications:-

Belt Width	6 / 9 / 13 mm (1/4 / 3/8 / 1/2")
Belt Length	533 mm
Belt Speed	600 - 1,700 m/min
Vibration Level	2.5 m/s ² or less
Sound Pressure Level	77 dB(A)
Dimensions (L x W x H)	500x96x116 mm
Net weight	2.1 kg

Standard Equipment: Grip

AVAILABLE VARIANTS		
5.0Ah	3.0Ah	"Z" VARIANT
-	-	DBS180 Z TOOL ONLY (DOES NOT INCLUDE BATTERY / CHARGER OR CARRY CASE)

Sanding arm is angle adjustable to your needs.

0° -5°

-5° ◀▶ 90° [Stepless]

90°

Compact storage

160°

Anti-startup during storage

DBS180 is designed to minimize unexpected startup of the abrasive belt as long as the sanding arm is folded over 90°.

CORDLESS

FIXING / FASTENING

DRILLING / IMPACT DRILLING

CONCRETE DRILLING / DEMOLITION

CUTTING [CONCRETE / MASONRY / METAL]

MULTI TOOL

GRINDING

SANDING / POLISHING

SAWING

ROUTERING / PLANING

CLEANING

HEAT GUN / LASERS

PNEUMATIC TOOLS

GARDEN TOOLS

GENERATORS

CORDLESS
FIXING / FASTENING
DRILLING / IMPACT DRILLING
CONCRETE DRILLING / DEMOLITION
CUTTING [CONCRETE/ MASONRY/ METAL]
MULTI TOOL
GRINDING
SANDING / POLISHING
SAWING
ROUTERING / PLANING
CLEANING
HEAT GUN / LASERS
PNEUMATIC TOOLS
GARDEN TOOLS
GENERATORS

DLS600 165 mm (6-1/2") Acc Pg. A146

18V LXT - Lithium-ion Cordless Compound Miter Saw



High accuracy + Lightweight + Cordless

- Suitable for Cutting Baseboard and Ceiling Trim, etc.
- Compact and lightweight body provides excellent portability

Specifications:-

Blade Diameter	165 mm (6-1/2")
Miter Angle	52° L / 52° R
Bevel Angle	46° L / 46° R
Max Cutting Capacity	90° Miter: 46 x 92 mm
No Load Speed (RPM)	5,000
Dimensions (L x W x H)	340x400x440 mm
Net weight	6.6 kg

Standard Equipment: Vertical Vise, Hex Wrench, Triangular Rule

AVAILABLE VARIANTS		
5.0Ah	3.0Ah	"Z" VARIANT
-	-	DLS600 Z TOOL ONLY (DOES NOT INCLUDE BATTERY / CHARGER OR CARRY CASE)

High Accuracy
Excellent portability



Accessories
TCT Saw Blade for DLS600

Size (mm)	Plate (mm)	Kerf (mm)	Rake	Wood	Aluminum	Type	Part No.
165 x 20 x 64T	1.4	1.9	10	✓		-	B-56487
165 x 20 x 60T	1.2	1.8	5		✓	-	B-56530
165 x 20 x 60T	1.35	1.85	10	✓		EFFICUT	B-69892

DLS713 190mm (7-1/2") Acc Pg. A146-160 **441** MW

18V LXT - Lithium-ion Cordless Slide Compound Miter Saw



High Power but Compact

- Double sliding mechanism.
- Soft elastomer carrying grip provides easy job site portability.

Specifications:-

Max cutting capacity	at 0 degrees: 52 x 300mm (2-1/16" x 11-3/4") at 45 degrees: 25x 300mm (1" x 11-3/4")
Blade diameter	190mm (7-1/2")
Bore	20mm
No load speed (rpm)	2,200
Dimensions (L x W x H)	655 x 430 x 454mm
Net weight	12.7kg

Standard Equipment: Vertical Vise, Socket Wrench, Triangular Rule, Dust Bag, Holder set.

Accessories
TCT Saw Blade for DLS713 / DLS714

Size (mm)	Bore (mm)	Kerf (mm)	Rake	Teeth	Wood	Aluminum	Part No.
165 x 20 x 64T	20	2.0	10	72	✓		A-86359

AVAILABLE VARIANTS		
5.0Ah	3.0Ah	"Z" VARIANT
-	-	DLS713 Z TOOL ONLY (DOES NOT INCLUDE BATTERY / CHARGER OR CARRY CASE)

DHS680 165mm (6-1/2") Acc Pg. A143-160

18V LXT - Lithium-ion Cordless Circular Saw



High-efficiency Brushless motor provides higher power and more work amount.

- Compact and lightweight design.
- Automatic speed control : Automatically changes the cutting speed according to load condition for an optimum operation.
- Blower function blows sawdust off the cut line ahead for a better cutting view.
- Twin LED Job light.

Specifications:-

Max cutting capacity	at 0 degrees : 57mm (2-1/4") at 45 degrees : 41mm (1-5/8") at 50 degrees : 37mm (1-7/16")
Blade diameter	165mm (6-1/2")
No load speed (rpm)	5,000
Dimensions (L x W x H)	350x170x238mm (13-3/4"x6-11/16"x9-3/8")
Net weight	3.1kg (6.8lbs)

Standard Equipment: Hex wrench, Rip fence, Dust nozzle.

AVAILABLE VARIANTS		
DHS680 RTJ	DHS680 RFJ	DHS680 Z
INCLUDES 2 BATTERIES / 1 CHARGER / MAKPAC CONNECTOR CASE	INCLUDES 2 BATTERIES / 1 CHARGER / MAKPAC CONNECTOR CASE	TOOL ONLY (DOES NOT INCLUDE BATTERY / CHARGER OR CARRY CASE)

DHS660 / DHS661 165 mm (6-1/2")

Acc Pg. A143-160

18V LXT - Lithium-ion Cordless Circular Saw



Compact Design / Light weight

The new model is designed to shorten the overall length by relocating the position of the battery

Predecessor Model DHS661 / DHS660

350mm **270mm**

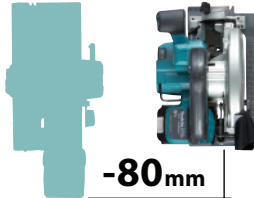

Brushless motor delivers 5,000 min-1 for better performance



Easy-to-operate lock-off push button
Improves the operability.

Better visibility of blade tip

Easy to see the tip of blade by changing the position of front grip

Indication lamp

- High torque mode: lights up in green
- High-speed rotation mode: lights out
- Overload alert: green light blinks

Twin LED Job light



Blower function



Specifications:-



	DHS660	DHS661
Blade Diameter	165 mm	165 mm
Hole Diameter	15.88 / 20 mm	15.88 / 20 mm
Max Cutting Capacity	90°: 57 mm	90°: 57 mm
	45°: 41 mm / 50°: 37 mm	45°: 41 mm / 50°: 37 mm
No Load Speed (RPM)	5,000	5,000
Vibration Level	Cutting Wood: 2.5 m/s ² or less	Cutting Wood: 2.5 m/s ² or less
Sound Pressure Level	93 dB(A)	93 dB(A)
Sound Power Level	104 dB(A)	104 dB(A)
Dimensions (L x W x H)	270x186x250 mm	270x186x250 mm
Net weight	3.2 kg	3.2 kg
AWS	X	✓

Standard Equipment: Hex wrench, Rip fence, Dust nozzle.

AVAILABLE VARIANTS

5.0Ah	3.0Ah	"Z" VARIANT
DHS660 RTJ INCLUDES 2 BATTERIES / 1 CHARGER / MAKAPAC CONNECTOR CASE		DHS660 Z TOOL ONLY (DOES NOT INCLUDE BATTERY / CHARGER OR CARRY CASE)
DHS661 RTJU INCLUDES 2 BATTERIES / 1 CHARGER / MAKAPAC CONNECTOR CASE + BLUETOOTH CHIP		DHS661 ZJU TOOL ONLY + BLUETOOTH CHIP + MAKAPAC CASE (DOES NOT INCLUDE BATTERY / CHARGER)

Scale
convenience to indicate such as saw blade position, cutting depth, bevel angle etc



Accessories - Efficut saw blades for DHS680 / DHS661 / DHS660



Size (mm)	(Bore) Hole dia. (mm)	(Kerf) Tip Thickness (mm)	Plate (mm)	Hook Angle (deg)	No. of teeth	Tooth Shape	Application	Part No.
165	20	1.45	1	23°	56	ATAFR	Wood / MDF	B-57364
165	20	1.40	1	23°	25	ATAFR	Wood	B-63018

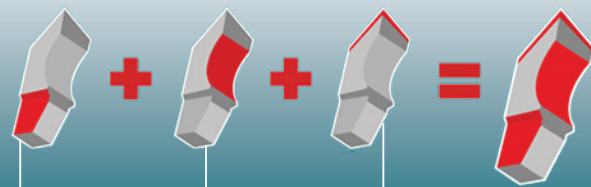

EFFICIENT SLIM TIP'S BOTTOM
reduces cutting resistance providing a longer runtime

EFFICIENT CURVED TIP'S BODY
allows excellent chip removal with reduced cutting resistance

EFFICIENT SHARP TIP'S TOP ANGLE
provides clear cutting with little effort

CORDLESS

FIXING / FASTENING

DRILLING / IMPACT DRILLING

CONCRETE DRILLING / DEMOLITION

CUTTING [CONCRETE/ MASONRY/ METAL]

MULTI TOOL

GRINDING

SANDING / POLISHING

SAWING

ROUTERING / PLANING

CLEANING

HEAT GUN / LASERS

PNEUMATIC TOOLS

GARDEN TOOLS

GENERATORS

CORDLESS
FIXING / FASTENING
DRILLING / IMPACT DRILLING
CONCRETE DRILLING / DEMOLITION
CUTTING [CONCRETE/ MASONRY/ METAL]
MULTI TOOL
GRINDING
SANDING / POLISHING
SAWING
ROUTERING / PLANING
CLEANING
HEAT GUN / LASERS
PNEUMATIC TOOLS
GARDEN TOOLS
GENERATORS

DSD180

18V LXT - Lithium-ion Cordless Drywall Cutter



Suitable for straight cut in overhead application, such as setting lights, air vents etc

- Smooth and powerful cutting at the high rotational speed of 3,700 rpm delivered from enhanced motor.
- Cutting depth can be adjusted to drywall thickness.
- V-notch in base plate helps easy tracing of cutting line.
- Blade cover protects drywall surfaces from damage/ scratches.



Specifications:-

Strokes Per Minute (SPM)	0- 6,000
Length of Stroke	6 mm (1/4")
Capacity	Drywall: 30mm (1-3/16") Wood: 15 mm (9/16")
Max Output	340W
Vibration Level	Cutting Drywall (thickness 30mm): 2.5 m/s ²
Sound Pressure Level	79 dB(A)
Dimensions (L x W x H)	263x79x291mm (10-3/8"x3-1/8"x11-3/8")
Net weight	1.9kg (4.2lbs)

Standard Equipment: Base cover, Hex Wrench

Accessories

	Suitable for Models	For Material	Part No
	DSD180, SD100D	Dry wall	B-49703
	DSD180, SD100D	Wood	B-49719

AVAILABLE VARIANTS		
5.0Ah	3.0Ah	"Z" VARIANT
-	-	DSD180 ZJ TOOL ONLY + OR MAKPAC CASE (DOES NOT INCLUDE BATTERY / CHARGER)

DJV180

Acc Pg. A152-161 **440**

18V LXT - Lithium-ion Cordless Jig Saw



High accuracy and high efficiency.

- Low vibration and low noise.
- Toolless push-in lock system enables extremely quick blade changes.
- Rubber Dust Seal at Rod and Retainer shuts out dust.
- Large trigger switch is easy to operate with gloved hand.
- Ergonomically designed handle with rubberized soft grip provides more control and comfort.

Specifications:-

Capacity	Wood : 135mm (5-5/16") Steel : 10mm (3/8")
Length of stroke	26mm (1")
Strokes per minute (spm)	0-2,600
Dimensions (L x W x H)	257x73x208mm (10-1/8"x2-7/8"x8-3/16")
Net weight	2.8kg (6.1lbs)

Standard Equipment: Cover Plate, Anti-Splintering Device, Hex Wrench.

AVAILABLE VARIANTS		
5.0Ah	3.0Ah	"Z" VARIANT
-	-	DJV180 Z TOOL ONLY (DOES NOT INCLUDE BATTERY / CHARGER OR CARRY CASE)

DJR187

Acc Pg. A156-157

18V LXT - Lithium-ion Cordless Reciprocating Saw



High efficiency and More work amount by Brushless DC motor

- Newly designed vertical crank mechanism
 - Minimizes blade deflection from aiming point especially in metal cutting
 - Reduces vibration of horizontal direction
- Electric 2 speed for wood / metal cutting
- Easy handling by redesigned blade clamp
- Ergonomically designed handle for better operation in every applications

Specifications:-

Capacity	Pipe : 130mm (5-1/8") Wood : 255mm (10")
Length of stroke	32mm (1-1/4")
Strokes per minute (spm)	Hi : 0-3,000 / Lo : 0-2,300
Dimensions (L x W x H)	439x83x230mm (17-1/4"x3-1/4"x9")
Net weight	3.4kg (7.6lbs)

AVAILABLE VARIANTS		
5.0Ah	3.0Ah	"Z" VARIANT
DJR187 RTE INCLUDES 2 BATTERIES / 1 CHARGER / PLASTIC CARRYING CASE	-	DJR187 Z TOOL ONLY (DOES NOT INCLUDE BATTERY / CHARGER OR CARRY CASE)

DJR181 Acc Pg. A156-157 **441**

18V LXT - Lithium-ion Cordless Reciprocating Saw



Extra high cutting speed model with large variable speed trigger.

- Tool-less blade change and tool-less shoe adjustment.
- Dust preventing air flow protects the front head mechanism.
- Best fit ergonomic grip shape for overhead application with gloved hand.
- Two-light type LED job light with afterglow function.
- With sky hook.

Specifications:- 

Capacity	Pipe : 130mm (5-1/8") Wood : 255mm (10")
Length of stroke	28mm (1-1/8")
Strokes per minute (spm)	0-2,900
Dimensions (L x W x H)	499x91x234mm (19-5/8"x3-5/8"x9-1/4")
Net weight	3.7kg (8.1lbs)

AVAILABLE VARIANTS

5.0Ah	3.0Ah	"Z" VARIANT
DJR181 RTE INCLUDES 2 BATTERIES / 1 CHARGER / PLASTIC CARRYING CASE	DJR181 RFE INCLUDES 2 BATTERIES / 1 CHARGER / PLASTIC CARRYING CASE	DJR181 Z TOOL ONLY (DOES NOT INCLUDE BATTERY / CHARGER OR CARRY CASE)

DJR185 Acc Pg. A156-157

18V LXT - Lithium-ion Cordless Reciprocating Saw



Two switch levers are available with variable speed control.

- Compact and lightweight handy body.
- Blade clamp compatible with both Recipro and Jig saw blades.
- LED job light with pre-glow function.

Specifications:- 

Capacity	Pipe : 50mm (2") Wood : 50mm (2")
Length of stroke	13mm (1/2")
Strokes per minute (spm)	0-3,000
Dimensions (L x W x H)	392x81x209mm (15-1/2"x3-3/16"x8-1/4")
Net weight	1.6kg (3.5lbs)

Standard Equipment: Hex wrench.

AVAILABLE VARIANTS

5.0Ah	3.0Ah	"Z" VARIANT
-	-	DJR185 Z TOOL ONLY (DOES NOT INCLUDE BATTERY / CHARGER OR CARRY CASE)

DRT50 Acc Pg. A163-181

18V LXT - Lithium-ion Cordless Router / Trimmer



Cordless for easy maneuverability and 4 different bases for added versatility













- Aluminum base for higher durability and accuracy
- Dual LED job lights illuminate cutting edge and increase visibility
- Connectable to Makita Vacuum Cleaner with dust nozzle for a cleaner work environment
- Can use the same accessories and attachments as AC model RT0700C

Specifications:- 

No Load Speed (RPM)	10,000 - 30,000
Plunge Capacity	with Trimmer Base: 0 - 40 mm with Plunge Base: 0 - 35 mm
Dimensions (L x W x H)	134x89x226 mm
Net weight	2.1 kg

Standard Equipment : Collet Cone, Trimmer Base Assembly, Straight Guide Assembly, Template Guide, Wrench x2, Trimmer Guide

DRT50ZJX9 comes with below accessories

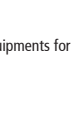
 DRT50Z - 18V Li-ion Cordless Trimmer with Trimmer base assembly (standard equipments for DRT50Z)	 Tilt base assembly 198985-3	 Plunge base assembly 195563-0	 Trimmer guide 122703-7 (standard equipments for DRT50Z)	 Straight guide 122391-0 (standard equipments for DRT50Z)
 Grip or plunge base assembly 153489-2	 Guide adapter set 194579-2	 Guide holder set 195564-8	 Dust nozzle for plunge base assembly 194733-8	 Dust Extracting Attachment, Fixed Base 195559-1 (standard equipments for DRT50Z)
 Template guide (standard equipments for DRT50Z)	 Collet cone (standard equipments for DRT50Z)	 Wrench x 2pcs (standard equipments for DRT50Z)		

AVAILABLE VARIANTS

5.0Ah	3.0Ah	"Z" VARIANT	WITH ACCESSORIES SET
		DRT50 Z TOOL ONLY (DOES NOT INCLUDE BATTERY / CHARGER OR CARRY CASE)	DRT50 ZJX9 TOOL ONLY + ACCESSORIES SET + MAKIPAC CASE (DOES NOT INCLUDE BATTERY / CHARGER)

- CORDLESS
- FIXING / FASTENING
- DRILLING / IMPACT DRILLING
- CONCRETE DRILLING / DEMOLITION
- CUTTING [CONCRETE/ MASONRY/ METAL]
- MULTI TOOL
- GRINDING
- SANDING / POLISHING
- SAWING
- ROUTERING / PLANING
- CLEANING
- HEAT GUN / LASERS
- PNEUMATIC TOOLS
- GARDEN TOOLS
- GENERATORS

- CORDLESS
- FIXING / FASTENING
- DRILLING / IMPACT DRILLING
- CONCRETE DRILLING / DEMOLITION
- CUTTING (CONCRETE/ MASONRY/ METAL)
- MULTI TOOL
- GRINDING
- SANDING / POLISHING
- SAWING
- ROUTERING / PLANING
- CLEANING
- HEAT GUN / LASERS
- PNEUMATIC TOOLS
- GARDEN TOOLS
- GENERATORS

DKP181 82mm (3-1/4") Acc Pg. A182-184

18V LXT - Lithium-ion Cordless Planer









High Power as AC Tool with BL Motor

- Auto-start Wireless System (AWS) connects to vacuum cleaner with Bluetooth
- Automatic torque Drive Technology (ADT) adjusts cutting speed and torque during cut for optimum performance
- Angle and shape of handle are easy to grip, push and carry.
- Precise planing depth setting by adjustment knob with click stops.
- Foot on base plate protects workpiece and blades from scratches and damages.
- Rigid aluminum die-cast bracket.
- Both-side chip ejection
- Front base with 3 chamfering grooves

Specifications:- 

Planing width	82 mm (3-1/4")
Planing depth	3 mm (1/8")
No load speed (rpm)	12,000
Dimensions (L x W x H)	366x156x166 mm
Net weight	3.6 kg

Standard Equipment: Guide rule, Socket wrench

AVAILABLE VARIANTS		
5.0Ah	3.0Ah	"Z" VARIANT
DKP181 RTJ INCLUDES 2 BATTERIES / 1 CHARGER / MAKPAC CONNECTOR CASE	-	DKP181 Z TOOL ONLY (DOES NOT INCLUDE BATTERY / CHARGER OR CARRY CASE)

DKP180 82mm (3-1/4") Acc Pg. A182-184 **441** 

18V LXT - Lithium-ion Cordless Planer









Angle and shape of handle are easy to grip, push and carry.

- Precise planing depth setting by adjustment knob with click stops.
- Foot on base plate protects workpiece and blades from scratches and damages.
- Rigid aluminum die-cast bracket.

Specifications:- 

Planing width	82mm (3-1/4")
Planing depth	2.0mm (5/64")
No load speed (rpm)	14,000
Dimensions (L x W x H)	333x157x160mm
Net weight	3.4kg (7.4lbs)

Standard Equipment: Guide rule, Socket wrench

AVAILABLE VARIANTS		
5.0Ah	3.0Ah	"Z" VARIANT
-	-	DKP180 Z TOOL ONLY (DOES NOT INCLUDE BATTERY / CHARGER OR CARRY CASE)

DPJ180 Acc Pg. A185 **430** 

18V LXT - Lithium-ion Cordless Plate joiner









Provides up to 300 cuts or 150 joints on a single charge of BL1830.

- Rack-and-pinion vertical fence system engineered for accurate fence adjustments
- Cast aluminum pivot fence with three positive stops at 0°, 45° and 90°, and easy centering on 20mm material
- Six depth settings with one-touch stops for #0, #10, and #20 and most common biscuits sizes
- Can use the same accessories and attachments as AC model PJ7000

Specifications:- 

Planing width	100 mm (4")
Planing depth	20 mm (3/4")
No load speed (rpm)	6,500
Dimensions (L x W x H)	351x139x149 mm
Net weight	3.1 kg

Standard Equipment: Angle Guide, Lock Nut Wrench, Set Plate, Dust Bag

AVAILABLE VARIANTS		
5.0Ah	3.0Ah	"Z" VARIANT
-	-	DPJ180 Z TOOL ONLY (DOES NOT INCLUDE BATTERY / CHARGER OR CARRY CASE)

DCO181 Acc Pg. A186 **430** 

18V LXT - Lithium-ion Cordless Cut-Out Tool









Higher performance & easier operation than corded tools

- High power Cuts a layer of two drywalls. (t=12.5mm)
- High power delivered by BL motor
- Compact, lightweight and Less vibration
- Lightweight for reduced operator fatigue

Specifications:- 

Collet Capacity	3 mm, 6 mm or 3.18 mm(1/8"), 6.35 mm(1/4")
No Load Speed (RPM)	32,000
Circumference of Grip Portion	210 mm (8-1/4")
Vibration Level	Rotation w/o Load: 2.5 m/s ² or less
Sound Pressure Level	78 dB(A)
Dimensions (L x W x H)	311x79x117 mm
Net weight	1.7kg

Standard Equipment: Wrench

AVAILABLE VARIANTS		
5.0Ah	3.0Ah	"Z" VARIANT
DCO181 RTJ INCLUDES 2 BATTERIES / 1 CHARGER / MAKPAC CONNECTOR CASE	-	DCO181 Z TOOL ONLY (DOES NOT INCLUDE BATTERY / CHARGER OR CARRY CASE)

DCG180

18V LXT - Lithium-ion Cordless Caulking Gun



Excellent work efficiency.

- Variable speed control by dial and trigger switch for maximum control of sealant flow rate.
- 300ml and 600ml size holder can be used.
- Anti-drip function stops excess from oozing out just on release of the switch trigger.
- Rubberized soft grip provides comfortable grip and better control.

Specifications:-



Max pushing force	5,000N
No load speed	0-28mm/sec. (0-66in/min.)
Dimensions (L x W x H)	404x108x281mm
Net weight	2.1kg

Standard Equipment: Holder Set A, Safety Goggles

AVAILABLE VARIANTS		
5.0Ah	3.0Ah	"Z" VARIANT
-	-	DCG180 ZK TOOL WITH PLASTIC CARRY CASE (DOES NOT INCLUDE BATTERY / CHARGER)

Accessories

Standard Accessory

300ml size Holder Holder Set A (Part No. 196351-8)



Optional Accessory

600ml size Holder Holder Set B (Part No. 196352-6)



CORDLESS

FIXING / FASTENING

DRILLING / IMPACT DRILLING

CONCRETE DRILLING / DEMOLITION

CUTTING [CONCRETE/ MASONRY/ METAL]

MULTI TOOL

GRINDING

SANDING / POLISHING

SAWING

ROUTERING / PLANING

CLEANING

HEAT GUN / LASERS

PNEUMATIC TOOLS

GARDEN TOOLS

GENERATORS

DVP180

18V LXT - Lithium-ion Vacuum Pump



Cordless vacuum pump for air purge during installation of room air conditioner

- Removes all air from refrigerant tubing to create a vacuum environment before the tubing is charged with refrigerant gas.
- Long run time of 50 minutes with a fully charged BL1850B
- Compression type: Oil rotary type (vane type), Single stage
- Easy to carry with a compact and lightweight body

Specifications:-

Flow rate	50 L/min
Ultimate vacuum	20 Pa (150 microns)
Motor speed	3,840 min ⁻¹
Oil Tank Capacity	115 mL
Inlet port	5/16"
Dimensions (L x W x H)	265x93x175 mm (10-3/8"x3-5/8"x6-7/8")
Net weight	3.5 kg

Standard Equipment: Vacuum Pump Oil (Part no: A500VP050M), Adapter

AVAILABLE VARIANTS		
5.0Ah	3.0Ah	"Z" VARIANT
-	-	DVP180 Z TOOL ONLY (DOES NOT INCLUDE BATTERY / CHARGER OR CARRY CASE)

DVP180 - 18V LXT - Lithium-ion Vacuum Pump



Built-in metal mesh filter prevents vacuum pump oil from scattering from exhaust port Pump structure: single stage rotary type pump makes it feasible to achieve the final vacuum level



CORDLESS
FIXING / FASTENING
DRILLING / IMPACT DRILLING
CONCRETE DRILLING / DEMOLITION
CUTTING [CONCRETE/ MASONRY/ METAL]
MULTI TOOL
GRINDING
SANDING / POLISHING
SAWING
ROUTERING / PLANING
CLEANING
HEAT GUN / LASERS
PNEUMATIC TOOLS
GARDEN TOOLS
GENERATORS

DST112

18V LXT - Lithium-ion Cordless Stapler

Compact and Lightweight can Operable in either way of "contact actuation" or "single sequential actuation"

- Lightweight for reduced operator fatigue
- Built-in LED job light illuminates the work area
- Contact actuation mode drives staples repetitively for quick operation

Ergonomically designed grip



Staple window Plastic magazine

Continuous shooting



- Anti-dry-fire mechanism
- Low reaction force

Accessories

Staples (optional)

Length (mm)	Pcs/Pkg	Part No.
7 x 10	25,000	F-81518
10 x 10	15,000	F-81521

Driving depth adjustment (optional)

Driving depth is adjustable by installing this optional accessory

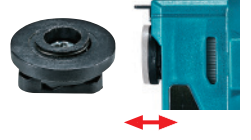

Part No. 197731-1

Specifications:-

Staple	Width: 10 mm (3/8") Length: 7 - 10 mm (9/32" - 3/8") Gauge: 0.5 x 0.7 mm
Magazine Capacity	150pcs (max 160) with BL1830B
Dimensions (L x W x H)	235x79x165 mm
Net weight	1.8 kg

Standard Equipment: Safety Goggles, Hook

AVAILABLE VARIANTS

5.0Ah	3.0Ah	"Z" VARIANT
	-	DST112 ZJ TOOL ONLY → MAKPAC CASE (DOES NOT INCLUDE BATTERY / CHARGER)

DST221

18V LXT - Lithium-ion Cordless Stapler



Machined aluminum magazine ensures smooth staple loading and feeding.

- Ergonomically designed rubberized grip provides more control and comfort.
- Driving depth adjustment is provided.
- Remaining staple view window.
- Staple can be fired one after the other.

Rubberized soft grip



Remaining staple view window

Machined aluminum magazine



4 stage depth control

Contact arm for bump fire

Accessories

Staples (optional)

Length (mm)	Pcs/Pkg	Part No.
10 x 10	5,040	F-32647
10 x 13	5,040	F-32650
10 x 16	5,040	F-32663
10 x 19	5,040	F-32676
10 x 22	5,040	F-32689

Specifications:-

Capacity	Width: 10mm (3/8") Length: 10, 13, 16, 19, 22mm (3/8, 1/2, 5/8, 3/4, 7/8")
Magazine capacity	98pcs : with BL1830B
Dimensions (L x W x H)	251x91x121mm
Net weight	2.4kg

Standard Equipment: Safety goggles

AVAILABLE VARIANTS

5.0Ah	3.0Ah	"Z" VARIANT
	-	DST221 Z TOOL ONLY (DOES NOT INCLUDE BATTERY / CHARGER OR CARRY CASE)

DPT353

18V LXT - Lithium-ion Cordless Pin Nailer



Low Reaction Force Mechanism Enables Easier Long Pin Nailing and High-Quality Finish

- Easy-to-see slim nose tip allows quick and easy access to a desired fastening point
- Nails can be fired in the groove of baseboard
- Shoots 6,400 nails on a single full BL1860B charge
- Contact arm mechanism enables "continuous nailing" and "drag nailing"

Specifications:-



Capacity	Length: 15, 18, 25, 30, 35 mm (5/8", 11/16", 1", 1-3/16", 1-3/8")
	Dia.: 0.6 mm (1/32")
	Gauge: 23 Ga
Magazine Capacity	120
Dimensions (L x W x H)	257x79x226 mm
Net weight	2.3 kg

Standard Equipment: Nose Adapter, Safety Goggles, Belt Clip, Hex Wrench

AVAILABLE VARIANTS

5.0Ah	3.0Ah	"Z" VARIANT
-	-	DPT353 Z TOOL ONLY (DOES NOT INCLUDE BATTERY / CHARGER OR CARRY CASE)

Accessories

Pin Nails (optional)

Length (mm)	Pcs/Pkg	Part No.
18mm	10,000	F-31825
25mm	10,000	F-31838
30mm	10,000	F-31841
35mm	10,000	F-31854

DPT351

18V LXT - Lithium-ion Cordless Pin Nailer



"Hose-less" enables to perform efficient operation in interior finish work without being disturbed by air hose.

- Uses pin nails from 18 to 35mm (11/16 to 1-3/8).
- Anti-dry-fire mechanism protects workpiece from damages.
- LED Job light for illuminated operation.
- Double trigger prevents accidental shooting.

Specifications:-



Capacity	Length : 18,25,30,35mm (11/16,1,1-3/16,1-3/8")
	Diameter : 0.6mm (1/32")
Magazine capacity	130pcs
Dimensions (L x W x H)	249x79x227mm (9-3/4"x3-1/8"x8-15/16")
Net weight	1.8kg (4.0lbs)

Standard Equipment: Safety goggles, Hex wrench

AVAILABLE VARIANTS

5.0Ah	3.0Ah	"Z" VARIANT
-	-	DPT351 Z TOOL ONLY (DOES NOT INCLUDE BATTERY / CHARGER OR CARRY CASE)

DFN350

18V LXT - Lithium-ion Cordless Brad Nailer



Ideal for light duty applications such as fastening chamfer strip to concrete form plywood wall

- Contact top designed for easy nail placement; Nail shooting port is located in the center of contact arm, enabling accurate nail placement
- Anti-slip contact top grips workpiece firmly regardless of the position of contact top, allowing for shooting nail into chamfer strip
- Slim nose adapter with a narrow tip width can be inserted into up to 6 mm wide groove of baseboard
- Contact arm mechanism enables "continuous nailing" and "drag nailing"

Nail outlet port placed in the center of the contact top

allows for easy aiming for precision nail placement.



Accessories

Brad Nails (optional)

Length (mm)	Pcs/Pkg	Part No.
15mm	5,000	B-04307
20mm	5,000	B-04313
25mm	5,000	B-04329

Spike grips workpiece firmly regardless of the position of the contact top.



Specifications:-



Capacity	Length: 15 - 35 mm / Gauge: 18 Ga
Magazine Capacity	110
Shot q'ty on a single full battery charge	w/ BL1850B: 4,000
Vibration Level	2.5 m/s ² or less
Sound Pressure Level	81 dB(A)
Sound Power Level	92 dB(A)
Dimensions (L x W x H)	257x79x228 mm
Net weight	2.4 kg

Standard Equipment: Safety Goggles, Belt Clip, Hex Wrench

AVAILABLE VARIANTS

5.0Ah	3.0Ah	"Z" VARIANT
DFN350 RTJ INCLUDES 2 BATTERIES / 1 CHARGER / MAKPAC CONNECTOR CASE	-	DFN350 Z TOOL ONLY (DOES NOT INCLUDE BATTERY / CHARGER OR CARRY CASE)

Length (mm)	Pcs/Pkg	Part No.
30mm	5,000	B-04335
35mm	5,000	B-04357

CORDLESS

FIXING / FASTENING

DRILLING / IMPACT DRILLING

CONCRETE DRILLING / DEMOLITION

CUTTING [CONCRETE/ MASONRY/ METAL]

MULTI TOOL

GRINDING

SANDING / POLISHING

SAWING

ROUTERING / PLANING

CLEANING

HEAT GUN / LASERS

PNEUMATIC TOOLS

GARDEN TOOLS

GENERATORS



Keep Clean / Stay Healthy With Makita Li-ion Cordless Cleaners

BL MOTOR
HIGH PERFORMANCE
with Brushless Motor
(for selected tools only)

LOW VIBRATION / LOW NOISE / ZERO EMISSION

LITHIUM-ION Charger
- Optimizes the Battery
- Runs Cooler
- Fast Charging Time

LITHIUM-ION Battery
Constant power and run time protects the machines against overload, over-discharge, and overheating

FOR RESIDENTIAL / COMMERCIAL USE

FREEDOM OF MOVEMENT / LIGHT WEIGHT / COMPACT / POWERFUL

18v+18v Li-ion Upright Vacuum Cleaner
DVC560

18v+18v Li-ion Backpack Vacuum Cleaner
DVC261 / DVC660 / DVC665

18v+18v Li-ion Vacuum Cleaner
DVC150L / DVC180L / DVC154L / DVC184L

Li-ion Stick Cleaners
DCL281 / DCL180 (18V) / CL108FD / 6FD (12V max)

18v Li-ion Cyclone Cleaner
DCL501

Li-ion Car Cleaner
DCL184 (18V) / CL121D (12V max)

18v Li-ion Robotic Cleaner
DRC200

18v Li-ion Portable Cleaner
DVC750L

Wide range of attachments available for all types of cleaning needs



DRC200

18V LXT - Lithium-ion Cordless Robotic Cleaner



Robotic cleaner for commercial/industrial use

- Able to clean an area of 300m² per 120min, with a coverage rate of 80% (two BL1830B in parallel)
- Wireless remote controller

Automatic cleaning (Selectable two dust collection modes)

Pattern cleaning mode

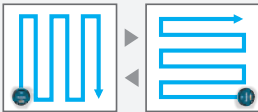

Random cleaning mode

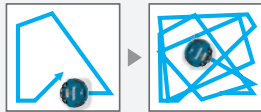

Cleaning area setting function

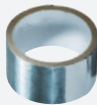
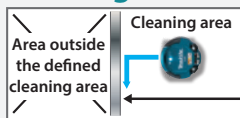

Boundary line tape
Part no: SH00000231

Enables user to define a cleaning area by putting boundary tape on the floor as boundary line that the cleaner cannot pass

Large side brushes + Large power brush

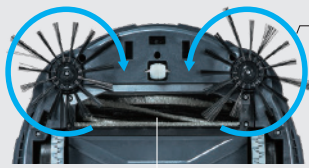

Side brushes enable to clean alongside walls, around obstacles or tight corners in either of pattern/random



ø50mm x 260mm Large Power rotating brush

Power Brush Part no: SH00000063
Turn Brush Cover Part no: SH00000064

Side Brush Part no: SH00000065

Dust box with 2.5L capacity

Dual compartment structure - one for small debris, the other for large debris and Equipped with a highly efficient **filter Part no: SH00000213**



Excellent cleaning features useful in commercial applications



Factory

Office

Warehouse

Store

Specifications:-

Continuous use (minutes)	120-200
Max cleaning area	with BL1830Bx2: 300 m ² with BL1850Bx2: 500 m ²
Max running speed	0.3 m/sec
Tank	2.5L
Dimensions (L x W x H)	460x460x180mm
Net weight	7.3kg

Standard Equipment: Wireless remote controller (including two AAA alkaline batteries), Side brush, Boundary tape (15m roll)

AVAILABLE VARIANTS

5.0Ah	3.0Ah	"Z" VARIANT
-	-	DRC200 Z TOOL ONLY (DOES NOT INCLUDE BATTERY / CHARGER OR CARRY CASE)



RoboPRO

Makita's Intelligent Robotic Cleaner

Excellent cleaning features useful in commercial applications

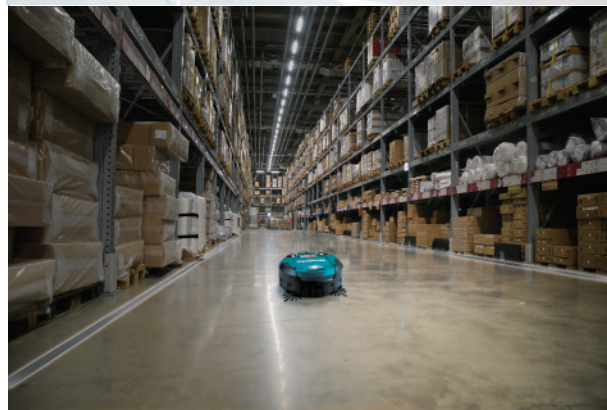

CORDLESS

FIXING / FASTENING

DRILLING / IMPACT DRILLING

CONCRETE DRILLING / DEMOLITION

CUTTING [CONCRETE / MASONRY / METAL]

MULTI TOOL

GRINDING

SANDING / POLISHING

SAWING

ROUTERING / PLANING

CLEANING

HEAT GUN / LASERS

PNEUMATIC TOOLS

GARDEN TOOLS

GENERATORS

CORDLESS
FIXING / FASTENING
DRILLING / IMPACT DRILLING
CONCRETE DRILLING / DEMOLITION
CUTTING (CONCRETE/ MASONRY/ METAL)
MULTI TOOL
GRINDING
SANDING / POLISHING
SAWING
ROUTERING / PLANING
CLEANING
HEAT GUN / LASERS
PNEUMATIC TOOLS
GARDEN TOOLS
GENERATORS

DVC750L Tool Attachments Pg. T247-254 | Acc Pg. A189-193

18V LXT - Lithium-ion Cordless Vacuum Cleaner / Dust Extractor / Blower



18V LITHIUM-ION
BL MOTOR
HEPA filter

Compact, portable and easy-to-use
 3 in ONE tools (Cleaning / Dust Extraction / Blowing)
 High power and long run time with Brushless Motor

Nozzle can be stored



Blower outlet Insert the hose to blower outlet and turn it clockwise until it clicks.

Hose can be stored



For vacuum cleaning
Elastic Hose: 28mm -2m with from cuff 38



Concrete Drilling
(with Combination Hammer)



Concrete Cutting
(with Angle Grinder)



Wood Cutting
(with Jig Saw)



Wood Cutting
(with Circular Saw)

Specifications:-

Capacity	Dust : 7.5 L / Water 4.5 L
Continuous Use (min.)	w/ BL1860B (High) : 35 / w/ BL1860B (Low) : 70
Max Air Flow	1.6 m³/min
Max Sealed Suction	6.7 kPa
Suction Power	High / Low : 50 / 25 W
Dimensions (L x W x H)	418x251x278 mm
Net weight	4.6 kg

Standard Equipment: Hose, Floor Nozzle, Sash Nozzle

AVAILABLE VARIANTS

5.0Ah	3.0Ah	"Z" VARIANT
-	-	DVC750L ZX1 TOOL ONLY (DOES NOT INCLUDE BATTERY / CHARGER OR CARRY CASE)

DVC350 Tool Attachments Pg. T247-254 | Acc Pg. A194

18V LXT - Lithium-ion Cordless Dust Extractor / Blower



18V LITHIUM-ION

Portable Dust extractor powered by 18V Li-ion battery.

- Variable switch provides High/Low air volume settings to suit your application.
- Shoulder belt can be easily slung over your shoulder for added mobility.

2 functions in 1 machine
Convertible into a blower by attaching nozzle assembly.



Nozzle assembly

Length	Part No.
220mm	132025-7
430mm	134182-7

Anchor nozzle Part no: 192236-6
used with nozzle assembly for blower option



Convenient for use with Makita cordless tools



Concrete Drilling
(with Combination Hammer)



Concrete Cutting
(with Angle Grinder)



Wood Cutting
(with Jig Saw)



Wood Cutting
(with Circular Saw)

Specifications:-

Max. peak air flow	3.4m³ / min
Max. sealed suction (water column)	5.5kpa
Recoverable capacity	3.0L
Dimensions (L x W x H)	273 x 195 x 226mm
Net weight	2.2kg

Standard Equipment: Nozzle Assembly, Dust Bag Assembly, Hose Complete with front cuffs, Shoulder Belt

AVAILABLE VARIANTS

5.0Ah	3.0Ah	"Z" VARIANT
-	-	DVC350 Z TOOL ONLY (DOES NOT INCLUDE BATTERY / CHARGER OR CARRY CASE)

DCL184

Acc Pg. A189-191

18V Li-ion LXT Lithium-ion Cordless Cleaner / Blower



Compact cordless cleaner Powered by 18V Li-ion LXT battery

- Ideal for in-car cleaning
- Variable attachments suitable for in-car cleaning
- 2 functions in 1 machine convertible into a blower
- Up to 33 / 50 / 133min. of continuous use from a single fully charged BL1850B
- Battery capacity warning lamp starts blinking when the remaining battery capacity gets low

Ideal for in-car cleaning



Especially designed variable attachments



Rubber nozzle 330
422437-5



Seat nozzle 120 complete
140H95-0



Mat nozzle 120
459056-4



Soft brush 360 complete
140H94-2



Blower nozzle complete
140J64-3

Tool Bag (only with DCL184RF)



Paper filter set (5pcs/set)
(Optional)
Part No. 194566-1



Specifications:-



Capacity	Cloth / Paper Dust Bag: 500 / 330 mL
Continuous Use(min.)	Max / High / Normal: 33 / 50 / 133
Max Air Flow/	Cleaning: 1.4 m³/min / Blowing: 0.8 m³/min
Max Air Velocity	Blowing: 7.2 m/s
Max Sealed Suction (water column)	5.4 kPa
Dimensions (L x W x H)	365x138x202 mm
Net weight	2.2 kg

Standard Equipment: Seat Nozzle, Mat Nozzle, Rubber Nozzle, Soft Brush, Blower Attachment, Dust Bag, Paper Dust Bag, Shoulder Belt

AVAILABLE VARIANTS

5.0Ah	3.0Ah	"Z" VARIANT
	DCL184 RF 1 PC BATTERY AND CHARGER WITH TOOL BAG	DCL184 Z TOOL ONLY (DOES NOT INCLUDE BATTERY / CHARGER ANDS TOOL BAG)

DCL501

Acc Pg. A189-192

18V LXT - Lithium-ion Cordless Cyclone Cleaner

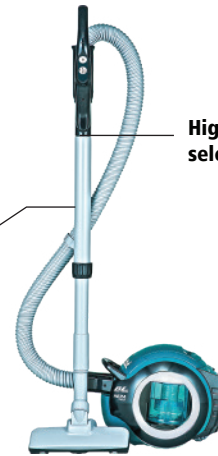

High / Low Power selection

Telescopic pipe

Can be extended to allow for grip height adjustment to suit users height.

Warning lights



1. Orange LED indicator for filter cleaning warning
2. Red LED indicator for battery capacity warning

HEPA filter with high filtration capacity

Advanced Filtration system with cyclone separation

Cleaner has the advanced Cyclonic filtration system with HEPA filter collects large and small dust particles efficiently



Easy dust disposal



- Dust cup can be removed for easy dust disposal simply by pulling up the cup release lever then by pushing the release button
- The dust cup and the filter are washable in water



Specifications:-



Capacity	250 mL
Continuous Use (min.)	High: 35 / Low: 77 (with BL1860B)
Max Air Flow	1.2 m³/min
Max Sealed Suction	10 kPa
Dimensions (L x W x H)	352x189x252 mm
Net weight	3.1 kg

Standard Equipment: Shoulder Belt, Crevice Nozzle, Cleaning Brush, Floor Nozzle, Telescopic Pipe, Hose, Hose Hook

AVAILABLE VARIANTS

5.0Ah	3.0Ah	"Z" VARIANT
		DCL501 Z TOOL ONLY (DOES NOT INCLUDE BATTERY / CHARGER OR CARRY CASE)

CORDLESS

FIXING / FASTENING

DRILLING / IMPACT DRILLING

CONCRETE DRILLING / DEMOLITION

CUTTING [CONCRETE/ MASONRY/ METAL]

MULTI TOOL

GRINDING

SANDING / POLISHING

SAWING

ROUTERING / PLANING

CLEANING

HEAT GUN / LASERS

PNEUMATIC TOOLS

GARDEN TOOLS

GENERATORS

CORDLESS
FIXING / FASTENING
DRILLING / IMPACT DRILLING
CONCRETE DRILLING / DEMOLITION
CUTTING (CONCRETE/ MASONRY/ METAL)
MULTI TOOL
GRINDING
SANDING / POLISHING
SAWING
ROUTERING / PLANING
CLEANING
HEAT GUN / LASERS
PNEUMATIC TOOLS
GARDEN TOOLS
GENERATORS

DCL281
Acc Pg. A188-194

18V LXT - Lithium-ion Cordless Cleaner



Quiet cleaning & Low vibration
Ideal for Commercial and Home Use

Achieved by noise absorbing sponge attached inside housing.
 Low vibration achieved by using softer elastomer on fan cover.

- Brushless Motor Provides: High Power | High Performance | High Durability
- Connect various types of nozzles to clean commercial spaces like shops, offices, hospitals, aircrafts, trains, home use, etc.
- Free From cord: 18V Li-ion Battery: World's largest compatible lithium-ion system

Push button with 3-speed power selection (high/medium/low) for efficient operation



LED joblight



Durability



Pipe is fixed with the locking mechanism to prevent it from accidentally coming off.

750mL Capsule Type Dust Box



Easy to empty the dust out by single turn of the dust box

Straight Pipe with beveled end
 Cleaning of tight places can be done without nozzle

Hepa filter is used with either Pre-filter or Easy shake off filter

+

or

HEPA Filter
 High Durability Filter System Designed for capturing extra fine dust

HEPA Filter
 Part No.199989-8 (Standard equipment)

Pre-filter:
 Part No. 198750-0 (Standard equipment)

Easy shake off filter:
 Part No.199966-0 (Optional)

Specifications:-

Capacity	750 mL
Continuous Use (min.)	Max: 15 High: 20 Low: 50 (with BL1830B)
	Max: 25 High: 33 Normal: 83 (with BL1850B)
	Max: 30 High: 40 Normal: 100 (with BL1860B)
Max Air Flow	1.5 m³/min
Max Sealed Suction	8.2 kPa (820 mm H2O)
Suction Power	Max / High / Low : 60 / 45 / 15 W
Dimensions (L x W x H)	1,016x113x154 mm
Net weight	1.6 kg

Standard Equipment: Floor Nozzle, Sash Nozzle, Sash Nozzle Holder, Straight Pipe, Prefilter, HEPA Filter

AVAILABLE VARIANTS

5.0Ah	3.0Ah	"Z" VARIANT
-	-	DCL281 Z TOOL ONLY

DCL180
Acc Pg. A188-194

18V LXT - Lithium-ion Cordless Cleaner



Optimum cordless cleaner for constructors or industrial users
Dust disposal can be cleaner and simpler with disposable paper dust bag.

- Touch button switch with High/Low suction power settings.
- LED battery power warning lamp.
- Improved front cover design for easy dust bag removal.

Ergonomic handle with easy on/off trigger switch

Rubberized soft grip

650 mL Large dust capacity

Sash Nozzle



Capsule Type
 Quick dust disposal
 No need to use paper bag



Floor T-nozzle with enhanced maneuverability



Angled suction port
 Prevents extension pipe from wobbling in use



Specifications:-

Capacity	650 mL
Continuous Use (min.)	20 min (with BL1830B)
Max Air Flow	1.4 m³/min
Max Sealed Suction	4.2 kPa
Dimensions (L x W x H)	999x114x152 mm
Net weight	1.2 kg

Standard Equipment: Floor T-Nozzle28, Sash Nozzle, Sash Nozzle Holder, Pipe, Filter, Prefilter

AVAILABLE VARIANTS

5.0Ah	3.0Ah	"Z" VARIANT
-	DCL180 RF INCLUDES 1 BATTERY / 1 CHARGER	DCL180 Z TOOL ONLY

Cyclone attachment

Cyclonic Vacuum Attachment is designed to expand the capacity to collect debris.

- Powerful cyclonic action captures up to 90% of dust particles before entering the main dust box
- Reduces the frequency of emptying the main dust box
- One-touch release for easy disposal of debris



With lock system
Part # 191D71-3
(for stick type cleaners & Backpack cleaners with lock system)

Without lock system
Part # 199491-1
(for stick type cleaners & Backpack cleaners without lock system)



Wall Bracket

Part # 199971-7

Easy Storage with Vacuum Wall Mount Bracket
Get the convenient storage

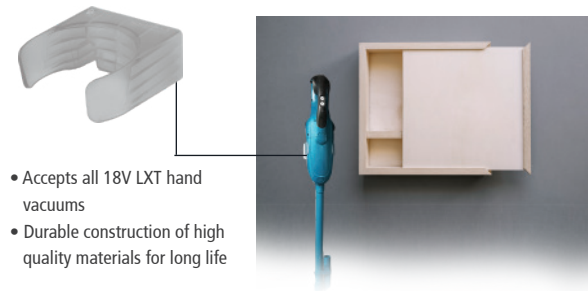

- Accepts all 18V LXT hand vacuums
- Durable construction of high quality materials for long life

BAP18C - 18V LXT Battery Adapter for Stick Cleaner

Part # 191M50-5

Specially designed for use with 18V LXT cordless cleaners
Transfers the battery weight from the cleaner to user's waist to reduce the stress on hand



DLX2248PT1

LXT - Lithium-ion Cordless Cleaner Combo Kit



DVC260Z
18+18v Li-ion Backpack
Vacuum Cleaner



36V BL MOTOR

DCL181FZ
18V Li-ion Cleaner



18V LITHIUM-ION

2 Port Charger
DC18RD



3Pcs x 18V Li-ion
5.0Ah Battery
BL1850B



Flexible
Hose



Rubber
Nozzle



Round
Brush



Corner
Nozzle



Seat
nozzle



10pcs Cloth Filter
for DVC260



10pcs Paper Filter
for DCL181



Specifications:-	DCL181	DVC260
Capacity	650 mL	2.0L
Continuous Use (min.)	High: 20 / Low: 40 (with BL1830B)	High: 60 / Low: 90 (with BL1850Bx2)
Max Air Flow	1.4 m³/min	1.5m³ / min
Max Sealed Suction	5.3 kPa	7.1kPa
Dimensions (L x W x H)	999x114x152 mm	230x152x373mm
Net weight	1.2 kg	4.3kg

CORDLESS

FIXING /
FASTENING

DRILLING /
IMPACT DRILLING

CONCRETE DRILLING /
DEMOLITION

CUTTING
[CONCRETE/ MASONRY/
METAL]

MULTI TOOL

GRINDING

SANDING /
POLISHING

SAWING

ROUTERING /
PLANING

CLEANING

HEAT GUN / LASERS

PNEUMATIC TOOLS

GARDEN TOOLS

GENERATORS

- CORDLESS
- FIXING / FASTENING
- DRILLING / IMPACT DRILLING
- CONCRETE DRILLING / DEMOLITION
- CUTTING [CONCRETE/ MASONRY/ METAL]
- MULTI TOOL
- GRINDING
- SANDING / POLISHING
- SAWING
- ROUTERING / PLANING
- CLEANING
- HEAT GUN / LASERS
- PNEUMATIC TOOLS
- GARDEN TOOLS
- GENERATORS

DUC254 - 250 mm (10")

Acc Pg. A207-208

18V LXT - Lithium-ion Cordless Chain saw



BL MOTOR

High operating efficiency
Outer Rotor BL Motor provides high operating efficiency

High operability
Chain brake and Variable speed trigger switch provide high operability equivalent to engine chain saw.

Specifications:-

Guide Bar Length	250 mm (10")
Chain Pitch / Chain Gauge	3/8" / 1.1 mm (0.043") 3/8" / 1.3 mm (0.050")
Chain Speed	0 - 24 m/s (0 - 1,440 m/min) (0 - 4,720 FPM)
Chain Oil Tank Volume	140 mL
Sound Pressure Level	92.2 dB(A)
Sound Power Level	103.2 dB(A)
Vibration Level	Cutting Wood: 3.1 m/s ²
Dimensions (L x W x H)	w/o Guide Bar : 258x184x191 mm
Net weight	3.2 kg

Standard Equipment: Saw Chain, Guide Bar, Guide Bar Cover, Wrench, Accessory Bag

AVAILABLE VARIANTS		
5.0Ah	3.0Ah	"Z" VARIANT
-	-	DUC254 Z TOOL ONLY (DOES NOT INCLUDE BATTERY / CHARGER OR CARRY CASE)



Captive nut
prevent loss of nut when removing sprocket cover to replace guide bar or saw chain.

Max. chain speed
24 m/s
Saw chain: 90px or 91px

Work amount*
190 cut
BL1860B

*Work amount (approx): cuts (Cut 50mm x 50mm cedar timber with 91PX saw chain under the normal condition.)

DUN500W - 500 mm

Acc Pg. A209

18V LXT - Lithium-ion Cordless Pole Hedge Trimmer (Curved blades)

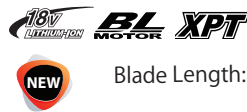

Blade Length: 500 mm (19-3/4")

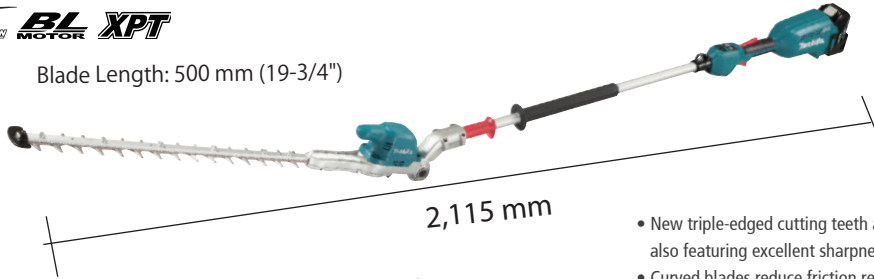

Variable 3-speed

High : 0-4,400 SPM
Medium : 0-3,600 SPM
Low : 0-2,000 SPM

115° foldable for easy transport and storage: Built-in clutch works to stop the blade motion even if the throttle lever is touched while 115° folding.

Run time*
High / Med / Low
60 / 90 / 190 min
Battery: BL1860B

*No load continuous run time (approx) : min

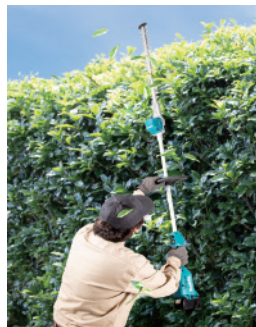
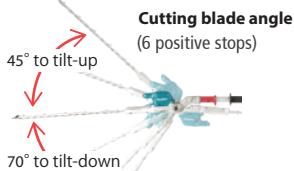

- New triple-edged cutting teeth are designed to easily catch and firmly hold twigs, also featuring excellent sharpness
- Curved blades reduce friction resistance to suppress energy loss.
- Reverse rotation system frees the blade when it is jammed by thick branches

Specifications:-

Blade Length	500 mm (19-3/4")
Max Cutting Capacity	23.5 mm (15/16")
Sound Pressure Level	81.5 dB(A)
Sound Power Level	92.5 dB (A)
Vibration Level: Left hand (Front grip / Handle)	4.7 m/s ²
Vibration Level: Right hand (Rear grip)	2.5 m/s ² or less
Strokes Per Minute (SPM)	High / Med / Low: 4,400 / 3,600 / 2,000
Overall length	2,115 mm
Net weight	4.5 kg

Standard Equipment: Blade Cover, Harness

AVAILABLE VARIANTS		
6.0Ah	3.0Ah	"Z" VARIANT
DUN500W RGE 2PCS OF BATTERIES / 1PC CHARGER (DOES NOT INCLUDE CARRY CASE)	-	DUN500W Z TOOL ONLY (DOES NOT INCLUDE BATTERY / CHARGER OR CARRY CASE)

18V LXT - Lithium-ion Cordless Hedge Trimmer

Same cutting performance as Engine models



High operating efficiency

Outer Rotor BL Motor provides high operating efficiency

Optimum blade shape for smooth cutting



Sharp edge blades :
Upper blade...curving downward
Lower blade...curving upward

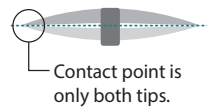

Twigs are caught easily and held firmly

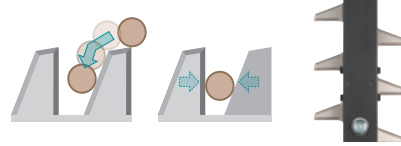

Reverse rotation system

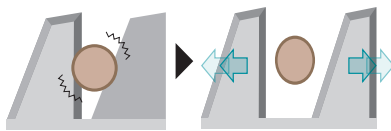
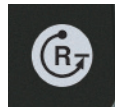

Anti-vibration structure

consisting of Motor-crank section and handle section linked by 5 cushions to absorb vibration from blade and motor-crank section

Anti-vibration structure



Predecessor model

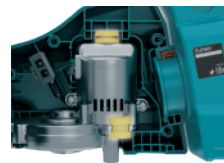
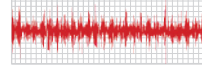

5 position rotating rear handle

- Locks at 45° and 90° left and right and 0°.
- Makes vertical and angled trimming easier and faster.



(Only with DUH751)

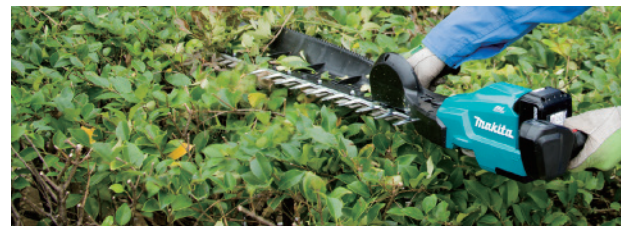
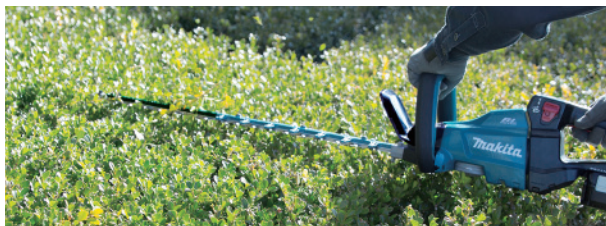

DUH751 - 750 mm

Acc Pg. A209

18V LXT - Lithium-ion Cordless Hedge Trimmer



double side blade



18V LXT BL Cordless Hedge Trimmer with double side blade

- Reliable cutting performance like engine/AC hedge trimmers
- The no load continuous run time on a full battery charge is the same or longer than that on a full tank of petrol

Specifications:-



Blade Length	750 mm
Max Cutting Capacity	23.5 mm
Sound Pressure Level	84 dB(A)
Sound power level	97 dB(A)
Vibration Level	2.5 m/s ²
Strokes Per Minute (SPM)	High / Med / Low: 0 - 4,400 / 0 - 3,600 / 0 - 2,000
Dimensions (L x W x H)	1,261x225x192 mm
Net weight	4.5 kg

Standard Equipment: Blade Cover, Safety Goggles

AVAILABLE VARIANTS

5.0Ah	3.0Ah	"Z" VARIANT
DUH751 PTE 2PCS OF BATTERIES / 1PC TWO PORT CHARGER (DOES NOT INCLUDE CARRY CASE)	-	DUH751 Z TOOL ONLY (DOES NOT INCLUDE BATTERY / CHARGER OR CARRY CASE)

DUH754S - 750 mm

Acc Pg. A209-210

18V LXT - Lithium-ion Cordless Hedge Trimmer



single side blade



18V LXT BL Cordless Hedge Trimmer with single side blade

- Reliable cutting performance like engine/AC hedge trimmers
- The no load continuous run time on a full battery charge is the same or longer than that on a full tank of petrol

Specifications:-



Blade Length	750 mm
Max Cutting Capacity	23.5 mm
Sound Pressure Level	80.6 dB(A)
Sound power level	91.6 dB (A)
Vibration Level	2.5 m/s ² or less
Strokes Per Minute (SPM)	High / Med / Low: 0 - 4,400 / 0 - 3,600 / 0 - 2,000
Dimensions (L x W x H)	1,198x280x147 mm
Net weight	4.1 kg

Standard Equipment: Blade Cover, Safety Goggles

AVAILABLE VARIANTS

5.0Ah	3.0Ah	"Z" VARIANT
-	-	DUH754S Z TOOL ONLY (DOES NOT INCLUDE BATTERY / CHARGER OR CARRY CASE)

CORDLESS

FIXING / FASTENING

DRILLING / IMPACT DRILLING

CONCRETE DRILLING / DEMOLITION

CUTTING [CONCRETE / MASONRY / METAL]

MULTI TOOL

GRINDING

SANDING / POLISHING

SAWING

ROUTERING / PLANING

CLEANING

HEAT GUN / LASERS

PNEUMATIC TOOLS

GARDEN TOOLS

GENERATORS

CORDLESS
FIXING / FASTENING
DRILLING / IMPACT DRILLING
CONCRETE DRILLING / DEMOLITION
CUTTING [CONCRETE/ MASONRY/ METAL]
MULTI TOOL
GRINDING
SANDING / POLISHING
SAWING
ROUTERING / PLANING
CLEANING
HEAT GUN / LASERS
PNEUMATIC TOOLS
GARDEN TOOLS
GENERATORS

DUR190 Acc Pg. A210-212

18V LXT - Lithium-ion Cordless Grass Trimmer

18V LXT BL ADT Cordless Grass Trimmer, Lightweight design with excellent tool balance for easy handling during operation

ADAPT TO METAL BLADE
NYLON CUTTING HEAD
PLASTIC BLADE

Offset bike handle
Soft grip of ergonomic design

Toolless shaft lock for easy blade change
The shaft can be locked also with the supplied hex wrench 4 as previously

The vertical center line of the handle bar always stays aligned with that of user

- enabling user to work with less fatigue even in long continuous operation.
- allowing for a wider swing.

One protector for metal blade / plastic blade / trimmer head

Brushless DC motor Max. 6,000min⁻¹

Anti-weed winding guard
The guard integed with receive washer prevents weed winding.

ADT Automatic torque Drive Technology

RPM is automatically shifted to 3,500 - 6,000 min⁻¹ according to density of weeds.

In areas of thin weed
This enables energy saving and low noise operation.

In areas of thick weed
... and high power

Also the speed can be changed between 4,000/5,000/6,000 manually by pressing the button.

Grass clippings can be removed if grass clippings stuck

Equipped with reverse switch for easy removal of grass clippings stuck on the blade; grass clippings can be removed from and around the blade by slow reverse rotation of the blade.

Specifications:-

Cutting Width	Trimmer Head: 300 mm Metal Blade: 230 mm Plastic Blade: 255 mm
Max Run Time (min)	66 / 89 / 210 (with nylon cutting head) (BL1860B)
No Load Speed (RPM)	3,500 - 6,000
Spindle Size	M10 x 1.25 LH
Dimensions (L x W x H)	1,836x610x473 mm
Net weight	3.4 kg

Standard Equipment: Safety Goggles, Hex Wrench

AVAILABLE VARIANTS		
5.0Ah	3.0Ah	"Z" VARIANT
DUR190 RT INCLUDES 2 BATTERIES / 1 CHARGER		DUR190 Z TOOL ONLY (DOES NOT INCLUDE BATTERY / CHARGER)

DUR189 Acc Pg. A210-212

18V LXT - Lithium-ion Cordless Grass Trimmer

18V LXT BL ADT Cordless Grass Trimmer, Short Telescopic Pipe, Loop Handle (3 Speed Control)

- Comfortable short telescopic pipe provides easy handling in tight spaces
- Multifunctional control panel for power on-off / variable speed control / reversing blade rotation
- Nylon cutting head rotating clockwise prevents grass clippings from flying towards user's side

Specifications:-

Cutting Width	Trimmer Head: 300 mm
No Load Speed (RPM)	High / Medium / Low / ADT Mode: 6,000 / 5,000 / 4,000 / 4,000 - 6,000
Spindle Size	M8 x 1.25 RH
Vibration Level	Front / Rear: 2.1 / 1.6 or less
Dimensions (L x W x H)	1,518-1,618x258x369 mm
Max Run Time (min)	with BL1850B: 139
Net weight	3.1 - 3.4 kg (6.8 - 7.5 lbs.)

Standard Equipment: Safety Goggles, Hex Wrench

AVAILABLE VARIANTS		
5.0Ah		"Z" VARIANT
	DUR189 RFE INCLUDES 2 BATTERIES / 1 CHARGER	DUR189 Z TOOL ONLY (DOES NOT INCLUDE BATTERY / CHARGER)

DUM604 Acc Pg. A209-210

18V LXT - Lithium-ion Cordless Grass Shear

18V LXT Li-Ion Cordless 16 cm Grass Shear

- Ergonomically designed handle with sure grip provides more control and comfort
- Grass receiver for reduced grass clean-ups
- Up to 250 min of run time on a single battery BL1860B charge
- 2,500 SPM for efficient cutting
- 2 in 1: Both trimmer blade and shear blade can be attached

Specifications:-

Cutting Width	160 mm
Depth Adjustment	15, 20, 25 mm
Strokes Per Minute (SPM)	2,500
Continuous Use (min.)	with BL1860B / BL1850B/ BL1830B: 250 / 200 / 125min
Sound Pressure Level	76 dB(A)
Vibration Level	2.5 m/s ² or less
Dimensions (L x W x H)	337x177x131 mm
Net weight	1.8 kg

Standard Equipment: Grass shear blade, Grass Receiver, Blade Cover, Hedge Trimmer Blade (only with "z" variant)

AVAILABLE VARIANTS		
5.0Ah	3.0Ah	"Z" VARIANT
DUM604 RT INCLUDES 1 BATTERY / 1 CHARGER + GRASS SHEAR BLADE		DUM604 ZX TOOL + GRASS SHEAR BLADE + HEDGE TRIMMER BLADE ONLY (DOES NOT INCLUDE BATTERY / CHARGER)

DUB185 Acc Pg. A213

18V LXT - Lithium-ion Cordless Blower



18V LXT Li-Ion Cordless blower with 3 variable speed and increased air volume for higher blowing efficiency

- Larger air volume has been obtained by increasing the air outlet diameter
- Compact and ergonomic design
- Lightweight for reduced operator fatigue
- Rubberized soft grip handle for increased operator comfort
- Vacuum option can enable with optional accessories

Specifications:-



Blowing force	3.1N (with nozzle)
Max Air volume	3.2m³/min (without nozzle)
Max air velocity	98m/s (with nozzle)
Air pressure	5.8kPa
Air outlet diameter	ø40mm
No load speed (rpm)	0-18,000
Continuous run time	5.0Ah: Hi:21 / Mi:50 / Lo: 130mins / 3.0Ah: Hi:13 / Mi:30 / Lo: 80mins
Noise level	83dB(A)
Dimensions (L x W x H)	517x156x210mm
Net weight	2.1kg

Standard Equipment: Nozzle

AVAILABLE VARIANTS		
5.0Ah	3.0Ah	"Z" VARIANT
	DUB185 RF INCLUDES 1 BATTERY / 1 CHARGER	DUB185 Z TOOL ONLY (DOES NOT INCLUDE BATTERY / CHARGER)

DUB184 Acc Pg. A213

18V LXT - Lithium-ion Cordless Blower

18V LXT Li-Ion Powerful Cordless blower with BL motor

- Ideal for clearing fallen leaves on pavement, grass and hedge clippings or other light debris
- Efficient clearing with high-efficiency axial fan similar to LXT model DUB362
- Variable speed control by trigger, with Cruise control lever for lock-on operation

Specifications:-

Blowing force	10.9N (with nozzle)
Max Air volume	13.0 m³/min (with nozzle)
Max air velocity	52.1 m/s (with nozzle)
Air pressure	5.8kPa
Air outlet diameter	ø40mm
No load speed (rpm)	0-18,000
Continuous run time	6.0Ah: 12mins / 5.0Ah: 10mins
Sound pressure level	86.6 dB(A)
Sound power level	93.5 dB(A)
Dimensions (L x W x H)	825x160x285 mm
Net weight	3kg

Standard Equipment: Nozzle, Hex Wrench

AVAILABLE VARIANTS		
5.0Ah	3.0Ah	"Z" VARIANT
DUB184 RT INCLUDES 1 BATTERY / 1 CHARGER	-	DUB184 Z TOOL ONLY (DOES NOT INCLUDE BATTERY / CHARGER)

DUB182 Acc Pg. A213

18V LXT - Lithium-ion Cordless Blower



18V LXT Li-Ion Cordless Blower with 3 variable speed

- Compact and ergonomic design
- Lightweight for reduced operator fatigue
- Rubberized soft grip handle for increased operator comfort
- Vacuum option can enable with optional accessories

Specifications:-

Blowing force	2.4N (with nozzle)
Max Air volume	2.6m³/min (without nozzle)
Max air velocity	89m/s (with nozzle)
Air pressure	5.4kPa
Air outlet diameter	ø36mm
No load speed (rpm)	0-18,000
Continuous run time	5.0Ah: Hi:20 / Mi:42 / Lo: 125mins / 3.0Ah: Hi:12 / Mi:25 / Lo: 75mins
Noise level	87dB(A)
Dimensions (L x W x H)	525x155x212mm
Net weight	2.1kg

Standard Equipment: Nozzle

AVAILABLE VARIANTS		
5.0Ah	3.0Ah	"Z" VARIANT
		DUB182 Z TOOL ONLY (DOES NOT INCLUDE BATTERY / CHARGER)

DVF104 10L Acc Pg. A214

18V LXT - Lithium-ion Cordless Garden Sprayer



18V LXT Li-Ion Cordless 10 L Garden Sprayer

- Environment-friendly with no emission and extremely low noise
- Hand valve lever with two selectable modes
- Reduced running cost with rechargeable Li-ion battery
- Compact and lightweight cordless sprayer provides easy handling and high maneuverability
- Two different nozzles included as standard equipment for added versatility

Specifications:-

Max Pressure	0.3 MPa
Chemical tank	10 L
Dimensions (L x W x H)	315x225x415 mm
Net weight	4.1 kg

Standard Equipment: Upright Double-Headed Nozzle, Wide-Angle Herbicide Nozzle, Spray Pipe Holder, Shoulder Harness

AVAILABLE VARIANTS		
5.0Ah	3.0Ah	"Z" VARIANT
		DVF104 Z TOOL ONLY (DOES NOT INCLUDE BATTERY / CHARGER)

CORDLESS
FIXING / FASTENING
DRILLING / IMPACT DRILLING
CONCRETE DRILLING / DEMOLITION
CUTTING [CONCRETE/ MASONRY/ METAL]
MULTI TOOL
GRINDING
SANDING / POLISHING
SAWING
ROUTERING / PLANING
CLEANING
HEAT GUN / LASERS
PNEUMATIC TOOLS
GARDEN TOOLS
GENERATORS

- CORDLESS
- FIXING / FASTENING
- DRILLING / IMPACT DRILLING
- CONCRETE DRILLING / DEMOLITION
- CUTTING (CONCRETE/ MASONRY/ METAL)
- MULTI TOOL
- GRINDING
- SANDING / POLISHING
- SAWING
- ROUTERING / PLANING
- CLEANING
- HEAT GUN / LASERS
- PNEUMATIC TOOLS
- GARDEN TOOLS
- GENERATORS

DCU180

18V LXT Battery Powered Wheelbarrow

Moving cart powered by one or two LXT Li-ion batteries

Two variations: Carrier type and Bucket type



Wheelbarrow with flat tray

Flat tray (Part no: 199009-8)
Size width is adjustable. If you remove Side pipes, big size materials can be loaded.



Wheelbarrow with bucket tray

Bucket tray (Part no: 199008-0)
can load sand, gravel, powder etc.



(Please note Flat bed tray or Bucket tray will not be supplied with the wheelbarrow and need to be ordered separately)



Able to run with even one battery thanks to parallel battery connection.



Detachable Rear wheel



After removing rear wheels and installing Foot (left/ right), the cart can be used as a unicycle.

LED lights



- illuminate front area
- Battery case section is equipped with On-off switch

Foldable handle



can save the storage space.

BL MOTOR

High operating efficiency

Outer Rotor BL Motor provides high operating efficiency

XPT

Extreme Protection Technology



Specifications:-



Max Run Time (min)	with BL1860B: 120
Max Load Capacity	130 kg (290 lbs.)
Traveling Speed	Forward, High / Low: 0 - 3.5 / 0 - 1.5 km/h Reverse: 0 - 1 km/h
Max Climbing Capacity	12°
Dimensions (L x W x H)	When carrier is installed / During operation: 1,315x1,060x900 mm
Net weight	44.8 kg

Standard Equipment: Lock Key, Support Legs, Wrenches

AVAILABLE VARIANTS		
5.0Ah	3.0Ah	"Z" VARIANT
-	-	DCU180 Z TOOL ONLY (DOES NOT INCLUDE BATTERY / CHARGER / FLAT OR BUCKET TRAY)

14.4V Lithium-ion Battery Tools **LXT**

14.4V

LITHIUM-ION

DDF446 13mm (1/2") Acc Pg. A024-060 **440**

14.4V LXT - Lithium-ion Cordless Driver Drill

High power and lightweight.

- High power, compact and lightweight 4-pole motor.
- Mechanical 2-speed gearing.
- Single sleeve keyless chuck enables easy bit installation/removal with one hand.
- All metal gear construction ensures high transmission durability.
- LED Job light with afterglow function.

Specifications:-

Capacity	Steel : 13mm (1/2") Wood : 38mm (1-1/2")
No load speed (rpm)	Hi : 0-1,500 Lo : 0-400
Max. fastening torque	Hard / Soft : 44 / 30N m
Dimensions (L x W x H)	192x79x251mm (7-9/16"x3-1/8"x9-7/8")
Net weight	1.7kg (3.7lbs)

Standard Equipment: (+) Bit and Belt clip.

AVAILABLE VARIANTS	
3.0Ah	1.5Ah
DDF446 RFE INCLUDES 2 BATTERIES / 1 CHARGER / PLASTIC CARRYING CASE	DDF446 RYE INCLUDES 2 BATTERIES / 1 CHARGER / PLASTIC CARRYING CASE

DHP446 13mm (1/2") Acc Pg. A024-060 **440**

14.4V LXT - Lithium-ion Cordless Percussion Driver Drill

High power and lightweight.

- High power, compact and lightweight 4-pole motor.
- Mechanical 2-speed gearing.
- Single sleeve keyless chuck enables easy bit installation/removal with one hand.
- All metal gear construction ensures high transmission durability.
- LED Job light with afterglow function.

Specifications:-

Capacity	Steel : 13mm (1/2") Wood : 38mm (1-1/2") Masonry : 13mm (1/2")
Impacts per minute (ipm)	Hi : 0-22,500 Lo : 0-6,000
No load speed (rpm)	Hi : 0-1,500 Lo : 0-400
Max. fastening torque	Hard / Soft : 44 / 30N m
Dimensions (L x W x H)	206x79x251mm (8-1/8"x3-1/8"x9-7/8")
Net weight	1.7kg (3.8lbs)

Standard Equipment: (+) Bit and Belt clip.

AVAILABLE VARIANTS	
3.0Ah	1.5Ah
DHP446 RFE INCLUDES 2 BATTERIES / 1 CHARGER / PLASTIC CARRYING CASE	DHP446 RYE INCLUDES 2 BATTERIES / 1 CHARGER / PLASTIC CARRYING CASE

DTD134 Acc Pg. A024-031 **440**

14.4V LXT - Lithium-ion Cordless Impact Driver

Enhanced dust and drip-proof performance.

- Compact design with a short overall length of 138mm (5-7/16").
- Max fastening torque: 155N.m (1,370 in.lbs).
- The power remaining in the battery can be indicated in 3 stages simply by pushing a button.
- Ergonomically designed rubberized grip provides more control and comfort.

Specifications:-

Capacity	Machine screw : M4 - M8 (5/32" - 5/16") Standard bolt : M5 - M14 (3/16" - 9/16") High tensile bolt : M5 - M12 (3/16" - 1/2") Coarse thread (in length): 22 - 125mm (7/8" - 4-7/8")
Impacts per minute (ipm)	0-3,200
No load speed (rpm)	0-2,400
Max. fastening torque	155N m (1,370in.lbs)
Dimensions (L x W x H)	138x79x238mm (5-7/16"x3-1/8"x9-3/8")
Net weight	1.2kg (2.6lbs)

Standard Equipment: (+) Bit and Belt clip.

AVAILABLE VARIANTS	
3.0Ah	1.5Ah
DTD134 RFE INCLUDES 2 BATTERIES / 1 CHARGER / PLASTIC CARRYING CASE	-

- CORDLESS
- FIXING / FASTENING
- DRILLING / IMPACT DRILLING
- CONCRETE DRILLING / DEMOLITION
- CUTTING [CONCRETE / MASONRY / METAL]
- MULTI TOOL
- GRINDING
- SANDING / POLISHING
- SAWING
- ROUTERING / PLANING
- CLEANING
- HEAT GUN / LASERS
- PNEUMATIC TOOLS
- GARDEN TOOLS
- GENERATORS

Expand Your Lithium Line Up

12V^{max}
LITHIUM-ION

CXT



CXT

**Charging
30 minutes**

DC10SB (12VMAX fast charger)
to fully charge a 2.0Ah slide
Li-ion battery



CXT Charger: Developed specially for charging the slide
Li-ion batteries of new 12VMAX platform



Fast Charging 30 minutes

DC18RE / DC10SB

to fully charge a 2.0Ah slide Li-ion battery



Li-ion Battery CXT BATTERY AVAILABLE IN 4.0Ah & 2.0Ah

Multi-Contact Slide-type Terminal

- Ensures stable contact with tool even under extreme vibration.
- Allows tools to be equipped with an ergonomic handle design.



Battery fuel gauge

The power remaining in the battery can be indicated in 4 stages simply by pushing a button.



Battery fuel gauge (4 stage LED)

Push button

DC18RE Charges LXT and CXT battery alternatively

Compatible batteries are: 14.4V/18V LXT batteries & 12V MAX CXT batteries.



Optimum Charging System

Forced air cooling system (DC10SB only)

- Stand-by time until the charge starts can be greatly shortened by using charger DC10SB equipped with a built-in cooling fan.
- Effectively cools down every battery cell with the forced air cooling system and the heat sinks.

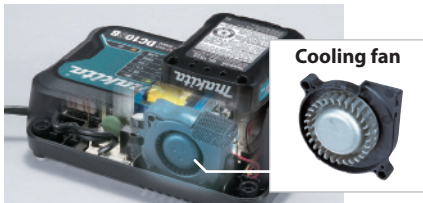

Cooling fan

Charging status indicator

Shows the charging status of a battery being charged in 2 stages: less than 80% and 80% or more.



Wall mountable for charging

Can be mounted on the wall for charging, allowing the user to obtain maximum working space on workbench.



12V MAX Slide Battery



Two Port Charger (LXT + CXT)

Fast Charger (CXT)

Standard Charger (CXT)

DC18RE

DC10SB

DC10WC

110 - 120 (2pin type) Part No.

197435-5

630967-4

220 - 240 (2pin type) Part No.

198576-0

220 - 240 (3pin type) Part No.

198447-1

198433-2

		2.0Ah	30 min	30 min	70 min
	BATTERY ID	BL1021B			
	Part No.	197396-9			
	PACKAGE	CARTON			
	FUEL GAUGE	✓			
		4.0Ah	60 min	60 min	130 min
	BATTERY ID	BL1041B			
	Part No.	197406-2			
	PACKAGE	CARTON			
	FUEL GAUGE	✓			

- CORDLESS
- FIXING / FASTENING
- DRILLING / IMPACT DRILLING
- CONCRETE DRILLING / DEMOLITION
- CUTTING (CONCRETE/ MASONRY/ METAL)
- MULTI TOOL
- GRINDING
- SANDING / POLISHING
- SAWING
- ROUTERING / PLANING
- CLEANING
- HEAT GUN / LASERS
- PNEUMATIC TOOLS
- GARDEN TOOLS
- GENERATORS

HR166D 16mm (Adapted for SDS-PLUS bits) Acc Pg. A062-079

12V MAX CXT Lithium-ion Cordless Rotary Hammer



Compact, lightweight "palm-size" design Rotary Hammer for ultimate usability: Suitable for upward and horizontal applications

- Vibration absorbing housing and ergonomic soft rubber grip design for vibration absorption and comfortable operation
- Close-to-hand gravity center for optimum balance and control
- High-efficiency drilling: Provides up to 50% more runtime, up to 40% more speed
- 1.1 Joules impact energy delivers high performance

Specifications:-

Impact Energy	1.0 J
Capacity	Concrete: 14 mm / Steel: 10 mm / Wood: 13 mm
Impacts Per Minute (IPM)	0 - 4,900
No Load Speed (RPM)	0 - 850
Vibration Level	Hammer Drilling Into Concrete: 6.5 m/s ² Drilling Into Metal: 3.0 m/s ² or less
Dimensions (L x W x H)	246x74x179 mm (with BL1021B)
Net weight	1.9 kg (with BL1021B)

Standard Equipment: Side Grip, Depth Gauge

Different types drill bits to use with SDS-PLUS Rotary Hammer for various applications

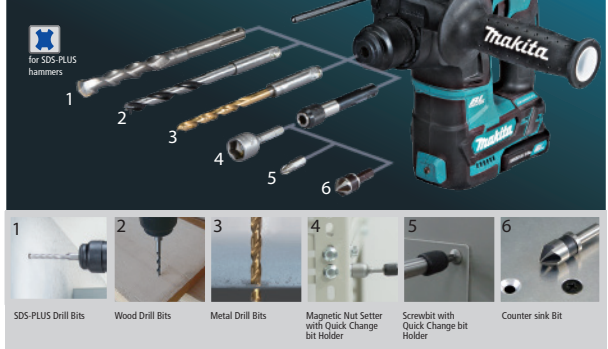

Optional Accessories: 65pcs SDS-PLUS rotary hammers drill bits set

- Part no: B-69478
- In makpac case
- Accessory set includes bits for drilling on metal, wood, masonry, screw bit and nutsetter for SDS-PLUS rotary hammer drill.



AVAILABLE VARIANTS		
4.0Ah	2.0Ah	"Z" Version
	HR166D WAJ INCLUDES 2 BATTERIES / 1 CHARGER / CARRYING CASE	HR166D Z TOOL ONLY (DOES NOT INCLUDE BATTERY / CHARGER OR CARRY CASE)

DF333D 10mm (3/8") Acc Pg. A024-060



Compact and ergonomic design with only 179mm length

- Ball bearing reduces chuck wobbling
- Slide style battery and improved ergonomic grip
- Variable 2-speed (0-450 & 0-1,700 RPM) for a wide range of drilling and fastening applications
- Increased motor power for higher application speed and max tightening torque

Specifications:-

Capacity	Steel / Wood: 10 / 21 mm
Chuck capacity	DF333D: 0.8 - 10 mm
No Load Speed (RPM)	High / Low: 0 - 1,700 / 0 - 450
Max Fastening Torque	Hard / Soft: 30 / 14 N m
Max lock torque	28 N m
Dimensions (L x W x H)	179x66x212 mm
Net weight	1.2 kg

Standard Equipment: Belt clip

AVAILABLE VARIANTS		
4.0Ah	2.0Ah	"Z" Version
	DF333D WAE INCLUDES 2 BATTERIES / 1 CHARGER / CARRYING CASE	DF333D Z TOOL ONLY (DOES NOT INCLUDE BATTERY / CHARGER OR CARRY CASE)

DF332D 10mm (3/8") Acc Pg. A024-060



More compact and more work amount thanks to the newly developed brushless motor

- High rotational speed
- Best possible ergonomic handle for drilling/driving applications
- Battery protection circuit is activated on high battery temperature to protect the battery from damages due to overdischarge, high temperature or overload current.
- 10mm (3/8") single sleeve keyless drill chuck with click sound to indicate that drill bit is fully locked

Specifications:-

Capacity	Steel : 10mm (3/8") Wood : 28mm (1-1/8")
No load speed (rpm)	Hi : 0-1,500 / Lo : 0-450
Max tightening torque	Hard / Soft : 35 / 21N m
Dimensions (L x W x H)	154x66x217mm (6-1/6"x2-5/8"x8-1/2")
Net weight	1.0kg (2.3lbs)

Standard Equipment: Belt clip, Phillips bit

AVAILABLE VARIANTS		
4.0Ah	2.0Ah	"Z" Version
	DF332D WAE INCLUDES 2 BATTERIES / 1 CHARGER / CARRYING CASE	DF332D Z TOOL ONLY (DOES NOT INCLUDE BATTERY / CHARGER OR CARRY CASE)

DF331D 10mm (3/8") Acc Pg. A024-060

12V MAX CXT Lithium-ion Cordless Driver Drill



Increased motor power for higher application speed and max tightening torque

- Best possible ergonomic handle for drilling/driving applications
- Battery protection circuit is activated on high battery temperature to protect the battery from damages due to overdischarge, high temperature or overload current.
- 10mm (3/8") single sleeve keyless drill chuck with click sound to indicate that drill bit is fully locked
- Single LED job light with pre-glow and afterglow functions

Specifications:-



Capacity	Steel : 10mm (3/8") Wood : 21mm (13/16")
No load speed (rpm)	Hi : 0-1,700 / Lo : 0-450
Max tightening torque	Hard / Soft : 30 / 14N m
Dimensions (L x W x H)	189x66x209mm (7-7/16"x2-5/8"x8-1/4")
Net weight	1.1kg (2.4lbs)

Standard Equipment: Belt clip, Phillips bit

AVAILABLE VARIANTS

4.0Ah	2.0Ah	"Z" Version
	DF331D WAE INCLUDES 2 BATTERIES / 1 CHARGER / CARRYING CASE	DF331D Z TOOL ONLY (DOES NOT INCLUDE BATTERY / CHARGER OR CARRY CASE)

HP332D 10mm (3/8") Acc Pg. A024-060

12V MAX CXT Lithium-ion Cordless Percussion Driver Drill



More compact and more work amount thanks to the newly developed brushless motor and 10.8V slide Li-ion battery

- High rotational speed
- Best possible ergonomic handle for drilling/driving applications
- Battery protection circuit is activated on high battery temperature to protect the battery from damages due to overdischarge, high temperature or overload current.
- 10mm (3/8") single sleeve keyless drill chuck with click sound to indicate that drill bit is fully locked
- Single LED job light with pre-glow and afterglow functions

Specifications:-



Capacity	Steel : 10mm (3/8") Wood : 28mm (1-1/8") Masonry : 8mm (5/16")
Impacts per minute (ipm)	Hi : 0-22,500 / Lo : 0-6,750
No load speed (rpm)	Hi : 0-1,500 / Lo : 0-450
Max tightening torque	Hard / Soft : 35 / 21N m
Dimensions (L x W x H)	168x66x217mm (6-5/8"x2-5/8"x8-1/2")
Net weight	1.1kg (2.5lbs)

Standard Equipment: Belt clip, Phillips bit

AVAILABLE VARIANTS

4.0Ah	2.0Ah	"Z" Version
	HP332D WAE INCLUDES 2 BATTERIES / 1 CHARGER / CARRYING CASE	HP332D Z TOOL ONLY (DOES NOT INCLUDE BATTERY / CHARGER OR CARRY CASE)

HP333D 10mm (3/8") Acc Pg. A024-060

12V MAX CXT Lithium-ion Cordless Percussion Driver Drill



Compact and ergonomic design with only 193mm length

- Ball bearing reduces chuck wobbling
- Slide style battery and improved ergonomic grip
- Variable 2-speed (0-450 & 0-1,700 RPM) for a wide range of drilling, fastening and hammer drilling applications
- Increased motor power for higher application speed and max tightening torque

Specifications:-



Capacity	Steel / Wood / Masonry: 10 / 21 / 8 mm
Impacts per minute (ipm)	High / Low: 0 - 25,500 / 0 - 6,750
No load speed (rpm)	High / Low: 0 - 1,700 / 0 - 450
Max tightening torque	Hard / Soft: 30 / 14 N m
Max lock torque	28 N m
Dimensions (L x W x H)	193x66x212 mm
Net weight	1.3 kg

Standard Equipment: Belt clip

AVAILABLE VARIANTS

4.0Ah	2.0Ah	2.0Ah	"Z" Version
-	HP333D WAX1 INCLUDES 74PCS ACC SET + 2 BATTERIES / 1 CHARGER / CARRYING CASE	HP333D WAE INCLUDES 2 BATTERIES / 1 CHARGER / CARRYING CASE	HP333D Z TOOL ONLY (DOES NOT INCLUDE BATTERY / CHARGER OR CARRY CASE)

HP333D WAX1 (with Accessories kit)

74pcs ACCESSORIES KIT

- 2pcs of Phillips bit (long)
- 2pcs of Pozi bit (long)
- 2pcs of Torx bit (long)
- 2pcs of Slotted bit (long)
- 10pcs of Phillips bit
- 8pcs of Slotted bit
- 10pcs of Pozi bit
- 8pcs of Torx bit
- 4pcs of Hex bit
- 4pcs of Socket
- 5pcs of Masonry bit
- 8pcs of H.S.S drill bit
- 5pcs of Wood drill bit
- 2pcs of Flat bit
- 1pc of Magnetic bit holder
- 1pc of Countersink

CARRYING CASE



2 BATTERIES OF 2.0Ah

1 CHARGER

Percussion Driver Drill

CORDLESS

FIXING / FASTENING

DRILLING / IMPACT DRILLING

CONCRETE DRILLING / DEMOLITION

CUTTING [CONCRETE/ MASONRY/ METAL]

MULTI TOOL

GRINDING

SANDING / POLISHING

SAWING

ROUTERING / PLANING

CLEANING

HEAT GUN / LASERS

PNEUMATIC TOOLS

GARDEN TOOLS

GENERATORS

- CORDLESS
- FIXING / FASTENING
- DRILLING / IMPACT DRILLING
- CONCRETE DRILLING / DEMOLITION
- CUTTING (CONCRETE/ MASONRY/ METAL)
- MULTI TOOL
- GRINDING
- SANDING / POLISHING
- SAWING
- ROUTERING / PLANING
- CLEANING
- HEAT GUN / LASERS
- PNEUMATIC TOOLS
- GARDEN TOOLS
- GENERATORS

HP331D
Acc Pg. A024-060

12V MAX CXT Lithium-ion Cordless Percussion Driver Drill

Increased motor power for higher application speed and max tightening torque

- Best possible ergonomic handle for drilling/driving applications
- 10mm single sleeve keyless drill chuck with click sound to indicate that drill bit is fully locked
- Single LED job light with pre-glow and afterglow functions

Specifications:-

Capacity	Steel : 10mm (3/8")
	Wood : 21mm (13/16")
	Masonry : 8mm (5/16")
Impacts per minute (ipm)	Hi : 0-25,500 / Lo : 0-6,750
No load speed (rpm)	Hi : 0-1,700 / Lo : 0-450
Max tightening torque	Hard / Soft : 30 / 14N m
Dimensions (L x W x H)	201x66x209mm (7-7/8"x2-5/8"x8-1/4")
Net weight	1.1kg (2.5lbs)

Standard Equipment: Belt clip

AVAILABLE VARIANTS		
4.0Ah	2.0Ah	"Z" Version
HP331D WAE INCLUDES 2 BATTERIES / 1 CHARGER / CARRYING CASE	HP331D Z TOOL ONLY (DOES NOT INCLUDE BATTERY / CHARGER OR CARRY CASE)	



TD111D
Acc Pg. A024-036

12V MAX CXT Lithium-ion Cordless Impact Driver

Equipped with brushless motor and impact power selection has High/low also with A mode (Assist mode)

- Best possible ergonomic handle for screwdriving applications
- Modified motor delivers higher maximum torque
- Battery protection circuit is activated on high battery temperature to protect the battery from damages due to overdischarge, high temperature or overload current.
- Single LED job light with pre-glow and afterglow functions

Specifications:-

Capacity	Machine screw : M4 - M8mm (5/32" - 5/16")
	Standard bolt : M5 - M14 (3/16" - 9/16")
	High strength bolt : M5 - M12 (3/16" - 1/2")
	Coarse thread (in length): 22 - 90mm (7/8" - 3-1/2")
No load speed (rpm)	Hi: 0-3,000 Lo: 0-1,300
Impacts per minute (ipm)	Hi: 0-3,900, Lo: 0-1,600
Max tightening torque	135N m
Dimensions (L x W x H)	with BL1021B: 135x66x210mm
Net weight	0.97kg

Standard Equipment: Belt clip

AVAILABLE VARIANTS		
4.0Ah	2.0Ah	"Z" Version
TD111D WME INCLUDES 2 BATTERIES / 1 CHARGER / CARRYING CASE	TD111D WAE INCLUDES 2 BATTERIES / 1 CHARGER / CARRYING CASE	TD111D Z TOOL ONLY (DOES NOT INCLUDE BATTERY / CHARGER OR CARRY CASE)

TD110D
Acc Pg. A024-036

12V MAX CXT Lithium-ion Cordless Impact Driver

High power, Increased motor power for higher application speed and max tightening torque

- Best possible ergonomic handle for screwdriving applications
- Powered by slide Li-ion battery
- Battery protection circuit is activated on high battery temperature to protect the battery from damages due to overdischarge, high temperature or overload current.
- Single LED job light with pre-glow and afterglow functions

Specifications:-

Capacity	Machine screw : M4 - M8mm (5/32" - 5/16")
	Standard bolt : M5 - M12 (3/16" - 1/2")
	High strength bolt : M5 - M10 (3/16" - 3/8")
	Coarse thread (in length): 22 - 90mm (7/8" - 3-1/2")
No load speed (rpm)	0-2,600
Impacts per minute (ipm)	0-3,500
Max tightening torque	110N m
Dimensions (L x W x H)	153x66x204mm
Net weight	1.0kg

Standard Equipment: Belt clip

AVAILABLE VARIANTS		
4.0Ah	2.0Ah	"Z" Version
TD110D WAE INCLUDES 2 BATTERIES / 1 CHARGER / CARRYING CASE	TD110D Z TOOL ONLY (DOES NOT INCLUDE BATTERY / CHARGER OR CARRY CASE)	



TW161D (1/2") Acc Pg. A032-036

12V MAX CXT Lithium-ion Cordless Impact Wrench



Ultra compact design. High power impact wrench and ideal for working in tight spaces and overhead applications

- Brushless Motor delivers 165N-m Maximum fastening torque
- Reverse rotation auto-stop mode stops in 0.2 seconds after the bolt/nut loosened enough
- Aluminium hammer case creates the impression of rigidity of the machine
- Single LED job light with preglow and afterglow functions
- 2 stage impact power selection

Specifications:-

Fastening Capacities	Standard Bolt: M8 - M16 High Tensile Bolt: M6 - M12
Square Drive	12.7 mm (1/2")
No Load Speed (RPM)	High / Low: 0 - 2,400 / 0 - 1,300
Impacts Per Minute (IPM)	High / Low: 0 - 3,600 / 0 - 2,000
Max Fastening Torque	165 N m
Dimensions (L x W x H)	150x66x232 mm
Net weight	1.2 kg

Standard Equipment: Belt clip

AVAILABLE VARIANTS		
4.0Ah	2.0Ah	"Z" Version
TW161D SME INCLUDES 2 BATTERIES / 1 FAST CHARGER / CARRYING CASE	-	TW161D Z TOOL ONLY (DOES NOT INCLUDE BATTERY / CHARGER OR CARRY CASE)

DA332D 10mm Acc Pg. A024-060

12V MAX CXT Lithium-ion Cordless Angle Drill



Compact Angle Head Height & Center Height for Use in Close Quarters

- Up to 40% faster drilling and 380% longer runtime
- Slide style battery and improved ergonomic grip
- Part of the expanding 12V max CXT series, combining performance with superior ergonomics in a compact size
- Multi-contact terminals ensure stable contact with battery even under extreme vibration

Specifications:-

Capacity	Steel: 10 mm / Wood: 12 mm /
No Load Speed (RPM)	0 - 1,100
Head Height	63 mm (2-1/2")
Center Height	23.5 mm (15/16")
Dimensions (L x W x H)	with BL1021B : 313x68x86 mm
Net weight	1.2kg

Standard Equipment: Bit, Belt Clip, Chuck Key, Chuck Key Holder

AVAILABLE VARIANTS		
4.0Ah	2.0Ah	"Z" Version
	DA332D SAJ INCLUDES 2 BATTERIES / 1 CHARGER / MARKPACK CONNECTOR CASE	DA332D Z TOOL ONLY (DOES NOT INCLUDE BATTERY / CHARGER OR CARRY CASE)

WR100D Acc Pg. A032-036

12V MAX CXT Lithium-ion Cordless Ratchet Wrench



Equipped with lock-pin style ratchet mechanism is employed, allowing for use as a pass-through ratchet wrench to tighten 13mm nut onto M8 threaded rod

- Easy-to-grip small diameter grip for more comfort and control
- 47.5 N m of maximum torque and 0-800 RPM
- Fastens nuts on threaded rods

Forward / reverse rotation change

Turn the reversing lever to the A side for clockwise rotation or to the B side for counterclockwise rotation

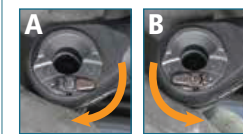

Compatible with variable sockets with socket adapter



Specifications:-

Capacity	Standard Bolt: M5 - M12 High Strength Bolt: M5 - M10
Square Drive	9.5 / 6.35 mm
No Load Speed (RPM)	0 - 800
Max Fastening Torque	47.5 N m
Vibration Level	2.5 m/s ² or less
Sound Pressure Level	74 dB(A)
Dimensions (L x W x H)	341x67x84 mm
Net weight	1.2 kg

AVAILABLE VARIANTS		
4.0Ah	2.0Ah	"Z" Version
WR100D SM INCLUDES 1 BATTERY / 1 CHARGER / TOOL BAG		WR100D Z TOOL ONLY (DOES NOT INCLUDE BATTERY / CHARGER OR CARRY CASE OR TOOL BAG)

CORDLESS

FIXING / FASTENING

DRILLING / IMPACT DRILLING

CONCRETE DRILLING / DEMOLITION

CUTTING [CONCRETE/ MASONRY/ METAL]

MULTI TOOL

GRINDING

SANDING / POLISHING

SAWING

ROUTERING / PLANING

CLEANING

HEAT GUN / LASERS

PNEUMATIC TOOLS

GARDEN TOOLS

GENERATORS

- CORDLESS
- FIXING / FASTENING
- DRILLING / IMPACT DRILLING
- CONCRETE DRILLING / DEMOLITION
- CUTTING (CONCRETE/ MASONRY/ METAL)
- MULTI TOOL
- GRINDING
- SANDING / POLISHING
- SAWING
- ROUTERING / PLANING
- CLEANING
- HEAT GUN / LASERS
- PNEUMATIC TOOLS
- GARDEN TOOLS
- GENERATORS

TL064D Acc Pg. A024-036

12V MAX CXT Lithium-ion Cordless Angle Impact Driver



Compact & lightweight right angle impact driver for fastening and loosening in tight spaces

- Variable speed for a range of applications from auto repair to cabinet installation
- Large conveniently located paddle switch for comfortable operation
- Over one foot of tool extension for extra reach into deep tight spaces

Specifications:- 

Capacity	Machine Screw: M4 - M8 (5/32" - 5/16") Standard Bolt: M4 - M12 (5/32" - 1/2") High Tensile Bolt: M4 - M8 (5/32" - 5/16") Coarse thread (in length): 22 - 75 mm (7/8" - 2-31/32")
Hex Shank	6.35 mm (1/4")
No Load Speed (RPM)	0 - 2,000
Impacts Per Minute (IPM)	0 - 3,000
Max Fastening Torque	60 N m
Dimensions (L x W x H)	361x66x86 mm
Net weight	1.6kg

Standard Equipment: Belt clip

AVAILABLE VARIANTS		
4.0Ah	2.0Ah	"Z" Version
		TL064D Z TOOL ONLY (DOES NOT INCLUDE BATTERY / CHARGER OR CARRY CASE)

TL065D Acc Pg. A032-036

12V MAX CXT Lithium-ion Cordless Impact Wrench



Compact & lightweight right angle impact wrench for fastening and loosening in tight spaces

- Variable speed for a range of applications from auto repair to product assembly
- Large conveniently located paddle switch for comfortable operation
- Over one foot of tool extension for extra reach into deep tight spaces

Specifications:- 

Capacity	Standard Bolt: M4 - M12 (5/32" - 1/2") High Tensile Bolt: M4 - M8 (5/32" - 5/16")
Square Drive	9.5 mm (3/8")
No Load Speed (RPM)	0 - 2,000
Impacts Per Minute (IPM)	0 - 3,000
Max Fastening Torque	60 N m
Dimensions (L x W x H)	361x66x86 mm
Net weight	1.6kg

Standard Equipment: Belt clip

AVAILABLE VARIANTS		
4.0Ah	2.0Ah	"Z" Version
		TL065D Z TOOL ONLY (DOES NOT INCLUDE BATTERY / CHARGER OR CARRY CASE)

TL064D / TL065D
Angle Impact Driver Angle Impact Wrench

Compact & Slim for Easy Handling

Head height
53mm

Center height
18mm

Max fastening torque
60_N·m

Lightweight
1.3_{kg}
(2.8lbs.) w/BL1016





Photo: TL064D

Accessories

Optional attachments for versatility

Straight head
Part No. 192440-7



Ratchet head
Part No. 192439-2



21mm

Socket Adapter for TL064D / TL065D

Part No. 134745-9
9.5mm (3/8")

Part No. 134746-7
12.7mm (1/2")

For fastening and loosening in tight spaces



Hex Shank:
6.35 mm (1/4") TL064D only



Square Drive: 9.5 mm (3/8")
TL065D only

TM30D Acc Pg. A089-098

12V MAX CXT Lithium-ion Cordless Multi Tool



High power, Wide selection of accessories available for various applications high cutting efficiency

- 12 angle setting of accessories at every 30° from 0° to 360°
- Ergonomically designed rubberized grip provides more control and comfort.
- Anti-restart function prevents accidental start-up.
- Variable speed control by dial

Specifications:-



Oscillations per minute (opm)	6,000-20,000
Dimensions (L x W x H)	277x65x98mm (10-7/8"x2-9/16"x3-7/8")
Net weight	1.1kg (2.4lbs)

Standard Equipment: Hex Wrench

AVAILABLE VARIANTS		
4.0Ah	2.0Ah	"Z" Version
	TM30D WAJ INCLUDES 2 BATTERIES / 1 CHARGER / MAKPACK CONNECTOR CASE	TM30D Z TOOL ONLY (DOES NOT INCLUDE BATTERY / CHARGER OR CARRY CASE)

CC301D 85mm Acc Pg. A103

12V MAX CXT Lithium-ion Cordless Cutter

Smooth and powerful cutting

- High rotational speed of 1,500RPM
- Compact design with an overall length of 313mm
- Ergonomically designed handles
- Water supply tank with large cap
- Bevel cuts up to 45 degrees
- Nickel-plated base for rust prevention

Specifications:-



Max cutting capacity	at 0 degrees : 25.5mm (1") at 45 degrees : 16.5mm (5/8")
Blade diameter	85mm (3-3/8")
No load speed (rpm)	1,600
Tank capacity	Water : 0.5L
Dimensions (L x W x H)	313x170x125mm
Net Weight	1.8kg

Standard Equipment: Diamond wheel, Hex Wrench, Water supply tank assembly

AVAILABLE VARIANTS		
4.0Ah	2.0Ah	"Z" Version
	CC301D WAE INCLUDES 2 BATTERIES / 1 CHARGER / CARRYING CASE	CC301D Z TOOL ONLY (DOES NOT INCLUDE BATTERY / CHARGER OR CARRY CASE)

SC103D

12V MAX CXT Lithium-ion Cordless Threaded Rod Cutter





More Compact & High Productivity with brushless motor

- Lightweight provides increased comfort for overhead cutting
- No spark, no deburring required and low noise
- Nut can be immediately mounted.
- Great tool balance and Lightweight - comfortable for overhead applications

Performs stable cutting even on the floor

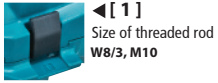
Rod guide
There are two rod guide positions.

Accessories

Long life cutter blade
High rigidity Double-edged blade

Clean cut surface
Burr-free cuts allow for easy nut tightening.

Type	Size	Part no:
Mild Steel - Stainless Steel	M6	199087-8
Mild Steel - Stainless Steel	M8	199085-2
Mild Steel	M10	199083-6

Specifications:-

Max Cutting Capacity	Mild Steel: M10 Stainless Steel: W3/8
Min. Cutting Length	20 mm
Work Amount (pcs)	M10 (Mild Steel) w/BL1041B: 550
Dimensions (L x W x H)	180x107x289 mm
Net weight	2.8 kg

Standard Equipment: Depth Gauge, Hex Wrench,

AVAILABLE VARIANTS		
4.0Ah	2.0Ah	"Z" VARIANT
		SC103D ZJ TOOL + MAKPACK CASE ONLY (DOES NOT INCLUDE BATTERY / CHARGER)

Cutting capacities			
	M10	M8	M6
Mild Steel	✓	✓	✓
Stainless steel	—	✓	✓

*Depending on the type of steel threaded rod, deburring may be necessary after cutting.

- CORDLESS
- FIXING / FASTENING
- DRILLING / IMPACT DRILLING
- CONCRETE DRILLING / DEMOLITION
- CUTTING [CONCRETE/ MASONRY/ METAL]
- MULTI TOOL
- GRINDING
- SANDING / POLISHING
- SAWING
- ROUTERING / PLANING
- CLEANING
- HEAT GUN / LASERS
- PNEUMATIC TOOLS
- GARDEN TOOLS
- GENERATORS

- CORDLESS
- FIXING / FASTENING
- DRILLING / IMPACT DRILLING
- CONCRETE DRILLING / DEMOLITION
- CUTTING [CONCRETE/ MASONRY/ METAL]
- MULTI TOOL
- GRINDING
- SANDING / POLISHING
- SAWING
- ROUTERING / PLANING
- CLEANING
- HEAT GUN / LASERS
- PNEUMATIC TOOLS
- GARDEN TOOLS
- GENERATORS

CP100D 85mm

12V MAX CXT Lithium-ion Cordless Multi Cutter



High power, Lightweight & Compact for easy maneuverability

- Auto self-sharpening function maintains sharp cutting performance
- Large Work Amount on a Single Battery Charge
- High power satisfies even professional needs such as carpet contractors
- Cuts thin and thick material up to 6 mm such as cardboard, carpet, fabrics, leather, CD, DVD & Blu-ray
- Handy size for easy maneuverability in various applications for home and professional use

Specifications:-

Max Cutting Capacity	6 mm (1/4")
No Load Speed (RPM)	300
Dimensions (L x W x H)	with BL1021B: 272x66x120 mm
Net weight	0.72kg

AVAILABLE VARIANTS		
4.0Ah	2.0Ah	"Z" Version
	CP100D SA1J INCLUDES 1 BATTERY / 1 CHARGER / MAKPACK CONNECTOR CASE	CP100D Z TOOL ONLY (DOES NOT INCLUDE BATTERY / CHARGER OR CARRY CASE)



Accessories
Blade set

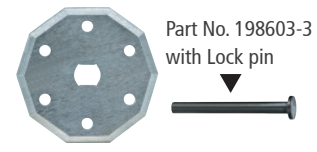

SD100D

12V MAX CXT Lithium-ion Drywall Cutter



Excellent tool balance allows easy overhead application

- Ideal for cutting holes in drywalls when setting ceiling lights, air vents etc.
- More suitable for straight cuts compared with general cut-out tools
- Dust box designed to catch dust in overhead applications for comfortable work

Accessories

Image	Suitable for Models	For Material	Part No
	DSD180, SD100D	Dry wall	B-49703
	DSD180, SD100D	Wood	B-49719

Specifications:-

Strokes Per Minute (SPM)	0 - 6,000
Length of stroke	6 mm (1/4")
Capacity	Drywall: 30 mm Wood: 15 mm
Dimensions (L x W x H)	239x79x266 mm
Net weight	1.6 kg

Standard Equipment: Base Cover, Hex Wrench

AVAILABLE VARIANTS		
4.0Ah	2.0Ah	"Z" Version
		SD100D ZJ TOOL WITH CARRYCASE ONLY (DOES NOT INCLUDE BATTERY / CHARGER)

HS301D 85mm Acc Pg. A145

12V MAX CXT Lithium-ion Cordless Circular Saw



High power, high cutting efficiency

- Ergonomically designed handle with soft grip; provides comfortable grip and more control while minimizing hand fatigue and pain.
- Battery protection circuit; is activated by high battery temperature to protect the battery from damages due to overdischarge, high temperature or overload current.
- On-tool storage for hex wrench
- Blower function; blows sawdust off the cut line ahead for a better cutting view.

Specifications:-

Max cutting capacity	at 0 degrees : 25.5mm (1") at 45 degrees : 16.5mm (5/8")
Blade diameter	85mm (3-3/8")
No load speed (rpm)	1,500
Dimensions (L x W x H)	313x170x155mm (12-3/8"x6-11/16"x6-1/8")
Net weight	1.6kg (3.5lbs)

Standard Equipment: Hex wrench, Dust nozzle

AVAILABLE VARIANTS		
4.0Ah	2.0Ah	"Z" Version
	HS301D WAE INCLUDES 2 BATTERIES / 1 CHARGER / CARRYING CASE	HS301D Z TOOL ONLY (DOES NOT INCLUDE BATTERY / CHARGER OR CARRY CASE)

JV103D Acc Pg. A153-160

12V MAX CXT Lithium-ion Cordless Jig Saw



Top handle model most often used for single hand operation

- Faster Cutting and Longer Runtime
- Disabling soft no-load rotation function in operator's preference
- Soft no-load rotation reduces vibration and aligns blade with the cutting line easily
- Toolless blade clamp for easy blade change
- Independent dust nozzle can be attached for connection to Makita vacuum cleaner and doesn't require to be removed even when bevel cutting

Specifications:-

Capacity	Wood / Aluminum / Mild Steel: 90 / 20 / 10 mm
Length of stroke	23 mm
Strokes per minute (spm)	800 - 3,000
Dimensions (L x W x H)	237x76x206 mm
Net weight	1.9 kg

Standard Equipment: Hex Wrench, Dust Nozzle, Dust Cover, Cover Plate

AVAILABLE VARIANTS		
4.0Ah	2.0Ah	"Z" Version
	JV103D SA1J INCLUDES 1 BATTERY / 1 CHARGER / MAKPACK CONNECTOR CASE	JV103D Z TOOL ONLY (DOES NOT INCLUDE BATTERY / CHARGER OR CARRY CASE)

JV102D (Barrel handle) Acc Pg. A153-160

12V MAX CXT Lithium-ion Cordless Jig Saw



The barrel grip with raised front pommel which allows two-handed control of the machine

- Faster Cutting and Longer Runtime
- Disabling soft no-load rotation function in operator's preference
- Soft no-load rotation reduces vibration and aligns blade with the cutting line easily
- Toolless blade clamp for easy blade change
- Independent dust nozzle can be attached for connection to Makita vacuum cleaner and doesn't require to be removed even when bevel cutting

Specifications:-

Max cutting capacity	Wood / Aluminum / Mild Steel: 90 / 20 / 10 mm
Length of Stroke	23 mm
Strokes Per Minute (SPM)	800 - 3,000
Dimensions (L x W x H)	237x76x186 mm
Net weight	1.9 kg

Standard Equipment: Hex Wrench, Dust Nozzle, Dust Cover, Cover Plate

AVAILABLE VARIANTS		
4.0Ah	2.0Ah	"Z" Version
	JV102D SA1J INCLUDES 1 BATTERY / 1 CHARGER / MAKPACK CONNECTOR CASE	JV102D Z TOOL ONLY (DOES NOT INCLUDE BATTERY / CHARGER OR CARRY CASE)

JV101D Acc Pg. A153-160

12V MAX CXT Lithium-ion Cordless Jig Saw



Compact and lightweight body optimum for light duty cutting

- Ergonomically designed handle provides more control and comfort.
- Rigid aluminum base bevels 0 to 45 degrees left and right
- Change lever for 3 orbital settings and straight cutting

Specifications:-

Capacity	Wood : 65mm (2-9/16") Steel : 2mm (1/16")
Length of stroke	18mm (11/16")
Strokes per minute (spm)	0-2,850
Dimensions (L x W x H)	232x76x196mm
Net weight	1.8kg

Standard Equipment: Hex wrench

AVAILABLE VARIANTS		
4.0Ah	2.0Ah	"Z" Version
	JV101D WAE INCLUDES 2 BATTERIES / 1 CHARGER / CARRYING CASE	JV101D Z TOOL ONLY (DOES NOT INCLUDE BATTERY / CHARGER OR CARRY CASE)

JR105D Acc Pg. A153-160

12V MAX CXT Lithium-ion Cordless Recipro Saw



Two switches (Trigger switch and Paddle switch) in different positions allow various grip positions for easier operation using either trigger.

- Screw-down type blade clamp compatible with both Recipro saw / Jig saw blades
- Best possible ergonomic handle with soft grip fits your hand perfectly to provide maximum comfort and control.
- Battery protection circuit is activated on high battery temperature to protect the battery from damages due to over-discharge, high temperature or overload current.

Specifications:-

Capacity	Pipe : 50mm (2") Wood : 50mm (2")
Length of stroke	13mm (1/2")
Strokes per minute (spm)	0-3,300
Dimensions (L x W x H)	376x66x186mm
Net weight	1.3kg

Standard Equipment: Hex wrench, Recipro saw blades

AVAILABLE VARIANTS		
4.0Ah	2.0Ah	"Z" Version
	JR105D WAE INCLUDES 2 BATTERIES / 1 CHARGER / CARRYING CASE	JR105D Z TOOL ONLY (DOES NOT INCLUDE BATTERY / CHARGER OR CARRY CASE)

- CORDLESS
- FIXING / FASTENING
- DRILLING / IMPACT DRILLING
- CONCRETE DRILLING / DEMOLITION
- CUTTING [CONCRETE / MASONRY / METAL]
- MULTI TOOL
- GRINDING
- SANDING / POLISHING
- SAWING
- ROUTERING / PLANING
- CLEANING
- HEAT GUN / LASERS
- PNEUMATIC TOOLS
- GARDEN TOOLS
- GENERATORS

CORDLESS
FIXING / FASTENING
DRILLING / IMPACT DRILLING
CONCRETE DRILLING / DEMOLITION
CUTTING (CONCRETE/ MASONRY/ METAL)
MULTI TOOL
GRINDING
SANDING / POLISHING
SAWING
ROUTERING / PLANING
CLEANING
HEAT GUN / LASERS
PNEUMATIC TOOLS
GARDEN TOOLS
GENERATORS

CG100D

12V MAX CXT Lithium-ion Cordless Caulking Gun



Excellent work efficiency.

- Variable speed control by dial and trigger switch for maximum control of sealant flow rate.
- 300ml and 600ml size holder can be used.
- Anti-drip function stops excess from oozing out just on release of the switch trigger.
- Rubberized soft grip provides comfortable grip and better control.

Specifications:-

Max pushing force	5,000 N
No load speed	0 - 28 mm/sec. (0 - 66 in/min.)
Holder Size	300, 600, 800 mL
Dimensions (L x W x H)	404x108x259 mm
Net weight	1.9kg

Standard Equipment: Holder Set A, Safety Goggles

AVAILABLE VARIANTS

4.0Ah	2.0Ah	"Z" VARIANT
		CG100D ZAK TOOL WITH PLASTIC CARRY CASE (DOES NOT INCLUDE BATTERY / CHARGER)

Accessories

Standard Accessory

300ml size Holder Holder Set A (Part No. 196351-8)



Piston A

Optional Accessory

600ml size Holder Holder Set B (Part No. 196352-6)

Holder B set



Piston A, B, C

PT354D

12V MAX CXT Lithium-ion Cordless Pin Nailer



Low Reaction Force Mechanism Enables Easier Long Pin Nailing

- High-Quality Finish
- Easy-to-see slim nose tip allows quick and easy access to a desired fastening point
- Nails can be fired in the groove of baseboard
- Contact arm mechanism enables "continuous nailing" and "drag nailing"

Accessories

Pin Nails (optional)

Length (mm)	Pcs/Pkg	Part No.
18mm	10,000	F-31825
25mm	10,000	F-31838
30mm	10,000	F-31841
35mm	10,000	F-31854

Specifications:-

Capacity	Length: 15, 18, 25, 30, 35 mm Dia.: 0.6 mm / Gauge: 23 Ga
Magazine Capacity	120
Dimensions (L x W x H)	231x66x226 mm
Net weight	1.8kg

Standard Equipment: Nose Adapter, Safety Goggles, Belt Clip, Hex Wrench

AVAILABLE VARIANTS

4.0Ah	2.0Ah	"Z" Version
		PT354D Z TOOL ONLY (DOES NOT INCLUDE BATTERY / CHARGER OR CARRY CASE)

ST113D

12V MAX CXT Lithium-ion Cordless Stapler



More Compact and lightweight Stapler

- Operable in either way of "contact actuation" or "single sequential actuation"
- Contact actuation mode drives staples repetitively for quick operation
- Single sequential actuation mode drives one staple by one sequential operation

Accessories

Staples (optional)

Length (mm)	Pcs/Pkg	Part No.
7 x 10	25,000	F-81518
10 x 10	15,000	F-81521

Driving depth adjuster set 197731-1 (optional)

Specifications:-

Staple	Width: 10 mm Length: 7 - 10 mm Gauge: 0.5 x 0.7 mm
Magazine Capacity	150 (max 160)
Dimensions (L x W x H)	211x81x159 mm
Net weight	1.3 kg

Standard Equipment: Safety Goggles, Belt Clip

AVAILABLE VARIANTS

4.0Ah	2.0Ah	"Z" Version
		ST113D Z TOOL ONLY (DOES NOT INCLUDE BATTERY / CHARGER OR CARRY CASE)

SK105D / SK105GD / SK106D / SK106GD
Laser Series powered by 12V Li-ion CXT Batteries



Line beam brightness selection (Bright mode and Eco mode)

Rechargeable Red Cross Line Laser

Cross line + Point

SK106D

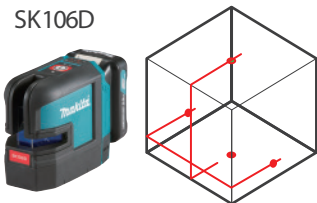

2 - LINES (Horizontal line / Vertical line)
4 - POINTS (Left/Right/Upper/Lower directions)

Cross line

SK105D



2 - LINES (Horizontal line
and Vertical line)

Rechargeable Green Cross Line Laser

Cross line + Point

SK106GD



2 - LINES (Horizontal line / Vertical line)
4 - POINTS (Left/Right/Upper/Lower directions)

Cross line

SK105GD

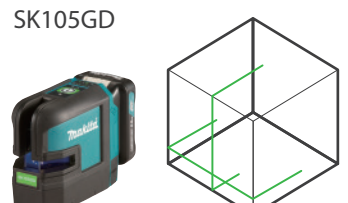

2 - LINES (Horizontal line
and Vertical line)

DC Jack

Allows to be charged from LXT batteries by using USB adapter ADP05 and power supply cable



Power cable
(part no: 199178-5)
and batteries are optional

Pendulum lock



Lock switch

Pendulum lock enables slope incline applications for increased versatility

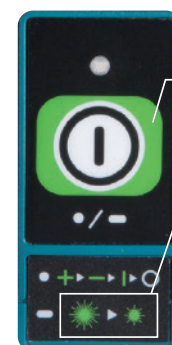

Laser line selection
and on / off switch

Brightness indicator



Bright
▼
Eco mode

CORDLESS
FIXING / FASTENING
DRILLING / IMPACT DRILLING
CONCRETE DRILLING / DEMOLITION
CUTTING (CONCRETE/ MASONRY/ METAL)
MULTI TOOL
GRINDING
SANDING / POLISHING
SAWING
ROUTERING / PLANING
CLEANING
HEAT GUN / LASERS
PNEUMATIC TOOLS
GARDEN TOOLS
GENERATORS

SK106GD
Acc Pg. A199

12V MAX CXT Lithium-ion Rechargeable 4-point Cross Line Laser

GREEN LASER

Bright 525nm class II green laser with measuring range upto 35m and with 3±mm / 10m for best-in-class accuracy

- High brightness green laser for increased visibility at bright site
- External Power Supply Jack for LXT Battery Use
- Line visibility range up to 35 m / 80 m (with Receiver)
- Pendulum lock enables slope incline applications for increased versatility; Offers added protection of laser diode during transport and storage

Specifications:-

Measuring range	Up to: 35 m
Measuring range w/ detector	Up to: 80 m
Leveling accuracy	±3 mm / 10 m
Self-leveling range	±4°
Laser fan angle	Horizontal: 180° / Vertical: 170°
Number of laser points / Lines	4 / 2
Laser type	Laser class 2: 525 nm
Operating temperature	-10 - 50 °C
Operating Time (Approx. Hours)	7 - 20hrs
Dimensions (L x W x H)	138x64x102 mm (with 2.0Ah battery)
Net weight	0.48kg (without battery)

Standard Equipment: Soft bag, Adapter, Target Plate

AVAILABLE VARIANTS		
4.0Ah	2.0Ah	"Z" Version
		SK106GD Z TOOL ONLY (DOES NOT INCLUDE BATTERY / CHARGER OR CARRY CASE)

SK106D
Acc Pg. A199

12V MAX CXT Lithium-ion Rechargeable 4-point Cross Line Laser

RED LASER



Bright 635nm class II red laser with measuring range upto 25m and with 3±mm / 10m for best-in-class accuracy

- External Power Supply Jack for LXT Battery Use
- Line visibility range up to 35 m / 80 m (with Receiver)
- Pendulum lock enables slope incline applications for increased versatility; Offers added protection of laser diode during transport and storage

Specifications:-

Measuring range	Up to: 25 m
Measuring range w/ detector	Up to: 80 m
Leveling accuracy	±3 mm / 10 m
Self-leveling range	±4°
Laser fan angle	Horizontal: 180° / Vertical: 170°
Number of laser points / Lines	4 / 2
Laser type	Laser class 2: 635nm
Operating temperature	-10 - 50 °C
Operating Time (Approx. Hours)	15 - 40hrs
Dimensions (L x W x H)	138x64x102 mm (with 2.0Ah battery)
Net weight	0.48kg (without battery)



Standard Equipment: Soft bag, Adapter, Target Plate

AVAILABLE VARIANTS		
4.0Ah	2.0Ah	"Z" Version
		SK106D Z TOOL ONLY (DOES NOT INCLUDE BATTERY / CHARGER OR CARRY CASE)

SK105GD
Acc Pg. A199

12V MAX CXT Lithium-ion Rechargeable Cross Line Laser

GREEN LASER

Bright 525nm class II green laser with measuring range upto 35m and with 3±mm / 10m for best-in-class accuracy

- High brightness green laser for increased visibility at bright site
- External Power Supply Jack for LXT Battery Use
- Line visibility range up to 35 m / 80 m (with Receiver)
- Pendulum lock enables slope incline applications for increased versatility; Offers added protection of laser diode during transport and storage

Specifications:-

Measuring range	Up to: 35 m
Measuring range w/ detector	Up to: 80 m
Leveling accuracy	±3 mm / 10 m
Self-leveling range	±4°
Laser fan angle	Horizontal: 180° / Vertical: 160°
Number of laser lines	2
Laser type	Laser class 2: 525 nm
Operating temperature	-10 - 50 °C
Operating Time (Approx. Hours)	7 - 20hrs
Dimensions (L x W x H)	138x64x102 mm (with 2.0Ah battery)
Net weight	0.46 kg (without battery)



Standard Equipment: Soft bag, Adapter, Target Plate

AVAILABLE VARIANTS		
4.0Ah	2.0Ah	"Z" Version
		SK105GD Z TOOL ONLY (DOES NOT INCLUDE BATTERY / CHARGER OR CARRY CASE)

SK105D
Acc Pg. A199

12V MAX CXT Lithium-ion Rechargeable Cross Line Laser

RED LASER

Bright 635nm class II red laser with measuring range upto 25m and with 3±mm / 10m for best-in-class accuracy

- External Power Supply Jack for LXT Battery Use
- Line visibility range up to 35 m / 80 m (with Receiver)
- Pendulum lock enables slope incline applications for increased versatility; Offers added protection of laser diode during transport and storage

Specifications:-

Measuring range	Up to: 25 m
Measuring range w/ detector	Up to: 80 m
Leveling accuracy	±3 mm / 10 m
Self-leveling range	±4°
Laser fan angle	Horizontal: 180° / Vertical: 160°
Number of laser lines	2
Laser type	Laser class 2: 635nm
Operating temperature	-10 - 50 °C
Operating Time (Approx. Hours)	15 - 40hrs
Dimensions (L x W x H)	138x64x102 mm (with 2.0Ah battery)
Net weight	0.46 kg (without battery)

Standard Equipment: Soft bag, Adapter, Target Plate

AVAILABLE VARIANTS		
4.0Ah	2.0Ah	"Z" Version
		SK105D Z TOOL ONLY (DOES NOT INCLUDE BATTERY / CHARGER OR CARRY CASE)

SK312GD

Acc Pg. A199

12V MAX CXT Lithium-ion Rechargeable Green Multi Line Laser



- Horizontal line / horizontal/vertical line / 3-vertical line/horizontal line (Loopback switch system)
- High accuracy +/- 1 mm @ 10 m
- Up to 28 hours of continuous illumination in high visibility mode with BL1041B
- Self-Leveling Horizontal/Vertical Cross Line laser

Specifications:-

Leveling accuracy	±1 mm / 10 m
Self-leveling range	±2°
Laser fan angle	Horizontal: 110° / Vertical: 130°
Number of laser lines	3
Laser type	Laser class 2: 515 nm
Operating temperature	-10 - 40 °C
Tripod thread	5/8"
Protection class	IP54
Operating Time (Approx. Hours)	10-28
Dimensions (L x W x H)	w/ BL1016/BL1021B: 122x110x225 mm
Net weight	1.5 kg

Standard Equipment: Glasses for laser, Shoulder Belt, Storage Case

AVAILABLE VARIANTS		
4.0Ah	2.0Ah	"Z" Version
		SK312GD Z TOOL ONLY INSIDE ALUMINIUM CARRY CASE (DOES NOT INCLUDE BATTERY / CHARGER)

High brightness green laser for increased visibility at bright site

Large handle prevents the tool from falling.

Fine adjustment knob fine-adjusted from either side by turning fine-adjustment knob

Adjustment screw leg Horizontal line can be adjusted

allows to be charged from LXT batteries by using (optional) USB adapter ADP05 and power supply cable.



Adapter for USB ADP05
Power supply cable 199006-4

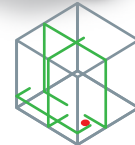

3-vertical line

CORDLESS

FIXING / FASTENING

DRILLING / IMPACT DRILLING

CONCRETE DRILLING / DEMOLITION

CUTTING [CONCRETE/ MASONRY/ METAL]

MULTI TOOL

GRINDING

SANDING / POLISHING

SAWING

ROUTERING / PLANING

CLEANING

HEAT GUN / LASERS

PNEUMATIC TOOLS

GARDEN TOOLS

GENERATORS

UR100D

Acc Pg. A210-212

12V MAX CXT Lithium-ion Cordless Grass Trimmer



12V max CXT Li-Ion Cordless Grass Trimmer

- Well balanced design with fully adjustable features to suit any operator
- Delivers 10,000 / 9,000 RPM for faster cutting
- Compact size is ideal for trimming and precise edging

Specifications:-



Cutting Width	Nylon Cutting Head: 260 mm
No Load Speed (RPM)	Nylon Cutting Head: 9,000
Spindle Size	M8 x 1.25 RH
Vibration Level	-
Dimensions (L x W x H)	835 - 1,185x267x210 - 315 mm
Max Run Time (min)	With BL1041B: 38
Net weight	2.3 kg

Standard Equipment: Safety Goggles, Shoulder Belt, Nylon Cutting Head, Nylon Cord, Hex Wrench

AVAILABLE VARIANTS		
4.0Ah	2.0Ah	"Z" VARIANT
UR100D WME INCLUDES 2 BATTERIES / 1 CHARGER		UR100D Z TOOL ONLY (DOES NOT INCLUDE BATTERY / CHARGER)

UM600D

Acc Pg. A209-210

12V MAX CXT Lithium-ion Cordless Grass Shear



Hedge trimmer blade (only with "Z" Variant)
Part No.198409-9

12V max CXT Li-Ion Cordless 16 cm Grass Shear

- Slimmer handle. More runtime. High performance
- Ergonomically designed handle with sure grip provides more control and comfort
- Up to 90 min of run time on a single battery BL1041B charge
- 2,500 SPM for efficient cutting
- 2 in 1: Both trimmer blade and shear blade can be attached

Specifications:-

Cutting Width	160 mm (6-5/16")
Depth Adjustment	15, 20, 25 mm
Strokes Per Minute (SPM)	2,500
Continuous Use (min.)	with BL1041B / BL1021B : 90 / 45min
Sound Pressure Level	75 dB(A)
Vibration Level	2.5 m/s ² or less
Dimensions (L x W x H)	329x177x131 mm
Net weight	1.5 kg

Standard Equipment: Grass shear blade, Grass Receiver, Blade Cover , Hedge Trimmer Blade (only with "z" variant)

AVAILABLE VARIANTS		
4.0Ah	2.0Ah	"Z" VARIANT
UM600D SM INCLUDES 1 BATTERIES / 1 CHARGER + GRASS SHEAR BLADE		UM600D ZX TOOL + GRASS SHEAR BLADE + HEDGE TRIMMER BLADE ONLY (DOES NOT INCLUDE BATTERY / CHARGER)

CORDLESS
FIXING / FASTENING
DRILLING / IMPACT DRILLING
CONCRETE DRILLING / DEMOLITION
CUTTING [CONCRETE/ MASONRY/ METAL]
MULTI TOOL
GRINDING
SANDING / POLISHING
SAWING
ROUTERING / PLANING
CLEANING
HEAT GUN / LASERS
PNEUMATIC TOOLS
GARDEN TOOLS
GENERATORS

UB100D Acc Pg. A213

12V MAX CXT Lithium-ion Cordless Blower



12Vmax LITHIUM-ION **NEW**

CXT

Compact cordless Blower Powered by Slide Li-ion Battery of Makita's 12Vmax Platform

- Variable speed control by trigger
- 3 air volume settings: Low, Medium, High
- Compact and lightweight design
- Ergonomic soft grip
- Vacuum function - can be used as a vacuum with a dust bag.

Specifications:-

Blowing Force	1.8 N
Max Air Volume	2.6 m³/min
Max Air Velocity	75 m/s
Max Sealed Suction	4.0 kPa
No Load Speed (RPM)	0 - 15,800
Run Time (min)	High / Mid / Low
Noise K Factor	3 dB(A)
Vibration Level	508 x 155 x 202 mm (with 4.0Ah)
Dimensions (L x W x H)	2.5 m/s² or less
Net weight	1.9kg (with 4.0Ah)

Standard Equipment: Rubber Nozzle

AVAILABLE VARIANTS		
4.0Ah	2.0Ah	"Z" VARIANT
		UB100D Z TOOL ONLY (DOES NOT INCLUDE BATTERY / CHARGER)

CL121D Acc Pg. A189-192

12V MAX CXT Lithium-ion Cordless Cleaner / Blower



12Vmax LITHIUM-ION

CXT

Compact cordless cleaner Powered by Slide Li-ion Battery of Makita's 12Vmax Platform

- Ideal for in-car cleaning
- Variable attachments suitable for in-car cleaning
- 2 functions in 1 machine convertible into a blower
- Up to 67 min. of continuous use from a single fully charged BL1041B
- Battery capacity warning lamp starts blinking when the remaining battery capacity gets low

Specifications:-

Capacity	Dust Bag : 500 mL / Paper Pack : 330 mL
Continuous Use (w/ BL1041B) (min.)	Max : 27 / High : 32 / Normal : 67
Max Air Flow	1.3 m³/min
Max Sealed Suction (water column)	4.4 kPa (450 mmH ₂ O)
Suction Power	Max : 30 W / High : 20 W / Normal : 5 W
Dimensions (L x W x H)	345x138x202 mm
Net weight	1.8 kg

Standard Equipment: Seat vacuum nozzle, Mat nozzle, Rubber nozzle, Soft brush, Blower attachment, Dust Bag, Shoulder Belt

AVAILABLE VARIANTS		
4.0Ah	2.0Ah	"Z" VARIANT
CL121D SM INCLUDES 1 BATTERY / 1 CHARGER AND TOOL BAG		CL121D Z TOOL ONLY (DOES NOT INCLUDE BATTERY / CHARGER ANDS TOOL BAG)

CL108FD Acc Pg. A188-192

12V MAX CXT Lithium-ion Cordless Cleaner



12Vmax LITHIUM-ION **NEW**

CXT

Quiet cleaning operation, Lightweight and High Power ideal for Commercial & Residential areas

one touch on / off switch
with 3 speed selection

LED joblight
With battery exhaust notification function (Flashes when the battery capacity becomes low) Convenient for cleaning in dark areas.

600 mL
Large dust capacity

Capsule Type
Quick dust disposal
No need to use paper bag

Angled suction port
Prevents extension pipe from wobbling in use

Continuous use
21min with BL1020B(2.0h)
42min with BL1040B (4.0Ah)

Specifications:-

Capacity	600 mL
Continuous Use (min.)	With BL1041B: Max/ High/ Normal: 20/ 24/ 50
Max Air Flow	1.3 m³/min
Max Sealed Suction (water column)	4.4 kPa
Suction Power	Max/ High/ Normal: 32/ 20/ 5W
Dimensions (L x W x H)	956x110x150 mm
Net weight	1.2 kg

Standard Equipment: Floor T-Nozzle28, Sash Nozzle, Sash Nozzle Holder, Pipe, Filter, Prefilter

AVAILABLE VARIANTS				
4.0Ah (Blue)	4.0Ah (White)	2.0Ah	"Z" VARIANT (Blue)	"Z" VARIANT (White)
CL108FD SM INCLUDES 1 BATTERY / 1 FAST CHARGER	CL108FD SMW INCLUDES 1 BATTERY / 1 FAST CHARGER	-	CL108FD Z TOOL ONLY (DOES NOT INCLUDE BATTERY / CHARGER)	CL108FD ZW TOOL ONLY (DOES NOT INCLUDE BATTERY / CHARGER)

CL106FD

Acc Pg. A188-192

12V MAX CXT Lithium-ion Cordless Cleaner



Quiet cleaning operation in Commercial & Residential areas

on/off trigger switch

located in the convenient position and can turn on quickly only when you want to use the machine



LED joblight

With battery exhaust notification function (Flashes when the battery capacity becomes low) Convenient for cleaning in dark areas.

600 mL

Large dust capacity

Capsule Type

Quick dust disposal No need to use paper bag



Angled suction port

Prevents extension pipe from wobbling in use

Continuous use

21min with BL1020B(2.0h)
42min with BL1040B (4.0Ah)



Specifications:-



Capacity	600 mL
Continuous Use (min.)	With BL1041B: 42
Max Air Flow	1.3 m ³ /min
Max Sealed Suction (water column)	3.1 kPa
Suction Power	19 W
Dimensions (L x W x H)	958x100x150mm
Net weight	1.1 kg

Standard Equipment: Floor T-Nozzle28, Sash Nozzle, Sash Nozzle Holder, Pipe, Filter, Prefilter

AVAILABLE VARIANTS

4.0Ah	2.0Ah	"Z" VARIANT
CL106FD WM INCLUDES 1 BATTERY / 1 CHARGER		CL106FD Z TOOL ONLY (DOES NOT INCLUDE BATTERY / CHARGER)

CLX203AX4

12V MAX CXT Lithium-ion Cordless (Percussion Driver Drill + Multi Tool) Combo Kit



COMBO KIT



HP331DZ
Percussion Driver Drill
(12VMAX Li-Ion),

TM30DZ
Multi-Tool
(12VMAX Li-Ion)

BL1021B
2pcs x 2.0Ah
Batteries
(12VMAX Li-Ion)

DC10WC
10.8V -12VMAX
CXT Li-ion Charger

13pcs
Oscillating Multi
Tool Accessories
in a plastic case
TMA007
Segment saw blade
TMA009
Plunge cut saw blade
Sanding pad
Abrasive Delta Paper
with mixed grit sizes
60, 80, 120, 180, 240,)



CORDLESS

FIXING / FASTENING

DRILLING / IMPACT DRILLING

CONCRETE DRILLING / DEMOLITION

CUTTING [CONCRETE / MASONRY / METAL]

MULTI TOOL

GRINDING

SANDING / POLISHING

SAWING

ROUTERING / PLANING

CLEANING

HEAT GUN / LASERS

PNEUMATIC TOOLS

GARDEN TOOLS

GENERATORS

- CORDLESS
- FIXING / FASTENING
- DRILLING / IMPACT DRILLING
- CONCRETE DRILLING / DEMOLITION
- CUTTING [CONCRETE/ MASONRY/ METAL]
- MULTI TOOL
- GRINDING
- SANDING / POLISHING
- SAWING
- ROUTERING / PLANING
- CLEANING
- HEAT GUN / LASERS
- PNEUMATIC TOOLS
- GARDEN TOOLS
- GENERATORS

Ultra-lightweight / Compact tools powered by 7.2V Lithium-ion Battery



DF012DSJ

Acc Pg. A024

7.2V LXT - Lithium-ion In-Line Cordless Driver Drill



Ultra-lightweight and compact tool

- Auto-stop clutch: tool shuts off when clutch disengages for extra fastening control; prevents overdriving the fastener
- 2-Speed design for high or low torque applications
- Comfortable grip design operates in straight or pistol grip positions
- Can be also used as a hand driver
- 21 Clutch settings and drill mode for added fastening control
- Lock lever prevents accidental startup

Specifications:-



Capacity	Steel: 5 mm / Wood: 6 mm
No Load Speed (RPM)	High: 650 / Low: 200
Max Fastening Torque	Hard / Soft: 5.6 / 3.6 N m
Dimensions (L x W x H)	Pistol Style: 218x44x142 mm
Dimensions (L x W)	Straight Style: 273x44 mm
Net weight	0.53 kg

Standard Equipment: Phillips Bit, 2pcs 7.2V 1.5Ah Batteries, Charger

TD022DSJ

Acc Pg. A024

7.2V LXT - Lithium-ion In-Line Cordless Impact Driver



Compact and lightweight design with precision control and high fastening torque

- Comfortable grip design operates in straight or pistol grip positions
- Can be also used as a hand driver
- Multi-function variable speed rotary switch allows operator to adjust driving speed and direction simultaneously for precise fastening applications
- Adjustable handle with enhanced hinge mechanism for operational versatility
- Electric brake for maximum productivity and increased operator safety
- Lock button prevents accidental startup

Specifications:-



Capacity	Machine Screw: M3 - M8 (1/8" - 5/16") Standard Bolt: M3 - M8 (1/8" - 5/16") High Tensile Bolt: M3 - M6 (1/8" - 1/4") Coarse thread (in length): 22 - 45 mm (7/8" - 1-3/4")
Hex Shank	6.35 mm (1/4")
No Load Speed (RPM)	0 - 2,450
Impacts Per Minute (IPM)	0 - 3,000
Max Fastening Torque	25 N m (220 in.lbs.)
Dimensions (L x W x H)	Straight Style: 282x42x52 mm Pistol Style: 227x42x142 mm
Net weight	0.56 kg

Standard Equipment: Holster, Bit set, 2pcs 7.2V 1.5Ah Batteries, Charger

Ultra-lightweight / Compact tools powered by 3.6V Lithium-ion Battery



CORDLESS

FIXING / FASTENING

DRILLING / IMPACT DRILLING

CONCRETE DRILLING / DEMOLITION

CUTTING [CONCRETE/ MASONRY/ METAL]

MULTI TOOL

GRINDING

SANDING / POLISHING

SAWING

ROUTERING / PLANING

CLEANING

HEAT GUN / LASERS

PNEUMATIC TOOLS

GARDEN TOOLS

GENERATORS

DF001DW

Acc Pg. A024

3.6V In-Built Lithium-ion Cordless Screwdriver



Ultra-lightweight and compact Screwdriver

- Convenient in a narrow space
- Operates in straight or pistol grip positions for comfortable operation
- Work amount is about 1.4 times as large as 6723DW
- Built-in LED job light with independent on/off switch
- On/off switch with forward and reverse modes
- Powered by a built-in rechargeable battery
- Includes Micro USB type AC adapter

Specifications:-



Fastening Capacities	Wood Screw: ø3.8 x 32 mm
No Load Speed (RPM)	220
Max Fastening Torque	Hard / Soft: 4.0 / 3.0 N m
Charging Time (hours)	3 - 5
Dimensions (L x W x H)	Straight style: 287x47x51mm Pistol style: 205x47x51mm
Net weight	0.36 kg

Includes 81pcs Bit Set

- Magnetic bit:** 1pc
- Philips Bits:** PH1 - 5pcs, PH0 - 5pcs
- Philips:** PH1 - 1pc, PH2 - 6pcs, PH3 - 3pcs
- Philips:** PH3 - 2Pcs,
Pozi: PZ0 - 1pc, PZ1 - 2pcs, PZ2 - 2pcs, PZ3 x 1pc
Hex: H2 - 2Pcs
- Hex:** H2.5 - 2Pcs, H3 - 2Pcs, H4 - 2Pcs, H5 - 2Pcs, H6 - 2Pcs
- Slotted:** 1.2x 6.5 - 2pcs
Square: SQ0 - 1pc, SQ1 - 2pcs, SQ2 - 2pcs, SQ2 - 1pc
- Magnetic Nut Setter:** 6pcs
10mm, 9mm, 8mm, 7mm, 6mm, 5mm
Philips 3pcs: PH3, PH2, PH1
Slotted 3pcs: 1.2X6.5, 0.8X5.5, 0.5X4.0
- Slotted:** 1.2x 6.5 - 2pcs
Square: SQ0 - 1pc, SQ1 - 2pcs, SQ2 - 2pcs, SQ2 - 1pc
- Slotted 10pcs:**
0.5x3 - 2pcs, 0.5x4 - 2pcs, 0.6x4.5 - 2pcs, 0.8x5.5 - 2pcs, 1.0x5.5 - 2pcs



In-built Battery with Controller

Part no: 620693-3

USB Cable

Part no: 661750-8

AC Adapter ADP07 with micro USB Port

Part no: 2pin - 198363-7

Part no: 3pin - 198369-5

Charging time: 3 to 5 hours



Standard Equipment: Bit set (81 pcs), Charger, USB Cable

- CORDLESS
- FIXING / FASTENING
- DRILLING / IMPACT DRILLING
- CONCRETE DRILLING / DEMOLITION
- CUTTING (CONCRETE/ MASONRY/ METAL)
- MULTI TOOL
- GRINDING
- SANDING / POLISHING
- SAWING
- ROUTERING / PLANING
- CLEANING
- HEAT GUN / LASERS
- PNEUMATIC TOOLS
- GARDEN TOOLS
- GENERATORS

Li-ion G-SERIES

The G-series range from Makita is a different lithium-ion battery platform to the Makita LXT range of professional cordless power tools and is powered exclusively by the G-Series battery and DC18WA charger.

Produced to a quality far exceeding that of DIY products, the G-series range offers a comprehensive range of tools at an attractive market price



G-SERIES BATTERIES

The G-Series battery is identifiable by the white top section and offers a 1.5Ah battery capacity in both **18V Li-ion** and **14.4V Li-ion** platforms. A 70-minute charge time is achieved with the G-Series DC18WA battery charger.

LIGHTER

1.5Ah Lithium-ion Series

70

MINUTES

With 1.5Ah Batteries



Charger: DC18WA
Battery Range: 14.4V - 18V
Adapted for: Li-ion G-SERIES
Charging Time: 60 Minutes

PLEASE NOTE THAT *G-SERIES BATTERIES ARE NOT COMPATIBLE WITH THE MAKITA LXT RANGE OF CORDLESS TOOLS OR CHARGERS

DF457D 13mm

Acc Pg. A024-060

18V G-Series Lithium-ion Cordless Driver Drill



Powered exclusively by the G-Series Li-ion battery.

- Compact and lightweight design.
- All metal gear construction ensures high transmission durability.
- Single sleeve keyless chuck enables easy bit installation/removal with one hand.
- Ergonomically designed rubberized soft grip provides more control and comfort.

Specifications:-



Capacity	Steel : 13mm (1/2") Wood : 36mm (1-7/16")
No load speed (rpm)	Hi : 0-1,400 / Lo : 0-400
Max. fastening torque	Hard / Soft : 42 / 24N m
Dimensions (L x W x H)	221x83x240mm (8-3/4"x3-1/4"x9-1/2")
Net weight	1.7kg (3.7lbs)

Standard Equipment: (+)(-) bit.

AVAILABLE VARIANTS

1.5Ah	"Z" VARIANT
DF457D WE INCLUDES 2 BATTERIES / 1 CHARGER / CARRYCASE	-

HP457D 13mm

Acc Pg. A024-060

18V G-Series Lithium-ion Cordless Percussion Driver Drill



Powered exclusively by the G-Series Li-ion battery.

- All metal gear construction ensures high transmission durability.
- Single sleeve keyless chuck enables easy bit installation/removal with one hand.
- Ergonomically designed rubberized soft grip provides more control and comfort.

Specifications:-



Capacity	Steel : 13mm (1/2") Wood : 36mm (1-7/16") Masonry : 13mm (1/2")
Impacts per minute (ipm)	Hi : 0-21,000 / Lo : 0-6,000
No load speed (rpm)	Hi : 0-1,400 / Lo : 0-400
Max. fastening torque	Hard / Soft : 42 / 24N m
Dimensions (L x W x H)	239x83x240mm (9-3/8"x3-1/4"x9-1/2")
Net weight	1.7kg (3.8lbs)

Standard Equipment: (+)(-) bit.

AVAILABLE VARIANTS

1.5Ah	"Z" VARIANT
HP457D WE INCLUDES 2 BATTERIES / 1 CHARGER / CARRYCASE	HP457D Z TOOL ONLY (BATTERY / CHARGER OR CARRY CASE NOT INCLUDED)

JV183D 10mm Acc Pg. A153

18V G-Series Lithium-ion Cordless Jig Saw

18V





Powered exclusively by the G-Series Li-ion battery.

- 3 orbital settings plus straight cutting for use in a wide range of materials
- Bevel cuts to 45° right or left and positive stop at 90° for solid cutting performance
- Heavy duty aluminum die-cast base increases durability and maximizes tool life
- Electric brake for maximum productivity and increased operator safety
- Dust cover prevents scattering of tips
- Through-the-body dust port provides optimal dust management with use of vacuum
- Dust nozzle can be attached for connection to Makita vacuum cleaner

Specifications:- 

Capacity	Wood: 65 mm Steel: 6 mm
Length of Stroke	18 mm
Strokes Per Minute (SPM)	0-2,900
Dimensions (L x W x H)	248x76x196 mm
Net weight	2 kg

Standard Equipment: Jig Saw Blade, Hex Wrench

AVAILABLE VARIANTS	
1.5Ah	"Z" VARIANT
	JV183D Z TOOL ONLY (DOES NOT INCLUDE BATTERY / CHARGER)



- CORDLESS
- FIXING / FASTENING
- DRILLING / IMPACT DRILLING
- CONCRETE DRILLING / DEMOLITION
- CUTTING [CONCRETE/ MASONRY/ METAL]
- MULTI TOOL
- GRINDING
- SANDING / POLISHING
- SAWING
- ROUTERING / PLANING
- CLEANING
- HEAT GUN / LASERS
- PNEUMATIC TOOLS
- GARDEN TOOLS
- GENERATORS

CL183D Acc Pg. A188-192

18V G-Series Lithium-ion Cordless Cleaner

18V





Low noise design ideal for quiet cleaning operation in job sites

- Compact and lightweight design.
- Quick clean-ups with strong suction power
- Increased storage capacity for longer time between waste disposal
- Bagless 2-stage cloth filtration system allows for easier cleaning
- Filter and pre-filter are washable in soapy water for repeated use
- Sash nozzle for cleaning corners and crevices of a car or furniture
- Angled suction port allows for easy floor cleaning without floor nozzle
- Ideal for shop, office, hospital, airport, plane, station, train, home use, etc

Specifications:-

Capacity	600 mL
Continuous Use (min.)	24
Max Air Flow	1.3 m³/min
Max Sealed Suction (water column)	2.6 kPa
Dimensions (L x W x H)	966x102x148 mm
	1.1 kg

Standard Equipment: Floor T-Nozzle28, Sash Nozzle, Sash Nozzle Holder, Pipe, Filter, Prefilter

AVAILABLE VARIANTS	
1.5Ah	"Z" VARIANT
CL183D W (IVORY COLOUR) INCLUDES 1 BATTERY / 1 CHARGER	CL183D Z (IVORY COLOUR) TOOL ONLY (DOES NOT INCLUDE BATTERY / CHARGER)

DK18113X1

18V G-Series Lithium-ion Cordless Combo Kit

Percussion driver drill + Jig saw

COMBO KIT



HP457DZ
18V G-Series Lithium-ion
Cordless Percussion Driver
Drill 13mm



2pcs of
BL1815G
18V 1.5Ah
G-series Battery



DC18WC
18V-14.4V G-series
Charger



JV183DZ
18V G-Series
Lithium-ion
Cordless Jig saw

CORDLESS
FIXING / FASTENING
DRILLING / IMPACT DRILLING
CONCRETE DRILLING / DEMOLITION
CUTTING (CONCRETE/ MASONRY/ METAL)
MULTI TOOL
GRINDING
SANDING / POLISHING
SAWING
ROUTERING / PLANING
CLEANING
HEAT GUN / LASERS
PNEUMATIC TOOLS
GARDEN TOOLS
GENERATORS

DF347D 10mm Acc Pg. A024-060

14.4V G-Series Lithium-ion Cordless Driver Drill



- Powered exclusively by the G-Series Li-ion battery.**
- Compact and lightweight design.
 - All metal gear construction ensures high transmission durability.
 - Single sleeve keyless chuck enables easy bit installation/removal with one hand.
 - Ergonomically designed rubberized soft grip provides more control and comfort.

Specifications:-

Capacity	Steel : 10mm (3/8") Wood : 25mm (1")
No load speed (rpm)	Hi : 0-1,400 / Lo : 0-400
Max. fastening torque	Hard / Soft : 30 / 15N m
Dimensions (L x W x H)	198x83x235mm (7-3/4" x3-1/4" x9-1/4")
Net weight	1.4kg (3.2lbs)

Standard Equipment: (+)(-) bit.

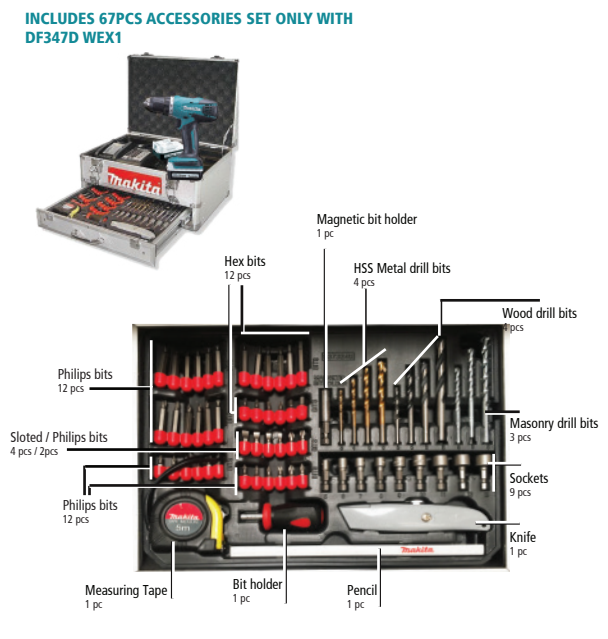

AVAILABLE VARIANTS		
1.5Ah	1.5Ah With Accessories Kit	"Z" VARIANT
DF347D WE INCLUDES 2 BATTERIES / 1 CHARGER / CARRYCASE	DF347D WEX1 INCLUDES 67PCS ACCESSORIES SET 2 BATTERIES / 1 CHARGER / CARRYCASE	-

HP347D 10mm Acc Pg. A024-060

18V G-Series Lithium-ion Cordless Percussion Driver Drill



- Powered exclusively by the G-Series Li-ion battery.**
- All metal gear construction ensures high transmission durability.
 - Single sleeve keyless chuck enables easy bit installation/removal with one hand.
 - Ergonomically designed rubberized soft grip provides more control and comfort.

Specifications:-

Capacity	Steel : 10mm (3/8") Wood : 25mm (1") Masonry : 10mm (3/8")
Impacts per minute (ipm)	Hi : 0-21,000 / Lo : 0-6,000
No load speed (rpm)	Hi : 0-1,400 / Lo : 0-400
Max. fastening torque	Hard / Soft : 30 / 15N m
Dimensions (L x W x H)	216x83x235mm (8-1/2" x3-1/4" x9-1/4")
Net weight	1.5kg (3.3lbs)

Standard Equipment: (+)(-) bit.

AVAILABLE VARIANTS	
1.5Ah	"Z" VARIANT
HP347D WE INCLUDES 2 BATTERIES / 1 CHARGER / CARRYCASE	-



COMFORT@WORK

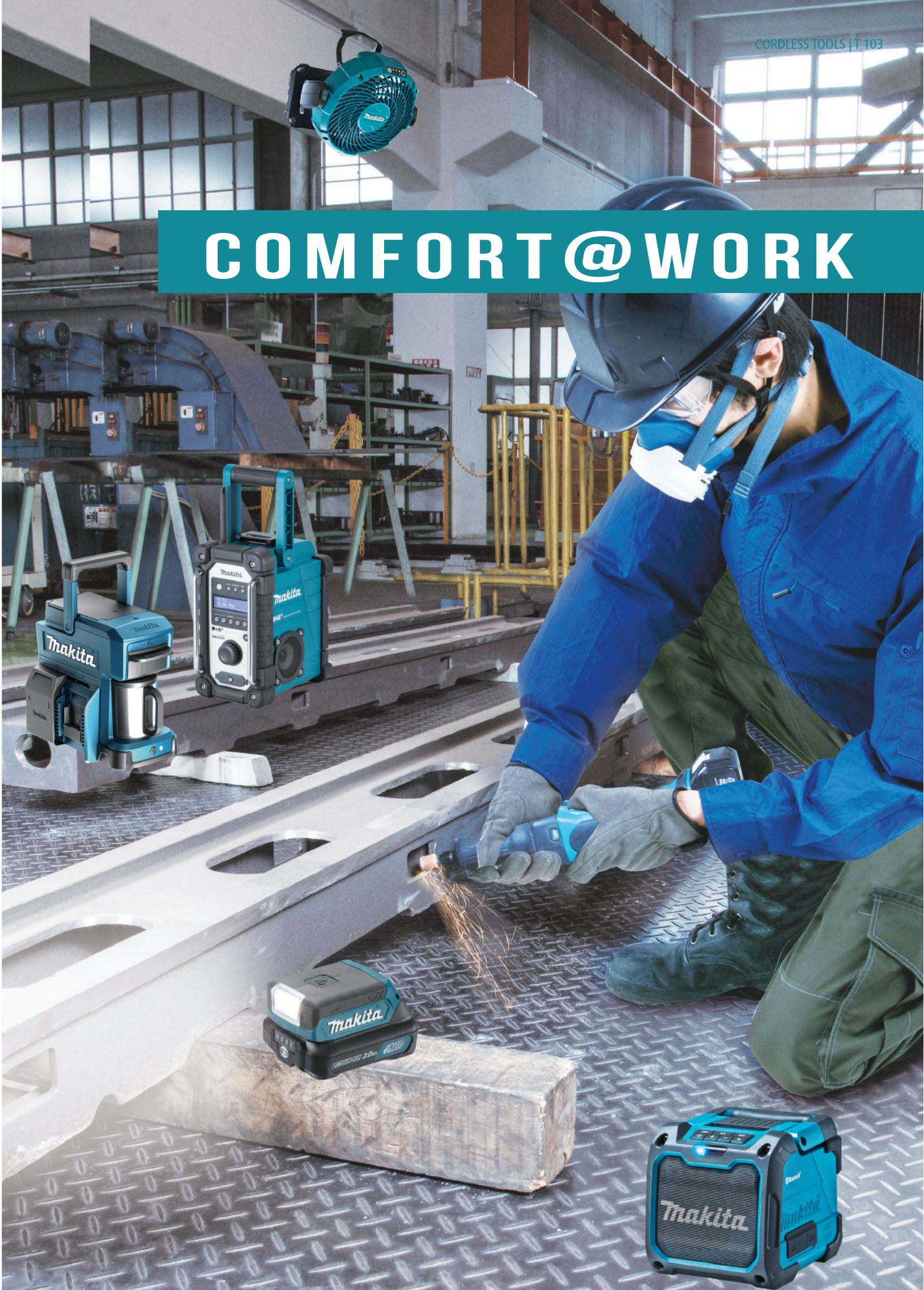

- CORDLESS
- FIXING / FASTENING
- DRILLING / IMPACT DRILLING
- CONCRETE DRILLING / DEMOLITION
- CUTTING [CONCRETE/ MASONRY/ METAL]
- MULTI TOOL
- GRINDING
- SANDING / POLISHING
- SAWING
- ROUTERING / PLANING
- CLEANING
- HEAT GUN / LASERS
- PNEUMATIC TOOLS
- GARDEN TOOLS
- GENERATORS

DFJ206 / DFJ207 / DFJ304 / DFJ405 / DFJ407

LXT / CXT - Lithium-ion Cordless Fan Jacket



DFJ206 DFJ207
For General Work



DFJ304
For Grinding Work



DFJ405 DFJ407
For Outdoor Work



Makita Cordless Fan jackets are works with LXT or CXT battery holders (Battery Holder will not come along with the Cordless fan jacket and will be available as an optional accessories)

- Equipped with two pieces of flat fan units for increased comfort
- Fall prevention loops for fan units
- The strength of battery pockets are improved with two snap buttons
- Stand-up collar jackets: Cool air flows into helmet through stable stand-up collar for increased comfort
- Mesh pockets are provided on the back for storing ice packs



Two Fan units to cool you down efficiently with more comfort

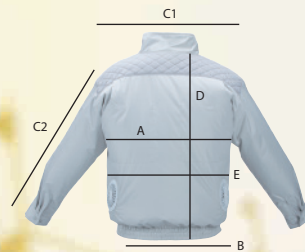

	size (in cm)	M	L	XL
A Chest width	A	121	126	131
B Waist	B	82	87	92
C1 Shoulder width	C1	54	56.5	59
C2 Sleeve length	C2	56	58	60
D Length	D	66	68	70
E Waist(MAX)	E	113	118	123

Specifications:-

Run Time (hrs)	with BL1860B Low / Medium / High: 40 / 26.5 / 18.5
Air Flow	Turbo / High / Medium / Low: 2.1 / 1.9 / 1.5 / 1.3 m ³ /min
Size	M / L / XL
Pockets	5
Net weight	Jackets without hood: 360 g / Jackets with hood: 380 g

AVAILABLE SIZES					
FOR	CLOTH TYPE	COLLAR	MEDIUM	LARGE	EXTRA LARGE
General work	Polyester	Standup Collar	DFJ206 MZ	DFJ206 LZ	DFJ206 XLZ
General work	Polyester	With hood	DFJ207 MZ	DFJ207 LZ	DFJ207 XLZ
Grinding work	Cotton	Standup Collar	DFJ304 MZ	DFJ304 LZ	DFJ304 XLZ
Outdoor work	Titanium + Polyester	Standup Collar	DFJ405 MZ	DFJ405 LZ	DFJ405 XLZ
Outdoor work	Titanium + Polyester	With hood	DFJ407 MZ	DFJ407 LZ	DFJ407 XLZ

(CORDLESS FAN JACKETS DOES NOT INCLUDE THE BATTERY HOLDER OR BATTERY / CHARGER AND CARRY CASE)

Accessories

Battery Holders



LXT battery holder compatible with All 18V and 14.4V LXT Li-ion batteries
PART NO: 198732-2



CXT battery holder compatible with All 10.8V/12V MAX CXT Li-ion batteries
PART NO: 198637-6



Adapter comes with USB output port which can charge mobiles and other chargeable devices (usb cable is not part of the adapter)

DFJ212 / DFJ213 / DFJ214 / DFV210

LXT / CXT - Lithium-ion Cordless Fan Jacket



Polyester
High-repellency fabric

Stand-up collar with stowaway hood
Casual type
■ DFJ212



Polyester
Stretchable fabric

Stand-up collar Working wear type
■ DFJ213



Polyester
Water repellency, antistatic fabric

Stand-up collar High-visibility type
■ DFJ214



Polyester
High-repellency fabric

Stand-up collar Vest type
■ DFV210



Makita Cordless Fan jackets are works with LXT or CXT battery holders (Battery Holder will not come along with the Cordless fan jacket and will be available as an optional accessories)

- Selectable 3 air flow modes (High/ Medium/ Low) + Turbo mode
- Fan units equipped with BL motor
- Appearance is highly visible, form is hardly expandable and improves the comfort to wear. (only for DFJ214)
- Form is hardly expandable and improves the comfort to wear (only for DFV210/ DFJ212/ DFJ213)
- Stand-up collar jackets: Cool air flows into helmet through stable stand-up collar for increased comfort

Stay cool in hot harsh job sites

Effective cooling air flow generated by two Fan units with BL motor



Insert supporting slider
■ DFJ212
■ DFV210



Velcro tabs for cuff adjustment
■ DFJ212



Drawcord on hem for adjustable fit
■ DFJ212
■ DFV210



Zip fastener with quick release function
■ DFJ213
■ DFJ214



Snap button and rubber shirting for hem adjustment
■ DFJ213
■ DFJ214



Antistatic
■ DFJ214



Retroreflective material
■ DFJ214

Specifications:-

Run Time (hrs)	33 / 24.5 / 13.5 hrs (with BL1860B) 13 / 9 / 5 hrs (with BL1041B)
Size	M / L / XL / 2XL
Pockets	5 (DFJ213) (DFJ214) / 4 (DFJ212) / 3 (DFV210)
Net weight	0.43kg (DFJ212) / 0.54kg (DFJ213) (DFJ214) / 0.38kg (DFV210)

TYPE	AVAILABLE SIZES			
	MEDIUM	LARGE	EXTRA LARGE	2 EXTRA LARGE
Casual	DFJ212Z M	DFJ212Z L	DFJ212Z XL	DFJ212Z 2XL
Working wear	DFJ213Z M	DFJ213Z L	DFJ213Z XL	DFJ213Z 2XL
high visibility	DFJ214Z M	DFJ214Z L	DFJ214Z XL	DFJ214Z 2XL
Vest	DFV210Z M	DFV210Z L	DFV210Z XL	DFV210Z 2XL

(CORDLESS FAN JACKETS DOES NOT INCLUDE THE BATTERY HOLDER OR BATTERY / CHARGER AND CARRY CASE)

Accessories
Battery Holders



LXT
LXT battery holder compatible with All 18V and 14.4V LXT Li-ion batteries
PART NO: 198732-2



CXT
CXT battery holder compatible with All 10.8V/12V MAX CXT Li-ion batteries
PART NO: 198637-6



Adapter comes with USB output port which can charge mobiles and other chargeable devices (usb cable is not part of the adapter)

CORDLESS

FIXING / FASTENING

DRILLING / IMPACT DRILLING

CONCRETE DRILLING / DEMOLITION

CUTTING [CONCRETE/ MASONRY/ METAL]

MULTI TOOL

GRINDING

SANDING / POLISHING

SAWING

ROUTERING / PLANING

CLEANING

HEAT GUN / LASERS

PNEUMATIC TOOLS

GARDEN TOOLS

GENERATORS

CORDLESS
FIXING / FASTENING
DRILLING / IMPACT DRILLING
CONCRETE DRILLING / DEMOLITION
CUTTING (CONCRETE/ MASONRY/ METAL)
MULTI TOOL
GRINDING
SANDING / POLISHING
SAWING
ROUTERING / PLANING
CLEANING
HEAT GUN / LASERS
PNEUMATIC TOOLS
GARDEN TOOLS
GENERATORS

DCV200

18V / 14.4V LXT - Lithium-ion Cordless Heated Vest





Stay warm in cold harsh job site environments.

- Up to 28 hours of heat with BL1850(B) battery
- 2 core heat zones (shoulders & back) provide optimum heat distribution.
- 3 heat settings for precise heating control
- On/Off heat controller with 3 LED indicators

Specifications:-

Run Time (hrs)	Low / Medium / High: 28 / 16 / 8 (with BL1850B)
Heat Zones	Total / Shoulders / Back: 2 / 1 / 1
Heat Settings	High / Medium / Low
Available Size	M / L / XL
Pockets	4
Net weight	0.66 kg (Jacket+fan)

Standard Equipment: Battery holder, pouch

AVAILABLE SIZES		
Medium	Large	Extra Large
DCV200 ZM (DOES NOT INCLUDE BATTERY / CHARGER OR CARRY CASE)	DCV200 ZL (DOES NOT INCLUDE BATTERY / CHARGER OR CARRY CASE)	DCV200 ZXL (DOES NOT INCLUDE BATTERY / CHARGER OR CARRY CASE)

18V LXT / 12V CXT - Lithium-ion Cordless Heated Blankets

Excellent usability and Warm

Power button
To turn on the blanket, press and hold the power button for a few seconds. To turn off, press and hold the power button again

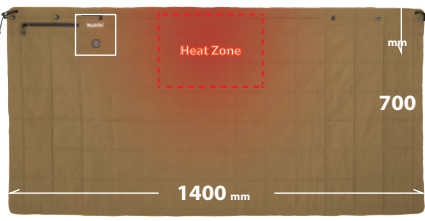

Temperature adjustment
There are three temperature settings (high, medium, low)

3-in-1 versatile blanket
By fastening the snap buttons and strap on the blanket, you can use the blanket for warming up your shoulders and waist.



Battery pocket
The battery holder (with battery cartridge) can be stored in the battery pocket.





Machine-washable and machine-dryable
Make sure to remove the battery holder from the blanket before washing and drying



DCB200B

18V / 14.4V LXT - Lithium-ion Cordless Heated Blanket

Excellent Usability and Warmth

- These blankets can be used as a lap blanket. Thanks to snap buttons and draw cord, they can also be used as a shawl and a warming overskirt.
- The shell material is easy-to-clean polyester while the lining is made of soft polyester faux fur
- Machine-washable and machine-dryable
- Battery pocket for secure storage of the battery
- 3 heat settings (high/ medium/ low) for desired warmth

Specifications:-



Material	Outer: 100% Polyester / Batting: 100% Polyester / Liner: 100% Polyester
Run Time (hrs)	w/ BL1860B Low / Med / High: 35 / 20 / 10
Heat Zones	Upper Center: 1
Heat Settings	High / Medium / Low
Available Size	High: 9.5 W / Med: 4.5 W / Low: 2.3 W
Pockets	700x1,400 mm
Net weight	0.58 kg

Standard Equipment: Battery holder , Battery Holder, Storage bag, 1.5m Extension cord.

AVAILABLE SIZES		
5.0Ah	3.0Ah	Z VARIANT
		DCB200B Z (DOES NOT INCLUDE BATTERY / CHARGER OR CARRY CASE)

CB100DB

12V MAX CXT - Lithium-ion Cordless Heated Blanket

Excellent Usability and Warmth

- These blankets can be used as a lap blanket. Thanks to snap buttons and draw cord, they can also be used as a shawl and a warming overskirt.
- The shell material is easy-to-clean polyester while the lining is made of soft polyester faux fur
- Machine-washable and machine-dryable
- Battery pocket for secure storage of the battery
- 3 heat settings (high/ medium/ low) for desired warmth

Specifications:-

Material	Outer: 100% Polyester / Batting: 100% Polyester / Liner: 100% Polyester
Run Time (hrs)	w/ BL1041B Low / Med / High: 14 / 7.5 / 4
Heat Zones	Upper Center: 1
Heat Settings	High / Medium / Low
Available Size	High: 9.5 W / Med: 4.5 W / Low: 2.3 W
Pockets	700x1,400 mm
Net weight	0.58 kg

Standard Equipment: Battery holder , Battery Holder, Storage bag, 1.5m Extension cord.

AVAILABLE SIZES		
5.0Ah	3.0Ah	"Z" VARIANT
		CB100DB Z (DOES NOT INCLUDE BATTERY / CHARGER OR CARRY CASE)

CF001G

40V MAX XGT - Lithium-ion Cordless Fan



Quiet running & Powerful wind with 40V MAX XGT battery

- 235 mm large fan produces strong enough air to create a comfortable work environment
- AC/DC dual power source: AC adapter or Makita XGT Li-Ion battery
- Automatically swings 45° L/R
- Up to 11 hours of continuous runtime on low speed with a 40Vmax 4.0Ah XGT battery
- 3 settings (High 190 m/min, Medium 150 m/min, Low 120 m/min)

Specifications:-

Continuous Use (min.) w/o oscillation	w/ BL4040 Low / Mid / High: 1,160 / 880 / 660
Continuous Use (min.) w/ oscillation	w/ BL4040 Low / Mid / High: 1,055 / 800 / 600
Max Air Velocity	High / Mid / Low: 190 / 150 / 120 m/min
Air Flow	High / Mid / Low: 8.2 / 6.5 / 5.2 m³/min
Fan Diameter	235 mm
Noise Level	48 dB(A) (w/ high speed)
Dimensions (L x W x H)	143x333x463 mm
Net weight	3.0 kg

Standard Equipment: AC adapter

AVAILABLE VARIANTS		
4.0Ah	"Z" VARIANT	
	CF001G Z TOOL ONLY (DOES NOT INCLUDE BATTERY / CHARGER OR CARRY CASE)	

CF101D

12V MAX CXT - Lithium-ion Cordless Fan



Compact Size Allows Installation Even in Small Spaces

- Automatically Swings 45° L/R
- Compact size allows installation even in small spaces
- 3-stage automatic timer with 1, 2, and 4 hour power-off selection
- Up to 21.2 hours of continuous runtime on low speed with a 18V 6.0Ah LXT battery (battery not included)
- 3 settings (High 180 m/s, Medium 150 m/s, Low 120 m/s) for optimal air velocity control

Specifications:-

Continuous use (approx.) (min.)	Low / Medium / High: 630 / 380 / 275 (with BL1041B)
	Low / Medium / High: 315 / 190 / 135 (with BL1021B)
Max air flow: m /min	High / Med / Low: 4.6 / 3.8 / 3.0 L/min
Dimensions (L x W x H)	185x260x284 mm
Net weight	1.3 kg (with BL1021B) - 1.7 kg (with BL1041B)

AVAILABLE VARIANTS		
4.0Ah	2.0Ah	"Z" VARIANT
		CF101D Z TOOL ONLY (DOES NOT INCLUDE BATTERY / CHARGER OR CARRY CASE)

DCF102

18V / 14.4V LXT - Lithium-ion Cordless Fan



Compact Size Allows Installation Even in Small Spaces

- Automatically Swings 45° L/R
- Compact size allows installation even in small spaces
- 3-stage automatic timer with 1, 2, and 4 hour power-off selection
- Up to 21.2 hours of continuous runtime on low speed with a 18V 6.0Ah LXT battery (battery not included)
- 3 settings (High 180 m/s, Medium 150 m/s, Low 120 m/s) for optimal air velocity control

Specifications:-

Continuous use (approx.) (min.)	Low / Medium / High: 1,270 / 705 / 575 (with BL1860B)
Max air flow: m /min	High / Med / Low: 4.6 / 3.8 / 3.0 L/min
Dimensions (L x W x H)	185x272x284 mm
Net weight	2 kg (with BL1860B)

AVAILABLE VARIANTS		
5.0Ah	3.0Ah	"Z" VARIANT
		DCF102 Z TOOL ONLY (DOES NOT INCLUDE BATTERY / CHARGER OR CARRY CASE)

CF100D

12V MAX CXT - Lithium-ion Cordless Fan



Compact Size Allows Installation Even in Small Spaces

- Up to 10.5 hours of continuous runtime on low speed with a 4.0Ah CXT battery
- 3 settings (High 180 m/s, Medium 150 m/s, Low 120 m/s) for optimal air velocity control
- 180 mm Large fan produces strong enough air to create a comfortable work environment under hot weather conditions
- Fan head angle can be adjusted from side to side and up and down

Specifications:-

Continuous use (approx.) (min.)	Low / Medium / High: 630 / 380 / 275 (with BL1041B)
	Low / Medium / High: 315 / 190 / 135 (with BL1021B)
Max air flow: m /min	High / Med / Low: 4.6 / 3.8 / 3.0 L/min
Dimensions (L x W x H)	148x260x252 mm
Net weight	1.2 kg (with BL1021B) - 1.4 kg (with BL1041B)

AVAILABLE VARIANTS		
4.0Ah	2.0Ah	"Z" VARIANT
		CF100D Z TOOL ONLY (DOES NOT INCLUDE BATTERY / CHARGER OR CARRY CASE)

CORDLESS

FIXING / FASTENING

DRILLING / IMPACT DRILLING

CONCRETE DRILLING / DEMOLITION

CUTTING [CONCRETE/ MASONRY/ METAL]

MULTI TOOL

GRINDING

SANDING / POLISHING

SAWING

ROUTERING / PLANING

CLEANING

HEAT GUN / LASERS

PNEUMATIC TOOLS

GARDEN TOOLS

GENERATORS

CORDLESS
FIXING / FASTENING
DRILLING / IMPACT DRILLING
CONCRETE DRILLING / DEMOLITION
CUTTING [CONCRETE/ MASONRY/ METAL]
MULTI TOOL
GRINDING
SANDING / POLISHING
SAWING
ROUTERING / PLANING
CLEANING
HEAT GUN / LASERS
PNEUMATIC TOOLS
GARDEN TOOLS
GENERATORS

DML814

18V LXT - Lithium-ion Cordless Area Worklight



3 brightness settings: 3,000 lumens on high mode

- Two lighting modes: Spot lighting / Area lighting
- Telescopic light mast enables lighting at a height up to 2.2m
- IP55 certified weather and dust resistance
- Highly stable tripod base, foldable into a compact size for simple storage and transport
- Shoulder belt attachable to the worklight or tool bag for comfortable carrying

Specifications:-

Run Time (hrs)	w/ BL1850(B) Low / Mid / High: 10 / 5.5 / 3
Illuminance (High / Mid / Low)	at 1m from the light source: 1,250 / 750 / 400 lx at 3m from the light source: 130 / 80 / 40 lx at 5m from the light source: 50 / 30 / 15 lx
Luminous Flux	High / Mid / Low: 3,000 / 1,700 / 900 lm
Dimensions (L x W x H)	Folding Position: 260x216x1,000 mm Operating Position (Max Height): 573x658x1,250-2,240 mm
Net weight	7.9 kg

AVAILABLE VARIANTS

5.0Ah	3.0Ah	"Z" VARIANT
		DML814 Z TOOL ONLY (DOES NOT INCLUDE BATTERY / CHARGER OR CARRY CASE)

The light head consists of 3 small light heads, and each of them can be pivoted independently for wide area lighting

LED color is daylight white, which is similar to the natural light (12 daylight white LEDs)

Two lighting modes
Spot lighting / Area lighting

Pivoting range of light head for Spot lighting

right and left **115°**

up and down **110°**

Pivoting range of 3 small light heads for area lighting

up and down **90°**

2,240 mm
The height of light head can be adjusted steplessly

1,250 mm

Easy installation and removal of battery

The battery port is located at the middle height of the worklight so that the user need not bend down to access the battery

Padlock hole for battery theft protection

*Padlock not included

Three hook holes for the shoulder belt

Two hook holes are located on the carrying handle beside the battery, and one on the end of a tripod leg

Tripod fixing hole

The tripod can be firmly secured to the ground with a screw or peg

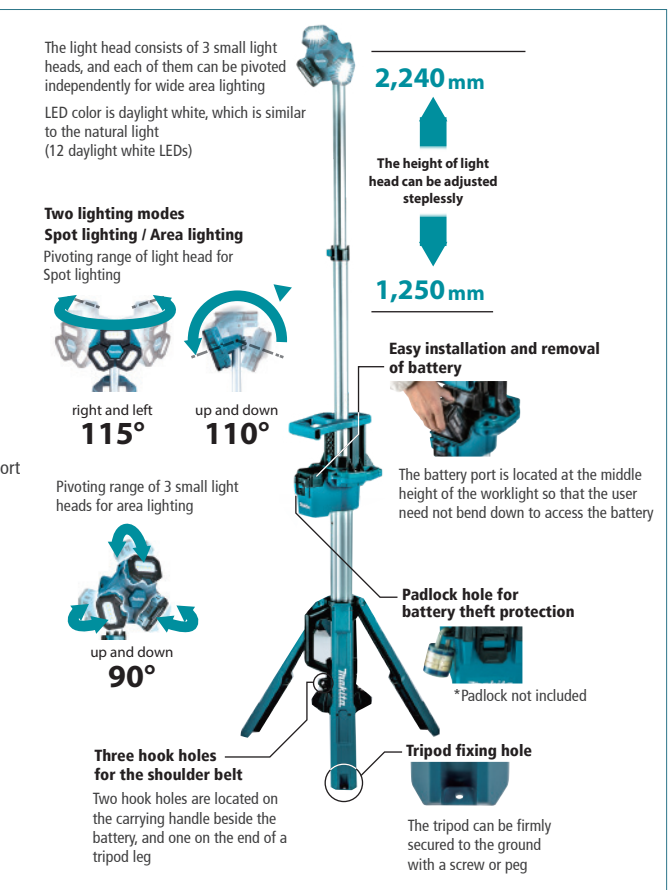

DML810

18V LXT - Lithium-ion Cordless + Corded Area Worklight



202 LED - Area Worklight (adapt upto 2 batteries)

- 3 brightness settings: 5,000 lumens on high mode
- Multi directional light (right, left & 360)

Up to 4 hours of continuous illumination on a full BL1860B (x2) charge at a constant illumination on high mode

202 super luminous daylight white LEDs

Chain up to 6 lights together

Runtime
4 / 8.5 / 18 min
with BL1860B9 x2

Specifications:-

Illuminance (High / Med / Low)	at 1m from the light source: 550 / 300 / 150 lx at 3m from the light source: 90 / 50 / 25 lx at 5m from the light source: 50 / 25 / 10 lx
Luminous Flux	High / Med / Low: 5,500 / 3,000 / 1,500 lm
Dimensions (L x W x H)	420x420x787 mm
Net weight	15.3 kg

AVAILABLE VARIANTS

5.0Ah	3.0Ah	"Z" VARIANT
		DML810 Z TOOL ONLY (DOES NOT INCLUDE BATTERY / CHARGER OR CARRY CASE)

DML809

18V LXT - Lithium-ion Cordless + Corded Area Worklight



96 LED - Area Worklight (adapt upto 2 batteries)

- 3-mode operation: delivers 10,000 lumens on high mode
- Up to 1.7 hours of continuous illumination with two 6.0Ah on high mode
- Dust and water-resistant construction (IP65 rated) for improved operation in harsh job site conditions
- L.E.D. lights effectively illuminate work area without the high heat of halogens

Specifications:-

Illuminance (High / Med / Low)	3,800 / 1,500 / 800 lx 380 / 150 / 80 lx 150 / 60 / 30 lx
Luminous Flux	10,000 / 4,000 / 2,000 lm
Dimensions (L x W x H)	w/ Handle in Retracted Position: 249x370x278 mm w/ Handle in Upright Position: 249x370x370 mm
Net weight	7.0 kg

AVAILABLE VARIANTS

5.0Ah	3.0Ah	"Z" VARIANT
		DML809 Z TOOL ONLY (DOES NOT INCLUDE BATTERY / CHARGER OR CARRY CASE)

Tripod (Optional) GM00002073

DML811 

18V LXT - Lithium-ion Cordless + Corded Area Worklight



30 LED - Area Worklight

- 3-mode operation: delivers 3,000 lumens on High mode
- Up to 13 hours of continuous illumination with a 6.0Ah on low mode
- Dust and water-resistant construction (IP65 rated) for improved operation in harsh job site conditions
- L.E.D. lights effectively illuminate work area without the high heat of halogens

Specifications:-

Illuminance (High / Med / Low)	1,800 / 800 / 350 lx 200 / 100 / 40 lx 85 / 40 / 17 lx
Luminous Flux	3,000 / 1,500 / 750 lm
Dimensions (L x W x H)	w/ Handle in Retracted Position: 249x302x271 mm w/ Handle in Upright Position: 249x302x361 mm
Net weight	4.8 kg

AVAILABLE VARIANTS

5.0Ah	3.0Ah	"Z" VARIANT
		DML811 Z TOOL ONLY (DOES NOT INCLUDE BATTERY / CHARGER OR CARRY CASE)

DML805 

18V LXT - Lithium-ion Cordless + Corded Area Worklight



20 LED - Area Worklight

- 2-Mode operation: delivers 750 lumens on High mode
- Up to 17 hours of continuous illumination with a 5.0Ah battery on Low mode
- Extreme Protection Technology (XPT) is engineered for improved dust and water resistance for operation in harsh conditions (only with DC power)
- L.E.D. lights effectively illuminate work area without the high heat of halogens

Specifications:-

Illuminance (High / Med / Low)	at 0.5m from the light source Hi: 1,150 lx, Lo: 750 lx at 1m from the light source Hi: 300 lx, Lo: 200 lx
Luminous Flux	Hi: 750 lm, Lo: 450 lm
Dimensions (L x W x H)	214x261x328mm
Net weight	2.7 kg

AVAILABLE VARIANTS

5.0Ah	3.0Ah	"Z" VARIANT
		DML805 Z TOOL ONLY (DOES NOT INCLUDE BATTERY / CHARGER OR CARRY CASE)

DML812

18V LXT - Lithium-ion Cordless Flashlight



Over 640m Beam Distance & Max 1,250 Lumens flashlight

- 4-Mode operation: spot | flood | spot+flood | strobe
- Compact and ergonomic design provides increased comfort on the job
- Extreme Protection Technology (XPT) is engineered for improved dust and water resistance for operation in harsh conditions (only with DC power)
- 90° pivoting head for user convenience

Specifications:-

Luminous Flux	Up to 1,250
Dimensions (L x W x H)	317x111x121 mm (12-1/2"x4-3/8"x4-3/4")
Net weight	1.7 kg (3.8 lbs.)

AVAILABLE VARIANTS

5.0Ah	3.0Ah	"Z" VARIANT
		DML812 Z TOOL ONLY (DOES NOT INCLUDE BATTERY / CHARGER OR CARRY CASE)

DML815

18V LXT - Lithium-ion Cordless Flashlight



High-luminance 4 x 0.5 W LED flashlight provides 160 lumens

- Multi directional light (right, left & 360)
- Up to 54 Hours of Illumination with 18V LXT 6.0Ah Battery
- 12 position pivoting flashlight head with positive stops from 0° - 170°
- LED provides a sharp, round spotlight

Specifications:-

Luminous Flux	160 lm
Illuminance	at 1m from the light source: 3,000 lx
Dimensions (L x W x H)	272x79x116 mm
Net weight	0.93 kg

AVAILABLE VARIANTS

5.0Ah	3.0Ah	"Z" VARIANT
		DML815 Z TOOL ONLY (DOES NOT INCLUDE BATTERY / CHARGER OR CARRY CASE)

CORDLESS

FIXING / FASTENING

DRILLING / IMPACT DRILLING

CONCRETE DRILLING / DEMOLITION

CUTTING [CONCRETE/ MASONRY/ METAL]

MULTI TOOL

GRINDING

SANDING / POLISHING

SAWING

ROUTERING / PLANING

CLEANING

HEAT GUN / LASERS

PNEUMATIC TOOLS

GARDEN TOOLS

GENERATORS

- CORDLESS
- FIXING / FASTENING
- DRILLING / IMPACT DRILLING
- CONCRETE DRILLING / DEMOLITION
- CUTTING [CONCRETE/ MASONRY/ METAL]
- MULTI TOOL
- GRINDING
- SANDING / POLISHING
- SAWING
- ROUTERING / PLANING
- CLEANING
- HEAT GUN / LASERS
- PNEUMATIC TOOLS
- GARDEN TOOLS
- GENERATORS

ML106

12V MAX CXT - Lithium-ion Cordless LED Flashlight



High-luminance single LED flashlight provides 190 lumens

- Zoom function adjusts illumination range
- 4.9 W high-luminance single LED
- Up to 32 hours of illumination with BL1860B

Specifications:-

Run Time (hrs)	Up to: 12
Luminous flux	190 lm
Illuminance	at 1m from the light source 170 - 4,500 lx
Dimensions (L x W x H)	271x66x93 mm
Net weight	0.78 kg

Standard Equipment: Strap Hook

AVAILABLE VARIANTS		
4.0Ah	2.0Ah	"Z" VARIANT
		ML106 Z TOOL ONLY (DOES NOT INCLUDE BATTERY / CHARGER OR CARRY CASE)

ML103

12V MAX CXT - Lithium-ion Cordless LED Flashlight



Compact size fits your hand perfectly









- Lightweight for reduced operator fatigue
- Ergonomic design easy to grip either from the top or the side
- Soft grip provides increased comfort
- 1.5W white single diffusion LED provides bright and wide illumination

Specifications:-

Run Time (hrs)	Up to: 28
Dimensions (L x W x H)	77x54x28 mm (without Battery)
Net weight	87x64x54 mm (with BL1021B)
	87x64x73 mm (with BL1041B)
	0.27 kg (with BL1021B) / 0.43 kg (with BL1041B)

AVAILABLE VARIANTS		
4.0Ah	2.0Ah	"Z" VARIANT
		ML103 Z TOOL ONLY (DOES NOT INCLUDE BATTERY / CHARGER OR CARRY CASE)

Cordless Flashlight and Worklight

	DML812	DML815	DML808	ML106	ML103	DML810	DML809	DML811	DML805
			 Zoom function	 Zoom function					
	18V LXT	18V LXT	18V LXT	12V MAX CXT	12V MAX CXT	18V LXT	18V LXT	18V LXT	18V LXT
Run time (hrs)	Up to : 8 with BL1850B	Up to : 45 with BL1850B	Up to : 26 with BL1850B	Up to : 12 with BL1041B	Up to : 28 with BL1041B	Up to : 15 with BL1850B x2	Up to : 7.5 with BL1850B x2	Up to : 11 with BL1850B	Up to : 17 Lo : with BL1850B
Illuminance at 1m from the light	71,000 / 51,000 / 520 lx	3,000 lx	170 - 4,500 lx	170 - 4,500 lx	50 lx	550 / 300 / 150 lx	3,800 / 1,500 / 800 lx	1,800 / 800 / 350 lx	300 - 200 lx
Luminous flux (lm=lumens)	Spot : 600 lm Spot/Flood : 1,250 lm Flood : 1,000 lm	160 lm	190 lm	190 lm	100 lm	High: 5,500 lm Med: 3,000 lm Low: 1,500 lm	High: 10,000 lm Med: 4,000 lm Low: 2,000 lm	High: 3,000 lm Med: 1,500 lm Low: 750 lm	Hi : 750 lm Lo : 450 lm
Net weight	1.7 kg	0.93 kg	1.09 kg	0.78 kg	0.43 kg	15.3 kg	7.0 kg	4.8 kg	2.7 kg

- CORDLESS
- FIXING / FASTENING
- DRILLING / IMPACT DRILLING
- CONCRETE DRILLING / DEMOLITION
- CUTTING [CONCRETE/ MASONRY/ METAL]
- MULTI TOOL
- GRINDING
- SANDING / POLISHING
- SAWING
- ROUTERING / PLANING
- CLEANING
- HEAT GUN / LASERS
- PNEUMATIC TOOLS
- GARDEN TOOLS
- GENERATORS

DMP180

18V LXT - Lithium-ion Cordless Inflator





NEW





Max pumping capacity
10 L/min

Max air pressure
830 kPa (121PSI)

Note: Recommended working cycle: Inflate for 5 minutes and rest the machine for 5 minutes

Valve Adapters

	Car / Motorcycle	Bicycle	Road bike	Ball	Beach ball / For Swim ring
Valve shape					
Adapter <small>(Standard equipment)</small>	American <small>does not come with MP100D</small>	British TE00000346	French TE00000334	For Balls TE00000335	For Swim rings/ Beach balls TE00000333
Maximum air pressure: kPa	(approx.) 250	(approx.) 300	(approx.) 700	(approx.) 90	50 and under
Discharge amount: L/ min <small>(at Target pressure)</small>	283	13	25	25	33
a single full battery charge: count	Car tires (215/60R16) 9	Bicycle tires (Size-26inch) 166	Road bike tires (700x23c) 92	Soccer balls (Size-5) 142	Beach balls (dia.30cm) 121

Specifications:- 

Max air Pressure	830 kPa (121 PSI) [8.3 bar]
Air Discharge Amount	200 kPa: 10 L/min
Hose Length	65 cm (25-1/2")
Dimensions (L x W x H)	270x76x175 mm
Net weight	1.8 kg

Standard Equipment: British Adapter, French Adapter, Ball Adapter, Swim Ring Adapter

AVAILABLE VARIANTS		
5.0Ah	3.0Ah	"Z" VARIANT
		DMP180 Z <small>(DOES NOT INCLUDE BATTERY / CHARGER OR CARRY CASE)</small>

MP100D

12V MAX CXT - Lithium-ion Cordless Cordless Inflator











Max pumping capacity
10 L/min

Max air pressure
830 kPa (121PSI)

Note: Recommended working cycle: Inflate for 5 minutes and rest the machine for 5 minutes

Valve Adapters

	Car / Motorcycle	Bicycle	Road bike	Ball	Beach ball / For Swim ring
Valve shape					
Adapter <small>(Standard equipment)</small>	American <small>does not come with MP100D</small>	British TE00000346	French TE00000334	For Balls TE00000335	For Swim rings/ Beach balls TE00000333
Maximum air pressure: kPa	(approx.) 250	(approx.) 300	(approx.) 700	100 and under	50 and under
Discharge amount: L/ min <small>(at Target pressure)</small>	10	9	4	11	11.5
a single full battery charge: count	Car tires (215/60R16) 2	Bicycle tires (Size-26inch) 46	Road bike tires (700x23c) 20	Soccer balls (Size-5) 63	Beach balls (dia.30cm) 54

Specifications:- 

Max air Pressure	830 kPa (121PSI)
Air Discharge Amount	200 kPa: 10 L/min
Hose Length	65 cm (25-1/2")
Dimensions (L x W x H)	w/ BL1021B: 235x74x173 mm w/ BL1041B: 255x74x173 mm
Net weight	1.3 kg

Standard Equipment: British Adapter, French Adapter, Ball Adapter, Swim Ring Adapter

AVAILABLE VARIANTS		
5.0Ah	3.0Ah	"Z" VARIANT
		MP100D Z <small>(DOES NOT INCLUDE BATTERY / CHARGER OR CARRY CASE)</small>

- CORDLESS
- FIXING / FASTENING
- DRILLING / IMPACT DRILLING
- CONCRETE DRILLING / DEMOLITION
- CUTTING [CONCRETE/ MASONRY/ METAL]
- MULTI TOOL
- GRINDING
- SANDING / POLISHING
- SAWING
- ROUTERING / PLANING
- CLEANING
- HEAT GUN / LASERS
- PNEUMATIC TOOLS
- GARDEN TOOLS
- GENERATORS

DCM501



LXT / CXT Lithium-ion Cordless Coffee Maker



LXT CXT

Powered by either 18V, 12V or AC Power

- Easy pouring water, Thanks to removable Water tank coffee machine can be kept without wetting
- Boil dry protection function automatically turns the coffee maker off if there is not enough water

Specifications:-

Water Tank Capacity	240 mL
Continuous rating: W	190W (12V MAX) / 300W (18V-LXT)
Brewing capacity (approx)	260mL with 12v max 4.0Ah li-ion battery 320mL 18v LXT - 3.0Ah li-ion battery 640mL 18v LXT - 6.0Ah li-ion battery
Brewing time of 1cup of coffee:	7mins (160mL) (12V MAX) / 5mins (160mL) (18V-LXT)
Dimensions (L x W x H)	225x186x217 mm
Net weight	1.4 kg

Standard Equipment: Mug, Measuring Spoon

AVAILABLE SIZES		"Z" VARIANT
		DCM501 Z (DOES NOT INCLUDE BATTERY / CHARGER OR CARRY CASE)



DMR203

LXT / CXT Lithium-ion Cordless Bluetooth Speaker



Powerful & Deep Stereo Sound with Bluetooth and AUX-IN jack

- True Wireless Stereo technology for Multi-speaker connection
- Group chain allows you to link up to 10 speakers for ultimate wireless sound
- 7 Selectable sound modes to suit the music genre.
- Highly durable housing design with an IP65 rating against dust and water
- 101mm woofer and 36mm tweeter deliver 10W* of high quality radio
- Powered by either 18V, 12V or AC Power
- Max. 30m, Optimum 10m

Specifications:-

Speaker Size	Woofer/Tweeter: Ø101.6 / Ø36 mm
Max Output	18V / 12Vmax / AC : 10 / 3.5 / 3.5 W
	Version: 5.0
	Profile: A2DP / SCMS-T / AVRCP
	Supported Codec: SBC
Bluetooth	Max Transmission Range (Optimum): 10 m (33 ft)
Dimensions (L x W x H)	Max Transmission Range (Possible): 30 m (100 ft)
Net weight	w/ Handle in Retracted Position: 217x206x199 mm 3.4 kg

AVAILABLE VARIANTS		"Z" VARIANT
5.0Ah	3.0Ah	DMR203 Z (DOES NOT INCLUDE BATTERY / CHARGER OR CARRY CASE)

DMR200

LXT / CXT Lithium-ion Cordless Bluetooth Speaker



Powerful & Deep Stereo Sound with Bluetooth and AUX-IN jack

- Highly durable housing design with an IP64 rating against dust and water
- 101mm woofer and 36mm tweeter deliver 10W* of high quality radio
- Powered by either 18V, 12V or AC Power
- Max. 30m, Optimum 10m

Specifications:-

Speaker Size	Woofer/Tweeter: Ø101.6 / Ø36 mm
Max Output	18V / 12Vmax / AC : 10 / 3.5 / 3.5 W
Bluetooth	Version: 4.0
	Profile: A2DP / SCMS-T / AVRCP
	Supported Codec: SBC
	Max Transmission Range (Optimum): 10 m (33 ft)
	Max Transmission Range (Possible): 30 m (100 ft)
Dimensions (L x W x H)	w/ Handle in Retracted Position: 211x203x199 mm
Net weight	3.4 kg

AVAILABLE VARIANTS		"Z" VARIANT
5.0Ah	3.0Ah	DMR200 Z (DOES NOT INCLUDE BATTERY / CHARGER OR CARRY CASE)

DMR107

LXT / CXT - Lithium-ion Cordless Jobsite Radio



Dual Power Sources: CXT/LXT Li-Ion batteries (12V max/7.2V,10.8V,14.4V/18V) or AC power adapter

- Delivers rich stereo sound from two powerful Ø76 mm side-firing speakers
- Maximum weather and water resistance suitable for jobsite or sports / recreational use
- Elastomer bumpers and metal pipes protect against rough handling
- AUX-IN jack for connecting to external audio source
- Illuminated control buttons and dial for improved visibility
- Swivel mount, soft bended antenna prevents breakage and/or loss

Specifications:-

Frequency Band	FM / AM: 87.5 - 108 MHz / 522 - 1,710 kHz
Speaker Size	Woofer: Ø76 mm x 2
Max Output	18 V: 3.5 W x 2 / 14.4 V: 2.2 W x 2 10.8 V: 1.2 W x 2 / 7.2 V: 0.5 W x 2
Dimensions (L x W x H)	257x163x431 mm
Net weight	4.1 kg

Standard Equipment: AC Adaptor

AVAILABLE VARIANTS	
	"Z" VARIANT
	DMR107 Z (DOES NOT INCLUDE LI-ION BATTERY / CHARGER OR CARRY CASE)

DMR110

LXT / CXT - Lithium-ion Cordless Jobsite Radio



Dual Power Sources: CXT/LXT Li-Ion batteries (12V max/7.2V,10.8V,14.4V/18V) or AC power adapter

- Delivers rich stereo sound from two powerful Ø76 mm side-firing speakers
- Maximum weather and water resistance suitable for jobsite or sports / recreational use
- Elastomer bumpers and metal pipes protect against rough handling
- AUX-IN jack for connecting to external audio source
- Illuminated control buttons and dial for improved visibility
- Swivel mount, soft bended antenna prevents breakage and/or loss

Specifications:-

Frequency Band	FM / DAB / DAB+: 87.5 - 108 MHz / 174.928 - 239.200 MHz / 174.928 - 239.200 MHz
Speaker Size	Woofer: Ø76 mm x 2
Max Output	18 V: 3.5 W x 2 / 14.4 V: 2.2 W x 2 10.8 V: 1.2 W x 2 / 7.2 V: 0.5 W x 2
Dimensions (L x W x H)	257x163x431 mm
Net weight	4.1 kg

Standard Equipment: AC Adaptor

AVAILABLE VARIANTS	
	"Z" VARIANT
	DMR110 Z (DOES NOT INCLUDE LI-ION BATTERY / CHARGER OR CARRY CASE)

BMR100

18V / 14.4V LXT - Lithium-ion Cordless Jobsite Radio



Dual Power Sources: 18V LXT Li-Ion batteries or AC power adapter

- Shower Proof withstands up to 5 minute exposure to rain.
- 2 Speaker Stereo System diameter 76mm (8 ohm) x 2
- Digital quartz display

Specifications:-

Practical max output	14.4V: 2Wx2, 18V: 3Wx2, 24V: 5Wx2
Frequency band	AM / FM : 522-1629kHz / 87.5-108 MHz
Dimensions (L x W x H)	261x167x433mm
Net weight	4.6kg

Standard Equipment: AC Adaptor

AVAILABLE VARIANTS	
	"Z" VARIANT
	BMR100 Z (DOES NOT INCLUDE LI-ION BATTERY / CHARGER OR CARRY CASE)

MR052

12V MAX CXT - Lithium-ion Cordless Jobsite Radio



Compact design radio for High portability

- Rubber rod antenna. (AM built in) No need to extend.
- AUX-IN JACK allows for connection to personal audio players.
- LCD digital display for better view even in dark area.
- Earphone Jack can connect with headphones
- Rotating rafter hook convenient to hang the radio on scaffolding pipe, etc

Specifications:-

Frequency Band	FM / AM: 87.5 - 108 MHz / 522 - 1,710 kHz
Continuous use (hours)	with BL1041B: 30 with BL1021B: 15
Dimensions (L x W x H)	169x73x74 mm
Net weight	0.72 kg

Standard Equipment: AC Adaptor

AVAILABLE VARIANTS	
	"Z" VARIANT
	MR052 Z (DOES NOT INCLUDE LI-ION BATTERY / CHARGER OR CARRY CASE)

- CORDLESS
- FIXING / FASTENING
- DRILLING / IMPACT DRILLING
- CONCRETE DRILLING / DEMOLITION
- CUTTING [CONCRETE / MASONRY / METAL]
- MULTI TOOL
- GRINDING
- SANDING / POLISHING
- SAWING
- ROUTERING / PLANING
- CLEANING
- HEAT GUN / LASERS
- PNEUMATIC TOOLS
- GARDEN TOOLS
- GENERATORS

CORDLESS
FIXING / FASTENING
DRILLING / IMPACT DRILLING
CONCRETE DRILLING / DEMOLITION
CUTTING (CONCRETE/ MASONRY/ METAL)
MULTI TOOL
GRINDING
SANDING / POLISHING
SAWING
ROUTERING / PLANING
CLEANING
HEAT GUN / LASERS
PNEUMATIC TOOLS
GARDEN TOOLS
GENERATORS

Compatible battery comparison

Model No.	Bluetooth	DAB+	DAB	(TWS) True Wireless Stereo Technology	USB	LXT		CXT					
						18V Li-ion	14.4V Li-ion	12Vmax Li-ion	10.8V Li-ion	7.2V Li-ion	18V G Li-ion	14.4V G Li-ion	18V9.6-V Ni-MH / Ni-Cd
DMR110		✓	✓			✓	✓	✓	✓	✓	✗	✗	✗
DMR107						✓	✓	✓	✓	✓	✗	✗	✗
BMR100						✓	✓	✗	✓	✓	✗	✗	✓
DMR203	✓			✓		✓	✓	✓	✗	✗	✗	✗	✗
DMR200	✓					✓	✓	✓	✗	✗	✗	✗	✗
MR052						✗	✗	✓	✗	✗	✗	✗	✗

ADP05

18V / 14.4V LXT - Lithium-ion Adapter for USB



Adapter Designed for job site durability, Compatible with IOS and Android devices

- These adapters can attached with Li-ion batteries and can charge USB compatible device such as Smartphone, Tablet, etc
- 2 USB output port: Enable to charge two devices at the same time
- Over discharge protection circuit
- Built-in strap hole attaches to a belt or holster

Specifications:-

Voltage	18V / 14.4V Li-ion (LXT)
USB port	2
Max output current A	One port: 2.1 / Two port 4.2
Dimensions	102x72x43mm
Net weight	0.11Kg

AVAILABLE VARIANTS

5.0Ah	3.0Ah	"Z" VARIANT
		ADP05 Z ADAPTER ONLY (DOES NOT INCLUDE BATTERY / CHARGER)

ADP06

12V MAX CXT - Lithium-ion Adapter for USB



Adapter Designed for job site durability, Compatible with IOS and Android devices

- These adapters can attached with Li-ion batteries and can charge USB compatible device such as Smartphone, Tablet, etc
- 1 USB output port: Enable to charge two devices at the same time
- Over discharge protection circuit
- Built-in strap hole attaches to a belt or holster

Specifications:-

Voltage	12V MAX Li-ion (CXT)
USB port	1
Max output current A	2.1
Dimensions	80x53x38mm
Net weight	0.07Kg

AVAILABLE VARIANTS

4.0Ah	2.0Ah	"Z" VARIANT
		ADP06 Z ADAPTER ONLY (DOES NOT INCLUDE BATTERY / CHARGER)

As a charger for smart phones

ADP05 Compatible with 18V LXT Li-ion batteries

ADP06 Compatible with 12V max CXT Li-ion batteries



Fixing / Fastening

Screwdrivers / Impact Wrenches



- CORDLESS
- FIXING / FASTENING
- DRILLING / IMPACT DRILLING
- CONCRETE DRILLING / DEMOLITION
- CUTTING [CONCRETE/ MASONRY/ METAL]
- MULTI TOOL
- GRINDING
- SANDING / POLISHING
- SAWING
- ROUTERING / PLANING
- CLEANING
- HEAT GUN / LASERS
- PNEUMATIC TOOLS
- GARDEN TOOLS
- GENERATORS

6821
Acc Pg. A024-031 **419**

Drywall Screwdriver

Powerful Makita motor for high speed performance.

- In-line design handle for maximum power thrust.
- Low noise level for quieter operation.
- Adjustable depth locator for consistent screw depth.
- Large variable speed trigger.

Specifications:-

Continuous rating input	570 W
Capacities	Drywall screw : 5 mm (3/16")
	Self drilling screw : 6 mm (1/4")
	Driving Shank (Hex) : 6 mm (1/4")
No load speed	0 – 4,000 rpm
Overall length	273 mm (10-3/4")
Net weight	1.3 kg (2.9 lbs)
Power supply cord	2.0 m (6.6 ft.)

Standard Equipment: Phillips Insert Bit (2pcs), Magnetic Bit Holder

FS2300
Acc Pg. A024-031 **419**

Drywall Screwdriver



Silent clutch for quiet operation

- Best possible tool body for screwdriving.
- Easy to bring pressure in line with center of driving bit axis.
- Bit holder and locator holder are provided.
- One touch locator, Durable belt clip.



Specifications:-

Continuous rating Input	570W
Capacity	Drywall screw : 5mm (3/16")
	Self drilling screw : 6mm (1/4")
Max Fastening Torque	Hard : 25Nm
Driving shank (Hex)	6.35mm (1/4")
No load speed (rpm)	0-2,500
Dimensions (L x W x H)	290 x 70 x 207mm (11-3/8" x 2-3/4" x 8-1/8")
Net weight	1.6kg (3.5lbs)
Power supply cord	2.5m (8.2ft)

Standard Equipment: Phillips Insert Bit (2pcs), Magnetic Bit Holder

FS4300
Acc Pg. A024-031 **419**

Drywall Screwdriver

Silent clutch for quiet operation

- Best possible tool body for screwdriving.
- Easy to bring pressure in line with center of driving bit axis.
- Bit holder and locator holder are provided.
- One touch locator, Durable belt clip.

Specifications:-

Continuous rating Input	570W
Capacity	Drywall screw : 5mm (3/16")
	Self drilling screw : 6mm (1/4")
Max Fastening Torque	Hard : 16Nm
Driving shank (Hex)	6.35mm (1/4")
No load speed (rpm)	0-4,000
Dimensions (L x W x H)	279 x 65 x 207mm (11" x 2-9/16" x 8-1/8")
Net weight	1.4kg (3.1lbs)
Power supply cord	2.5m (8.2ft)

Standard Equipment: Phillips Insert Bit (2pcs), Magnetic Bit Holder.

FS6300
Acc Pg. A024-031 **419**

Drywall Screwdriver



Silent clutch for quiet operation and high speed

- Best possible tool body for screwdriving.
- Easy to bring pressure in line with center of driving bit axis.
- Bit holder and locator holder are provided.
- One touch locator, Durable belt clip.

Specifications:-

Continuous rating Input	570W
Capacity	Drywall screw : 4mm (5/32")
Max Fastening Torque	Hard : 11N.m
Driving shank (Hex)	6.35mm (1/4")
No load speed (rpm)	0-6,000
Dimensions (L x W x H)	279 x 65 x 207mm (11" x 2-9/16" x 8-1/8")
Net weight	1.4kg (3.1lbs)
Power supply cord	2.5m (8.2ft)

Standard Equipment: Phillips Insert Bit (2pcs), Magnetic Bit Holder

6827

Acc Pg. A024-031 **419** 

Screwdriver (Torque control)



Features torque control system for a wide range of fastening jobs.

- Powerful 570W motor for superior fastening.
- All bearing construction and cast aluminum housing for tough jobs.
- Ergonomic soft grip for superior handling.
- Silent synchronised pin clutch for quiet operation.

Specifications:-



Continuous rating input	570W
Capacities	Machine screw : M8 (5/16")
	Hex screw : 6mm (1/4")
	Self drilling screw: 6mm (1/4")
	Driving shank (Hex): 6mm (1/4")
No load speed	0-2,500rpm
Overall length	304mm (12")
Net weight	1.8kg (4.0lbs)
Power supply cord	2.5m (8.2ft)

Standard Equipment: Phillips bit.

FS2500

Acc Pg. A024-031 **419** 

Screwdriver



Best possible tool body for screwdriving.

- Easy connect bit allows for quick bit change without using pliers.
- One touch locator, durable belt clip.
- A fully adjustable nose piece
- Can be used with self-drilling Tek screws
- Ideal for for roofing, façade, cladding and warehousing works

Specifications:-



Continuous rating Input	570W
Capacity	Drywall screw : 5mm (3/16")
	Self drilling screw : 6mm (1/4")
Max Fastening Torque	29 N.m
Driving shank (Hex)	6.35mm (1/4")
No load speed (rpm)	0-2,500
Dimensions	280 x 70 x 207mm
(L x W x H)	(11" x 2-3/4" x 8-1/8")
Net weight	1.5kg (3.4lbs)
Power supply cord	2.5m (8.2ft)

Standard Equipment: Magnetic Socket Bit

FS2700

Acc Pg. A024-031 **419** 

Screwdriver



6 Stage torque adjustment for a wide range of applications.

- Best possible tool body for screwdriving.
- Easy to bring pressure in line with center of driving bit axis.
- Bit holder is provided.
- LED job light convenient for operation in dark job sites.
- Durable belt clip.

Specifications:-



Continuous rating Input	570W
Capacity	Hex screw : 6mm (1/4")
	Drywall screw : 6mm (1/4")
	Self drilling screw : 6mm (1/4")
Max Fastening Torque	Hard : 8-32 N.m
Driving shank (Hex)	6.35mm (1/4")
No load speed (rpm)	0-2,500
Dimensions	301 x 70 x 207mm
(L x W x H)	(11-7/8" x 2-3/4" x 8-1/8")
Net weight	1.8kg (4.0lbs)
Power supply cord	2.5m (8.2ft)

6801B

Acc Pg. A024-031 **55** 

Screwdriver



Perfect for fastening Tek's or Hex screws.

- The ideal tool to set self-drilling screws.
- Lock ring to adjust stopper for self drilling screws or hex bolts.

Specifications:-



Continuous rating input	350W
Capacities	Self drilling screw : 6 mm (1/4")
Driving shank	(1/4") Hex
No load speed	2,000 rpm
Overall length	270 mm (10-5/8")
Net weight	2.1 kg (4.6 lbs)
Power supply cord	2.5 m (8.2 ft.)

Standard Equipment: Phillips Bit.

CORDLESS

FIXING / FASTENING

DRILLING / IMPACT DRILLING

CONCRETE DRILLING / DEMOLITION

CUTTING [CONCRETE/ MASONRY/ METAL]

MULTI TOOL

GRINDING

SANDING / POLISHING

SAWING

ROUTERING / PLANING

CLEANING

HEAT GUN / LASERS

PNEUMATIC TOOLS



GARDEN TOOLS

GENERATORS

- CORDLESS
- FIXING / FASTENING
- DRILLING / IMPACT DRILLING
- CONCRETE DRILLING / DEMOLITION
- CUTTING [CONCRETE/ MASONRY/ METAL]
- MULTI TOOL
- GRINDING
- SANDING / POLISHING
- SAWING
- ROUTERING / PLANING
- CLEANING
- HEAT GUN / LASERS
- PNEUMATIC TOOLS
- GARDEN TOOLS
- GENERATORS

6842
Acc Pg. 031 411

Auto Feed Screwdriver

Drives screws quickly with very little effort.

- Offers a more rigid aluminum casing with a stopper base.
- Anti tilt device to prevent the screws from swaying.
- More Reliable Casing Attachment.
- New Silent Clutch, ensures high operation efficiency with direct drive transmission in reverse rotation.

Specifications:-

Continuous rating Input	470W
Capacity	Drywall screw : 4x25 - 55mm (5/32"x1" - 2-3/16")
Bit size	Hex Shank : 6.35mm (1/4")
No load speed (rpm)	4,700
Dimensions (L x W x H)	400x75x243mm (15-3/4"x2-15/16"x9-9/16")
Net weight	2.0kg (4.4lbs)
Power supply cord	2.5m (8.2ft)

Standard Equipment: Phillips bit, Belt clip, Thumb screw

6806B 6mm (1/4")
Acc Pg. A042 64

Tapper



Adjustable torque settings for use on various types of materials.

- Equipped with forward/reverse switch.
- Light weight and portable size for easy handling.
- Equipped with double insulation for users safety.
- Maximum capacity 6 mm for steel.



Specifications:-

Continuous rating input	200 W
Capacity	Steel : 6 mm (1/4") Aluminium : 8 mm (5/16")
No load speed	Forward : 380 rpm Reverse : 750 rpm
Overall length	388 mm (15-1/4")
Net weight	2 kg (4.4 lbs.)
Power supply cord	2.5 m (8.2 ft.)

Standard Equipment: Chuck key.

TD0101
Acc Pg. A024 411

Impact Driver

Compact design for perfect handling.

- Externally accessible carbon brush.
- No harm to the wrist when a screw is seated.
- Enables to drive screws even without pre-drilling pilot holes.

Specifications:-

Continuous rating Input	230W
Capacity	Machine screw : M4 - M8 (5/32" - 5/16") Standard bolt : M5 - M14 (3/16" - 9/16") High tensile bolt : M5 - M10 (3/16" - 3/8") Coarse thread (in length): 22 - 90mm (7/8" - 3-1/2")
Driving shank (Hex)	6.35mm (1/4")
Impacts per minute (ipm)	0-3,200
No load speed (rpm)	0-3,600
Max. fastening torque	100N.m (885in.lbs)
Dimensions (L x W x H)	184 x 67 x 192mm
(L x W x H)	(7-1/4" x 2-5/8" x 7-9/16")
Net weight	0.99kg (2.2lbs)
Power supply cord	2.5m (8.2ft)

Standard Equipment: Phillips bit.

6904VH 12.7mm (1/2")
Acc Pg. A032-036 415

Impact Wrench





Versatile impact wrench for fastening nuts, bolts, and even lag screws.

- 2 speed selection with variable speed in both ranges.
- Light weight design for comfort and control.
- Rugged housing with rubber bumper for long tool life.
- Optional bit adapter for driving wood bits.



Specifications:-

Continuous rating Input	360W
Capacity	Standard bolt: M10 - M16 (3/8" - 5/8") High tensile bolt: M10 - M12 (3/8" - 1/2") Square drive : 12.7mm (1/2")
Impacts per minute	Hi : 0-3,000ipm / Lo : 0-2,500ipm
No load speed	Hi : 0-2,400rpm / Lo : 0-2,100rpm
Max. fastening torque	Hi : 196N.m (145ft.lbs) Lo : 147N.m (109ft.lbs)
Overall length	265mm (10-3/8")
Net weight	2.5kg (4.0lbs)

Standard Equipment: Sockets 3.

6953 12.7mm (1/2") Acc Pg. A032-036 **411** 

Impact Wrench

Compact body (overall length: 233mm) with palm-fitting soft grip for superior handling.

- Removable belt clip can be attached on both sides of the tool.
- Externally accessible carbon brushes for easy maintenance.



Specifications:- 

Continuous rating Input	280W
Capacity	Standard bolt: M10 - M16 (3/8" - 5/8") High tensile bolt: M8 - M12 (5/16" - 1/2") Square drive : 12.7mm (1/2")
Impacts per minute	0-3,000ipm
No load speed	0-3,000rpm
Max. fastening torque	150N.m (110ft.lbs)
Overall length	233mm (9-1/8")
Net weight	1.5kg (3.3lbs)
Power supply cord	2.5m (8.2ft)

Standard Equipment: Does not come with sockets.

TW0350 12.7mm (1/2") Acc Pg. A032-036 **411** 

Impact Wrench

Incredibly high torque of 350N.m (260ft.lbs).

- Rocker type switch for easy forward or reverse operation.
- Externally accessible carbon brushes for easy maintenance.

Specifications:- 

Continuous rating Input	400W
Capacity	Standard bolt : M12 - M22 (1/2" - 7/8") High tensile bolt : M12 - M16 (1/2" - 5/8") Square drive : 12.7mm (1/2")
Impacts per minute	2,000
No load speed	2,000
Max. fastening torque	350N.m (260ft.lbs)
Overall length	282mm (11-1/8")
Net weight	3.0kg (6.6lbs)
Power supply cord	2.5m (8.2ft)

Standard Equipment: Socket.

6906 19mm (3/4") Acc Pg. A032-036 **100** 

Impact Wrench



Powerful torque of 588N.m(441ft.lbs) for super-duty applications.

- Rocker type reversing switch for easy one handed forward or reverse operation.
- Slide handle adjusts 360degrees for operation convenience at any angle.
- Externally accessible carbon brushes for easy maintenance.

Specifications:- 

Continuous rating Input	115V / 220V 850W 230-240V 620W
Capacity	Standard bolt: M16 - M22 (5/8" - 7/8") High tensile bolt: M16 - M20 (5/8" - 3/4") Square drive : 19mm (3/4")
Impacts per minute	1,600ipm
No load speed	1,700rpm
Max. fastening torque	588N.m (441ft.lbs)
Overall length	327mm (12-7/8")
Net weight	5.6kg (12.3lbs)
Power supply cord	2.5m (8.2ft)

Standard Equipment: Grip Assembly, Socket.

TW1000 25.4mm (1") Acc Pg. A032-036 **153** 

Impact Wrench



Robust high torque Impact Wrench for heavy-duty application.

- Incredibly high torque 1,000N.m
- Rocker switch provides easy reversing.
- Rubber bumper for tool body protection.
- Features hanging hook for comfortable operation.

Specifications:- 

Continuous rating Input	1,200W
Capacity	Standard bolt: M24 - M30 (1 5/16" - 1 3/16") High tensile bolt: M22 - M24 (7/8" - 1 5/16") Square drive : 25.4mm (1")
No load speed	1,400rpm
Max. fastening torque	1,000N.m (738ft.lbs)
Overall length	382mm (15")
Net weight	8.6kg (19.9lbs)
Power supply cord	2.5m (8.2ft)

Standard Equipment: Socket 24-45, Grip

CORDLESS

FIXING / FASTENING

DRILLING / IMPACT DRILLING

CONCRETE DRILLING / DEMOLITION

CUTTING [CONCRETE / MASONRY / METAL]

MULTI TOOL

GRINDING

SANDING / POLISHING

SAWING

ROUTERING / PLANING

CLEANING

HEAT GUN / LASERS

PNEUMATIC TOOLS

GARDEN TOOLS

GENERATORS



Drilling / Impact Drilling

Driver Drill, Drill, Diamond Core Drill, Magnetic Drill, Drill Press, Impact Drill



DF0300 10mm Acc Pg. A032-060

Driver Drill

Excellent usability and compact

- Compact and lightweight design.
- 2 sleeve keyless Drill chuck allows for easy bit installation/ removal by one hand
- Mechanical 2-speed gearing
- 20 Torque settings
- Ergonomic handle with soft grip for driver-drill applications
- Variable speed control by trigger

Specifications:-

Continuous rating input	320W
Capacity	Steel / Wood: 10 / 28mm
Chuck Capacity	1.0 - 10 mm
No Load Speed (RPM)	High / Low: 0 - 1,500 / 0 - 450
Max Fastening Torque	Hard / Soft: 56.0 / 21.0 N m
Max lock torque	42.0 N m (370 in.lbs.)
Vibration Level	2.5 m/s ² or less
Sound Pressure Level	80 dB(A)
Sound Power Level	91 dB(A)
Dimensions (L x W x H)	220x67x206 mm
Net weight	1.2 kg
Power supply cord	2.5 m

6501 Acc Pg. A037-060 **70**

High Speed Drill



With depth gauge for uniform hole depth.

- With 4,500 rpm high speed rotation, ideal for fast drilling for small holes.
- Compact body weighs only 0.9kg for superior handling.

Specifications:-

Continuous rating input	230W
Capacity	Steel : 6.5 mm (1/4") Wood : 9 mm (11/32")
No load speed	4,500 rpm
Overall length	206 mm (8-1/8")
Net weight	0.9 kg (2.0 lbs)
Power supply cord	2.0 m (6.6 ft)

Standard Equipment: Chuck Key, Stopper Pole.

DP2010 6.5mm Acc Pg. A037-060 **419**

High Speed Drill



Compact body with elastomer grip to provide maximum comfort and control



- Designed For High Drilling Efficiency
- With 4,200 RPM high speed rotation, ideal for fast drilling of small holes
- In-line positive grip design maximises power thrust
- Forward / Reverse rotation change by lever
- 2 sleeve keyless Drill chuck allows for easy bit installation/ removal by one hand
- Trigger switch with variable speed control function by dial

Specifications:-

Continuous rating input	370W
Capacity	Steel: 6.5 mm Wood: 15 mm
No Load Speed (RPM)	0-4,200
Dimensions (L x W x H)	209x64x175 mm
Net weight	1.0 kg
Power supply cord	2.0 m

6010B 10mm (3/8") Acc Pg. A037-060 **64**

Drill

Very popular drill for one-hand operation.

- Features single speed switch.

Specifications:-

Continuous rating input	305W
Capacity	Steel : 10 mm (3/8") Wood : 15 mm (5/8")
No load speed	1,800 rpm
Overall length	233 mm (9-1/4")
Net weight	1.5 kg (3.5 lbs)
Power supply cord	2.5 m (8.2ft)

- CORDLESS
- FIXING / FASTENING
- DRILLING / IMPACT DRILLING
- CONCRETE DRILLING / DEMOLITION
- CUTTING [CONCRETE/ MASONRY/ METAL]
- MULTI TOOL
- GRINDING
- SANDING / POLISHING
- SAWING
- ROUTERING / PLANING
- CLEANING
- HEAT GUN / LASERS
- PNEUMATIC TOOLS
- GARDEN TOOLS
- GENERATORS

- CORDLESS
- FIXING / FASTENING
- DRILLING / IMPACT DRILLING
- CONCRETE DRILLING / DEMOLITION
- CUTTING [CONCRETE/ MASONRY/ METAL]
- MULTI TOOL
- GRINDING
- SANDING / POLISHING
- SAWING
- ROUTERING / PLANING
- CLEANING
- HEAT GUN / LASERS
- PNEUMATIC TOOLS
- GARDEN TOOLS
- GENERATORS

6010BVR 10mm (3/8")
 Acc Pg. A037-060 **64**

Drill

Very popular drill for one-hand operation.



- Features reversing switch and variable speed control trigger.

Specifications:-

Continuous rating input	305W
Capacity	Steel : 10 mm (3/8") Wood : 15 mm (5/8")
No load speed	0 – 1,800 rpm
Overall length	233 mm (9-1/4")
Net weight	1.5 kg (3.5 lbs)
Power supply cord	2.5 m (8.2ft)

6408 10mm (3/8")
 Acc Pg. A037-060 **419**

Drill

Variable speed (0-2,500rpm) for drilling in a variety of materials.

- In-line handle design for maximum power thrust.
- Low noise level for quieter operation.
- With keyless chuck.

Specifications:-

Continuous rating input	530 W
Capacity	Steel : 10 mm (3/8") Wood : 25 mm (1")
No load speed	0 – 2,500 rpm
Overall length	261 mm (10-1/4")
Net weight	1.5 kg (3.2 lbs)
Power supply cord	2.5 m (8.2 ft.)

6413 10mm (3/8")
 Acc Pg. A037-060 **64**

Drill



Compact and lightweight, yet with enough power.

- Ergonomically designed handle with rubberized grip provides more control and comfort.
- Chuck capacity: 1.5-10mm (1/16"-3/8").
- In-line design brings drilling pressure in line with center of drill bit axis.
- All ball bearing construction ensures high durability.

Specifications:-

Continuous rating Input	450W
Capacity	Steel : 10mm (3/8") Wood : 25mm (1")
No load speed (rpm)	0-3,400
Dimensions (L x W x H)	234 x 64 x 183mm (9-1/4" x 2-1/2" x 7-1/4")
Net weight	1.3kg (2.9lbs)
Power supply cord	2.0m (6.6ft)

DP4700 13mm (1/2")
 Acc Pg. A037-060 **64**

Drill





Heavy-duty performance drill for professionals.

- Variable speed (0-550 rpm) for versatility.
- Weighs only 2.2 kg for easy handling.
- Rugged industrial chuck.

Specifications:-

Continuous rating input	510 W
Capacity	Steel : 13 mm (1/2") Wood : 36 mm (1-3/8")
No load speed	0 – 550 rpm
Overall length	275 mm (10-7/8")
Net weight	2.2 kg (4.8 lbs)
Power supply cord	2.5 m (8.2 ft.)

Standard Equipment: Chuck Key, Grip

DS4011 13mm (1/2") Acc Pg. A037-060 **411** 



Drill





New aesthetic design.

- High performance.
- Full 360 degree rotatable D-handle with 24 positive stops for multi-position operation.

Specifications:-  

Continuous rating Input	750W
Capacity	Steel : 13mm Wood : 36mm
No load speed	600 rpm
Dimensions (L x W x H)	340 x 83 x 401 mm
Net weight	2.8kg
Power supply cord	2.5m

Standard Equipment: Chuck Key, Side Grip

DS5000 16mm (5/8") Acc Pg. A037-060 **411** 



Drill





New aesthetic design with 16mm drilling capacity.

- High performance.
- Full 360 degree rotatable D-handle with 24 positive stops for multi-position operation.

Specifications:-  

Continuous rating input	750W
Capacity	Steel: 16 mm Wood: 36 mm
No Load Speed (RPM)	600
Dimensions (L x W x H)	348x83x401 mm
Net weight	3.0 kg
Power supply cord	2.5 m

Standard Equipment: Chuck Key, Side Grip

6016 16mm (5/8") Acc Pg. A037-060 **51** 

Drill





Power and torque packed in rugged aluminum body for heavy duty applications.

- D-handle rotates 360 degrees for multi-position operation.
- Heavy-duty industrial chuck.

Specifications:-

Continuous rating Input	480W
Capacity	Steel : 16mm (5/8") Wood : 36mm (1-3/8")
No load speed	700rpm
Overall length	365mm (14-3/8")
Net weight	4.1kg (9.0lbs)
Power supply cord	2.5m (8.2ft)

Standard Equipment: Chuck Key, Grip, Depth Gauge

6305 13mm (1/2") Acc Pg. A037-060 **303** 

Drill





Rear handle with soft rubber grip, ergonomically designed for comfortable operation

- Warning lamp that indicates trouble with the cord, the switch or the motor
- Designed for installation on Type-43 drill stand.
- Double Insulated Construction

Specifications:- 

Continuous rating input	850W
Capacity	Steel: 13 mm (1/2") Wood: 30 mm (1-3/16")
No Load Speed (RPM)	1,450
Dimensions (L x W x H)	346x84x152 mm
Net weight	2.8 kg
Power supply cord	2.5 m

Standard Equipment: Chuck Key, Depth Gauge Assembly, Grip.

- CORDLESS
- FIXING / FASTENING
- DRILLING / IMPACT DRILLING
- CONCRETE DRILLING / DEMOLITION
- CUTTING [CONCRETE/ MASONRY/ METAL]
- MULTI TOOL
- GRINDING
- SANDING / POLISHING
- SAWING
- ROUTERING / PLANING
- CLEANING
- HEAT GUN / LASERS
- PNEUMATIC TOOLS
- GARDEN TOOLS
- GENERATORS

- CORDLESS
- FIXING / FASTENING
- DRILLING / IMPACT DRILLING
- CONCRETE DRILLING / DEMOLITION
- CUTTING [CONCRETE/ MASONRY/ METAL]
- MULTI TOOL
- GRINDING
- SANDING / POLISHING
- SAWING
- ROUTERING / PLANING
- CLEANING
- HEAT GUN / LASERS
- PNEUMATIC TOOLS
- GARDEN TOOLS
- GENERATORS

6301
106
Acc Pg. A037-060

Drill



Large side grip, D-handle and depth rod engineered for increased comfort in tough jobs.

Specifications:-

Continuous rating input	700 W
Capacity	Steel : 13 mm (1/2") Wood : 30 mm (1-1/8")
No load speed	1,300 rpm
Overall length	340 mm (13-3/8")
Net weight	3.1 kg (6.7 lbs)
Power supply cord	2.5 m (8.2 ft.)

Standard Equipment: Chuck Key, Depth Gauge Assembly, Grip.

DBM131
419
Acc Pg. A054

Diamond Core Drill



Lo Speed: 132mm (5-3/16")
Hi Speed : 70mm (2-3/4") Wet & Dry



Heavy duty wet diamond core drill with powerful motor for shock-free and accurate drilling into concrete and natural stone.

- Electronic torque limitation, speed control and constant speed even under load.

Specifications:-

Continuous rating Input	220V: 1,700W / 127V: 1,500W
Capacity	Concrete block (with diamond core bit): 132mm (5-3/16") Concrete (with diamond core bit): 70mm (2-3/4")
Tool holder	(Spindle) : M18
No load speed	Hi : 0-2,300rpm Lo : 0-1100rpm
Net weight	6.1kg (13.4lbs)

Recommended to be used with stand (P-40082)

DBM230
419
Acc Pg. A054

Diamond Core Drill



Lo speed : 230mm (9.05")
Hi speed : 60mm (2.36")



Heavy duty wet Diamond Core drill with a powerful 2,500W motor.

- With Overload protection; should the bit get jammed a clutch will slip and disengage the bit from the motor.
- LED light is provided to indicate overload
- Equipped with earth leakage breaker

Specifications:-

Continuous rating Input	2,500 W
Capacity	Concrete block (with diamond core bit) Low: 230mm Med: 100mm Hi: 60mm
Tool holder	(Spindle) : M18
No load speed	3rd : 1,700rpm 2nd : 1,040rpm 1st : 390rpm
Net weight	11.2kg (24.7lbs)

ALWAYS use the DBM230 with its Drill Stand Part No. P-54190.

DA3010
419
Acc Pg. A037-060

Angle Drill





Compact and light body weighs only 1.6kg (3.5 lbs)

- Only 66mm (2-5/8") in head height.
- With keyed chuck.

Specifications:-

Continuous rating input	450 W
Capacity	Steel : 10 mm (3/8") Wood : 25 mm (1")
No load speed	0 – 2,400 rpm
Overall length	270 mm (10-5/8")
Net weight	1.6 kg (3.5 lbs)
Power supply cord	2.5 m (8.2 ft.)

Standard Equipment: Chuck Key.

DA4000LR 13mm (1/2")

Acc Pg. A037-060

Angle Drill



Easy to turn over, new angle attachment for quick High (0-900rpm) / Low (0-400rpm) speed change.

- Enhanced gears in angled attachment for heavy duty industrial use.
- Ergonomic soft grip for superior handling.

Specifications:-



Continuous rating input	710W
Drilling capacities	Steel : 13mm (1/2")
	Wood (self-feed bit) Hi : 65mm (2-9/16")
	Wood (self-feed bit) Lo : 118mm (4-5/8")
	Wood (Hole saw) Hi : 114mm (4-1/2")
	Wood (Hole saw) Lo : 152mm (6")
No load speed	Hi : 0-900rpm
	Lo : 0-400rpm
Overall length	413mm (16-1/4")
Net weight	4.0kg (8.9lbs)
Power supply cord	2.5m (8.2ft)

Standard Equipment: Angle Attachment, Chuck Key, Hex Wrench, Grip.

TB131 13mm (1/2")

Acc Pg. A037-060 **51**

Drill Press



Compact Drill Press.

- 5 mode speed.
- Turn table (right or left : 45 degrees).

Specifications:-



Continuous rating input	250 W
HP	1/3
Drilling capacity	Steel : 13 mm (1/2")
	Wood : 24 mm (15/16")
	570, 890, 1300, 1900, 2670
	(50Hz) rpm 690, 1070, 1560,
	2280
No load speed	3,200 (60Hz) rpm
Net weight	20 kg (44.1 lbs)
Power supply cord	1.75 m (5.7 ft)

Standard Equipment: Chuck Key, Wrench.

HB500

Acc Pg. A056

Magnetic Drill



Heavy duty magnetic drill. (240V/5.3Ah)

- Magnetic base, drill stand, and drill machine all in one package system enables for easy setting.
- Powerful magnetic base supports stable and comfortable drilling work.
- Equipped with oil supply system for smooth drilling.

Specifications:-



Continuous rating Input	1,150W
Capacity	Steel : 50mm (2")
No load speed (rpm)	350/650
Magnetic clamping force	Minimum 2000PSI/907kgs
Net weight	17.9kg (39.5lbs)

Standard Equipment: Quick release arbor, Small oil cup assembly and clip, Carrying case, Safety guard, Polyester safety strap, Integral oil feed steady allen keys



CORDLESS

FIXING / FASTENING

DRILLING / IMPACT DRILLING

CONCRETE DRILLING / DEMOLITION

CUTTING [CONCRETE/ MASONRY/ METAL]

MULTI TOOL

GRINDING

SANDING / POLISHING

SAWING

ROUTERING / PLANING

CLEANING

HEAT GUN / LASERS

PNEUMATIC TOOLS

GARDEN TOOLS

GENERATORS

- CORDLESS
- FIXING / FASTENING
- DRILLING / IMPACT DRILLING
- CONCRETE DRILLING / DEMOLITION
- CUTTING [CONCRETE/ MASONRY/ METAL]
- MULTI TOOL
- GRINDING
- SANDING / POLISHING
- SAWING
- ROUTERING / PLANING
- CLEANING
- HEAT GUN / LASERS
- PNEUMATIC TOOLS
- GARDEN TOOLS
- GENERATORS



MIXING

UT1305 Acc Pg. A057 303



The best mixer for mixing paint, tile cement, structure plaster and filler at high speed.

- Heavy duty and high speed mixer
- Rear handle with soft rubber grip, ergonomically designed for comfortable operation
- Side handle provides maximum operator control during operation
- Dust cover effectively protects the motor and the transmission parts
- Indicator lamp (pilot lamp)

Specifications:-

Continuous rating input	850W
Blade Diameter	165 mm
No Load Speed (RPM)	1,300
Shank size of tool holder portion	M12
Dimensions (L x W x H)	942x87x152 mm
Net weight	2.6 kg
Power supply cord	2.5 m

Standard Equipment: Mixing Blade, Soft shaft

UT2204 Acc Pg. A057 303



850W heavy duty and high torque mixer.

- Rear handle with soft rubber grip, ergonomically designed for comfortable operation.
- Dust cover effectively protects the motor and the transmission parts.

Specifications:-

Continuous rating Input	850W
Mixing blade diameter	220mm (8-5/8")
No load speed	550rpm
Dimensions (L x W x H)	929mm x 89mm x 152mm (36-1/2" x 3-1/2" x 6")
Net weight	3.4kg (7.5lbs)
Power supply cord	2.5m (8.2ft)

Standard Equipment: Wrenches, Side Grip.

UT1400 140mm (5-1/2") Acc Pg. A057



This powerful 1300W, 1-speed mixing tool highly suitable for professional use up to 40-50 kg / litres.



- Due to its technical features this tool suits the needs of certain professionals for mixing paint, glue, plaster, etc.

Specifications:-

Continuous rating Input	1,050W (127V) / 1,300 (220V)
Mixing blade diameter	140mm (5-1/2")
No load speed	0-850rpm (127V) / 0-900rpm (220V)
Shank size	M14
Capacity	50L
Dimensions (L x W x H)	430 x 180 x 305mm
Net weight	5.2kg

HP0300 10mm Acc Pg. A037-060

Impact Drill

Excellent usability and compact

- Compact and lightweight design.
- 2 sleeve keyless Drill chuck allows for easy bit installation/ removal by one hand
- Mechanical 2-speed gearing
- 20 Torque settings
- Ergonomic handle with soft grip for driver-drill applications
- Variable speed control by trigger

Specifications:- 

Continuous rating input	320W
Capacity	Concrete / Steel / Wood: 8 / 10 / 28mm
Chuck Capacity	1.0 - 10 mm
No Load Speed (RPM)	High / Low: 0 - 1,500 / 0 - 450
Blows Per Minute (BPM)	High / Low: 0 - 22,500 / 0 - 6,750
Max Fastening Torque	Hard / Soft: 56.0 / 21.0 N m
Max lock torque	42.0 N m
Vibration Level	Impact Drilling into Concrete: 12.5 m/s ² Drilling into Metal: 2.5 m/s ² or less
Sound Pressure Level	82 dB(A)
Sound Power Level	93 dB(A)
Dimensions (L x W x H)	235x67x206 mm
Net weight	1.3 kg
Power supply cord	2.5 m

HP1230 12mm (15/32") Acc Pg. A037-060 **419**

Impact Drill



Aluminium gear housing provides high quality and toughness.

- Compact and lightweight design.
- 2 operation modes - hammering with rotation and rotation only.
- Ergonomically designed handle with rubberized grip provides more control and comfort.
- Easy-to-operate large trigger switch and lock-on button.

Specifications:- 

Continuous rating Input	400W
Capacity	Brick / Masonry : 12mm (15/32") Steel : 10mm (3/8") Wood : 15mm (9/16")
Impacts per minute (ipm)	0 - 31,900
No load speed (rpm)	0 - 2,900
Dimensions (L x W x H)	239 x 67 x 188mm (9-3/8" x 2-5/8" x 7-3/8")
Net weight	1.6kg (3.6lbs)
Power supply cord	2.0m (6.6ft)

Standard Equipment: Chuck Key, Depth Gauge, Side Handle.

NHP1300S 13mm (1/2") Acc Pg. A037-060 **415**

Impact Drill



A best seller worldwide due to amazing reliability.

- Upgraded, 13mm version of NHP1030.

Specifications:- 

Continuous rating input	430W
Capacity	Brick / Masonry : 13 mm (1/2") Steel : 13 mm (1/2") Wood : 18 mm (11/16")
Blows per minute	0 - 29,700 bpm
No load speed	0 - 2,700 rpm
Overall length	278 mm (10-7/8")
Net weight	1.7 kg (3.7lbs.)
Power supply cord	2 m (6.6 ft)

Standard Equipment: Chuck Key, Grip.

NHP1320S 13mm (1/2") Acc Pg. A037-060 **415**

Impact Drill



A best seller worldwide due to amazing reliability.

- Upgraded, 13mm version of NHP1030.

Specifications:- 

Continuous rating input	430W
Capacity	Brick / Masonry : 13 mm (1/2") Steel : 13 mm (1/2") Wood : 18 mm (11/16")
Blows per minute	29,700 bpm
No load speed	2,700 rpm
Overall length	278 mm (10-7/8")
Net weight	1.7 kg (3.7 lbs)
Power supply cord	2 m (6.6 ft)

Standard Equipment: Chuck Key, Grip.

- CORDLESS
- FIXING / FASTENING
- DRILLING / IMPACT DRILLING
- CONCRETE DRILLING / DEMOLITION
- CUTTING [CONCRETE/ MASONRY/ METAL]
- MULTI TOOL
- GRINDING
- SANDING / POLISHING
- SAWING
- ROUTERING / PLANING
- CLEANING
- HEAT GUN / LASERS
- PNEUMATIC TOOLS
- GARDEN TOOLS
- GENERATORS

- CORDLESS
- FIXING / FASTENING
- DRILLING / IMPACT DRILLING
- CONCRETE DRILLING / DEMOLITION
- CUTTING [CONCRETE/ MASONRY/ METAL]
- MULTI TOOL
- GRINDING
- SANDING / POLISHING
- SAWING
- ROUTERING / PLANING
- CLEANING
- HEAT GUN / LASERS
- PNEUMATIC TOOLS
- GARDEN TOOLS
- GENERATORS

HP1630K / HP1631K 16mm (5/8")

Acc Pg. A037-060 **85** 

Impact Drill

HIGH POWER 710W MOTOR



HP1631: Keyless Chuck
HP1630: Keyed Chuck



Sturdy Aluminum Gear Housing Cover

Dual-operation Mode:
Rotation only /
Hammering with rotation



Sturdy Cylinder-shaped Motor Housing

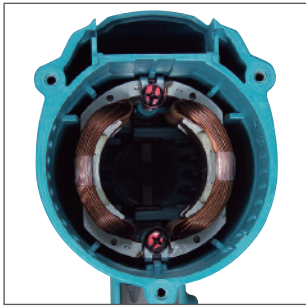

Continuous Rating Input:
710W
The highest in this class

Variable Speed Control
Switch with F/R Change
Lever



Rubberized Soft Grip
Provides more control and comfort.



Specifications:-

	HP1630K	HP1631K
Continuous rating Input	710W	710W
Capacity	Brick / Masonry: 16mm (5/8") Steel : 13mm (1/2") Wood: 30mm (1-3/16")	Brick / Masonry: 16mm (5/8") Steel : 13mm (1/2") Wood: 30mm (1-3/16")
Impacts per minute	0-48,000 ipm	0-48,000 ipm
No load speed	0-3,200 rpm	0-3,200 rpm
Dimensions (L x W x H)	296 x 75 x 204mm (11-5/8" x 2-15/16" x 8")	296 x 75 x 204mm (11-5/8" x 2-15/16" x 8")
Net weight	2.1kg (4.6lbs) : HP1630K 2.0kg (4.4lbs) : HP1631K	2.1kg (4.6lbs) : HP1630K 2.0kg (4.4lbs) : HP1631K
Power supply cord	2.0m (6.6ft)	2.0m (6.6ft)
Chucktype	Chuck type	Keyless Chuck



Standard Equipment: Side Grip, Chuck key for HP1630K.



HP1640 16mm (5/8")

Acc Pg. A037-060 **419**

Impact Drill



Dual purpose for "Rotation only" and "Rotation with hammering".

- New reversing system allows extended service life of carbon brush.
- No power reduction even in reverse rotation.
- In-line positive grip design maximizes power thrust.
- Large trigger switch for easy operation.
- Include 18pcs drill set in metal box
- Carrycase designed with storage compartment

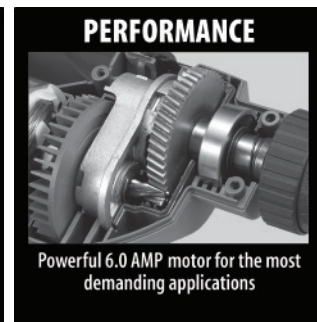
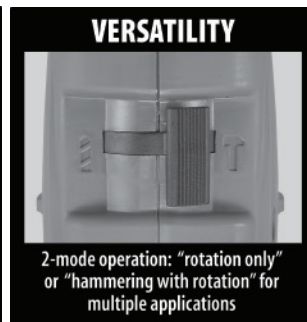
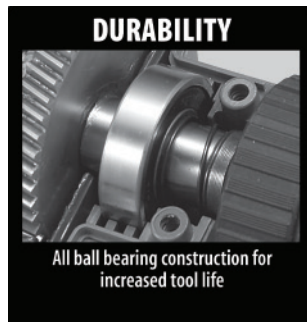

Specifications:-	HP1640K	HP1640KX2	HP1640KX3
Continuous rating Input	680W	680W	680W
Capacity	Brick / Masonry: 16mm (5/8") Steel: 13mm (1/2") Wood: 30mm (1-3/16")	Brick / Masonry: 16mm (5/8") Steel: 13mm (1/2") Wood: 30mm (1-3/16")	Brick / Masonry: 16mm (5/8") Steel: 13mm (1/2") Wood: 30mm (1-3/16")
Impacts per minute	0-44,800 ipm	0-44,800 ipm	0-44,800 ipm
No load speed	0-2,800 rpm	0-2,800 rpm	0-2,800 rpm
Dimensions (L x W x H)	303 x 72 x 222mm	303 x 72 x 222mm	303 x 72 x 222mm
Net weight	2.0kg (4.4lbs)	2.0kg (4.4lbs)	2.0kg (4.4lbs)
Power supply cord	2.0m (6.6ft)	2.0m (6.6ft)	2.0m (6.6ft)
Accessories Set	-	18Pcs Drill Set With Special Carry Case	74pcs Driver Set With Regular Carry Case



(Only Tool)



18pcs Drill set



74pcs driver drill set

Standard Equipment: Side Grip, Depth Gauge, Chuck Key



CORDLESS

FIXING / FASTENING

DRILLING / IMPACT DRILLING

CONCRETE DRILLING / DEMOLITION

CUTTING [CONCRETE/ MASONRY/ METAL]

MULTI TOOL

GRINDING

SANDING / POLISHING

SAWING

ROUTERING / PLANING

CLEANING

HEAT GUN / LASERS

PNEUMATIC TOOLS

GARDEN TOOLS

GENERATORS

- CORDLESS
- FIXING / FASTENING
- DRILLING / IMPACT DRILLING
- CONCRETE DRILLING / DEMOLITION
- CUTTING (CONCRETE/ MASONRY/ METAL)
- MULTI TOOL
- GRINDING
- SANDING / POLISHING
- SAWING
- ROUTERING / PLANING
- CLEANING
- HEAT GUN / LASERS
- PNEUMATIC TOOLS
- GARDEN TOOLS
- GENERATORS

8416
55
Acc Pg. A037-060

Impact Drill



Tough aluminum construction with 2 operation modes : "Rotation with hammering" and "Rotation only".

- Large side grip swivels 360degrees.
- Weighs only 2.7kg(6.0lbs).

Specifications:-

Continuous rating Input	570W
Capacity	Brick / Masonry: 16mm (5/8")
	Steel: 13mm (1/2")
	Wood: 30 mm (1-3/16")
Blows per minute	21,000bpm
No load speed	1,400rpm
Overall length	351mm (13-3/4")
Net weight	2.7kg (6.0lbs)
Power supply cord	2.5m (8.2ft)

Standard Equipment: Chuck Key, Grip Assembly, Depth Rod.

8419B
51
Acc Pg. A037-060

2-Speed Impact Drill



Industrial metal gear housing for durability and long tool life.

- Two-speeds for performance to match the task.

Specifications:-

Continuous rating Input	650 W
Capacity	Brick / Masonry: 19 mm (3/4")
	Steel: 13 mm (1/2")
	Wood: 30 mm (1-3/16")
No load speed	Hi : 1,300 rpm
	Lo : 1,000 rpm
Blows per minute	Hi : 14,300
	Lo : 11,000
Overall length	370 mm (14-1/2")
Net weight	3 kg (6.6 lbs.)
Power supply cord	2.5 m (8.2 ft.)

Standard Equipment: Chuck Key, Grip Assembly, Depth Rod.

8419B2
55
Acc Pg. A037-060

2-Speed Impact Drill



Industrial metal gear housing for durability and long tool life.

- Powerful 600W motor for Heavy-duty applications.

Specifications:-

Continuous rating Input	600 W
Capacity	Brick / Masonry: 19 mm (3/4")
	Steel: 13 mm (1/2")
	Wood: 30 mm (1-3/16")
No load speed	Hi : 2,300 rpm
	Lo : 900 rpm
Blows per minute	Hi : 46,000
	Lo : 18,000
Overall length	350 mm (13-3/4")
Net weight	3 kg (6.6 lbs.)
Power supply cord	2.5 m (8.2 ft.)

Standard Equipment: Chuck Key, Grip Assembly, Depth Rod.

8420V
106
Acc Pg. A037-060

Impact Drill



A powerful tool with a convenient variable speed feature.

- A flick of the switch for your choice of either hammering+rotation or rotation only.
- A powerful tool with a convenient, variable speed feature.
- Tough aluminium-clad body for heavy duty applications.

Specifications:-

Continuous rating input	660W
Capacity	Brick / Masonry: 20 mm (3/4")
	Steel: 13 mm (1/2")
	Wood: 30 mm (1-3/16")
Blows per minute	0 – 21,000 bpm
No load speed	0 – 1,400 rpm
Overall length	368 mm (14-1/2")
Net weight	3 kg (6.6 lbs)
Power supply cord	2.5 m (8.2 ft)

Standard Equipment: Chuck Key, Grip Assembly, Depth Rod.

HP2000 20mm (3/4") Acc Pg. A037-060 **106** 

2-Speed Impact Drill



Industrial metal gear housing for long lasting durability.

- Fast and steady drilling with powerful 800W motor.
- Two gear ranges for high or low torque variable speed in both ranges for pinpointing hole positioning.

Specifications:- 

Continuous rating Input	800 W
Capacity	Brick / Masonry: 20 mm (3/4") Steel: 13 mm (1/2") Wood: 40 mm (1-9/16")
No load speed	Hi: 0 – 2,300 rpm Lo: 0 – 900 rpm
Blows per minute	Hi: 0 – 46,000 Lo: 0 – 18,000
Overall length	350 mm (13-3/4")
Net weight	3 kg (6.6 lbs.)
Power supply cord	2.5 m (8.2 ft.)

Standard Equipment: Chuck Key, Grip Assembly, Depth Rod.

HP2010N 20mm (3/4") Acc Pg. A037-060 **106** 

2-Speed Impact Drill



Industrial metal gear housing for long lasting durability.

- Two speed gear change for ideal speed and power.
- Variable speed switch for easy starting of holes.
- Adjustable side handle for greater control.
- With reversible feature.

Specifications:- 

Continuous rating Input	750 W
Capacity	Brick / Masonry: 20 mm (3/4") Steel: 13 mm (1/2") Wood: 40 mm (1-9/16")
Blows per minute	Hi: 0 – 46,000 Lo: 0 – 18,000
No load speed	Hi: 0 – 2,300 rpm Lo: 0 – 900 rpm
Overall length	350 mm (13-3/4")
Net weight	2.9 kg (6.4 lbs.)
Power supply cord	2.5 m (8.2 ft.)

Standard Equipment: Chuck Key, Grip Assembly, Depth Rod.

HP2050 20mm (3/4") Acc Pg. A037-060 **419** 

2-Speed Impact Drill





Slender and compact body with durable metal gear housing.

- Extra-low vibration level for reduced operator fatigue.
- Dual purpose for "Rotation Only" and "Rotation with hammering".
- Built-in torque limiter stops bit rotation when hitting reinforcements.
- Industrial strength keyed chuck.
- Features a built-in LED job light.



Specifications:- 

Continuous rating Input	720W
Capacity	Brick / Masonry : 20mm (3/4") Steel Hi : 8mm (5/16") Steel Lo : 13mm (1/2") Wood Hi : 25mm (1") Wood Lo : 40mm (1-9/16")
Impacts per minute (ipm)	Hi : 0-58,000 Lo : 0-24,000
No load speed (rpm)	Hi : 0-2,900 Lo : 0-1,200
Overall length	362mm (14-1/4")
Net weight	2.5kg (5.6lbs)
Power supply cord	2.5m (8.2ft)

Standard Equipment: Chuck Key, Grip Assembly, Depth Rod.

HP2070 20mm (3/4") Acc Pg. A037-060 **419** 

2-Speed Impact Drill

High power in slender and compact body with durable metal gear housing (with keyless drill chuck).

- Dual purpose for "Rotation Only" and "Rotation with hammering".
- Built-in torque limiter stops bit rotation when hitting reinforcements.
- New reversing system allows: *Extended service life of carbon brush, *No power reduction even in reverse rotation

Specifications:- 

Continuous rating Input	1,010W
Capacity	Brick / Masonry : 20mm (3/4") Steel Hi : 8mm (5/16") Steel Lo : 16mm (5/8") Wood Hi : 25mm (1") Wood Lo : 40mm (1-9/16")
Impacts per minute (ipm)	Hi : 0-58,000 Lo : 0-24,000
No load speed (rpm)	Hi : 0-2,900 Lo : 0-1,200
Overall length	362mm (14-1/4")
Net weight	2.5kg (5.6lbs)
Power supply cord	2.5m (8.2ft)

Standard Equipment: Side Grip, Depth Rod..

- CORDLESS
- FIXING / FASTENING
- DRILLING / IMPACT DRILLING
- CONCRETE DRILLING / DEMOLITION
- CUTTING [CONCRETE/ MASONRY/ METAL]
- MULTI TOOL
- GRINDING
- SANDING / POLISHING
- SAWING
- ROUTERING / PLANING
- CLEANING
- HEAT GUN / LASERS
- PNEUMATIC TOOLS
- GARDEN TOOLS
- GENERATORS

Concrete Drilling / Demolition

Rotary Hammers, Chipping Hammers,
Demolition Hammers



ROTARY HAMMER: SELECTION CHART

■ Capacity of use tungsten carbide-tipped bit
■ Best size range for the model
■ Capacity of use for TCT core bits

O: OPTIMAL P: POSSIBLE

SIZE	MODEL	SHANK	AVT	JOULES	KG	10	20	30	40	50	60	70	80	90	100	110	120	130	140	150	160	Highly Reinforced Concrete	Concrete, Granite, Stone, Brick	Metal/ Wood	Working Direction	Drilling/ chiseling	
16mm	HR166D SDS-PLUS			1.1J	1.8kg	3.2 - 16																P	O	P	↕	100%	
	DHR171 SDS-PLUS			1.2J	1.2kg	3.2 - 17																	P	O	P	↕	100%
18mm	HR1841F SDS-PLUS		AVT	1.4J	2.5kg	4 - 18																	P	O	P	↕	87%
	DHR182 SDS-PLUS		AVT	1.7J	3.6kg	4 - 18																	P	O	P	↕	87%
20mm	HR2020 SDS-PLUS			2.2J	2.3kg	3.4 - 20																	P	O	P	↕	100%
	DHR202 SDS-PLUS			1.9J	2.9kg	4 - 20																	P	O	P	↕	87%
24mm	HR2475 SDS-PLUS			2.7J	3.0kg	4 - 24																	P	O	P	↕	87%
	DHR242 SDS-PLUS			2.0J	3.3kg	4 - 24																	P	O	P	↕	87%
26mm	HR2600 SDS-PLUS			2.9J	2.8kg	4 - 26																	P	O	P	↕	100%
	HR2630 SDS-PLUS			2.9J	2.8kg	4 - 26																	P	O	P	↕	87%
	HR2631F SDS-PLUS		AVT	2.9J	2.8kg	4 - 26																	P	O	P	↕	87%
	HR2630T SDS-PLUS			2.9J	2.8kg	4 - 26																	P	O	P	↕	87%
	HR2631FT SDS-PLUS		AVT	2.9J	2.8kg	4 - 26																	P	O	P	↕	87%
	HR2661 SDS-PLUS		AVT	2.9J	4.4kg	4 - 26																	P	O	P	↕	87%
	DHR263 SDS-PLUS			3.0J	4.7kg	4 - 26																	P	O	P	↕	87%
	HR2800 SDS-PLUS			2.9J	3.2kg	4 - 28																	P	O	P	↕	75%
28mm	HR2810 SDS-PLUS			2.9J	3.4kg	4 - 28																	P	O	P	↕	75%
	DHR283/81/80 SDS-PLUS		AVT	3.2J	5.1kg	4 - 28																	P	O	P	↕	75%
32mm	HR3200C SDS-PLUS			5.9J	4.8kg	4 - 32																	O	O	P	↕	75%
	HR3210C SDS-PLUS		AVT	5.5J	5.2kg	4 - 32																	O	O	P	↕	75%
35mm	HR3541FC SDS-MAX		AVT	6.3J	5.6kg	10 - 35																	O	O	P	↕	75%
	HR3530 17mm Hex			6.2J	5.3kg	10 - 35																	O	O	↕	75%	
40mm	HR4002 SDS-MAX			6.2J	6.6kg	10 - 40																	O	O	↕	75%	
	HR4030C 17mm Hex			9.2J	6.9kg	10 - 40																	O	O	↕	75%	
	HR4003C SDS-MAX			11.4J	6.2kg	10 - 40																	O	O	↕	75%	
	HR4013C SDS-MAX		AVT	11.4J	6.8kg	10 - 40																	O	O	↕	75%	
	DHR400 SDS-MAX		AVT	11.4J	7.3kg	10 - 40																	O	O	↕	75%	
45mm	HR4501C SDS-MAX			12.5J	8.2kg	10 - 45																	O	O	↕	63%	
	HR4511C SDS-MAX		AVT	12.5J	8.5kg	10 - 45																	O	O	↕	63%	
52mm	HR5202C SDS-MAX			21.0J	10.9kg	19 - 52																	O	O	↕	50%	
	HR5212C SDS-MAX		AVT	21.0J	11.9kg	19 - 52																	O	O	↕	50%	



ADAPTED FOR SDS-PLUS BITS



ADAPTED FOR SDS-MAX BITS



ADAPTED FOR HEX BITS

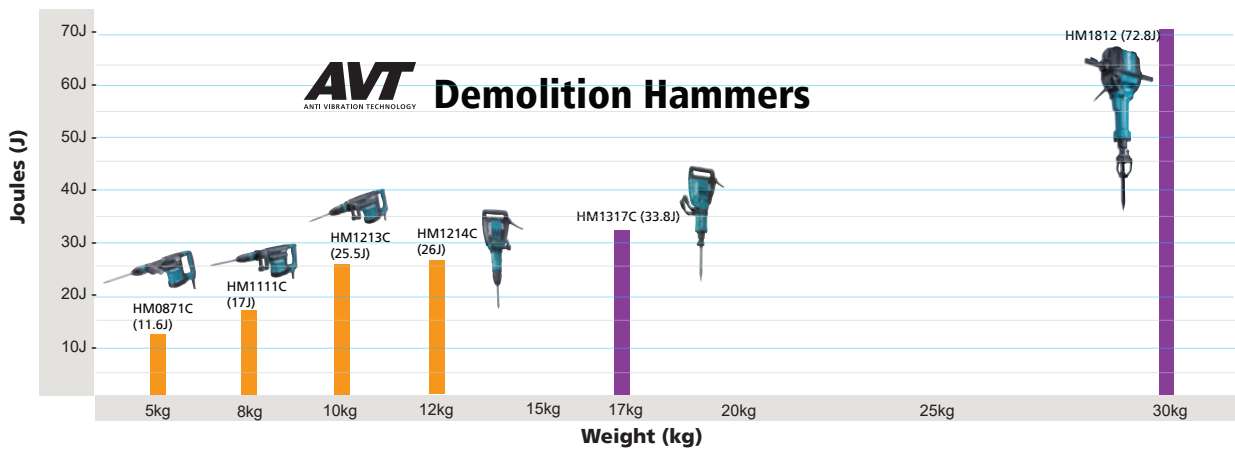
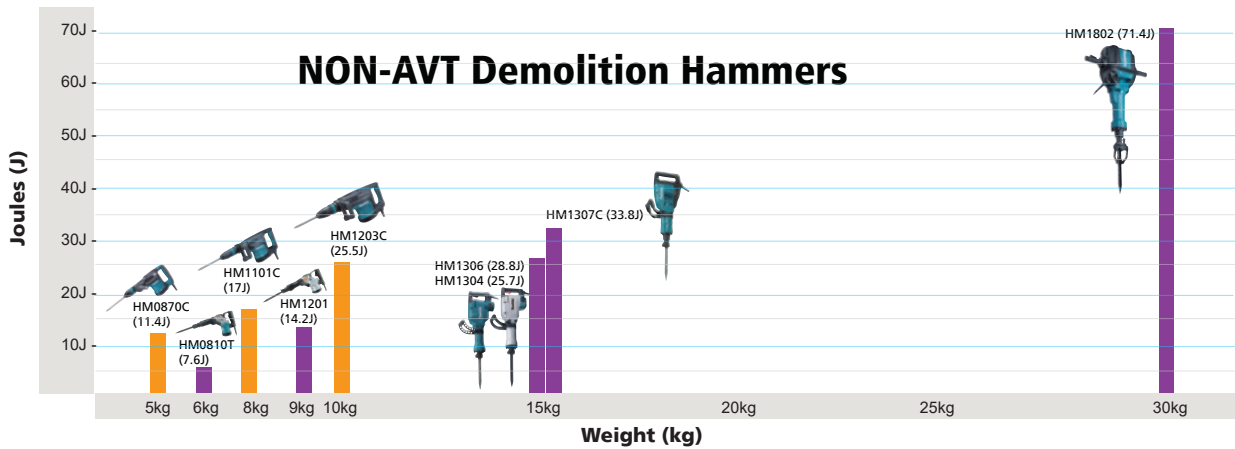
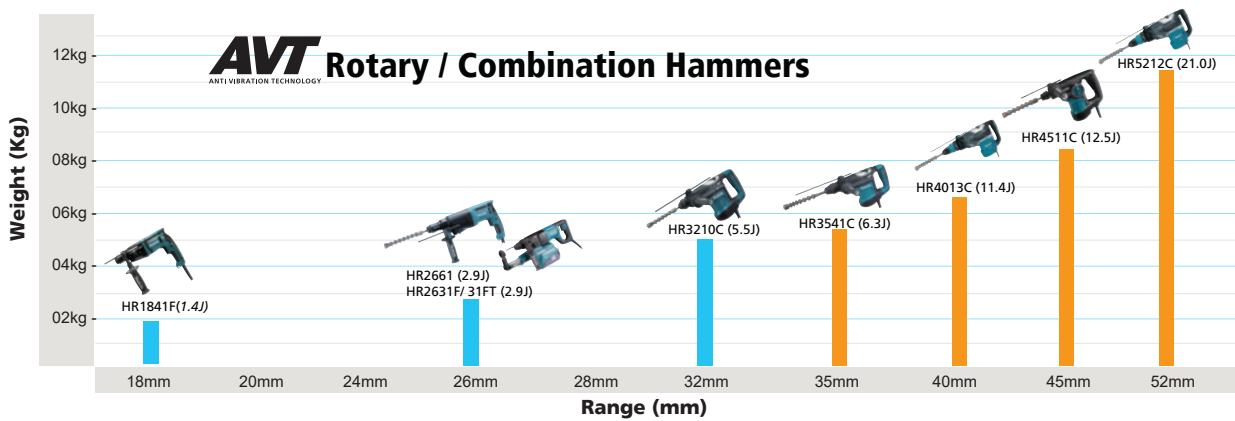
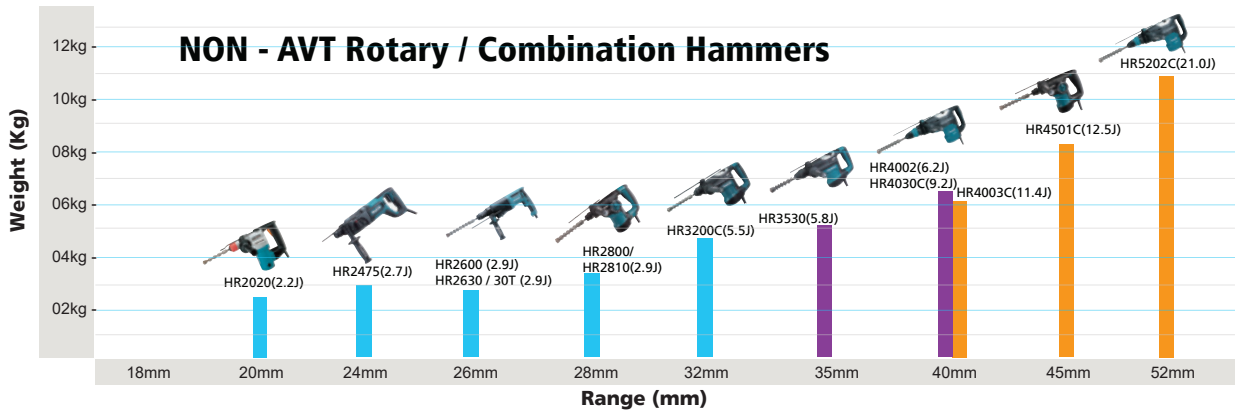

Anti Vibration Technology

The benchmark in vibration reduction Makita demolition tools are among the best in the world. Working with users to solve this problem, Makita's AVT products have been designed in close relation to users needs at site level.

Under load



Active Protection

Active dynamic absorber

Shift of air pressure in crank room and barrel room "actively" controls balancer to move opposite of piston.

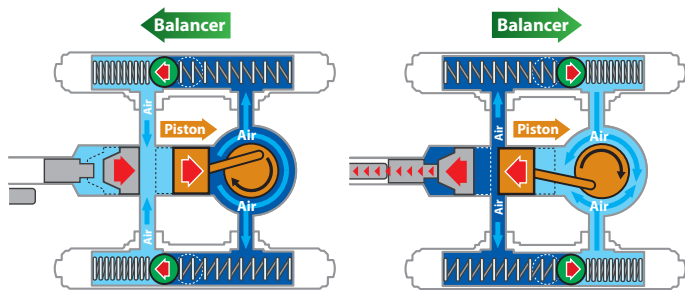

AVT

ANTI VIBRATION TECHNOLOGY



Passive Protection

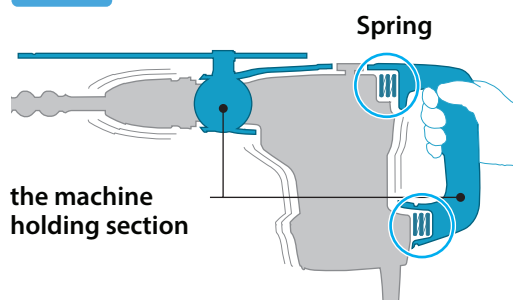

Vibration absorbing housing

The level of vibration is further reduced by completely separating the machine holding section from the motor/transmission section

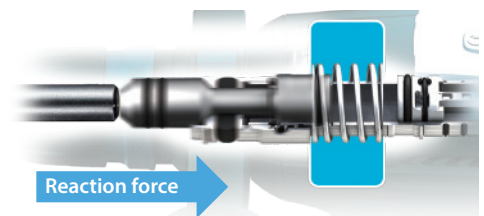

Damper spring

absorbs reaction force caused by drill bit at the moment of impact.

During No-load

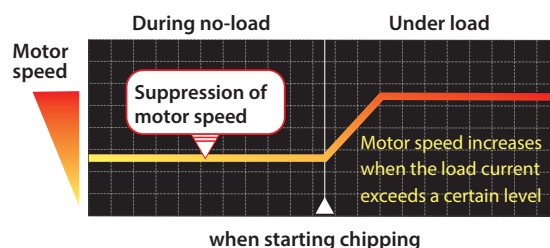

Soft no load function

- reduces vibration of tool body when idling, accordingly decreases the amount of vibration to operator's hands during a day's operation.
- minimizes deflection of bit tip from aiming point when starting chipping.

HR1841FJ 18mm - Adapted for SDS-PLUS Shank

Acc Pg. A062-079 **459**

Rotary Hammer



1.4 JOULES **AVT** ANTI VIBRATION TECHNOLOGY

First in the Class 18mm Rotary Hammer Equipped with AVT

- Anti-Vibration Technology (AVT) for best-in-class low vibration
- Compact AVT is our unique mechanism developed especially for small rotary hammers
- Compact with less weight

Specifications:-



Continuous rating input	470W
Impact Energy	1.4 J
Capacity	Concrete: 18 mm Core Bit: 35 mm / Diamond Core Bit (Dry Type): 65 mm Steel: 13 mm / Wood: 24 mm
Blows Per Minute (BPM)	0 - 4,800
No Load Speed (RPM)	0 - 2,100
Sound Pressure Level	87 dB(A)
Sound Power Level	98 dB(A)
Vibration Level	Hammer Drilling Into Concrete: 7.5 m/s ²
Dimensions (L x W x H)	285x75x208 mm
Net weight	2.0 - 2.5 kg
Power supply cord	2.5 m

Standard Equipment: Side Grip, Depth Gauge (Tool does not come with bit.)

Excellent drilling performance

Piston Stroke UP + **No load speed 0-2,100 min⁻¹** + **Impacts per minute 0-4,800 min⁻¹**

Reaction force

Damper spring + **Vibration absorbing housing**
absorbs reaction force + The level of vibration is reduced by separating from the vibrating section

AVT ANTI VIBRATION TECHNOLOGY

CORDLESS

FIXING / FASTENING

DRILLING / IMPACT DRILLING

CONCRETE DRILLING / DEMOLITION

CUTTING [CONCRETE/ MASONRY/ METAL]

MULTI TOOL

GRINDING

SANDING / POLISHING

SAWING

ROUTERING / PLANING

CLEANING

HEAT GUN / LASERS

PNEUMATIC TOOLS

GARDEN TOOLS

GENERATORS

HR2010 20mm - Adapted for SDS-PLUS Shank

Acc Pg. A062-079 **105**

Rotary Hammer - Adapted for SDS-PLUS Shank



1.7 JOULES

Compact, yet tough and durable.

- Easy bit change with one-touch slide chuck.
- Torque limiting clutch disengages if bit jams.

Specifications:-



Continuous rating Input	600W
Capacity	Concrete : 20mm (13/16") Steel : 13mm (1/2") Wood : 24mm (15/16")
Impacts per minute	0-4,000ipm
No load speed	0-900rpm
Sound pressure level	86dB(A)
Sound power level	97dB(A)
Overall length	302mm (11-1/4")
Net weight	3.4kg (7.4lbs)
Power supply cord	5.0m (16.4ft)

Standard Equipment: Depth Gauge, Grip (Tool does not come with bit.)

HR2020 20mm - Adapted for SDS-PLUS Shank

Acc Pg. A062-079 **419**

Rotary Hammer



2.2 JOULES

Simple and solid construction, yet powerful performance.

- 2 operation modes -hammering with rotation and rotation only.
- Variable speed + reversible rotation.

Specifications:-



Continuous rating Input	710W
Capacity	Concrete : 20mm (3/4") Steel : 13mm (1/2") Wood : 32mm (1-1/4")
Impacts per minute	0-4,050 ipm
No load speed	0-1,050rpm
Sound pressure level	86dB(A)
Sound power level	97dB(A)
Overall length	352mm (13-7/8")
Net weight	2.3kg (5.1lbs)
Power supply cord	4.0m (13.1ft)

Standard Equipment: Depth Gauge, Grip. (Tool does not come with bit)

CORDLESS
FIXING / FASTENING
DRILLING / IMPACT DRILLING
CONCRETE DRILLING / DEMOLITION
CUTTING [CONCRETE/ MASONRY/ METAL]
MULTI TOOL
GRINDING
SANDING / POLISHING
SAWING
ROUTERING / PLANING
CLEANING
HEAT GUN / LASERS
PNEUMATIC TOOLS
GARDEN TOOLS
GENERATORS

HR2432 24mm - Adapted for SDS-PLUS Shank Acc Pg. A062-079 **419** 

Combination Hammer
With Dust Extraction



2.2 JOULES

Features dust extraction, ensuring clean operation.

- Big fan provides incredibly high dust extraction power.
- Elbow-shaped nozzle prevents the hose from dangling down to reduce the possibility of hose breakage.
- Ideal for overhead application.
- Suitable for house-remodeling jobs to avoid dust.
- Versatile 3 mode: Rotation Only, Hammering with Rotation & Hammering Only.

Specifications:- 

Continuous rating input	780W
Capacity	Concrete (with T.C.T. bit) : 24mm (15/16") Steel : 13mm (1/2") Wood : 32mm (1-1/4")
Impacts per minute (ipm)	0-4,500
No load speed (rpm)	0-1,000
Sound pressure level	87dB(A)
Sound power level	98dB(A)
Vibration level	Chiseling: 9.5m/s ² / Hammer drilling: 13.5m/s ² Drilling: 7.5m/s ²
Dimensions (L x W x H)	407x120x220mm (16"x4-3/4"x8-3/4")
Net weight	3.2kg (6.9lbs)
Power supply cord	4.0m (13.1ft)

Standard Equipment: Side Grip, Cap, Dust Bag. (Tool does not come with bit)

HR2475 24mm - Adapted for SDS-PLUS Shank Acc Pg. A062-079 **419** 

Combination Hammer



2.7 JOULES

High durability in mechanical parts, motor and carbon brush.

- 3 operation modes - hammering, hammering with rotation, and rotation only.
- Ergonomic D-shaped handle with rubberized soft grip provides more comfort and better control while minimizing hand fatigue and pain.
- One-touch sliding chuck for easy bit changes.

Specifications:- 

Continuous rating input	780W
Capacity	Concrete : 24mm (15/16") Steel : 13mm (1/2") Wood : 32mm (1-1/4")
Impacts per minute (ipm)	0-4,500
No load speed (rpm)	0-1,100
Sound pressure level	89dB(A)
Sound power level	100dB(A)
Vibration level	Chiseling: 10.5m/s ² / hammer drilling: 15.5m/s ² Drilling: 3m/s ²
Dimensions (L x W x H)	429x84x158mm (16-7/8"x3-5/16"x6-1/4")
Net weight	3.0kg (6.6lbs)
Power supply cord	4.0m (13.1ft)

Standard Equipment: Side Handle, Depth Gauge. (Tool does not come with bit)

HR2600 26mm - Adapted for SDS-PLUS Shank Acc Pg. A062-079 **325** 

Rotary Hammer



2.9 JOULES

2 Operation Modes: Hammering with rotation & Rotation only.

- Reverse function on brush holder.
- Large trigger switch.

Specifications:- 

Continuous rating input	800W
Capacity	Concrete : 26mm (1") Steel : 13mm (1/2") Wood : 32mm (1-1/4")
Impacts per minute (ipm)	0 - 4,600
No load speed (rpm)	0 - 1,200
Sound pressure level	91dB(A)
Sound power level	102dB(A)
Vibration level	Hammer drilling: 15.5m/s ² / Drilling: 2.5m/s ²
Dimensions (L x W x H)	361x77x209mm (14-1/4"x3"x8-1/4")
Net weight	2.8kg (6.2lbs)
Power supply cord	2.5m (8.2ft)

Standard Equipment: Side Grip, Depth Gauge. (Tool does not come with bit)

HR2630 26mm - Adapted for SDS-PLUS Shank Acc Pg. A062-079 **325** 

Combination Hammer



2.9 JOULES

Easy-to-grip handle ergonomically designed to give maximum power thrust.

- 3 operation modes - hammering, hammering with rotation, rotation.
- Less bit wobbling.
- One-touch sliding chuck for easy bit change.
- Operation mode change lever positioned on the bottom of gear housing for reduced possibility of breakage.

Specifications:- 

Continuous rating input	800W
Capacity	Concrete : 26mm (1") Steel : 13mm (1/2") Wood : 32mm (1-1/4")
Impacts per minute (ipm)	0-4,600
No load speed (rpm)	0-1,200
Sound pressure level	91dB(A)
Sound power level	102dB(A)
Vibration level	Hammer drilling: 15.5m/s ² / Chiseling: 9.5m/s ² Drilling: 2.5m/s ²
Dimensions (L x W x H)	361x77x209mm (14-1/4"x3"x8-1/4")
Net weight	2.8kg (6.2lbs)
Power supply cord	2.5m (8.2ft)

Standard Equipment: Side Grip, Depth Gauge. (Tool does not come with bit)

HR2630T 26mm - Adapted for SDS-PLUS Shank Acc Pg. A062-079 **325** 

Combination Hammer



Easy-to-grip handle ergonomically designed to give maximum power thrust

- 3 operation modes - hammering, hammering with rotation, rotation.
- Less bit wobbling.
- One-touch sliding chuck for easy bit change.
- Operation mode change lever positioned on the bottom of gear housing for reduced possibility of breakage.
- Quick change drill chuck from SDS-plus to 3 jaw chuck literally in a second

Specifications:- 

Continuous rating input	800W
Capacity	Concrete : 26mm (1") Steel : 13mm (1/2") Wood : 32mm (1-1/4")
Impacts per minute (ipm)	0-4,600
No load speed (rpm)	0-1,200
Sound pressure level	91dB(A)
Sound power level	102dB(A)
Vibration level	Hammer drilling: 15m/s ² / Chiseling: 9,5m/s ² Drilling: 2,5m/s ²
Dimensions (L x W x H)	385x77x209mm (15-1/8"x3"x8-1/4")
Net weight	3.0kg (6.6lbs)
Power supply cord	2.5m (8.2ft)

Standard Equipment: Quick change drill chuck, Side grip, Depth gauge
(Tool does not come with bit)

HR2611F 26mm - Adapted for SDS-PLUS Shank Acc Pg. A062-079 **325** 

Combination Hammer



3 Operation Modes: Hammering, Hammering with Rotation and Rotation only.

- Reverse function on brush holder
- Large trigger switch

Specifications:- 

Continuous rating Input	800W
Capacity	Concrete: 26mm (1") Steel: 13mm (1/2") Wood: 32mm (1-1/4")
Impacts per minute (ipm)	0 - 4,600
No load speed (rpm)	0 - 1,200
Sound pressure level	90dB(A)
Sound power level	101dB(A)
Dimensions (L x W x H)	361 x 77 x 202mm (14-1/4" x 3" x 8")
Vibration	11.5m/s ²
Net weight	2.8kg (6.2lbs)
Power supply cord	2.5m (8.2ft)

Standard Equipment: Side Grip, Depth Gauge. (Tool does not come with bit)

HR2631F 26mm - Adapted for SDS-PLUS Shank Acc Pg. A062-079 **325** 

Combination Hammer



Easy-to-grip handle ergonomically designed to give maximum power thrust.

- 3 operation modes - hammering, hammering with rotation, rotation.
- Less bit wobbling.
- One-touch sliding chuck for easy bit change.
- Operation mode change lever positioned on the bottom of gear housing for reduced possibility of breakage.
- Features a built-in LED Job Light.

Specifications:- 

Continuous rating input	800W
Capacity	Concrete : 26mm (1") Steel : 13mm (1/2") Wood : 32mm (1-1/4")
Impacts per minute (ipm)	0 - 4,600
No load speed (rpm)	0 - 1,200
Sound pressure level	90dB(A)
Sound power level	101dB(A)
Vibration level	Hammer drilling: 12m/s ² Chiseling: 9m/s ² / Drilling: 2.5m/s ²
Dimensions (L x W x H)	361x77x209mm (14-1/4" x3"x8-1/4")
Net weight	2.9kg (6.4lbs)
Power supply cord	2.5m (8.2ft)

Standard Equipment: Side Grip, Depth Gauge. (Tool does not come with bit)

HR2611FT 26mm - Adapted for SDS-PLUS Shank Acc Pg. A062-079 **325** 

Combination Hammer



3 Operation Modes: Hammering, Hammering with Rotation, and Rotation only.

- Reverse function on brush holder.
- Large trigger switch.

Specifications:- 

Continuous rating Input	800W
Capacity	Concrete: 26mm (1") Steel: 13mm (1/2") Wood: 32mm (1-1/4")
Impacts per minute (ipm)	0 - 4,600
No load speed (rpm)	0 - 1,200
Sound pressure level	90dB(A)
Sound power level	101dB(A)
Vibration	11.5m/s ²
Dimensions (L x W x H)	361 x 77 x 202mm (14-1/4" x 3" x 8")
Net weight	2.8kg (6.2lbs)
Power supply cord	2.5m (8.2ft)

Standard Equipment: Quick change drill chuck, Side grip, Depth gauge
(Tool does not come with bit)

CORDLESS

FIXING / FASTENING

DRILLING / IMPACT DRILLING

CONCRETE DRILLING / DEMOLITION

CUTTING [CONCRETE/ MASONRY/ METAL]

MULTI TOOL

GRINDING

SANDING / POLISHING

SAWING

ROUTERING / PLANING

CLEANING

HEAT GUN / LASERS

PNEUMATIC TOOLS

GARDEN TOOLS

GENERATORS

- CORDLESS
- FIXING / FASTENING
- DRILLING / IMPACT DRILLING
- CONCRETE DRILLING / DEMOLITION
- CUTTING [CONCRETE/ MASONRY/ METAL]
- MULTI TOOL
- GRINDING
- SANDING / POLISHING
- SAWING
- ROUTERING / PLANING
- CLEANING
- HEAT GUN / LASERS
- PNEUMATIC TOOLS
- GARDEN TOOLS
- GENERATORS

HR2631FT 26mm - Adapted for SDS-PLUS Shank Acc Pg. A062-079 **325** W

Combination Hammer



2.9 JOULES AVT ANTI VIBRATION TECHNOLOGY

3 Operation Modes: Hammering, Hammering with Rotation, and Rotation only.

- Less bit wobbling.
- One-touch sliding chuck for easy bit change.
- Operation mode change lever positioned on the bottom of gear housing for reduced possibility of breakage.
- Features a built-in LED Job Light.

Specifications:-

Continuous rating input	800W
Capacity	Concrete : 26mm (1") Steel : 13mm (1/2") Wood : 32mm (1-1/4")
Impacts per minute (ipm)	0 - 4,600
No load speed (rpm)	0 - 1,200
Sound pressure level	90dB(A)
Sound power level	101dB(A)
Vibration level	Hammer drilling: 12m/s ² Chiseling: 9m/s ² / Drilling: 2.5m/s ²
Dimensions (L x W x H)	361x77x209mm (14-1/4" x 3" x 8-1/4")
Net weight	2.9kg (6.4lbs)
Power supply cord	2.5m (8.2ft)

Standard Equipment: Quick change drill chuck, Side grip, Depth gauge (Tool does not come with bit)

HR2661 26mm - Adapted for SDS-PLUS Shank Acc Pg. A062-079 **419** W

Combination Hammer With Self Dust Collection System



2.9 JOULES AVT ANTI VIBRATION TECHNOLOGY

26mm AVT D-Handle Combination Hammer with HEPA Self Dust Collection, SDS-PLUS Bits

- HEPA Filter Removes Particles with an Efficiency Rating of 99.75%
- Dust collecting port on telescopic guide with a sliding range of 190 mm
- Secure connection between dust case and dust collecting section for less dust leakage
- See-through dust case for easy checking of collected dust amount
- Easy dust case removal for convenient dust disposal and cleaning

Specifications:-

Continuous rating input	800W
Capacity	2.9 J Concrete: 26 mm / Core Bit: 68 mm Diamond Core Bit (Dry Type): 80 mm Steel: 13 mm / Wood: 32 mm
Impacts per minute (ipm)	0 - 4,500
No load speed (rpm)	0 - 1,100
Sound pressure level	90 dB(A)
Sound power level	101 dB(A)
Vibration level	Hammer Drilling Into Concrete: 9.5 m/s ²
Dimensions (L x W x H)	666x89x228 mm
Net weight	4.4 kg
Power supply cord	2.5 m

Standard Equipment: Side Grip, Depth Gauge, Sealing Cap (Tool does not come with bit)

Self Dust Collection System for model HR2661 26mm - Adapted for SDS-PLUS Shank



High dust collection performance for overhead application

Dust collection rate for overhead application

High

Keeps high efficient dust collection

Diameter of drill bit: 10.5mm,
Drilling depth: 60mm,
Test material: Concrete with compressive strength of 40N/mm²

Low

Large Fan Provides Incredibly High Dust Extraction Power

65 mm High rotation speed **20,900 min⁻¹**

Secure connection between dust case and dust collecting section allows for less dust leakage

Easy disposal of dust and easy cleaning of dust case

- Dust case cover is easy to open/close with a single operation of a locking tab
- Wide opening of dust case



Transparent dust case for easy checking of collected dust amount

Equipped with HEPA Filter

which removes particles with an efficiency rating of 99.75% from the air passing through.

HEPA filter



HR2800 28mm - Adapted for SDS-PLUS Shank Acc Pg. A062-079 **325** 

Rotary Hammer



2.9
JOULES

2 Operation Modes: Hammering with Rotation & Rotation only.

- Highest-in-class efficiency in both drilling and chipping.
- Compact L-shaped motor housing.
- One-touch sliding chuck enables easy bit changes.
- Ergonomically designed handle with rubberized grip provides more control and comfort.

Specifications:- 

Continuous rating input	800W
Capacity	Concrete (with T.C.T. bit) : 28mm (1-1/8") Steel : 13mm (1/2") Wood : 32mm (1-1/4")
Impacts per minute (ipm)	0 - 4,500
No load speed (rpm)	0 - 1,100
Sound pressure level	89dB(A)
Sound power level	100dB(A)
Vibration level	Hammer drilling: 20m/s ² / Drilling: 2.5m/s ²
Dimensions (L x W x H)	314x89x225mm (12-3/8" x3-1/2" x8-7/8")
Net weight	3.2kg (7.1lbs)
Power supply cord	2.5m (8.2ft)

Standard Equipment: Depth Gauge, Side Grip. (Tool does not come with bit)

HR2810 28mm - Adapted for SDS-PLUS Shank Acc Pg. A062-079 **325** 

Combination Hammer



2.9
JOULES

3 Operation Modes: Hammering, Hammering with Rotation and Rotation only.

- Highest-in-class efficiency in both drilling and chipping.
- Compact L-shaped motor housing.
- One-touch sliding chuck enables easy bit changes.
- Ergonomically designed handle with rubberized grip provides more control and comfort.

Specifications:- 

Continuous rating input	800W
Capacity	Concrete (with T.C.T. bit) : 28mm (1-1/8") Steel : 13mm (1/2") Wood : 32mm (1-1/4")
Impacts per minute (ipm)	0-4,500
No load speed (rpm)	0-1,100
Sound pressure level	89dB(A)
Sound power level	100dB(A)
Vibration level	Chiseling: 15.5m/s ² , Hammer drilling: 20m/s ² Drilling: 2.5m/s ²
Dimensions (L x W x H)	314x89x225mm (12-3/8" x3-1/2" x8-7/8")
Net weight	3.2kg (7.1lbs)
Power supply cord	2.5m (8.2ft)

Standard Equipment: Side Grip, Depth Gauge. (Tool does not come with bit)

HR3200C 32mm - Adapted for SDS-PLUS Shank Acc Pg. A062-079 **350** 

Combination Hammer



5.5
JOULES

Developed as the successor model of HR3000C

- Simple Single-Lever Control to change the tool's operation mode.
- One-Touch sliding chuck for easy bit changes.
- Increased Repairability - with simplified wiring and bit holding mechanism.

Specifications:- 

Continuous rating input	850W
Capacity	Concrete (with T.C.T. bit) : 32mm (1-1/4") Steel : 13mm (1/2") Wood : 32mm (1-1/4")
Impacts per minute (ipm)	1,650-3,300
No load speed (rpm)	315-630
Sound pressure level	89dB(A)
Sound power level	100dB(A)
Vibration level	Hammer drilling: 18m/s ² , Chiseling: 12.5m/s ² Drilling: 2.5m/s ²
Dimensions (L x W x H)	398x108x239mm (15-5/8" x4-1/4" x9-3/8")
Net weight	4.8kg (10.5lbs)
Power supply cord	5.0m (16.4ft)

Standard Equipment: Side handle, Depth gauge, Bit grease, Plastic carrying case, Cleaning cloth (Tool does not comes with bit.)

HR3210C 32mm - Adapted for SDS-PLUS Shank Acc Pg. A062-079 **350** 

Combination Hammer



5.5
JOULES

Featuring low vibration level and lightweight design for optimal efficiency.

- Simple Single-Lever Control to change the tool's operation mode.
- One-Touch sliding chuck for easy bit changes.
- Increased Repairability - with simplified wiring and bit holding mechanism.

Specifications:- 

Continuous rating input	850W
Capacity	Concrete (with T.C.T. bit) : 32mm (1-1/4") Steel : 13mm (1/2"), Wood : 32mm (1-1/4") Concrete (with Core bit) : 90mm (3-1/2")
Impacts per minute (ipm)	1,650-3,300
No load speed (rpm)	315-630
Sound pressure level	89dB(A)
Sound power level	100dB(A)
Vibration level	Hammer drilling: 10m/s ² , Chiseling: 7.5m/s ² Drilling: 2.5m/s ²
Dimensions (L x W x H)	398x114x239mm (15-5/8" x4-1/2" x9-3/8")
Net weight	5.2kg (11.4lbs)
Power supply cord	5.0m (16.4ft)

Standard Equipment: Side handle, Depth gauge, Bit grease, Cleaning cloth (Tool does not comes with bit.)

CORDLESS

FIXING / FASTENING

DRILLING / IMPACT DRILLING

CONCRETE DRILLING / DEMOLITION

CUTTING [CONCRETE / MASONRY / METAL]

MULTI TOOL

GRINDING

SANDING / POLISHING

SAWING

ROUTERING / PLANING

CLEANING

HEAT GUN / LASERS

PNEUMATIC TOOLS

GARDEN TOOLS

GENERATORS

- CORDLESS
- FIXING / FASTENING
- DRILLING / IMPACT DRILLING
- CONCRETE DRILLING / DEMOLITION
- CUTTING [CONCRETE/ MASONRY/ METAL]
- MULTI TOOL
- GRINDING
- SANDING / POLISHING
- SAWING
- ROUTERING / PLANING
- CLEANING
- HEAT GUN / LASERS
- PNEUMATIC TOOLS
- GARDEN TOOLS
- GENERATORS



HR3530 35mm - Adapted for Hex Shank

Acc Pg. A067-079 **350**

Rotary Hammer



High work efficiency.

- Compact and lightweight design.
- No hammering while idling.
- Ergonomically designed handle with rubberized grip provides more control and comfort.
- Auto cut-out Carbon Brush.

Specifications:-



Continuous rating input	1,010W
Capacity	Concrete (with Core bit) : 105mm (4-1/8")
Impacts per minute (ipm)	3,100
No load speed (rpm)	760
Sound pressure level	91dB(A)
Sound power level	102dB(A)
Vibration level	Chiseling: 12.5m/s ² / Hammer drilling: 19.5m/s ²
Dimensions (L x W x H)	374x100x243mm (14-3/4" x3-15/16" x9-9/16")
Net weight	5.8kg (12.8lbs)
Power supply cord	5.0m (16.4ft)

Standard Equipment: Side Grip, Depth gauge (Tool does not come with bit.)

HR3540C 35mm - Adapted for SDS-MAX Shank

Acc Pg. A065-079 **350**

Combination Hammer



High performance features high work efficiency especially in drilling with large diameter bits.

- Change lever positioned on the top of the machine for reduced possibility of breakage even if the machine is carelessly kept down to rest.
- One-touch sliding chuck for easy bit changes.
- Constant speed and soft start features by electrical control.
- LED lamp indicates when to replace carbon brush.
- LED lamp is provided as a pilot lamp.

Specifications:-



Continuous rating input	850W
Capacity	Concrete (with T.C.T. bit) : 35mm (1-3/8") Steel : 13mm (1/2"), Wood : 32mm (1-1/4") Concrete (with Core bit) : 90mm (3-1/2")
Impacts per minute (ipm)	1,650 - 3,300
No load speed (rpm)	315 - 630
Sound pressure level	93dB(A)
Sound power level	104dB(A)
Vibration level	Chiseling: 12.5m/s ² / Hammer drilling: 18m/s ² Drilling: 2.5m/s ²
Dimensions (L x W x H)	439x108x239mm (17-1/4" x4-1/4" x9-3/8")
Net weight	5.2kg (11.4lbs)
Power supply cord	5.0m (16.4ft)

Standard Equipment: Depth Gauge, Side Handle (Bar-shaped), Bit Grease (Tool does not come with bit.)

HR3541FC 35mm - Adapted for SDS-MAX Shank

Acc Pg. A065-079 **350**

Combination Hammer



AVT(Anti-Vibration Technology) ensures extra-low vibration performance.

- Vibration absorbing handle provides comfortable operation.
- LED Job light with afterglow function.
- Change lever positioned on the top of the machine for reduced possibility of breakage even if the machine is carelessly kept down to rest.
- Constant speed and soft start features by electrical control.
- LED lamp indicates when to replace carbon brush.

Specifications:-





Continuous rating input	850W
Capacity	Concrete (with T.C.T. bit) : 35mm (1-3/8") Steel : 13mm (1/2"), Wood : 32mm (1-1/4") Concrete (with Core bit) : 90mm (3-1/4")
Impacts per minute (ipm)	1,650 - 3,300
No load speed (rpm)	315 - 630
Sound pressure level	91dB(A)
Sound power level	102dB(A)
Vibration level	Chiseling: 9m/s ² / Hammer drilling: 11m/s ² Drilling: 2.5m/s ²
Dimensions (L x W x H)	439x114x239mm (17-1/4" x4-1/2" x9-3/8")
Net weight	5.6kg (12.3lbs)
Power supply cord	5.0m (16.4ft)

Standard Equipment: Depth Gauge, Side Handle (Bar-shaped), Bit Grease (Tool does not come with bit.)

HR4003C 40mm - Adapted for SDS-MAX Shank **Acc Pg. A065-079** **350**mm

Rotary Hammer

11.4 JOULES

Most powerful and efficient in the class

- New "Two on/off switches switchable in hammering mode".
- Easy-to-operate operation mode change lever.

Specifications:-

Continuous rating input	1,100W
Capacity	Concrete (with T.C.T. bit) : 40mm (1-9/16") Concrete (with Core bit) : 105mm (4-1/8")
Impacts per minute (ipm)	1,450 - 2,900
No load speed (rpm)	250-500
Sound pressure level	92dB(A)
Sound power level	103dB(A)
Vibration level	Chiseling: 9m/s ² / Hammer drilling: 10m/s ²
Dimensions (L x W x H)	479x106x263mm (18-11/16"x4-3/16"x10-3/8")
Net weight	6.2kg (13.8lbs)
Power supply cord	5.0m (16.4ft)

Standard Equipment: Depth gauge, Side handle, Bit grease (Tool does not come with bit)

HR4001C 40mm - Adapted for SDS-MAX Shank **Acc Pg. A065-079** **350**mm

Rotary Hammer



9.5 JOULES

Most powerful and efficient in the class future style hammer from Makita.

- Achieves most efficient hammer with satisfying powerful performance.
- Selectable-switch feature gives the choice of trigger switch for drilling and lock-on slide switch for demolition for long hours.

Specifications:-

Continuous rating Input	1,100W
Capacity	Concrete (with T.C.T. bit) : 40mm (1-9/16") Concrete (with Core bit) : 105mm (4-1/8")
Impacts per minute (ipm)	1,350-2,750
No load speed (rpm)	235-480
Sound pressure level	90dB(A)
Sound power level	101dB(A)
Vibration level	Chiseling: 10.5m/s ² / Hammer drilling: 12.5m/s ²
Dimensions (L x W x H)	468x106x261mm (18-1/2"x4-3/16"x10-1/4")
Net weight	5.9kg (13.0lbs)
Power supply cord	5.0m (16.4ft)

Standard Equipment: Depth Gauge, Grip Assembly, Grease Vessel (Tool does not come with bit)

HR4013C 40mm - Adapted for SDS-MAX Shank **Acc Pg. A065-079** **350**mm

Rotary Hammer



11.4 JOULES

AVT
ANTI VIBRATION TECHNOLOGY
& SOFT
NO LOAD

ADVANCED
Vibration Control
Extra Comfort with unrivalled low level of vibration

High efficiency and unrivalled low level of vibration

- Soft no load function automatically reduces the motor speed during idling to suppress the vibration of the machine body.
- New "Two on/off switches switchable in hammering mode".
- Easy-to-operate operation mode change lever.

Vibration absorbing housing
This is the new AVT mechanism advanced from the current "Vibration absorbing handle".

The level of vibration is further reduced by completely separating the machine holding section from the motor/transmission section



Active dynamic vibration absorber
ensures operation with extremely low vibration. allows tool design with at body sides for better handling.

Damper spring
absorbs reaction force caused by drill bit at the moment of impact.

Specifications:-

Continuous rating input	1,100W
Capacity	Concrete (with T.C.T. bit) : 40mm (1-9/16") Concrete (with Core bit) : 105mm (4-1/8")
Impacts per minute (ipm)	1,450 - 2,900
No load speed (rpm)	250-500
Sound pressure level	92dB(A)
Sound power level	103dB(A)
Vibration level	Chiseling: 4.5m/s ² / Hammer drilling: 5m/s ²
Dimensions (L x W x H)	479x112x263mm (18-11/16"x4-3/8"x10-3/8")
Net weight	6.8kg (15.1lbs)
Power supply cord	5.0m (16.4ft)

Standard Equipment: Depth gauge, Side handle, Bit grease (Tool does not come with bit)

CORDLESS

FIXING / FASTENING

DRILLING / IMPACT DRILLING

CONCRETE DRILLING / DEMOLITION

CUTTING [CONCRETE / MASONRY / METAL]

MULTI TOOL

GRINDING

SANDING / POLISHING

SAWING

ROUTERING / PLANING

CLEANING

HEAT GUN / LASERS

PNEUMATIC TOOLS

GARDEN TOOLS

GENERATORS

- CORDLESS
- FIXING / FASTENING
- DRILLING / IMPACT DRILLING
- CONCRETE DRILLING / DEMOLITION
- CUTTING [CONCRETE/ MASONRY/ METAL]
- MULTI TOOL
- GRINDING
- SANDING / POLISHING
- SAWING
- ROUTERING / PLANING
- CLEANING
- HEAT GUN / LASERS
- PNEUMATIC TOOLS
- GARDEN TOOLS
- GENERATORS

HR4030C 40mm - Adapted for Hex Shank Acc Pg. A067-079 **350** 

Rotary Hammer



9.2 JOULES

Make tough jobs easier with electronic control features and compact design. (Hex Shank type)

- No hammering while idling.
- When drill bit hits against reinforcements, torque limiter operates to stop.
- Aluminum housing provides high quality and toughness.
- Auto cut-out carbon brush.
- Electronic variable speed control dial enables to select speed to job.

Specifications:- 

Continuous rating input	1,100W
Capacity	Concrete (with T.C.T. bit) : 40mm (1-9/16") Concrete (with Core bit) : 118mm (4-5/8")
Impacts per minute (ipm)	1,300 - 2,600
No load speed (rpm)	230 - 460
Sound pressure level	92dB(A)
Sound power level	103dB(A)
Vibration level	9m/s ²
Dimensions (L x W x H)	413x107x247mm (16-1/4"x4-1/4"x9-3/4")
Net weight	6.9kg (15.2lbs)
Power supply cord	5.0m (16.4ft)

Standard Equipment: Depth Gauge, Side Grip (Tool does not come with bit.)

HR4501C 45mm - Adapted for SDS-MAX Shank Acc Pg. A065-079 **175** 

Rotary Hammer



12.5 JOULES

High performance and durability.

- 2 operation modes - hammering and hammering with rotation.
- Selectable two on/off switches on demolition mode.
- One-Touch Sliding Chuck enables easy bit change.
- Ergonomically designed handle with rubberized grip provides more control and comfort.

Specifications:- 

Continuous rating input	1,350W
Capacity	Concrete (with T.C.T. bit) : 45mm (1-3/4") Concrete (with Core bit) : 125mm (5")
Impacts per minute (ipm)	1,250 - 2,750
No load speed (rpm)	130 - 280
Sound pressure level	94dB(A)
Sound power level	105dB(A)
Vibration level	Hammer drilling: 16m/s ² / Chiseling: 12.5m/s ²
Dimensions (L x W x H)	458x121x288mm (18"x4-3/4"x11-3/8")
Net weight	8.2kg (18.1lbs)
Power supply cord	5.0m (16.4ft)

Standard Equipment: Side Handle(D), Side Grip, Depth Gauge, Grease Vessel (Tool does not come with bit.)

HR4500C 45mm - Adapted for SDS-MAX Shank Acc Pg. A065-079 **155** 

Rotary Hammer



8.6 JOULES

Outstanding performer that professionals can count on.

- Electronic speed control with variable speed dial for maximum productivity.
- Reduced vibration for less operator fatigue.
- Service reminder light indicates when carbon brushes need replacement or switch / cord needs service.
- 2 operation mode, rotation with hammering and hammering only.

Specifications:- 

Continuous rating Input	1,300W
Max. bit dia.	45mm (1-3/4")
Max. core bit dia.	125mm (4-7/8")
Blows per minute	1,250-2,550bpm
No load speed	120-240rpm
Overall length	488mm (19-1/4")
Net weight	7.8kg (17.2lbs)
Power supply cord	5.0m (16.4ft)

Standard Equipment: Depth Gauge, Grip Assembly, Grease Vessel (Tool does not come with bit.)

HR4511C 45mm - Adapted for SDS-MAX Shank Acc Pg. A065-079 **175** 

Rotary Hammer



12.5 JOULES **AVT**
ANTI VIBRATION TECHNOLOGY

High performance and low vibration. (with Vibration absorbing grip)

- 2 operation modes - hammering and hammering with rotation.
- AVT (Anti-Vibration Technology) Active Dynamic Vibration Absorber ensures extra-low vibration performance.
- One-Touch Sliding Chuck enables easy bit change.
- Ergonomically designed handle with rubberized grip provides more control and comfort.

Specifications:- 

Continuous rating input	1,350W
Capacity	Concrete (with T.C.T. bit) : 45mm (1-3/4") Concrete (with Core bit) : 125mm (5")
Impacts per minute (ipm)	1,250 - 2,750
No load speed (rpm)	130 - 280
Sound pressure level	94dB(A)
Sound power level	105dB(A)
Vibration level	Hammer drilling: 7.5m/s ² / Chiseling: 7.5m/s ²
Dimensions (L x W x H)	458x136x288mm (18"x5-3/8"x11-3/8")
Net weight	8.5kg (18.7lbs)
Power supply cord	5.0m (16.4ft)

Standard Equipment: Side Handle(D), Side Grip, Depth Gauge, Grease Vessel (Tool does not come with bit.)

HR5202C 52mm - Adapted for SDS-MAX Shank **Acc Pg. A065-079** **175** 

Rotary Hammer



21 

High efficiency and unrivalled low level of vibration.

- 2 operation modes - hammering and hammering with rotation.
- Ergonomically designed handle with rubberized soft grip provides more control and comfort.
- Selectable two on/off switches on demolition mode.
- One-Touch Sliding Chuck enables easy bit change

Specifications:- 

Continuous rating input	1,510W
Capacity	Concrete (with T.C.T. bit) : 52mm (2") Concrete (with Core bit) : 160mm (6-5/16")
Impacts per minute (ipm)	1,100 - 2,250
No load speed (rpm)	150 - 310
Sound pressure level	99dB(A)
Sound power level	110dB(A)
Vibration level	Chiseling: 10.5m/s ² / Hammer drilling: 17m/s ²
Dimensions (L x W x H)	599x134x287mm (23-1/2" x 5-1/4" x 11-1/4")
Net weight	10.9kg (24.1lbs)
Power supply cord	5.0m (16.4ft)

Standard Equipment: Side handle (D), Side grip, Depth gauge, Grease vessel

HR5211C 52mm - Adapted for SDS-MAX Shank **Acc Pg. A065-079** **175** 

Rotary Hammer



20 

AVT 

High performance and low vibration.(with Vibration absorbing grip)

- 2 operation modes - hammering and hammering with rotation.
- AVT (Anti-Vibration Technology) Active Dynamic Vibration Absorber ensures extra-low vibration performance.
- Ergonomically designed handle with rubberized grip provides more control and comfort.
- One-Touch Sliding Chuck enables easy bit change.

Specifications:- 

Continuous rating Input	1,500W
Capacity	Concrete (with T.C.T. bit): 52mm (2") Concrete (with Core bit): 160mm (6-1/4")
Impacts per minute	1,075-2,150bpm
No load speed	130-260rpm
Sound pressure level	100dB(A)
Sound power level	111dB(A)
Vibration level	Chiseling: 12m/s ² / Hammer drilling: 17m/s ²
Dimensions (L x W x H)	599 x 149 x 287mm (23-1/2" x 5-7/8" x 11-1/4")
Net weight	12.2kg (26.9 lbs)
Power supply cord	5.0m (16.4ft)

Standard Equipment: Side Handle(D), Side Grip, Depth Gauge, Grease Vessel
(Tool does not come with bit.)

HR5212C 52mm - Adapted for SDS-MAX Shank **Acc Pg. A065-079** **175** 

Rotary Hammer



21 

AVT 

ANTI VIBRATION TECHNOLOGY

& SOFT NO LOAD

ADVANCED

Vibration Control

Extra Comfort with unrivalled low level of vibration

High efficiency and unrivalled low level of vibration

- Soft no load function automatically reduces the motor speed during idling to suppress the vibration of the machine body.
- New "Two on/off switches switchable in hammering mode".
- Easy-to-operate operation mode change lever.

Vibration absorbing housing

This is the new AVT mechanism advanced from the current "Vibration absorbing handle".

The level of vibration is further reduced by completely separating the machine holding section from the motor/transmission section



Active dynamic vibration absorber ensures operation with extremely low vibration. allows tool design with at body sides for better handling.

Damper spring absorbs reaction force caused by drill bit at the moment of impact.

Specifications:- 

Continuous rating input	1,510W
Capacity	Concrete (with T.C.T. bit) : 52mm (2") Concrete (with Core bit) : 160mm (6-5/16")
Impacts per minute (ipm)	1,100 - 2,250
No load speed (rpm)	150 - 310
Sound pressure level	98dB(A)
Sound power level	109dB(A)
Vibration level	Chiseling: 8m/s ² / Hammer drilling: 9m/s ²
Dimensions (L x W x H)	599x140x287mm (23-1/2" x 5-1/2" x 11-1/4")
Net weight	11.9kg (26.2lbs)
Power supply cord	5.0m (16.4ft)

Standard Equipment: Side handle (D), Side grip, Depth gauge, Grease vessel

- CORDLESS
- FIXING / FASTENING
- DRILLING / IMPACT DRILLING
- CONCRETE DRILLING / DEMOLITION
- CUTTING [CONCRETE/ MASONRY/ METAL]
- MULTI TOOL
- GRINDING
- SANDING / POLISHING
- SAWING
- ROUTERING / PLANING
- CLEANING
- HEAT GUN / LASERS
- PNEUMATIC TOOLS
- GARDEN TOOLS
- GENERATORS

- CORDLESS
- FIXING / FASTENING
- DRILLING / IMPACT DRILLING
- CONCRETE DRILLING / DEMOLITION
- CUTTING [CONCRETE/ MASONRY/ METAL]
- MULTI TOOL
- GRINDING
- SANDING / POLISHING
- SAWING
- ROUTERING / PLANING
- CLEANING
- HEAT GUN / LASERS
- PNEUMATIC TOOLS
- GARDEN TOOLS
- GENERATORS

HM0810T 11/16" : Adapted for 17mm Hex Shank Acc Pg. A071-079 **105**

Chipping Hammer



7.6 JOULES

Perfect combination of power, durability and compact design.

- Compact and lightweight for maximum control.
- Soft rubber grip side handle and anti-vibration spring on rear handle for reduced operator fatigue.
- Easy to grip round shape barrel protected by rubber cover.
- One touch sliding chuck for easy bit installation and removal.

Specifications:-

Continuous rating input	900W
Impacts per minute (ipm)	2,900
Sound pressure level	92dB(A)
Sound power level	103dB(A)
Vibration level	Chiseling: 14m/s ²
Overall length	428mm (16-7/8")
Net weight	5.5kg (12.1lbs)
Power supply cord	5.0m (16.4ft)

Standard Equipment: Bull Point, Hex Wrench, Grip

HM0871C - Adapted for SDS-MAX Shank Acc Pg. A070-079 **350**

Chipping Hammer



11.6 JOULES **AVT** **SOFT** **NO LOAD**

AVT (Anti-Vibration Technology) ensures extra-low vibration performance.

- Soft no load function ensures low vibration performance.
- High durability and excellent demolition performance.
- One touch sliding chuck for easy bit installation and removal.
- LED lamp indicates when to replace carbon brush.
- LED lamp is provided as a pilot lamp.

Specifications:-

Continuous rating Input	1,100W
Impacts per minute (ipm)	1,100-2,650 ipm
Sound pressure level	86dB(A)
Sound power level	97dB(A)
Vibration level	Chiseling: 8m/s ²
Dimensions (L x W x H)	466 x 116 x 230mm (18-3/8" x 4-9/16" x 9")
Vibration	8.4 m/s ²
Net weight	5.6kg (12.4lbs)
Power supply cord	5.0m (16.4ft)

Standard Equipment: Grease for Bit, Side Handle. (Tool does not come with bull point)

HM0870C - Adapted for SDS-MAX Shank Acc Pg. A070-079 **350**

Chipping Hammer



11.4 JOULES

High durability and excellent demolition performance.

- One touch sliding chuck for easy bit installation and removal.
- LED lamp indicates when to replace carbon brush.
- LED lamp is provided as a pilot lamp.

Specifications:-

Continuous rating input	1,100W
Impacts per minute (ipm)	1,100-2,650
Sound pressure level	87dB(A)
Sound power level	98dB(A)
Vibration level	Chiseling: 11.5m/s ²
Dimensions (L x W x H)	449x109x230mm (17-3/4" x 4-1/4" x 9")
Net weight	5.1kg (11.1lbs)
Power supply cord	5.0m (16.4ft)

Standard Equipment: Grease for Bit, Side Handle. (Tool does not come with bull point)

HM1101C - Adapted for SDS-MAX Shank Acc Pg. A070-079 **175**

Demolition Hammer



17 JOULES

High durability and excellent demolition performance.

- One touch sliding chuck for easy bit installation and removal.
- LED lamp indicates when to replace carbon brush.
- LED lamp is provided as a pilot lamp.

Specifications:-

Continuous rating Input	1,300W
Impacts per minute (ipm)	1,100-2,650
Sound pressure level	90dB(A)
Sound power level	101 dB(A)
Vibration level	Chiseling: 13.5m/s ²
Dimensions (L x W x H)	528 x 115 x 247mm (20-3/4" x 4-1/2" x 9-3/4")
Net weight	7.3kg (16.2lbs)
Power supply cord	5.0m (16.4ft)

Standard Equipment: Grease for Bit, Side Handle. (Tool does not come with bull point)

HM1111C - Adapted for SDS-MAX Shank Acc Pg. A070-079 **175** 

Demolition Hammer



17  **AVT** *SOFT NOLOAD*

AVT (Anti-Vibration Technology) ensures extra-low vibration performance.

- Soft no load function ensures low vibration performance.
- High durability and excellent demolition performance.
- One touch sliding chuck for easy bit installation and removal.
- LED lamp indicates when to replace carbon brush.
- LED lamp is provided as a pilot lamp.



Specifications:- 

Continuous rating Input	1,300W
Impacts per minute	1,100-2,650 ipm
Sound pressure level	88dB(A)
Sound power level	99dB(A)
Vibration	Chiseling: 8m/s ²
Dimensions (L x W x H)	528 x 115 x 247mm (20-3/4" x 4-1/2" x 9-3/4")
Net weight	8.0kg (17.7lbs)
Power supply cord	5.0m (16.4ft)

Standard Equipment: Grease for Bit, Side Handle. (Tool does not come with bull point)

HM1201 13/16": Adapted for 21mm Hex Shank Acc Pg. A071-079 **155** 

Demolition Hammer

13 

Powerful impact from durable aluminum body

- Anti-vibration spring on rear handle for reduced operator fatigue.
- Factory grease packed for reduced maintenance.
- Automatic brush cut-out when periodic service is due.

Specifications:- 

Continuous rating Input	1,130W
Impacts per minute (ipm)	2,000
Overall length	480mm (18-7/8")
Net weight	9.1kg (20.2lbs)
Power supply cord	5.0m (16.4ft)

Standard Equipment: Bull Point, Hex Wrench, Grip.

HM1203C - Adapted for SDS-MAX Shank Acc Pg. A070-079 **175** 

Demolition Hammer



25.5 

High durability and excellent demolition performance.

- One touch sliding chuck for easy bit installation and removal.
- Electronic speed control for maximum performance.
- Bit can be set at 12 positions for convenience.
- LED lamp indicates when to replace carbon brush.



Specifications:- 

Continuous rating Input	1,510W
Impacts per minute	950 - 1,900 ipm
Sound pressure level	81dB(A)
Sound power level	95dB(A)
Vibration level	Chiseling: 16.5m/s ²
Dimensions (L x W x H)	576 x 128 x 265mm (22-3/4" x 5" x 10-3/8")
Net weight	9.7kg (21.4lbs)
Power supply cord	5.0m (16.4ft)

Standard Equipment: Bull Point, Bit Grease, Side Handle.

HM1213C - Adapted for SDS-MAX Shank Acc Pg. A070-079 **175** 

Demolition Hammer

25.5 

AVT (Anti-Vibration Technology) ensures extra-low vibration performance.

- Suppression of motor speed during no-load reduces vibration of tool body.
- One touch sliding chuck for easy bit installation and removal.
- Electronic speed control for maximum performance.
- Bit can be set at 12 positions for convenience.
- LED lamp indicates when to replace carbon brush.

Specifications:- 

Continuous rating Input	1,510W
Impacts per minute	950-1,900 ipm
Sound pressure level	75dB(A)
Sound power level	95dB(A)
Vibration level	Chiseling: 8.0m/s ²
Dimensions (L x W x H)	576 x 149 x 265mm (22-3/4" x 5-7/8" x 10-3/8")
Net weight	10.8kg (23.6lbs)
Power supply cord	5.0m (16.4ft)

Standard Equipment: Bull Point, Bit Grease, Side Handle.

- CORDLESS
- FIXING / FASTENING
- DRILLING / IMPACT DRILLING
- CONCRETE DRILLING / DEMOLITION
- CUTTING [CONCRETE/ MASONRY/ METAL]
- MULTI TOOL
- GRINDING
- SANDING / POLISHING
- SAWING
- ROUTERING / PLANING
- CLEANING
- HEAT GUN / LASERS
- PNEUMATIC TOOLS
- GARDEN TOOLS
- GENERATORS



- CORDLESS
- FIXING / FASTENING
- DRILLING / IMPACT DRILLING
- CONCRETE DRILLING / DEMOLITION
- CUTTING [CONCRETE/ MASONRY/ METAL]
- MULTI TOOL
- GRINDING
- SANDING / POLISHING
- SAWING
- ROUTERING / PLANING
- CLEANING
- HEAT GUN / LASERS
- PNEUMATIC TOOLS
- GARDEN TOOLS
- GENERATORS

HM1214C - Adapted for SDS-MAX Shank Acc Pg. A070-079 **175**

Demolition Hammer

AVT SOFT NOLOAD

26 JOULES

Comfortable operation at hammering downward.

- AVT (Anti-Vibration Technology) ensures extra-low vibration performance.
- Suppression of motor speed during no-load reduces vibration of tool body.
- Long size carbon brush for service life is extended.
- One touch sliding chuck for easy bit installation and removal.
- LED lamp indicates when to replace carbon brush.

Specifications:-

Continuous rating Input	1,510W
Impacts per minute (ipm)	950-1,900
Sound pressure level	78dB(A)
Sound power level	98dB(A)
Vibration level	Chiseling: 8m/s ²
Dimensions (L x W x H)	700 x 129 x 265mm (27-1/2" x 5-1/8" x 10-3/8")
Net weight	12.3kg (27.1lbs)
Power supply cord	5.0m (16.4ft)



Standard Equipment: Bull Point, Bit Grease, Side Handle.

HM1304 - Adapted for 30mm Hex Shank Acc Pg. A071-079 **204**

Demolition Hammer

Grease Lubrication

25.7 JOULES

Features extremely low noise and low vibration, yet with outstanding power.

- Low noise and vibration.
- Lock-on button for continuous operation.
- Ergonomic soft rubber grip.

Specifications:-

Continuous rating Input	1,500W
Impacts per minute (ipm)	1,450
Sound pressure level	80dB(A)
Sound power level	100dB(A)
Overall length	674mm (25-1/2")
Net weight	15.5kg (34.1lbs)
Power supply cord	5.0m (16.4m)

Standard Equipment: Bull Point, Grip.

HM1306 1-3/16" Adapted for 30mm Hex Shank Acc Pg. A071-079 **204**

Demolition Hammer

Oil Lubrication

28.8 JOULES



Chipping performance ensures minimum power loss even when bull point is kept pushed against concrete in chipping operation.

- High durability.
- Soft grip provides more control and less hand fatigue.
- Adjustable large side handle improves operator comfort and control.

Specifications:-

Continuous rating Input	1,510W
Impacts per minute (ipm)	1,450
Dimensions (L x W x H)	652 x 121 x 231mm (25-3/4" x 4-3/4" x 9-1/8")
Net weight	15.1kg (33.3lbs)
Power supply cord	5.0m (16.4ft)

Standard Equipment: Bull Point, Wrench, Side Handle, Oil Supply 100mL.

HM1307C 1-3/16" : Adapted for 30mm Hex Shank Acc Pg. A071-079 **175**

Demolition Hammer

33.8 JOULES



High durability and excellent demolition performance.

- Electrical speed control for maximum performance.
- LED lamp indicates when to replace carbon brush.
- LED lamp is provided as a pilot lamp.

Specifications:-

Continuous rating Input	1,510W
Impacts per minute (ipm)	730-1,450
Sound pressure level	81dB(A)
Sound power level	101dB(A)
Vibration level	Chiseling: 12.5m/s ²
Dimensions (L x W x H)	715 x 129 x 266mm (28-1/8" x 5-1/8" x 10-1/2")
Net weight	15.3kg (33.8lbs)
Power supply cord	5.0m (16.4ft)

Standard Equipment: Side Handle. (Tool does not come with bit)

HM1317C 1-3/16": Adapted for 30mm Hex Shank Acc Pg. A071-079 **175** 

Demolition Hammer



AVT (Anti-Vibration Technology) ensures extra-low vibration performance.

- Suppression of motor speed during no-load reduces vibration of tool body.
- High durability and excellent demolition performance.
- Electrical speed control for maximum performance.
- LED lamp indicates when to replace carbon brush.
- LED lamp is provided as a pilot lamp.

Specifications:-



Continuous rating Input	1,510W
Impacts per minute	730-1,450 ipm
Sound pressure level	81dB(A)
Sound power level	101dB(A)
Vibration	Chiseling: 8.5m/s ²
Dimensions	715 x 129 x 266mm
(L x W x H)	(28-1/8" x 5-1/8" x 10-1/2")
Net weight	17.0kg (37.5lbs)
Power supply cord	5.0m (16.4ft)

Standard Equipment: Side Handle. (Tool does not come with bit)

HM1801 1-1/8": Adapted for 28.6mm Hex Shank Acc Pg. A071-079 **204** 

Electric Breaker



Highest in-class demolition efficiency.

- Warning lamp indicates trouble with cord.
- Cylindrical tool holder, with high reparability, new bolt holes can be drilled when the original bolt holes are clogged with broken bolts.
- Flat surface for ownership engraving or ID number labels.
- Name plate placed in position almost free from damages and scratches.

Specifications:-



Continuous rating Input	220V: 2,000W / 127V: 1,650W
Impacts per minute (ipm)	1,100
Sound pressure level	84dB(A)
Sound power level	104dB(A)
Vibration level	14m/s ²
Dimensions (L x W x H)	824x146x633mm (32-1/2"x5-3/4"x25")
Net weight	30.0kg (66.2lbs)
Power supply cord	5.0m (16.4ft)

Standard Equipment: Hex Wrench. (Tool does not come with Bull Point)

HM1812 1-1/8" : Adapted for 28.6mm Hex shank Acc Pg. A071-079

Electric Breaker

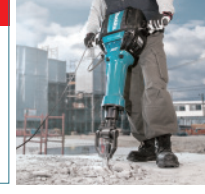

Highest-in-class demolition power with AVT (Anti-Vibration Technology)

- Counter weight mechanism and vibration absorbing housing helps to reduce vibration.
- Suppression of motor speed during no-load reduces vibration of tool body when idling.
- Soft start for suppressing start-up reaction.
- Soft grip provides more control and less hand fatigue.

The first electric breakers from Makita that are equipped with vibration absorbing housing providing a practical combination of high power and low vibration.

Soft grip

Highly durable switch

Improved reparability

Electronic control

- Soft start
- LED light to indicate energization of electric circuit
- LED light to indicate the time to replace carbon brush

Auto cut-off carbon brush

Recessed hand hold
Helps you raise a machine upright for easy transport. Located on the both sides of the machine for convenience

Vibration absorbing housing
Vibration absorbing spring (4 places)

SOFT NO LOAD AVT
ANTI VIBRATION TECHNOLOGY

Advance Vibration Control

The machine holding section is separated from the motor/transmission section

Specifications:-



Continuous rating Input	2,000W
Impact energy	72.8J
Impacts per minute (ipm)	870
Sound pressure level	96dB(A)
Sound power level	108dB(A)
Vibration level	6.5m/s ²
Dimensions (L x W x H)	843x210x608mm (33-1/4"x8-1/4"x24")
Net weight	32.2kg (70.9lbs)
Power supply cord	5.0m (16.4ft)

Standard Equipment: Bull point, Hex wrench.

CORDLESS

FIXING / FASTENING

DRILLING / IMPACT DRILLING

CONCRETE DRILLING / DEMOLITION

CUTTING [CONCRETE/ MASONRY/ METAL]

MULTI TOOL

GRINDING

SANDING / POLISHING

SAWING

ROUTERING / PLANING

CLEANING

HEAT GUN / LASERS

PNEUMATIC TOOLS

GARDEN TOOLS

GENERATORS

- CORDLESS
- FIXING / FASTENING
- DRILLING / IMPACT DRILLING
- CONCRETE DRILLING / DEMOLITION
- CUTTING [CONCRETE/ MASONRY/ METAL]
- MULTI TOOL
- GRINDING
- SANDING / POLISHING
- SAWING
- ROUTERING / PLANING
- CLEANING
- HEAT GUN / LASERS
- PNEUMATIC TOOLS
- GARDEN TOOLS
- GENERATORS

HM1802 1-1/8" : Adapted for 28.6mm Hex shank Acc Pg. A071-079

Electric Breaker



71.4 JOULES

Highest-in-class demolition power.

- Vibration absorbing housing helps to reduce vibration.
- Soft start for suppressing start-up reaction.
- Soft grip provides more control and less hand fatigue.
- Higher durability obtained by strengthening switch.
- Newly developed dust extraction attachment is available.

Specifications:-

Continuous rating Input	2,000W
Impact energy	71.4J
Impacts per minute (ipm)	870
Sound pressure level	95dB(A)
Sound power level	106dB(A)
Vibration level	14.0m/s ²
Dimensions (L x W x H)	843x210x608mm (33-1/4"x8-1/4"x24")
Net weight	30.1kg (66.4lbs)
Power supply cord	5.0m (16.4ft)

Standard Equipment: Bull point, Hex wrench.

HK0500 - Adapted for SDS-PLUS Shank Acc Pg. A071-079 **106** WATT

Power Scraper



2.8 JOULES

For scraping, chiseling and chipping.

- Bit inserts easily; just slide sleeve down to remove.
- 12 different bit angle settings.
- One touch sliding chuck with dust protection.

Specifications:-

Continuous rating Input	550W
Impacts per minute	2,000 – 3,500 ipm
Sound pressure level	83dB(A)
Sound power level	94dB(A)
Overall length	468 mm (18-7/16")
Net weight	3.2 kg (7.1 lbs)
Power supply cord	5.0 m (16.4 ft)

Standard Equipment: Scaling Chisel.

HK1810 - Makita Small Shank Acc Pg. A071-079 **106** WATT

Power Scraper



3.9 JOULES

Quick in removing tiles / concrete scales / weld spatter / old mortar.

- Barrel sheathed in rubber heat isolator.
- Factory grease packed for reduced maintenance.
- With variable speed feature.

Specifications:-

Continuous rating Input	505W
Impacts per minute	0 – 3,200 ipm
Sound pressure level	93dB(A)
Sound power level	104dB(A)
Overall length	315 mm (12-3/8")
Net weight	3.2 kg (7.1 lbs)
Power supply cord	5.0 m (16.4 ft)

Standard Equipment: Scaling Chisels x 2, Bull Point.

HK1820 - Adapted for SDS-PLUS Shank Acc Pg. A071-079 **350** WATT

Power Scraper



3.9 JOULES

Quick in removing tiles / concrete scales / weld spatter / old mortar.

- Employs SDS-Plus bit system.
- 12 bit angle settings.
- Lighter than the competing SDS-Plus power scrapers.
- Lowest-in-class vibration (10m/s²) ensures more comfort and control.
- Increased reparability of electrical parts.

Specifications:-

Continuous rating Input	550W
Impacts per minute	0 - 3,200 ipm
Sound pressure level	83dB(A)
Sound power level	94dB(A)
Vibration	10m/s ²
Dimensions (L x W x H)	351mm x 102mm x 203 mm (13-3/4" x 4" x 8")
Net weight	3.4 kg (7.5 lbs)
Power supply cord	5.0 m (16.4 ft)

Standard Equipment: Bull Point, Scaling chisel, Scaling chisel, Hook complete.

Cutting [Concrete, Masonry, Metal]

Cutter, Power Cutter, Metal Cutter, Portable Cut-Off,
Portable Band Saw, Shears and Nibblers



- CORDLESS
- FIXING / FASTENING
- DRILLING / IMPACT DRILLING
- CONCRETE DRILLING / DEMOLITION
- CUTTING (CONCRETE/ MASONRY/ METAL)
- MULTI TOOL
- GRINDING
- SANDING / POLISHING
- SAWING
- ROUTERING / PLANING
- CLEANING
- HEAT GUN / LASERS
- PNEUMATIC TOOLS
- GARDEN TOOLS
- GENERATORS

4112HS 305mm (12") Acc Pg. A105 **204**mm

Angle Cutter



305m (12") diamond wheel provides max. cutting depth of 100mm (4").

- Features soft start for smooth start-ups.
- Smooth and comfortable cutting.
- Super Joint System protects operator and gearing from accidental locking of the wheel.

Specifications:- 

Continuous rating Input	2,400W
Capacity	Max. cutting : 100mm (4")
Blade diameter	305mm (12")
No load speed	5,000rpm
Overall length	648mm (25-1/2")
Net weight	11.4kg (25.2lbs)
Power supply cord	2.5m (8.2ft)

Standard Equipment: Socket Wrench. (Tool does not come with diamond wheels)

EK6100 305mm (12") Acc Pg. A085 Acc Pg. A104-105

Power Cutter



Lightweight and compact design makes all position work easier

- Stratified scavenging system to save fuel and environment friendly.
- Long-life air filter system with cyclone air routing.
- Largest max. cutting depth and lowest vibration level in this class.
- Touch and stop switch.

Specifications:- 

Wheel diameter	305mm (12")
Engine	61mL
Max cutting depth	110mm (4-5/16")
No load speed (rpm)	5100
Circumferential speed	80m/s
Engine power	3.2kW / 4.4PS
Fuel tank	0.7L
Bore size	20mm
Vibration level Front handle	2.8m/s ²
Vibration level Rear handle	3.8m/s ²
Overall length	675mm (26-1/2")
Net weight	8.5kg (18.7lbs)

Standard Equipment: Abrasive disc, Screw driver, Universal Wrench, Hose connection, 100ml -2stroke oil

EK7301WS 350mm (14") Acc Pg. A085 Acc Pg. A104-105

Power Cutter



Powerful and compact design power cutter

- Easy and time-saving cutting even though hardest materials.
- Multi-functional switch lever : Choke, half throttle, and stopping can be controlled by a single switch lever.
- More efficient engine cooling : Obtained by using starter cover with bigger air intake area and new flywheel.
- Carburetor : Diaphragm type, Starter system : Recoil

Specifications:- 

Wheel diameter	355mm (14")
Engine	73mL
Max cutting depth	122mm (4-13/16")
Circumferential speed	80m/s
Engine power	4.2kW / 5.7PS
Fuel tank	1.1L
Bore size	25.4mm
Sound pressure level	100dB(A)
Vibration level Front handle	6.2m/s ²
Vibration level Rear handle	4.4m/s ²
Overall length	770mm (30-1/4")
Net weight	10.1kg (22.2lbs)

Standard Equipment: Water attachment kit and Abrasive wheel

EK8100WS 405mm (16") Acc Pg. A085 Acc Pg. A104-105

Power Cutter



Powerful and Lightweight power cutter in this class.

- Easy and time-saving cutting even though hardest materials.
- Multi-functional switch lever : Choke, half throttle, and stopping can be controlled by a single switch lever.
- More efficient engine cooling : Obtained by using starter cover with bigger air intake area and new flywheel.
- Carburetor : Diaphragm type, Starter system : Recoil

Specifications:- 

Wheel diameter	405mm (16")
Engine	81mL
Max cutting depth	147mm (5-3/4")
Circumferential speed	80m/s
Engine power	4.5kW / 6.2PS
Fuel tank	1.1L
Bore size	25.4mm
Overall length	830mm (32-3/4")
Net weight	10.6kg (23.3lbs)

Standard Equipment: Water attachment kit and Abrasive wheel

EK7650HX1 305mm (12") Acc Pg. A085 Acc Pg. A104-105

Power Cutter



Environment-Friendly and Cost-Saving -4Stroke Engine

- Automatic decompression Reduces start up required to pull the starter handle force by about 40% compared to 2-stroke power cutter
- Oil pre-filter cover can easily be removed without using tools
- Low-vibration system
- Castors for moving convenience
- Cutting dust suppression

Specifications:-

Wheel diameter	305mm (12")
Engine	75.6 ml
Max. cutting depth	97 (3-13/16")
Max. output power	3.0kW / 4.1PS (at 7,500 min.-1)
Max. torque	4.6 N.m (at 5,500 min.-1)
Fuel tank	1.1L
Bore size	20mm
Dimension (L x W x H)	761 x 310 x 435mm (30" x 12-1/4" x 17-1/8")
Dry weight	12.7kg (28lbs)

Standard Equipment: Engine tool set, Oil, Water supply set

EK7651HX1 355mm (14") Acc Pg. A085 Acc Pg. A104-105

Power Cutter



Environment-Friendly and Cost-Saving -4Stroke Engine

- Automatic decompression Reduces start up required to pull the starter handle force by about 40% compared to 2-stroke power cutter
- Oil pre-filter cover can easily be removed without using tools
- Low-vibration system
- Castors for moving convenience
- Cutting dust suppression

Specifications:-

Wheel diameter	355mm (14")
Engine	75.6 ml
Max. cutting depth	122mm (4-13/16")
Max. output power	3.0kW / 4.1PS (at 7,500 min.-1)
Max. torque	4.6 (at 5,500 min.-1)
Fuel tank	25.4mm
Bore size	1.1L
Dimension (L x W x H)	780 x 310 x 455mm (30-3/4" x 12-1/4" x 17-7/8")
Dry weight	12.9kg (28.4lbs)

Standard Equipment: Engine tool set, Oil, Water supply set

- CORDLESS
- FIXING / FASTENING
- DRILLING / IMPACT DRILLING
- CONCRETE DRILLING / DEMOLITION
- CUTTING [CONCRETE/ MASONRY/ METAL]
- MULTI TOOL
- GRINDING
- SANDING / POLISHING
- SAWING
- ROUTERING / PLANING
- CLEANING
- HEAT GUN / LASERS
- PNEUMATIC TOOLS
- GARDEN TOOLS
- GENERATORS

EK7650H 305mm (12") / **EK7651H** 355mm (14")



Automatic decompression
Reduces start up required to pull the starter handle force by about 40% compared to 2-stroke power cutter

Oil pre-filter
Filter cover can easily be removed without using tools

Patented leak proof fuel tank ventilation
avoids fuel leakage even when machine is tilted

Primer pump
for easy preliminary fuel feed without pulling recoil starter rope.

MM4
Makita Mini 4 stroke Engine

Cutting dust suppression

Easy belt tensioning with screwdriver

Water supply attachment

Low-vibration system
Equipped with damper springs to absorb the vibration from engine to integrated front and rear handles.

Castors for moving convenience

- CORDLESS
- FIXING / FASTENING
- DRILLING / IMPACT DRILLING
- CONCRETE DRILLING / DEMOLITION
- CUTTING [CONCRETE/ MASONRY/ METAL]**
- MULTI TOOL
- GRINDING
- SANDING / POLISHING
- SAWING
- ROUTERING / PLANING
- CLEANING
- HEAT GUN / LASERS
- PNEUMATIC TOOLS
- GARDEN TOOLS
- GENERATORS

Trolley kit (For power cutter)

A: Trolley with water attachment kit



		Type	Part no
DT2010	EK7301	A	394369600
DT4000	EK7650H / EK7651H	A	394369610
Water attachment kit	EK7301	-	394365602

Pressurised Metal Water Tank (For power cutter)

The Pressurized Water Tank makes applications like wet cutting possible in areas where water is limited or unavailable.

Portable and Easy to Operate



Max Operation Pressure:	Max water capacity	Part no
6 Bar	10 Litres	957802600

4100NH 110m (4-3/8")

Acc Pg. A100-102 **303**

Tile Cutter



More powerful cutting tile, also cut stone, masonry, concrete

- Water flow can easily be adjusted.
- Can be used with wet or dry type wheels.
- Apart from stone, masonry, tile and concrete cutting, Makita also has specialized wood cutting saw blade for cutter 4100NH



wood cutting saw blade (Optional)
(Part no: B-39475)

Specifications:-

Continuous rating Input	1,300W
Capacity	Max. cutting: 34mm (1-5/16")
Blade diameter	110mm (4-3/8")
No load speed	13,000rpm
Overall length	234mm (9-1/4")
Net weight	2.9kg (6.5lbs)
Power supply cord	2.5m (8.2ft)

Standard Equipment: Wrench, Socket Wrench, Water Plug & Tube
(Tool does not come with diamond wheel)

4107R 180mm (7-1/8")

Acc Pg. A100-102 **153**

Tile Cutter



Quick and clean cutting.

- Waterproof construction.

Specifications:-

Continuous rating Input	1,400W
Capacity	Max. cutting: 60mm (2-3/8")
Blade diameter	180mm (7-1/8")
No load speed	5,000rpm
Overall length	370mm (14-9/16")
Net weight	6.6kg (14.5lbs)
Power supply cord	5.0m (16.4ft)

Standard Equipment: Diamond Wheel, Socket Wrench, Offset Wrench, Water Plug & Tube

Clean, Compact and Comfortable Wall Chaser

Makita Wall Chaser offers the most efficient cutting of clean edged grooves for channels

SG1251 125mm (5")



SG1251J 125mm (5")

Acc Pg. A106 318

Wall Chaser



Clean, compact and comfortable.

- Ergonomically designed handle for comfort.
- Improved trigger switch - operable with the fingers of the hand holding the top handle.
- Conveniently located front cover efficiently prevents the dust from spreading, in every cutting depth.



MAKPAC - Stackable & Interlocking Tool Case

Specifications:-



Continuous rating Input	1,400W
Capacity	Depth : 0-30mm (0 - 1-3/16") Width : 6-30mm (1/4 - 1-3/16")
Blade diameter	125mm (5")
No load speed (rpm)	10,000
Dimensions (L x W x H)	350x151x178mm (13-3/4" x 5-15/16" x 7")
Net weight	4.5kg (9.8lbs)
Power supply cord	5.0m (16.4ft)

CORDLESS

FIXING / FASTENING

DRILLING / IMPACT DRILLING

CONCRETE DRILLING / DEMOLITION

CUTTING [CONCRETE/ MASONRY/ METAL]

MULTI TOOL

GRINDING

SANDING / POLISHING

SAWING

ROUTERING / PLANING

CLEANING

HEAT GUN / LASERS

PNEUMATIC TOOLS

GARDEN TOOLS

GENERATORS

SG1250 125mm (5")

Acc Pg. A106 318

Wall Chaser



Clean, compact and comfortable.

- Ergonomically designed handle for comfort.
- Conveniently located front cover efficiently prevents dust from spreading, in every cutting depth.

Specifications:-



Continuous rating Input	1,400W
Blade diameter	125mm (5")
Capacity	Depth : 0-30mm Width : 6-30mm
No load speed	9,000rpm
Overall length	346mm (13-5/8")
Net weight	4.4kg (9.7lbs)
Power supply cord	5.0m (16.4ft)

Standard Equipment: 2 pcs of Diamond Wheel, Hex Wrench, Lock Nut Wrench.

SG150 150mm (6")

Acc Pg. A106 B45872

Wall Chaser



Cuts a slot up to 35mm wide and 45mm deep in concrete with powerful 1,800W motor and double diamond wheel.

- The 1800W power and its cutting ability (from 7 to 35mm of width and from 7 to 45mm of depth) are ideal for electric main wires and spouts as well as for heating systems.

Specifications:-



Continuous rating Input	1,800W
Blade diameter	150mm (6")
Capacity	Depth: 7-45mm (9/32-1-3/4") Width: 7-35mm (9/32-1-3/8")
No load speed	7,800rpm
Overall length	410mm (16-1/8")
Net weight	5.7kg (12.6lbs)

- CORDLESS
- FIXING / FASTENING
- DRILLING / IMPACT DRILLING
- CONCRETE DRILLING / DEMOLITION
- CUTTING [CONCRETE/ MASONRY/ METAL]
- MULTI TOOL
- GRINDING
- SANDING / POLISHING
- SAWING
- ROUTERING / PLANING
- CLEANING
- HEAT GUN / LASERS
- PNEUMATIC TOOLS
- GARDEN TOOLS
- GENERATORS

4131 185mm (7-1/4")
Acc Pg. A082 **303**

Metal Cutter



185mm (7-1/4") metal cutter for cutting steel up to 6mm in thickness.

- Dust-free, high-speed cutting.
- Cuts steel with minimal burrs and burns.
- One-touch dust-box removable.

Specifications:-

Continuous rating Input	1,100W
Blade diameter	185mm (7-1/4")
Capacity	Max. cutting: 63mm (2-1/2")
No load speed	3,500rpm
Overall length	358mm (14-1/8")
Net weight	5.1kg (11.3lbs)
Power supply cord	2.5m (8.2ft)

Standard Equipment: Carbide-Tipped Saw Blade, Hex Wrench, Safety Goggles.

CA5000XJ 118mm (4-5/8")
303

Aluminum Groove Cutter



Tool be used with guide Rail



Developed for cutting grooves in aluminum composite materials

- Cutter blade for 90 degrees V shaped groove enables you to cut grooves in aluminum composite materials (e.g. exterior wall panels).
- Ideal for processing aluminum composite material
- User-friendly blade cover design for easy blade change
- Two in one; Also can be used as a plunge cut circular saw.

Specifications:-

Continuous rating input	1,300W
Blade	Type : Cutter blade / TCT saw blade
Blade Diameter	118mm
Hole Diameter	20mm
Max cutting capacity with Cutter blade	with Guide rail: 11mm (7/16")
Max cutting capacity with TCT Saw blade	with Guide rail: 36mm (1-7/16") without Guide rail: 41mm (1-5/8")
No Load Speed (RPM)	2,200-6,400
Dimensions (L x W x H)	346x250x250mm
Net weight	5.1kg (11.3lbs)
Power supply cord	2.5m (8.2ft)

Standard Equipment: Cutter blade, Plate, Hex wrench

CA5000 305mm (12")

Cutting grooves in aluminum composite materials



Guide Rail 1.4 m: **194368-5**
3.0 m: **194367-7**

Enables you to cut grooves in aluminum composite materials such as exterior wall panels.



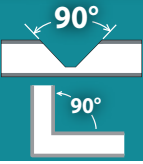

90° V shaped groove (standard accessory)



135° V shaped groove (option)





	Blade Dia (mm)	Suitable for Models	(Bore) Hole dia. (mm)	Plate (mm)	(Kerf) Tip Thickness (mm)	Hook Angle (deg)	No. of teeth	Tooth Shape	Part No.
	118	CA5000XJ	20	6	14	5	6	90°	B-48832
	118	CA5000XJ	20	6	18	5	6	135°	B-48860

2107FK Acc Pg. A084 **303**

Portable Band Saw



Large 4/3-4" x 4/3-4" capacity with excellent tool balance

- Bridge construction of aluminum frame and motor housing makes the machine more durable
- Built-in fluorescent job light for clear view of ink line even in dark places
- Switch for fluorescent job light is independent of main switch
- Preset dial for speed adjustment enables you to obtain suitable cutting speed for each material

Specifications:-

Continuous rating Input	710W
Capacity	Round work piece (dia.): 120mm (4-3/4") Rectangular work piece (Without stand): 120 x 120mm (4-3/4" x 4-3/4")
Blade speed	60m (200 ft) - 105m (350 ft) /min
Dimensions (L x W x H)	508 x 188 x 256mm (20" x 7-3/8" x 10-1/8")
Net weight	6.0kg (13.1lbs)
Power supply cord	2.5m (8.2ft)

Standard Equipment: Carbon Steel Band Saw Blade (18 teeth per inch) 1 pc, Hex. Wrench

2414 355mm (14") Acc Pg. A084 **153**

Portable Cut-off



Guide plate adjusts 45 degrees; 3 way adjustment for material holding.

- The wheel support's unique ability prevents it from loading and enhances cut-off performance.
- Quick vise for fast clamping of various size materials.

Specifications:-

Continuous rating Input	1,450W
Wheel dia.	355mm (14")
Hole dia.	25.4mm (1")
No load speed	3,800rpm
Dimensions (L x W x H)	500mm x 280mm x 600mm (19-11/16" x 11" x 23-5/8")
Net weight	16.3kg (36lbs)
Power supply cord	2.5m (8.2ft)



CUTTING CAPACITIES (mm)

○	□	▭	└
90° 45°	90° 45°	90° 45°	90° 45°
115 115	115 115	119 x 106	137 100

Standard Equipment: Abrasive Cut-off Wheel, Socket Wrench.

LC1230 305mm (12") Acc Pg. A083 **203**

Metal Cutting Saw

Fast cuts in light pipe, angle iron, tubing, conduit and channels.

- Just release lever to adjust cutting angle; no tools required.
- Carbide tipped blade lasts longer than abrasive wheel; cuts clean, accurate and virtually burr free.

Specifications:-

Continuous rating Input	1,750W
Blade diameter	305mm
Capacity	at 0 degrees: 115mm (4-1/2") at 0 degrees: 75mm x 150mm (2-15/16" x 5-7/8") at 45 degrees: 90mm (3-1/2") at 45 degrees: 85 x 85mm (3-5/16" x 3-5/16")
No load speed	1,300rpm
Dimensions (L x W x H)	516mm x 306mm x 603mm (20-1/4" x 12" x 23-3/4")
Net weight	19.3kg (42.5lbs)
Power supply cord	2.5m (8.2ft)

Standard Equipment: Carbide-tipped Saw Blade (for mild steel), Socket Wrench, Safety Goggles.

2414B 355mm (14") Acc Pg. A084 **203**

Portable Cut-off



Unique twin pivoting cutting head for increased cutting capacity.

- Quick release vise for secure stock retention and fast repeated cut-offs.
- Lock off button helps prevent accidental starting.
- Adjustable depth stop for precise, repeatable cutting depth.
- Guide plate adjusts 45 degrees, 3 way adjustment for material holding.

Specifications:-

Continuous rating Input	220V: 2,000W / 127V: 1,650W
Wheel dia.	355mm (14")
Hole dia.	25.4mm (1")
No load speed	3,800rpm
Dimensions (L x W x H)	500mm x 280mm x 600mm (19-11/16" x 11" x 23-5/8")
Net weight	15.9kg (35lbs)
Power supply cord	2.5m (8.2ft)

CUTTING CAPACITIES (mm)

○	□	▭	└
90° 45°	90° 45°	90° 45°	90° 45°
115 115	122 106	70 x 240	139 100

Standard Equipment: Abrasive Cut-Off Wheel, Socket Wrench.

- CORDLESS
- FIXING / FASTENING
- DRILLING / IMPACT DRILLING
- CONCRETE DRILLING / DEMOLITION
- CUTTING [CONCRETE / MASONRY / METAL]
- MULTI TOOL
- GRINDING
- SANDING / POLISHING
- SAWING
- ROUTERING / PLANING
- CLEANING
- HEAT GUN / LASERS
- PNEUMATIC TOOLS
- GARDEN TOOLS
- GENERATORS

- CORDLESS
- FIXING / FASTENING
- DRILLING / IMPACT DRILLING
- CONCRETE DRILLING / DEMOLITION
- CUTTING (CONCRETE/ MASONRY/ METAL)
- MULTI TOOL
- GRINDING
- SANDING / POLISHING
- SAWING
- ROUTERING / PLANING
- CLEANING
- HEAT GUN / LASERS
- PNEUMATIC TOOLS
- GARDEN TOOLS
- GENERATORS

LW1400
Acc Pg. A084 203
355mm (14")

Portable Cut-off

Powerful 2,200W motor 355mm (14") Portable Cut-off, with tool-less functions

- Replacement of Abrasive cut-off wheel and adjustment of Guide plate can be done without any tools.
- Large spark guard prevents backward scattering of spark.
- Quick release vise
- Carry handle for easy transport to job site

Toolless adjustment of guide plate allows for easy adjustment of the guide plate by simple handling

- 3 stage position change
- 0 to 45 degree angle adjustment

Change of saw head locking device from chain lock to pin lock makes it easier to lock down the saw head for storage and transport.

Shaft lock for easy replacement of abrasive cut-off wheel

Carry handle for easy transport to job site

Toolless replacement of abrasive cut-off wheel

Large spark guard

Specifications:- □

Continuous rating input	2,200W	
Wheel size	Diameter : 355mm (14")	
	Hole diameter: 25.4mm (1")	
	Thickness: 3mm (1/8")	
No load speed (rpm)	3,800	
Capacity	Round stock: 127mm (5")	
	Rectangular stock (H x W) : 102x194mm	
Dimensions (L x W x H)	530x295x640mm (20-7/8"x11-5/8"x25-1/4")	
Net weight	17.0kg (37.5lbs)	
Power supply cord	2.5m (8.2ft)	

CUTTING CAPACITIES (mm)

○	□	▭	└┐
90° 115	45° 115	90° 115	45° 115
119 x 106		137	100

Standard Equipment: Abrasive cut-off wheel, Socket wrench

LW1401
Acc Pg. A084 203
355mm (14")

Portable Cut-off

Powerful 2,200W motor 355mm (14") Portable Cut-off, successor to 2414NB

- Quick release vise.
- Carry handle for easy transport to job site.

Specifications:- □

Continuous rating input	2,200W	
Wheel size	Diameter : 355mm (14")	
	Hole diameter: 25.4mm (1")	
	Thickness: 3mm (1/8")	
No load speed (rpm)	3,800	
Capacity	Round stock: 127mm (5")	
	Rectangular stock (H x W) : 70x233mm	
Dimensions (L x W x H)	500x290x620mm (19-3/4"x11-3/8"x24-3/8")	
Net weight	16.6kg (36.6lbs)	
Power supply cord	2.5m (8.2ft)	

CUTTING CAPACITIES (mm)

○	□	▭	└┐
90° 115	45° 115	90° 115	45° 115
119 x 106		137	100

Standard Equipment: Abrasive Cut-off Wheel, Socket Wrench.

2416S
Acc Pg. A084 153
405mm (16")

Portable Cut-off

405mm (16") blade for more cutting capacity.

- Good reputation for pipe and angle iron cut-off work.
- Quick release vise for secure stock retention and fast repeated cut-offs.

Specifications:- □

Continuous rating Input	1,430W	
Wheel dia.	405mm (16")	
Hole dia.	25.4mm (1")	
No load speed	2,300rpm	
Dimensions (L x W x H)	610mm x 265mm x 535mm (24" x 10-3/8" x 21")	
Net weight	19.2kg (42.3lbs)	
Power supply cord	2.5m (8.2ft)	

CUTTING CAPACITIES (mm)

○	□	▭	└┐
90° 115	45° 115	90° 120	45° 110
80 x 230		150	110

Standard Equipment: Abrasive Cut-Off Wheel, Socket Wrench.

Shears / Nibblers



JS1601 1.6mm (16Ga) Acc Pg. A087 **459**

Straight Metal Shear



Ingenious aesthetic design provides more control and high maneuverability

- Mainly for Straight Cutting.
- Ergonomically best possible barrel grip for straight shear.
- Side blades xed more stably.
- Rear cover ergonomically tapered for easy grip.

Specifications:-

Continuous rating Input	380W
Capacity	Steel up to 400 N/mm ² :1.6mm Steel up to 600 N/mm ² :1.2mm Steel up to 800 N/mm ² :0.8mm Aluminum up to 200 N/mm ² : 2.5mm
Min. cutting radius	250mm (9-7/8")
Strokes per min.	4,500
Dimensions (L x W x H)	320x70x78mm (12-5/8"x2-3/4"x3-1/16")
Net weight	1.4kg (3.1lbs)
Power supply cord	2.5m (8.2ft)

Standard Equipment: Hex Wrench, Thickness Gauge

CORDLESS

FIXING / FASTENING

DRILLING / IMPACT DRILLING

CONCRETE DRILLING / DEMOLITION

CUTTING [CONCRETE / MASONRY / METAL]

MULTI TOOL

GRINDING

SANDING / POLISHING

SAWING

ROUTERING / PLANING

CLEANING

HEAT GUN / LASERS

PNEUMATIC TOOLS

GARDEN TOOLS

GENERATORS

JS1602 1.6mm (16Ga) Acc Pg. A087 **459**

Metal Shear



Slim motor housing and rear cover provides more control and better maneuverability.

- Conveniently located slide switch for one hand operation.
- Common blade with JS1600.

Specifications:-

Continuous rating Input	380W
Capacity	Steel up to 400 N/mm ² : 1.6mm Steel up to 600 N/mm ² : 1.2mm Steel up to 800 N/mm ² : 0.8mm Aluminum up to 200 N/mm ² : 2.5mm
Min. cutting radius	30mm (1-3/16")
Strokes per minute (spm)	4,000
Dimensions (L x W x H)	255x74x146mm (10"x2-15/16"x5-3/4")
Net weight	1.6kg (3.4lbs)
Power supply cord	2.5m (8.2ft)

Standard Equipment: Hex wrench

JS3201 3.2mm Acc Pg. A087 **303**

Metal Shear



Robust design with elastomer coated handle provides easy operation

- Protector equipped under the body prevents from scratching by metal cutting piece, and enables smooth cutting.
- Common blade with JS3200.
- On-tool storage for Hex wrench

Specifications:-



Continuous rating Input	710W
Capacity	Steel up to 400 N/mm ² : 3.2mm Steel up to 600 N/mm ² : 2.5mm Steel up to 800 N/mm ² : 1.5mm Aluminum up to 200 N/mm ² : 4.0mm
Min. cutting radius	50mm (2")
Strokes per minute (spm)	1,600
Dimensions (L x W x H)	213x90x239mm (8-3/8"x3-1/2"x9-3/8")
Net weight	3.4kg (7.4lbs)
Power supply cord	2.5m (8.2ft)

Standard Equipment: Shear blades set, Hex wrench, Thickness gauge

- CORDLESS
- FIXING / FASTENING
- DRILLING / IMPACT DRILLING
- CONCRETE DRILLING / DEMOLITION
- CUTTING [CONCRETE/ MASONRY/ METAL]
- MULTI TOOL
- GRINDING
- SANDING / POLISHING
- SAWING
- ROUTERING / PLANING
- CLEANING
- HEAT GUN / LASERS
- PNEUMATIC TOOLS
- GARDEN TOOLS
- GENERATORS

JN1601
Acc Pg. A087 411

Nibbler



Precise, burr-free curved and straight cuts from slim, yet powerful performer

- Cuts flat and corrugated sheet metal with the same die.
- Die rotates 360 degrees, large 1/4" stroke.
- Extremely light (weighs only 1.6kg).
- Built-in thickness gauge for convenience



Specifications:- □

Continuous rating Input Capacity	550W Steel up to 400 N/mm ² : 1.6mm Steel up to 600 N/mm ² : 1.2mm Steel up to 800 N/mm ² : 0.8mm Aluminum up to 200 N/mm ² : 2.5mm
Min. cutting radius	Outside edge : 50mm (2") Inside edge : 45mm (1-3/4")
Strokes per min.	2,200
Overall length	261mm (10-1/4")
Net weight	1.6kg (3.6lbs)
Power supply cord	2.0m (6.6ft)

Standard Equipment: Hex Wrench, Wrench, Punch, Die

JN3201
Acc Pg. A087 303

Nibbler

Robust design with elastomer coated handle provides easy operation.

- Common blade with JN3200
- On-tool storage for Hex wrench

Specifications:- □  **WITH MAKPAC**

Continuous rating Input Capacity	710W Steel up to 400 N/mm ² : 3.2mm Steel up to 600 N/mm ² : 2.5mm Steel up to 800 N/mm ² : 1.0mm Aluminum up to 200 N/mm ² : 3.5mm
Min. cutting radius	Outside edge: 128mm (5-1/16") Inside edge: 120mm (4-3/4")
Strokes per minute (spm)	1,300
Dimensions (L x W x H)	225x90x254mm (8-7/8"x3-1/2"x10")
Net weight	3.4kg (7.4lbs)
Power supply cord	2.5m (8.2ft)

Standard Equipment: Punch Die, Wrench 50, Hex Wrench, Washer.

Metal Shear
JS3201 3.2mm (10Ga)

Max cutting capacities:
3.2mm (10Ga)
Steel up to 400 N/mm²

Minimum. cutting radius
R= 50 mm
Steel up to 400 N/mm²(2.3) ²mm)



Nibbler
JN3201 3.2mm (10Ga)



Ø42mm
Please make a hole beforehand ø42mm

8mm
120mm
Minimum cutting radius
Outer edge: 128mm (16/1-5")
Inner edge: 120mm (4/3-4")



Multi Tool

for various Applications



Cutting PVC, FRP pipes



Sanding/polishing various materials



Scraping floor tiles



Removing mortar, tile adhesive



Routing joints on wall tiles



Corner cutting



Cutting tiles



Cutting plasterboards



Wood flush cutting



Wood plunge cutting



Deep plunge cutting



Cutting window putty, silicone



Metal flush cutting



Flush cutting of nails



Cutting polystyrene, rubber



Cutting metals



CORDLESS
FIXING / FASTENING
DRILLING / IMPACT DRILLING
CONCRETE DRILLING / DEMOLITION
CUTTING (CONCRETE/ MASONRY/ METAL)
MULTI TOOL
GRINDING
SANDING / POLISHING
SAWING
ROUTERING / PLANING
CLEANING
HEAT GUN / LASERS
PNEUMATIC TOOLS
GARDEN TOOLS
GENERATORS

DTM51 Acc Pg. A089-098

18V LXT Cordless Multi Tool



Tool-less accessory clamp for quick installation and replacement.

- 12 angle setting of accessories at every 30° from 0° to 360°.
- Variable speed control by dial.
- Battery capacity warning lamp.
- Anti-restart function prevents accidental start-up.

Specifications:-

Oscillations per minute (opm)	6,000-20,000
Dimensions (L x W x H)	326x80x122mm (12-7/8" x 3-1/8" x 4-13/16")
Net weight	2.0kg (4.4lbs)

Standard Equipment: Hex wrench.

AVAILABLE VARIANTS

5.0Ah	3.0Ah	"Z" VARIANT
DTM51 RTJ INCLUDES 2 BATTERIES / 1 CHARGER / MAKPAC CONNECTOR CASE	DTM51 RFJ INCLUDES 2 BATTERIES / 1 CHARGER / MAKPAC CONNECTOR CASE	DTM51 Z TOOL ONLY (DOES NOT INCLUDE BATTERY / CHARGER OR CARRY CASE)

TM3010CK Acc Pg. A089-098 **459**

Multi Tool



Equipped with the tool-less accessory change system.

- Wide selection of accessories available for various applications.
- Anti-restart function prevents accidental startup.
- Fully 360° multi angle setting enables users to position accessories in 12 different angles.
- Ergonomically designed rubberized grip provides more control and comfort. Variable speed control dial.

Specifications:-

Continuous rating Input	320W
Strokes per minute (spm)	6,000-20,000
Dimensions (L x W x H)	283x68x87mm (11-1/8" x 2-11/16" x 3-7/16")
Net Weight	1.6kg (3.7lbs)
Power supply cord	2.5m (8.2ft)

TM30D Acc Pg. A089-098

12V MAX CXT Cordless Multi Tool



High power, Wide selection of accessories available for various applications high cutting efficiency

- 12 angle setting of accessories at every 30° from 0° to 360°
- Ergonomically designed rubberized grip provides more control and comfort.
- Anti-restart function prevents accidental start-up.
- Variable speed control by dial

Specifications:-

Oscillations per minute (opm)	6,000-20,000
Dimensions (L x W x H)	277x65x98mm (10-7/8" x 2-9/16" x 3-7/8")
Net weight	1.1kg (2.4lbs)

Standard Equipment: Hex Wrench

AVAILABLE VARIANTS

2.0Ah	"Z" Version
TM30DWAJ INCLUDES 2 BATTERIES / 1 CHARGER / MAKPAC CASE	TM30DZ TOOL ONLY (DOES NOT INCLUDE BATTERY / CHARGER OR CARRY CASE)

CLX203AX4

12V MAX CXT COMBO KIT (Hammer drill + Multi tool)

COMBO KIT



HP331DZ Percussion Driver Drill (12VMAX Li-Ion),



TM30DZ Multi-Tool (12VMAX Li-Ion)

BL1021B 2pcs x 2.0Ah Batteries (12VMAX Li-Ion)

DC10WC 10.8V -12VMAX CXT Li-ion Charger

13pcs Oscillating Multi Tool Accessories in a plastic case (TMA007 Segment saw blade TMA009 Plunge cut saw blade Sanding pad Abrasive Delta Paper with mixed grit sizes 60, 80, 120, 180, 240.)

Tool bag

Grinders

Angle Grinder, Die Grinder, Bench Grinder,
Concrete Planer



100mm
Angle Grinder
GA4040, GA4040C,



115mm
Angle Grinder
GA4540C, GA4540



125mm
Angle Grinder
GA5040C, GA5040C



180mm
Angle Grinder
GA7063



230mm
Angle Grinder
GA9063

- CORDLESS
- FIXING / FASTENING
- DRILLING / IMPACT DRILLING
- CONCRETE DRILLING / DEMOLITION
- CUTTING [CONCRETE/ MASONRY/ METAL]
- MULTI TOOL
- GRINDING
- SANDING / POLISHING
- SAWING
- ROUTERING / PLANING
- CLEANING
- HEAT GUN / LASERS
- PNEUMATIC TOOLS
- GARDEN TOOLS
- GENERATORS



SJST

SUPER JOINT SYSTEM

To suppress vibration to operator



Structure of Super Joint System II

Leaf spring absorbs vibration and relieves shock during operation.



Absorption mechanism of vibration

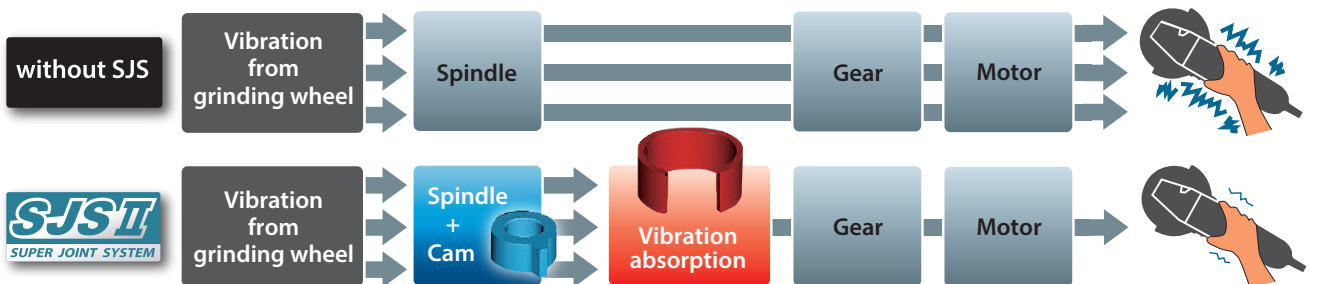

Grinder Chart

GRINDER	SIZE	POWER	NO LOAD SPEED	WEIGHT	SYSTEM	SWITCH	HANDLE	ANTI RESTART	SOFT START	CONSTANT SPEED	VARIABLE SPEED	TORQUE LIMITER
N9500N	100mm	570W	12000 rpm	1.6kg		TOGGLE						
9553HN	100mm	710W	11000 rpm	1.5kg		SLIDE						
9556HN	100mm	840W	11000 rpm	1.6kg		SLIDE						
9556HP	100mm	840W	11000 rpm	1.7kg		PADDLE						
GA4040Z	100m	1,100W	11000 rpm	2.2kg	SJSII	SLIDE						
GA4050	100m	1,300W	11000 rpm	2.3kg		PADDLE						
GA4050R	100m	1,300W	11000 rpm	2.3kg		PADDLE		•	•			
GA4040CZ	100mm	1,400W	2,800-11,000 rpm	2.3kg	SJSII	SLIDE		•	•	•	•	
9521NB	115mm	670	12000 rpm	01.3kg		SLIDE						
9554HN	115mm	710W	10000 rpm	1.6kg		SLIDE						
9557HN	115mm	840W	11000 rpm	1.7kg		SLIDE						
9557HP	115mm	840W	11000 rpm	1.7kg		PADDLE						
GA4540Z	115mm	1,100W	11000 rpm	2.3kg	SSII	SLIDE						
9564PZ	115mm	1,100W	12000 rpm	2.4kg	SJS	PADDLE						
GA4550	115mm	1,300W	11000 rpm	2.4kg		PADDLE						
GA4550R	115mm	1,300W	11000 rpm	2.4kg		PADDLE		•	•			
GA4540CZ	115mm	1,400W	2,800-11,000 rpm	2.4kg	SJSII	SLIDE		•	•	•	•	
9564PC	115mm	1,400W	12000 rpm	2.4kg	SJS	PADDLE				•		
9522NB	125mm	670W	9500 rpm	1.3kg		SLIDE						
9555HN	125mm	710W	11000 rpm	1.6kg		SLIDE						
9558HN	125mm	840W	11000 rpm	1.8kg		SLIDE						
9558HP	125mm	840W	11000 rpm	1.8kg		PADDLE						
9015B	125mm	1,050	10000 rpm	2.4kg		LARGE TRIGGER						
GA5010	125mm	1,050	12000 rpm	1.6kg		FINGER TRIGGER						
GA5040Z	125mm	1,100W	11000 rpm	2.4kg	SJSII	SLIDE						
9565PZ	125mm	1,100W	12000 rpm	2.4kg	SJS	PADDLE						
GA5050	125mm	1,300W	11000 rpm	2.5kg		PADDLE						
GA5050R	125mm	1,300W	11000 rpm	2.5kg		PADDLE		•	•			
GA5040CZ	125mm	1,400W	2,800-11,000 rpm	2.5kg	SJSII	SLIDE		•	•	•	•	
9565PC	125mm	1,400W	12000 rpm	2.4kg	SJS	PADDLE				•		
GA6010	150mm	1,050W	10000 rpm	2.7kg		FINGER TRIGGER						
GA7050	180mm	2,000W	8500 rpm	4.0kg		LARGE TRIGGER						
GA7020	180mm	2,200W	8500 rpm	5.6kg		LARGE TRIGGER						
GA7062	180mm	2,200W	8500 rpm	5.5kg		LARGE TRIGGER	D SHAPE					
GA7063	180mm	2,200W	8500 rpm	5.6kg	SJSII	LARGE TRIGGER	D SHAPE					
GA7030	180mm	2,400W	8500 rpm	6.0kg		LARGE TRIGGER						•
GA7040S	180mm	2,600W	8500 rpm	6.4kg		LARGE TRIGGER			•			•
GA9050	230mm	2,000W	6600 rpm	4.7kg		LARGE TRIGGER						
GA9050R	230mm	2,000W	6600 rpm	4.9kg		LARGE TRIGGER		•	•			
GA9020	230mm	2,200W	6000 rpm	5.8kg		LARGE TRIGGER						
GA9062	230mm	2,200W	6600 rpm	5.7kg		LARGE TRIGGER	D SHAPE					
GA9063	230mm	2,200W	6600 rpm	5.8kg	SJSII	LARGE TRIGGER	D SHAPE					
GA9030	230mm	2,400W	6600 rpm	6.3kg		LARGE TRIGGER						•
GA9040S	230mm	2,600W	6600 rpm	6.7kg		LARGE TRIGGER			•			•

CORDLESS

FIXING /
FASTENINGDRILLING /
IMPACT DRILLINGCONCRETE DRILLING /
DEMOLITIONCUTTING
[CONCRETE / MASONRY/
METAL]

MULTI TOOL

GRINDING

SANDING /
POLISHING

SAWING

ROUTERING /
PLANING

CLEANING

HEAT GUN / LASERS

PNEUMATIC TOOLS

GARDEN TOOLS

GENERATORS

- CORDLESS
- FIXING / FASTENING
- DRILLING / IMPACT DRILLING
- CONCRETE DRILLING / DEMOLITION
- CUTTING (CONCRETE/ MASONRY/ METAL)



Angle Grinder - 570W (Toggle Switch) Acc Pg. A099-128 411

N9500N 100mm (4")

Continuous rating Input	570W
Capacity	Depressed center wheel: 100mm (4") Wire cup brush: 75mm (3") Cut-off wheel: 110mm (4-3/8")
No load speed	Abrasive disc: 100mm (4")
Dimensions (L x W x H)	245mm (9-5/8")
Spindle thread	M10 x 1.25
Net weight	1.6kg (3.5lbs)
Power supply cord	2.5m (8.2ft)

Durable Aluminium Body

- 12,000rpm for fast and efficient work.
- Switch is located on tail.
- Can be used with grinding wheel or optional diamond wheel.
- Externally accessible carbon brushes for fast and easy replacement.

Standard Equipment: Lock Nut Wrench, Grip.

- MULTI TOOL
- GRINDING
- SANDING / POLISHING
- SAWING
- ROUTERING / PLANING

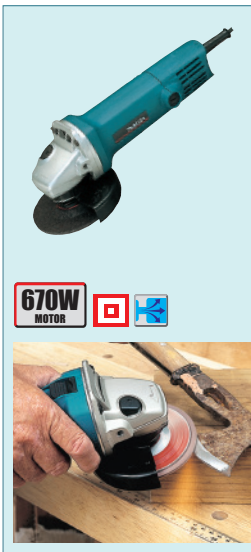

Angle Grinder - 670W (Toggle Switch) Acc Pg. A099-128 411

9520B 100mm (4")

Continuous rating Input	670 W
Capacity	Depressed center wheel: 100 mm (4") Wire cup brush: 75 mm (3") Abrasive Disc: 100 mm (4") Diamond wheel: 110 mm (4-3/8")
No load speed	12,000 rpm
Dimensions (L x W x H)	259 mm (10-3/16")
Spindle thread	M10 x 1.5
Net weight	1.3 kg (2.9 lbs)
Power supply cord	2.5 m (8.2 ft)

Incredibly light, yet powerful one-hand grinder with slender barrel grip and reduced noise.

- Powerful grinding from an amazingly slim and trim angle grinder.

Standard Equipment: Lock Nut Wrench, Grip.

- CLEANING
- HEAT GUN / LASERS
- PNEUMATIC TOOLS
- GARDEN TOOLS
- GENERATORS



Angle Grinder - 670W (Slide Switch) Acc Pg. A099-128 411

	9521NB 115mm (4-1/2")	9522NB 125mm (5")
Continuous rating Input	670 W	670 W
Capacity	Depressed center wheel: 115 mm (4 – 1/2") Abrasive disc: 115 mm (4 – 1/2") Diamond wheel: 115 mm (4 – 1/2")	Depressed center wheel: 125 mm (5") Abrasive disc: 125 mm (5") Diamond wheel: 125 mm (5")
No load speed	12,000rpm	9,500 rpm
Dimensions	262mm (10 – 3/8")	262 mm (10-3/8")
Spindle thread	DIN type	DIN type
Net weight	1.3 kg (2.8 lbs)	1.3 kg (2.9 lbs)
Power supply cord	2.5 m (8.2 ft)	2.5 m (8.2 ft)

Compact and easy to grip

- Incredibly light but powerful one-hand grinder with slimmer grip and less noise.

Standard Equipment: Lock Nut Wrench, Grip.



Angle Grinder - 710W (Slide Switch)

Acc Pg. A099-128 **325**

	9553HN 100mm (4")	9554HN 115mm (4-1/2")	9555HN 125mm (5")
Continuous rating input	710W	710W	710W
Wheel Diameter	100 mm (4")	115 mm (4-1/2")	125 mm (5")
No Load Speed (RPM)	11,000	10,000	10,000
Vibration Level	-	Surface Grinding: 7.0 m/s ² Disc Sanding: 2.5 m/s ² or less	Surface Grinding: 8.5 m/s ² Disc Sanding: 2.5 m/s ² or less
Sound Pressure Level	-	85 dB(A)	85 dB(A)
Sound Power Level	-	96 dB(A)	96 dB(A)
Dimensions (L x W x H)	258x118x97 mm (10-1/8"x4-5/8"x3-13/16")	258x129x106 mm (10-1/8"x5-1/8"x4-3/16")	258x139x106 mm (10-1/8"x5-1/2"x4-3/16")
Net weight	1.5 kg (3.2 lbs)	1.6 kg (3.5 lbs)	1.6 kg (3.5 lbs)
Power supply cord	2.5 m (8.2 ft.)	2.5 m (8.2 ft.)	2.5 m (8.2 ft.)

Compact yet powerful one-hand grinder.

- Small circumference barrel grip for easy handling.
- Labyrinth construction prevents all ball bearings from dust and debris.
- Armature coated with protective zig zag varnish and field coated with powder varnish to protect the motor from dust and wire breakage, ensuring durability enough for masonry cutting.

Standard Equipment: Lock Nut Wrench, Grip.

710W
MOTOR



CORDLESS

FIXING /
FASTENINGDRILLING /
IMPACT DRILLINGCONCRETE DRILLING /
DEMOLITIONCUTTING
[CONCRETE/ MASONRY/
METAL]

MULTI TOOL

GRINDING

SANDING /
POLISHING

SAWING

ROUTERING /
PLANING

CLEANING

HEAT GUN / LASERS

PNEUMATIC TOOLS

GARDEN TOOLS

GENERATORS



Angle Grinder - 720W (Slide Switch)

Acc Pg. A099-128 **459**

	GA4030 100mm (4")	GA4530 115mm (4-1/2")	GA5030 125mm (5")
Continuous rating input	720W	720W	720W
Wheel Diameter	100 mm (4")	115 mm (4-1/2")	125 mm (5")
No Load Speed (RPM)	11,000	11,000	11,000
Vibration Level	Surface Grinding: 7.0 m/s ² Disc Sanding: 2.5 m/s ² or less	Surface Grinding: 7.5 m/s ² Disc Sanding: 2.5 m/s ²	Surface Grinding: 8.5 m/s ² Disc Sanding: 2.5 m/s ² or less
Sound Pressure Level	85 dB(A)	85 dB(A)	85 dB(A)
Sound Power Level	96 dB(A)	96 dB(A)	96 dB(A)
Dimensions (L x W x H)	266x117x95 mm (10-1/2"x4-5/8"x3-3/4")	266x128x103 mm (10-1/2"x5"x4-1/16")	266x140x108 mm (10-1/2"x5-1/2"x4-1/4")
Net weight	2.0 kg	2.2 kg	3.0 kg
Power supply cord	2.5 m (8.2 ft.)	2.5 m (8.2 ft.)	2.5 m (8.2 ft.)

Small circumference barrel grip and ergonomically designed side grip angle for easy handling.

- Labyrinth construction protects all ball bearings from dust and debris.
- High quality motor with excellent heat-resistance.
- Small gear housing provides easy handling and high maneuverability.
- Motor field coated with protective powder varnish to protect from dust.

Standard Equipment: Lock Nut Wrench, Grip.

720W
MOTOR



Dead Man Switch



Angle Grinder - 720W (Paddle Switch)

Acc Pg. A099-128 **459**

	GA4034 100mm (4")	GA5034 125mm (5")
Continuous rating input	720W	720W
Wheel Diameter	100 mm (4")	125 mm (5")
No Load Speed (RPM)	11,000	11,000
Vibration Level	Surface Grinding: 7.0 m/s ² Disc Sanding: 2.5 m/s ² or less	Surface Grinding: 8.0 m/s ² Disc Sanding: 2.5 m/s ² or less
Sound Pressure Level	85 dB(A)	86 dB(A)
Sound Power Level	96 dB(A)	97 dB(A)
Dimensions (L x W x H)	266x117x95 mm (10-1/2"x4-5/8"x3-3/4")	265x139x103 mm (10-3/8"x5-1/2"x4-1/16")
Net weight	2.0 kg	3.15 kg
Power supply cord	2.5 m (8.2 ft.)	2.5 m (8.2 ft.)

Easy to operate paddle switch by the hand gripping motor housing.

- Small circumference barrel grip and ergonomically designed side grip angle for easy handling.
- Labyrinth construction protects all ball bearings from dust and debris.
- High quality motor with excellent heat-resistance.
- Small gear housing provides easy handling and high maneuverability.
- Motor field coated with protective powder varnish to protect from dust.

Standard Equipment: Lock Nut Wrench, Grip.

720W
MOTOR



- CORDLESS
- FIXING / FASTENING
- DRILLING / IMPACT DRILLING
- CONCRETE DRILLING / DEMOLITION
- CUTTING (CONCRETE/ MASONRY/ METAL)

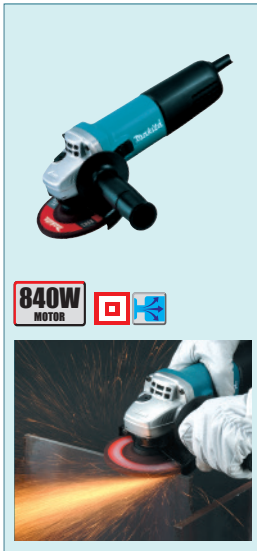

Angle Grinder - 840W (Slide Switch)

Acc Pg. A099-128 **325**

	9556HN 100mm (4")	9557HN 115mm (4-1/2")	9558HN 125mm (5")
--	-------------------	-----------------------	-------------------

Continuous rating Input	840W	840W	840W
Capacity	Depressed center wheel: 100mm (4") Abrasive disc: 100mm (4") Diamond wheel: 100mm (4")	Depressed center wheel: 115mm (4-1/2") Abrasive disc: 115mm (4-1/2") Diamond wheel: 115mm (4-1/2")	Depressed center wheel: 125mm (5") Abrasive disc: 125mm (5") Diamond wheel: 125mm (5")
No load speed	11,000rpm	11,000rpm	11,000rpm
Dimensions (L x W x H)	271mm x 129mm x 106mm (10-5/8" x 5-1/8" x 4-3/16")	271mm x 129mm x 106mm (10-5/8" x 5-1/8" x 4-3/16")	271mm x 139mm x 106mm (10-5/8" x 5-1/2" x 4-3/16")
Spindle thread	DIN type	DIN type	DIN type
Net weight	2.0kg (4.4lbs)	2.0kg (4.4lbs)	2.1kg (4.6lbs)
Power supply cord	2.5m (8.2ft)	2.5m (8.2ft)	2.5m (8.2ft)



High performance motor and high heat resistance.

- Labyrinth construction protects all ball bearings from dust and debris.
- Small circumference barrel grip for easy handling.
- Shaft lock for easy wheel changes.
- Easier repairing of gear section assembled with key.

Standard Equipment: Lock Nut Wrench, Grip.

- MULTI TOOL
- GRINDING
- SANDING / POLISHING
- SAWING
- ROUTERING / PLANING

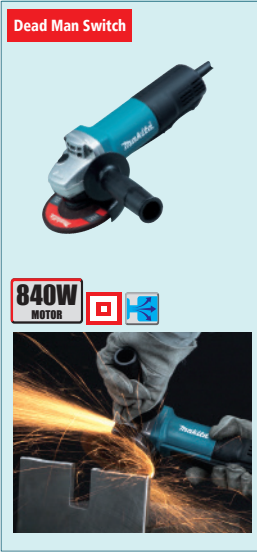

Dead Man Switch

Angle Grinder - 840W (Paddle Switch)

Acc Pg. A099-128 **325**

	9556HP 100mm (4")	9557HP 115mm (4-1/2")	9558HP 125mm (5")
--	-------------------	-----------------------	-------------------

Continuous rating Input	840W	840W	840W
Capacity	Depressed center wheel: 100mm (4") Abrasive disc: 100mm (4") Diamond wheel: 100mm (4")	Depressed center wheel: 115mm (4-1/2") Abrasive disc: 115mm (4-1/2") Diamond wheel: 115mm (4-1/2")	Depressed center wheel: 125mm (5") Abrasive disc: 125mm (5") Diamond wheel: 125mm (5")
No load speed	11,000rpm	11,000rpm	11,000rpm
Dimensions (L x W x H)	273mm x 129mm x 106mm (10-3/4" x 5-1/8" x 4-3/16")	273mm x 129mm x 106mm (10-3/4" x 5-1/8" x 4-3/16")	273mm x 129mm x 106mm (10-3/4" x 5-1/8" x 4-3/16")
Spindle thread	DIN type	DIN type	DIN type
Net weight	2.1kg (4.5lbs)	2.1kg (4.5lbs)	2.1kg (4.5lbs)
Power supply cord	2.5m (8.2ft)	2.5m (8.2ft)	2.5m (8.2ft)



Ergonomic paddle switch featured.

- Natural fit slim body to left and right hand for easy handling.
- Ergonomically designed paddle lever gives comfort to the fingers.
- Lock-off button built in the center of paddle lever.

Standard Equipment: Lock Nut Wrench, Grip.

- CLEANING
- HEAT GUN / LASERS
- PNEUMATIC TOOLS
- GARDEN TOOLS
- GENERATORS



Angle Grinder - 1,050W (Large Trigger Switch)

Acc Pg. A099-128 **303**

	9015B 125mm (5")
--	------------------

Continuous rating Input	1,050W
Capacity	Depressed center wheel: 125mm (5") Wire cup brush: 90mm (3-1/2") Abrasive disc: 125mm (5")
No load speed	Diamond wheel : 125mm (5")
Dimensions (L x W x H)	10,000rpm 381mm (15")
Spindle thread	DIN type, 5/8"-11UNC
Net weight	2.4kg (5.3lbs)
Power supply cord	2.5m (8.2ft)



Big trigger switch for convenient operation.

- Gear housing can be positioned at every 90 degrees.

Standard Equipment: Lock Nut Wrench, Grip.



1050W MOTOR

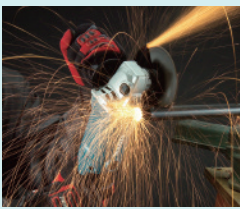

Angle Grinder - 1,050W (Finger Trigger Switch)

Acc Pg. A099-128 **303**

	GA5010 125mm (5")	GA6010 150mm (6")
Continuous rating input	1,050W	1,050W
Wheel Diameter	125 mm (5")	150 mm (6")
No Load Speed (RPM)	12,000	10,000
Vibration Level	Surface Grinding: 9.5 m/s ² Disc Sanding: 2.5 m/s ² or less	Surface Grinding: 9.5 m/s ² Disc Sanding: 2.5 m/s ²
Sound Pressure Level	89 dB(A)	90 dB(A)
Sound Power Level	100 dB(A)	101 dB(A)
Dimensions (L x W x H)	356x139x112 mm (14"x5-1/2"x4-3/8")	356x169x112 mm (14"x6-5/8"x4-3/8")
Net weight	2.6 kg (5.8 lbs)	2.7 kg (5.9 lbs)
Power supply cord	2.5 m (8.2 ft)	2.5 m (8.2 ft)

Slim body and high durability.

- Switch with easy-to-operate single-finger trigger.
- Lightweight at only 2.6kg.
- High dust-proof construction.
- Ergonomically designed handle with rubberized grip provides more control and comfort.

Standard Equipment: Lock Nut Wrench, Grip.

CORDLESS

FIXING / FASTENING

DRILLING / IMPACT DRILLING

CONCRETE DRILLING / DEMOLITION

CUTTING [CONCRETE / MASONRY / METAL]

MULTI TOOL

GRINDING

SANDING / POLISHING

SAWING

ROUTERING / PLANING

CLEANING

HEAT GUN / LASERS

PNEUMATIC TOOLS

GARDEN TOOLS

GENERATORS



1050W MOTOR



Angle Grinder - 1,050W (Large Trigger Switch)

Acc Pg. A099-128 **303**

	GA5011 125mm (5")
Continuous rating input	1,050W
Wheel Diameter	125 mm (5")
No Load Speed (RPM)	12,000
Vibration Level	Surface Grinding: 13.5 m/s ²
Sound Pressure Level	90 dB(A)
Sound Power Level	101 dB(A)
Dimensions (L x W x H)	384x139x113 mm (15-1/8"x5-1/2"x4-7/16")
Net weight	2.6kg (5.8lbs)
Power supply cord	2.5 m (8.2 ft)

Large trigger switch is easy to operate with gloved hand

- High dust-proof construction
- Rubberized soft grip for more comfort and control

Standard Equipment: Lock Nut Wrench, Grip.

SUPER JOINT SYSTEM SJS



1,100W MOTOR



Angle Grinder - 1,100W (Slide Switch) (SJS)

Acc Pg. A099-128 **325**

	9563HZ 100mm (4")	9565HZ 125mm (5")
Continuous rating input	1,100W	1,100W
Wheel Diameter	100 mm (4")	125 mm (5")
No Load Speed (RPM)	12,000	12,000
Vibration Level	Surface Grinding: 5.5 m/s ² Anti-Vibration Side Grip: 7.5 m/s ² Disc Sanding: 2.5 m/s ² or less	Surface Grinding with Anti-Vibration Side Grip: 7.5 m/s ² Disc Sanding: 2.5 m/s ² or less
Sound Pressure Level	85 dB(A)	84 dB(A)
Sound Power Level	96 dB(A)	95 dB(A)
Dimensions (L x W x H)	299x120x103 mm (11-3/4"x4-3/4"x4")	299x139x103 mm (11-3/4"x5-1/2"x4")
Net weight	2.1 kg (4.6 lbs.)	2.3 kg (5.1 lbs)
Power supply cord	2.5 m (8.2 ft)	2.5 m (8.2 ft)

High 1,100W power anti-dust motor.

- Super Joint System absorbs shock caused by accidental wheel lock and protects gears.
- Housing shape is easy to grip because of internal Brush Holders.
- Labyrinth construction seals motor and bearings from contamination.

Standard Equipment: Lock Nut Wrench, Grip.

- CORDLESS
- FIXING / FASTENING
- DRILLING / IMPACT DRILLING
- CONCRETE DRILLING / DEMOLITION
- CUTTING (CONCRETE/ MASONRY/ METAL)



Angle Grinder - 1,100W (Slide Switch) (SJS II) Acc Pg. A099-128 **325**

	GA4040Z 100mm (4")	GA4540Z 115mm (4-1/2")	GA5040Z 125mm (5")
--	--------------------	------------------------	--------------------

Continuous rating input	1,100W	1,100W	1,100W
Wheel Diameter	100 mm (4")	115 mm (4-1/2")	125 mm (5")
No Load Speed (RPM)	11,000	11,000	11,000
Vibration Level	Surface Grinding : 5.5 m/s ² Disc Sanding with Anti-Vibration Side Grip: 2.5 m/s ² or less	Surface Grinding : 6.0 m/s ² Disc Sanding with Anti-Vibration Side Grip: 2.5 m/s ² or less	Surface Grinding : 6.0 m/s ² Disc Sanding with Anti-Vibration Side Grip: 2.5 m/s ² or less
Sound Pressure Level	86 dB(A)	86 dB(A)	86 dB(A)
Sound Power Level	97 dB(A)	97 dB(A)	97 dB(A)
Dimensions	303x117x111 mm	303x130x116 mm	303x140x116 mm
(L x W x H)	(11-7/8" x 4-5/8" x 4-3/8")	(11-7/8" x 5-1/8" x 4-9/16")	(11-7/8" x 5-1/2" x 4-9/16")
Net weight	2.2 - kg (4.9 lbs)	2.3 kg (5.2 lbs)	2.4 (5.2 lbs)
Power supply cord	2.5 m (8.2 ft)	2.5 m (8.2 ft)	2.5 m (8.2 ft)

"Super Joint System II" developed for effective vibration absorption.

- Re-designed durable gear housing.
- Ergonomically best possible barrel grip.

Standard Equipment: Lock Nut Wrench, Grip.

- MULTI TOOL
- GRINDING
- SANDING / POLISHING
- SAWING
- ROUTERING / PLANING

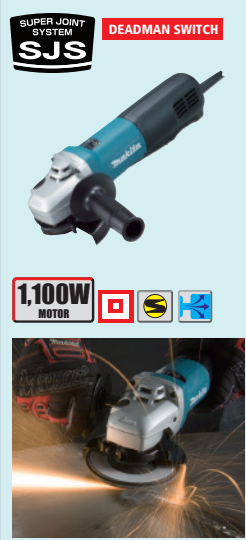

Angle Grinder - 1,100W (Paddle Switch) (SJS) Acc Pg. A099-128 **325**

	9564PZ 115mm (4-1/2")	9565PZ 125mm (5")
--	-----------------------	-------------------

Continuous rating input	1,100W	1,100W
Wheel Diameter	115 mm (4-1/2")	125 mm (5")
No Load Speed (RPM)	12,000	12,000
Vibration Level	Surface Grinding: 9.5 m/s ² Disc Sanding: 2.5 m/s ² or less	Surface Grinding: 9.5 m/s ² Disc Sanding: 2.5 m/s ² or less
Sound Pressure Level	85 dB(A)	85 dB(A)
Sound Power Level	96 dB(A)	96 dB(A)
Dimensions	307x129x103 mm	307x139x103 mm
(L x W x H)	(12-1/8" x 5-1/8" x 4")	(12-1/8" x 5-1/2" x 4")
Net weight	2.4 kg (5.3 lbs)	2.4 kg (5.3 lbs)
Power supply cord	2.5 m (8.2 ft)	2.5 m (8.2 ft)

Easy-to-operate paddle type on/off switch.

- Super Joint System absorbs shock caused by accidental wheel lock and protects gears.
- More durable gears and bearings.
- Electronic limiter & Electronic Controller.

Standard Equipment: Lock Nut Wrench, Grip.

- CLEANING
- HEAT GUN / LASERS
- PNEUMATIC TOOLS
- GARDEN TOOLS
- GENERATORS

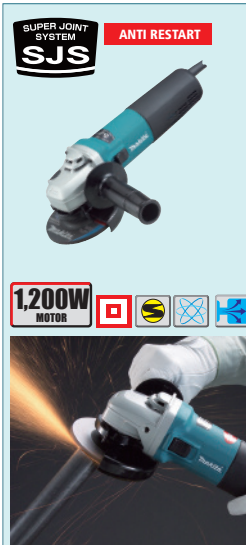

Angle Grinder - 1,200W (Slide Switch) (Anti Restart) (SJS) Acc Pg. A099-128 **318**

	9561CR 115mm (4-1/2")	9562CR 125mm (5")
--	-----------------------	-------------------

Continuous rating input	1,200W	1,200W
Wheel Diameter	115 mm (4-1/2")	125 mm (5")
No Load Speed (RPM)	12,000	12,000
Vibration Level	Surface Grinding with Anti-Vibration Side Grip: 7.5 m/s ² Disc Sanding: 2.5 m/s ² or less	Surface Grinding with Anti-Vibration Side Grip: 7.5 m/s ² Disc Sanding: 2.5 m/s ² or less
Sound Pressure Level	83 dB(A)	83 dB(A)
Sound Power Level	94 dB(A)	94 dB(A)
Dimensions	289x129x103 mm	289x139x103 mm
(L x W x H)	(11-3/8" x 5-1/8" x 4-1/16")	(11-3/8" x 5-1/2" x 4-1/16")
Net weight	2.2 kg (5.0 lbs)	2.2 kg (5.0 lbs)
Power supply cord	2.5 m (8.2 ft)	2.5 m (8.2 ft)

High 1,200W power anti-dust motor.

- Super Joint System absorbs shock caused by accidental wheel lock and protects gears.
- Labyrinth construction protects motor and bearings from dirt/dust.
- Motor Protection from overload by Electronic Limiter.
- Anti-restart function.



Standard Equipment: Lock Nut Wrench, Grip.

DEADMAN SWITCH

NEW



1,300W MOTOR

Angle Grinder - 1,300W (Paddle Switch)

Acc Pg. A099-128 **260** 

	GA4050 100mm (4")	GA4550 115mm (4-1/2")	GA5050 125mm (5")
Continuous rating input	1,300W	1,300W	1,300W
Wheel Diameter	100 mm (4")	115 mm (4-1/2")	125 mm (5")
No Load Speed (RPM)	11,000	11,000	11,000
Vibration Level	Surface Grinding: 6.5 m/s ² Disc Sanding: 2.5 m/s ² or less	Surface Grinding: 7.0 m/s ² Disc Sanding: 2.5 m/s ²	Surface Grinding: 7.5 m/s ² Disc Sanding: 2.5 m/s ² or less
Sound Pressure Level	91 dB(A)	91 dB(A)	91 dB(A)
Sound Power Level	102 dB(A)	102 dB(A)	102 dB(A)
Dimensions (L x W x H)	325x117x110 mm (12-3/4"x4-5/8"x4-5/16")	325x130x117 mm (12-3/4"x5-1/8"x4-5/8")	325x140x117 mm (12-3/4"x5-1/2"x4-5/8")
Net weight	2.6 kg	2.8 kg	2.8 kg
Power supply cord	5 m (8.2 ft.)	2.5 m (8.2 ft.)	2.5 m

Powerful 1,300 W Motor with Paddle Switch Trigger

- Enhanced shaft locking mechanism
- Toolless wheel cover - allows for fast and easy angle adjustment and installation/ removal of wheel cover
- Anti-drop holders allows to attach anti-drop strap, etc.
- Easy-to-hold barrel grip provides less hand fatigue and more control of the machine (Grip circumference smaller than 9564P series)

Standard Equipment: Lock Nut Wrench, Grip.

CORDLESS

FIXING / FASTENING

DRILLING / IMPACT DRILLING

CONCRETE DRILLING / DEMOLITION

CUTTING [CONCRETE / MASONRY / METAL]

MULTI TOOL

GRINDING

SANDING / POLISHING

SAWING

ROUTERING / PLANING

CLEANING

HEAT GUN / LASERS

PNEUMATIC TOOLS

GARDEN TOOLS

GENERATORS



ANTI RESTART

DEADMAN SWITCH

NEW



1,300W MOTOR

Angle Grinder - 1,300W (Paddle Switch) (Anti-Restart Function)

Acc Pg. A099-128 **260** 

	GA4550R 115mm (4-1/2")	GA5050R 125mm (5")
Continuous rating input	1,300W	1,300W
Wheel Diameter	115 mm (4-1/2")	125 mm (5")
No Load Speed (RPM)	11,000	11,000
Vibration Level	Surface Grinding: 7.0 m/s ² Disc Sanding: 2.5 m/s ²	Surface Grinding: 7.5 m/s ² Disc Sanding: 2.5 m/s ² or less
Sound Pressure Level	91 dB(A)	91 dB(A)
Sound Power Level	102 dB(A)	102 dB(A)
Dimensions (L x W x H)	325x130x117 mm (12-3/4"x5-1/8"x4-5/8")	325x140x117 mm (12-3/4"x5-1/2"x4-5/8")
Net weight	2.8 kg	2.8 kg
Power supply cord	2.5 m (8.2 ft.)	2.5 m

Powerful 1,300 W Motor with Paddle Switch Trigger, Anti Restart and Soft Start

- Enhanced shaft locking mechanism
- Toolless wheel cover - allows for fast and easy angle adjustment and installation/ removal of wheel cover
- Anti-drop holders allows to attach anti-drop strap, etc.
- Easy-to-hold barrel grip provides less hand fatigue and more control of the machine (Grip circumference smaller than 9564P series)



Standard Equipment: Lock Nut Wrench, Grip.

SJST **ANTI RESTART**

SUPER JOINT SYSTEM



1,400W MOTOR

Angle Grinder - 1,400W (Slide Switch) (SJS II) (Anti-Restart Function)

Acc Pg. A099-128 **318** 

	GA4040CZ 100mm (4")	GA4540CZ 115mm (4-1/2")	GA5040CZ 125mm (5")
Continuous rating input	1,400W	1,400W	1,400W
Wheel Diameter	100 mm (4")	115 mm (4-1/2")	125 mm (5")
No Load Speed (RPM)	2,800-11,000	2,800 - 11,000	2,800-11,000
Vibration Level	Surface Grinding : 5.0 m/s ² Disc Sanding : 2.5 m/s ² or less	Surface Grinding : 5.5 m/s ² Disc Sanding : 2.5 m/s ²	Surface Grinding : 5.5 m/s ² Disc Sanding : 2.5 m/s ²
Sound Pressure Level	86 dB(A)	86 dB(A)	86 dB(A)
Sound Power Level	97 dB(A)	97 dB(A)	97 dB(A)
Dimensions (L x W x H)	303x117x111 mm (11-7/8"x4-5/8"x4-3/8")	303x130x116 mm (11-7/8"x5-1/8"x4-9/16")	303x140x116 mm (11-7/8"x5-1/2"x4-9/16")
Net weight	2.3 kg (5.1 lbs)	2.4 kg (5.4 lbs)	2.5 kg (5.6 lbs)
Power supply cord	2.5 m (8.2 ft)	2.5 m (8.2 ft)	2.5 m (8.2 ft)

"Super Joint System II" developed for effective vibration absorption.

- Electronic current limiter, speed control and soft start.
- Anti-restart function.
- Re-designed durable gear housing.
- Ergonomically best possible barrel grip.

Standard Equipment: Lock Nut Wrench, Grip.

- CORDLESS
- FIXING / FASTENING
- DRILLING / IMPACT DRILLING
- CONCRETE DRILLING / DEMOLITION
- CUTTING [CONCRETE/ MASONRY/ METAL]



Angle Grinder - 1,400W (Paddle Switch) (SJS) Acc Pg. A099-128 **318**

9564PC 115mm (4-1/2")

Continuous rating input	1,400W
Wheel Diameter	115 mm (4-1/2")
No Load Speed (RPM)	12,000
Vibration Level	Surface Grinding: 10 m/s ² -
Sound Pressure Level	81 dB(A)
Sound Power Level	92 dB(A)
Dimensions (L x W x H)	307x129x103 mm (12-1/8"x5-1/8"x4")
Net weight	2.4 kg (5.3 lbs)
Power supply cord	2.5 m (8.2 ft)

High 1,400W power anti-dust motor in small circumference barrel grip body.

- Super Joint System absorbs shock caused by accidental wheel lock and protects gears.
- Automatic brush cut-off.
- Labyrinth construction, seals motor and bearings from contamination.
- Electronic speed control with soft-start allows smooth and consistent performance

Standard Equipment: Lock Nut Wrench, Grip.

- MULTI TOOL
- GRINDING
- SANDING / POLISHING
- SAWING
- ROUTERING / PLANING



Angle Grinder - 1,650W - 2,000W (Finger Trigger Switch) Acc Pg. A099-128 **153**

GA7001 180mm (7")

Continuous rating input	115V : 1,650 W
Capacity	220 - 240V : 2,000 W Depressed center wheel : 180 mm (7") Wire cup brush : 110 mm (4-3/8") Cut-off wheel : 180 mm (7") Abrasive disc : 180 mm (7")
No load speed	8,000 rpm
Overall length	411.5 mm (16-1/4")
Spindle thread	DIN type
Net weight	5.7 kg (12.6 lbs)
Power supply cord	2.5 m (8.2 ft)

A tough contender, very rugged and powerful.

- Powerful motor in tough, aluminium body.

Standard Equipment: Lock Nut Wrench, Grip.

- CLEANING
- HEAT GUN / LASERS
- PNEUMATIC TOOLS
- GARDEN TOOLS
- GENERATORS



Angle Grinder - 1,650W - 2,000W (Large Trigger Switch) Acc Pg. A099-128 **204**

GA7050 180mm (7") GA9050 230mm (9")

Continuous rating input	127V : 1,650 W 220 - 240V : 2,000 W	127V : 1,650 W 220 - 240V : 2,000 W
Wheel Diameter	180 mm (7")	230 mm (9")
No Load Speed (RPM)	8,500	6,600
Vibration Level	Surface Grinding: 6.5 m/s ² Disc Sanding: 4.0 m/s ²	Surface Grinding: 5.5 m/s ² Disc Sanding: 2.5 m/s ²
Sound Pressure Level	94 dB(A)	94 dB(A)
Sound Power Level	105 dB(A)	105 dB(A)
Dimensions (L x W x H)	432x200x132 mm (17"x7-7/8"x5-3/16")	432x250x132 mm (17"x9-7/8"x5-3/16")
Net weight	3.98 kg (8.8 lbs)	4.64 kg (10.2 lbs)
Power supply cord	2.5 m (8.2 ft)	2.5 m (8.2 ft)

Most compact in its class

- Small and rotatable gear housing.
- Large trigger switch.
- Light weight.

Standard Equipment: Lock Nut Wrench, Grip.

ANTI RESTART



1650W MOTOR 127V

2000W MOTOR 220V - 240V



Angle Grinder - 1,650W-2,000W (Anti Restart) (Large Trigger Switch) Acc Pg. A099-128 204

	GA7050R 180mm (7")	GA9050R 230mm (9")
Continuous rating input	127V : 1,650 W 220 - 240V : 2,000 W	127V : 1,650 W 220 - 240V : 2,000 W
Wheel Diameter	180 mm (7")	230 mm (9")
No Load Speed (RPM)	8,500	6,600
Vibration Level	Surface Grinding: 6.5 m/s ² Disc Sanding: 4.0 m/s ²	Surface Grinding: 5.5 m/s ² Disc Sanding: 2.5 m/s ²
Sound Pressure Level	94 dB(A)	94 dB(A)
Sound Power Level	105 dB(A)	105 dB(A)
Dimensions (L x W x H)	455x200x132 mm (17-7/8" x 7-7/8" x 5-3/16")	455x250x132 mm (17-7/8" x 9-7/8" x 5-3/16")
Net weight	4.6 kg (10.3 lbs.)	4.8 (10.6 lbs)
Power supply cord	2.5 m (8.2 ft)	2.5 m (8.2 ft)

Most compact in its class

- Small and rotatable gear housing.
- Large trigger switch.
- Light weight.

Standard Equipment: Lock Nut Wrench, Grip.

CORDLESS

FIXING /
FASTENINGDRILLING /
IMPACT DRILLINGCONCRETE DRILLING /
DEMOLITIONCUTTING
[CONCRETE / MASONRY /
METAL]

MULTI TOOL

GRINDING

SANDING /
POLISHING

SAWING

ROUTERING /
PLANING

CLEANING

HEAT GUN / LASERS

PNEUMATIC TOOLS

GARDEN TOOLS

GENERATORS



2,200W MOTOR



Angle Grinder - 2,200W (Large Trigger Switch) Acc Pg. A099-128 204

	GA7020 180mm (7")	GA9020 230mm (9")
Continuous rating input	2,200W	2,200W
Wheel Diameter	180 mm (7")	230 mm (9")
No Load Speed (RPM)	8,500	6,600
Vibration Level	Surface Grinding : 8.0 m/s ² Disc Sanding: 2.5 m/s ²	Surface Grinding: 5.5 m/s ² Disc Sanding: 2.5 m/s ² or less
Sound Pressure Level	89 dB(A)	89 dB(A)
Sound Power Level	100 dB(A)	100 dB(A)
Dimensions (L x W x H)	473x200x140 mm (18-5/8" x 7-7/8" x 5-1/2")	473x249x140 mm (18-5/8" x 9-3/4" x 5-1/2")
Net weight	5.56 kg (12.26 lbs)	5.76 kg (12.7 lbs)
Power supply cord	2.5 m (8.2 ft)	2.5 m (8.2 ft)

Outstanding durability

- Increased heat resistance.
- Superior anti-dust structure.
- Machined bevel gear for strength.
- Soft grip for more comfort and control.
- Gear housing can be positioned at every 90 degrees.

Standard Equipment: Lock Nut Wrench, Grip.

D-SHAPE HANDLE



2,200W MOTOR



Angle Grinder - 2,200W (Large Trigger Switch) Acc Pg. A099-128 218

	GA7062 180mm (7")	GA9062 230mm (9")
Continuous rating input	2,200W	2,200W
Wheel Diameter	180 mm (7")	230 mm (9")
No Load Speed (RPM)	8,500	6,600
Vibration Level	Surface Grinding : 7.5 m/s ² Disc Sanding : 2.5 m/s ²	Surface Grinding : 6.0 m/s ² Disc Sanding : 2.5 m/s ² or less
Sound Pressure Level	91 dB(A)	91 dB(A)
Sound Power Level	102 dB(A)	102 dB(A)
Dimensions (L x W x H)	450x200x144 mm (17-3/4" x 7-7/8" x 5-5/8")	450x250x144 mm (17-3/4" x 9-7/8" x 5-5/8")
Net weight	5.51 kg (12.2 lbs)	5.61 kg (12.4 lbs)
Power supply cord	2.5 m (8.2 ft)	2.5 m (8.2 ft)

High durability and Superior usability D shape Handle grinders.

- Improvement of armature, commutator, carbon brush life, switch section, shaft lock pin, new brush holder and rigid motor housing.
- D-shape Handle protects user's hand from materials
- Easy to grip handle with anti-slip shape and comfortable side grip for better balance
- Compact and light weight

Standard Equipment: Lock Nut Wrench, Grip.

- CORDLESS
- FIXING / FASTENING
- DRILLING / IMPACT DRILLING
- CONCRETE DRILLING / DEMOLITION
- CUTTING (CONCRETE/ MASONRY/ METAL)



Angle Grinder - 2,200W (Large Trigger Switch) (SJS II) Acc Pg. A099-128 **218**

	GA7063 180mm (7")	GA9063 230mm (9")
Continuous rating input	2,200W	2,200W
Wheel Diameter	180 mm (7")	230 mm (9")
No Load Speed (RPM)	8,500	6,600
Vibration Level	Surface Grinding: 6.5 m/s ² Disc Sanding : 2.5 m/s ² or less	Surface Grinding with : 5.5 m/s ² Disc Sanding : 2.5 m/s ² or less
Sound Pressure Level	91 dB(A)	91 dB(A)
Sound Power Level	102 dB(A)	102 dB(A)
Dimensions (L x W x H)	450x200x145 mm (17-3/4"x7-7/8"x5-3/4")	450x250x145 mm (17-3/4"x9-7/8"x5-3/4")
Net weight	5.64 - kg (12.4 lbs)	5.75 kg (12.7 lbs)
Power supply cord	2.5 m (8.2 ft.)	2.5 m (8.2 ft.)

High durability and Superior usability D shape Handle grinders with "Super Joint System II" developed for effective vibration absorption

- Improvement of armature, commutator, carbon brush life, switch section, shaft lock pin, new brush holder and rigid motor housing.
- D-shape Handle protects user's hand from materials
- Easy to grip handle with anti-slip shape and comfortable side grip for better balance
- Compact and light weight

Standard Equipment: Lock Nut Wrench, Grip.

- MULTI TOOL
- GRINDING
- SANDING / POLISHING
- SAWING
- ROUTERING / PLANING



Angle Grinder - 2,200W - 2,400W (Large Trigger Switch) Acc Pg. A099-128 **204**

	GA7030 180mm (7")	GA9030 230mm (9")
Continuous rating input	2,400W (220V) / 2,200W (127V)	2,400W (220V) / 2,200W (127V)
Wheel Diameter	180 mm (7")	230 mm (9")
No Load Speed (RPM)	8,500	6,600
Vibration Level	Surface Grinding: 6.5 m/s ² Disc Sanding: 2.5 m/s ²	Surface Grinding: 6.5 m/s ² Disc Sanding: 2.5 m/s ² or less
Sound Pressure Level	89 dB(A)	90 dB(A)
Sound Power Level	100 dB(A)	101 dB(A)
Dimensions (L x W x H)	511x200x140 mm (20-1/8"x7-7/8"x5-1/2")	503x250x140 mm (19-3/4"x9-7/8"x5-1/2")
Net weight	6.06 kg (13.36 lbs)	6.26 kg (13.8 lbs)
Power supply cord	2.5 m (8.2 ft)	2.5 m (8.2 ft)

Heavy duty motor with 2,200W - 2,400W continuous rating Input.

- Outstanding durability. Superior anti-dust Structure, Machined bevel gear.Increased heat resistance.
- Low vibration rear handle with soft grip for more comfort and control.
- Rotatable rear handle can be positioned to suit most cutting & grinding operations.
- Protects work piece from scratches large rubber tool rest.
- Gear housing can be positioned at every 90 degrees.

Standard Equipment: Lock Nut Wrench, Grip.

- CLEANING
- HEAT GUN / LASERS
- PNEUMATIC TOOLS
- GARDEN TOOLS
- GENERATORS



Angle Grinder - 2,600W (Large Trigger Switch) Acc Pg. A099-128 **204**

	GA7040S 180mm (7")	GA9040S 230mm (9")
Continuous rating input	2,600W	2,600W
Wheel Diameter	180 mm (7")	230 mm (9")
No Load Speed (RPM)	8,500	6,600
Vibration Level	Surface Grinding: 7.5 m/s ² Disc Sanding: 2.5 m/s ²	Surface Grinding: 5.5 m/s ² Disc Sanding: 2.5 m/s ² or less
Sound Pressure Level	90 dB(A)	90 dB(A)
Sound Power Level	101 dB(A)	101 dB(A)
Dimensions (L x W x H)	511x200x140 mm (20-1/8"x7-7/8"x5-1/2")	503x250x140 mm (19-3/4"x9-7/8"x5-1/2")
Net weight	6.45 kg (14.2 lbs)	6.65 - 8.94 kg (14.7 lbs)
Power supply cord	2.5 m (8.2 ft)	2.5 m (8.2 ft)

Heavy duty motor with 2,600W continuous rating Input.

- Outstanding durability. Superior anti-dust Structure, Machined bevel gear.Increased heat resistance.
- Low vibration rear handle with soft grip for more comfort and control.
- Rotatable rear handle can be positioned to suit most cutting & grinding operations.
- Protects work piece from scratches large rubber tool rest.
- Gear housing can be positioned at every 90 degrees.

Standard Equipment: Lock Nut Wrench, Grip.

906 6mm (1/4") Acc Pg. A124-125 **64**

Die Grinder



240W
MOTOR



Light weight for controlled Grinding operations.

- Ideal for light, precision grinding.
- Palm-sized grinder for multi-applications.
- High speed (25,000rpm) for maximum production.

Specifications:-

Continuous rating Input	240W
Capacity	Collet : 6mm or 1/4"
No load speed	25,000rpm
Overall length	283mm (11-1/8")
Net weight	0.94kg (2.1lbs)
Power supply cord	2.5m (8.2ft)

Standard Equipment: Wrench (2pcs.)

906H 6mm (1/4") Acc Pg. A124-125 **65**

Die Grinder



320W
MOTOR



A tough, durable and well balanced machine.

- Aluminum-clad, tough body.
- For pro's precision grinding.
- Can be gripped close to the stone for steadier work.

Specifications:-

Continuous rating input	320 W
Capacity	Collet : 6 mm (1/4")
No load speed	27,000 rpm
Overall length	355 mm (14")
Net weight	1.9 kg (4.2 lbs)
Power supply cord	2.5 m (8.2 ft)

Standard Equipment: Wrench (2pcs.)

GD0600 6mm (1/4") Acc Pg. A124-125 **325**

Die Grinder



400W
MOTOR



Small-circumference housing for easy handling.

- Anti-slip rubber cover for easy handling.
- Round-shaped collet nut reduces the possibility of damages/ scratches to workpiece.
- Vent slots designed to direct the exhaust air stream towards the opposite side of the operator.
- High heat resistance.
- Operate paddle type switch.

Specifications:-

Continuous rating Input	400W
Capacity	Collet : 3.6mm or 1/8", 1/4"
Wheel dia.	38mm (2-1/2")
No load speed	25,000rpm
Dimensions	358mm x 82mm x 82mm
(L x W x H)	(14-1/8" x 3-1/4" x 3-1/4")
Net weight	1.7kg (3.7lbs)
Power supply cord	2.5m (8.2ft)

Standard Equipment: Wrench (2pcs.)

GD0602 6mm (1/4") Acc Pg. A124-125 **325**

Die Grinder



400W
MOTOR



Compact body with short nose.

- Anti-slip rubber cover for easy handling.
- Round-shaped collet nut reduces the possibility of damages/scratches to the workpiece.
- Switch lever conveniently located for one hand operation.
- Vent slots designed to direct the exhaust air stream towards the opposite side of the operator.

Specifications:-

Continuous rating Input	400W
Capacity	Collet : 6mm or 1/4"
Wheel dia.	38mm (1-1/2")
No load speed (rpm)	25,000
Dimensions	264 x 82 x 82mm
(L x W x H)	(10-3/8" x 3-1/4" x 3-1/4")
Net weight	1.4kg (3.2lbs)
Power supply cord	2.5m (8.2ft)

Standard Equipment: Wrench (2pcs.)

- CORDLESS
- FIXING / FASTENING
- DRILLING / IMPACT DRILLING
- CONCRETE DRILLING / DEMOLITION
- CUTTING [CONCRETE/ MASONRY/ METAL]
- MULTI TOOL
- GRINDING
- SANDING / POLISHING
- SAWING
- ROUTERING / PLANING
- CLEANING
- HEAT GUN / LASERS
- PNEUMATIC TOOLS
- GARDEN TOOLS
- GENERATORS

- CORDLESS
- FIXING / FASTENING
- DRILLING / IMPACT DRILLING
- CONCRETE DRILLING / DEMOLITION
- CUTTING [CONCRETE/ MASONRY/ METAL]
- MULTI TOOL
- GRINDING
- SANDING / POLISHING
- SAWING
- ROUTERING / PLANING
- CLEANING
- HEAT GUN / LASERS
- PNEUMATIC TOOLS
- GARDEN TOOLS
- GENERATORS

GD0800C 8mm (1/4")
Acc Pg. A124-125 **318**

Die Grinder

High speed for mounted points - Max wheel point 25mm

750W
MOTOR

High-speed die grinder with max. 8mm collet capacity.

- Ergonomically designed slim body for grinding in tight spots.
- Super Joint System absorbs shock caused by accidental wheel lock and protects gears.
- Internal labyrinth construction seals motor and bearings from contamination.

Specifications:-

Continuous rating Input	750W
Capacity	Collet : 3,6,8mm or 1/8",1/4"
Max wheel point dia.	25mm
No load speed	7,000-28,000rpm
Dimensions (L x W x H)	371x75x75mm (14-5/8"x2-15/16"x2-15/16")
Net weight	1.7kg (3.7lbs)
Power supply cord	2.5m (8.2ft)

Standard Equipment: Wrench (2pcs)

GD0810C 8mm (1/4")
Acc Pg. A124-125 **318**

Die Grinder

Low speed for flap discs - Max wheel point 50mm

750W
MOTOR

Low-speed die grinder with max. 8mm collet capacity.

- Ergonomically designed slim body for grinding in tight spots.
- Super Joint System absorbs shock caused by accidental wheel lock and protects gears.
- Internal labyrinth construction seals motor and bearings from contamination.
- Ideal for grinding internal surfaces, removing paint etc. using with flap wheel discs.

Specifications:-

Continuous rating Input	750W
Capacity	Collet : 3,6,8mm or 1/8",1/4"
Max wheel point dia.	50mm
No load speed	1,800-7,000rpm
Overall length	371mm (14-5/8")
Net weight	1.7kg (3.8lbs)
Power supply cord	2.5m (ft)

Standard Equipment: Wrench (2pcs)

GD0801C 8mm (1/4") (Paddle switch)
Acc Pg. A124-125 **318**

Die Grinder

750W
MOTOR

Easy-to-operate paddle type on/off switch

- Ergonomically designed slim body for grinding in tight spots.
- Super Joint System absorbs shock caused by accidental wheel lock and protects gears.
- Side handle can be attached.

Specifications:-

Continuous rating input	750W
Capacity	Collet : 3,6,8mm or 1/8",1/4"
No load speed (rpm)	7,000-29,000
Dimensions (L x W x H)	390x75x88mm (15-3/8"x2-15/16"x3-1/2")
Net weight	2.0kg (4.3lbs)
Power supply cord	2.5m (8.2ft)

Standard Equipment: Wrench (2pcs)

GD0811C 8mm (1/4") (Paddle switch)
Acc Pg. A124-125 **318**

Die Grinder

750W
MOTOR

Easy-to-operate paddle type on/off switch

- Ergonomically designed slim body for grinding in tight spots.
- Super Joint System absorbs shock caused by accidental wheel lock and protects gears.
- Internal labyrinth construction seals motor and bearings from contamination.
- Ideal for grinding internal surfaces, removing paint etc. using with flap wheel discs.

Specifications:-

Continuous rating input	750W
Capacity	Collet : 3,6,8mm or 1/8",1/4"
No load speed (rpm)	1,800-7,000
Overall length	390mm (15-3/8")
Net weight	2.0kg (4.4lbs)
Power supply cord	2.5m (8.2ft)

Standard Equipment: Wrench (2pcs)

GS5000 125mm (5") // GS6000 150mm (6") - Straight Grinder

Ergonomically design handle and barrel for added extra maneuverability

Ergonomically design barrel with rubberized cover



Improved durability of gears

about two times as tough as the current by;

- (1) Change of the grease
- (2) Modification on the inside of Gear housing for grease to stay on Gears teeth.



Photo: GS6000

Rubberized soft grip provides comfortable and sure grip.

Large type trigger switch



CORDLESS

FIXING / FASTENING

DRILLING / IMPACT DRILLING

CONCRETE DRILLING / DEMOLITION

CUTTING [CONCRETE / MASONRY / METAL]

MULTI TOOL

GRINDING

SANDING / POLISHING

SAWING

ROUTERING / PLANING

CLEANING

HEAT GUN / LASERS

PNEUMATIC TOOLS

GARDEN TOOLS

GENERATORS

GS5000 125mm (5")
Acc Pg. A123 **204**

Straight Grinder

750W
MOTOR

Double insulated 125mm straight grinder
Light weight with large soft grip reduce operator's fatigue. Suitable RPM and design for a long time heavy grinding work.

Specifications:- □

Continuous rating input	750W
Wheel diameter	125mm (5")
Hole dia.	12.7,20mm (1/2,13/16")
No load speed (rpm)	5,600
Dimensions (L x W x H)	590x189x116mm (23-1/4"x7-7/16"x4-9/16")
Net weight	5.0kg (11.1lbs)
Power supply cord	2.5m (8.2ft)

Standard Equipment: Wrench (2pcs)

GS6000 150mm (6")
Acc Pg. A123 **204**

Straight Grinder

750W
MOTOR

Double insulated 150mm straight grinder
Light weight with large soft grip reduce operator's fatigue. Suitable RPM and design for a long time heavy grinding work.

Specifications:- □

Continuous rating input	750W
Wheel diameter	150mm (6")
Hole dia.	12.7,20mm (1/2,13/16")
No load speed (rpm)	5,600
Dimensions (L x W x H)	590x216x130mm (23-1/4"x8-1/2"x5-1/8")
Net weight	5.2kg (11.5lbs)
Power supply cord	2.5m (8.2ft)



Standard Equipment: Wrench (2pcs)

- CORDLESS
- FIXING / FASTENING
- DRILLING / IMPACT DRILLING
- CONCRETE DRILLING / DEMOLITION
- CUTTING [CONCRETE/ MASONRY/ METAL]
- MULTI TOOL
- GRINDING
- SANDING / POLISHING
- SAWING
- ROUTERING / PLANING
- CLEANING
- HEAT GUN / LASERS
- PNEUMATIC TOOLS
- GARDEN TOOLS
- GENERATORS

9105
Acc Pg. A123
150 W

Straight Grinder

750W
MOTOR

A well proven, mighty performance in grinding of castings and welds.

Specifications:-



Continuous rating Input	750W
Max. wheel size	125mm x 19mm (5" x 3/4")
Hole dia.	12.7mm (1/2")
No load speed	4,800rpm
Overall length	550mm (21-5/8")
Net weight	5.1kg (11.1lbs)
Power supply cord	2.5m (8.2ft)

Standard Equipment: Wrench.

GB602
Acc Pg. A123

Bench Grinder

250W
MOTOR

Steady tool maintenance from this light, yet stable performer.

- Cosmetic new design.
- The safety shields and spark deflectors are adjustable for operator's convenience.

Specifications:-

Continuous rating Input	250W
Wheel diameter	150mm x 16mm
Hole dia.	12.7mm (1/2")
H.P.	1/3
No load speed (rpm)	2,850 (50Hz) / 3,450 (60Hz)
Dimensions (L x W x H)	375 x 205 x 286mm
Net weight	9.2kg (20.3lbs)

Standard Equipment: Eye Shields

GB800
Acc Pg. A123

Bench Grinder

540W
MOTOR



With a large 540W motor, GB800 is perfect for light industrial applications.

- Comes with protective shields and tool rests.witch.

Specifications:-



Continuous rating input	540 W
Max. wheel size	205 mm x 25 mm (8" x 1")
Distance between wheels	345 mm (13-9/16")
H.P.	3/4
No load speed	2,850 rpm
Overall length	455 mm (18")
Net weight	18.5 kg (40.8 lbs)

Standard Equipment: Eye Shields

GB801
Acc Pg. A123

Bench Grinder

550W
MOTOR

Steady tool maintenance from this light, yet stable performer.

- Cosmetic new design.
- Balance weight installed.
- Integral work lights automatically turn on to illuminate the work area for more accurate grinding and polishing .

Specifications:-

Continuous rating Input	550W
Wheel diameter	205mm x 19mm
Hole dia.	15.88mm (5/8")
H.P.	3/4
No load speed (rpm)	2,850 (50Hz) / 3,450 (60Hz)
Dimensions (L x W x H)	395 x 265 x 333mm
Net weight	19.8kg (43.6lbs)

Standard Equipment: Eye Shields



Concrete Planer

PC1100 110mm (4-3/8")
Acc Pg. A106-A107 **100**

Concrete Planer



1020W
MOTOR



Smooth finishes on concrete surfaces or levelling of concrete seams.

- Dry cutting diamond wheel for planing without water.
- Front roller adjusts planing depth.
- Dust bag for clean operation.
- Lock-on button for continuous operation.

Specifications:-

Continuous rating Input	1,020W
Wheel dia.	110mm (4-3/8")
Hole dia.	15mm (5/8")
No load speed	10,000rpm
Overall length	418mm (16-1/2")
Net weight	4.3kg (9.5lbs)
Power supply cord	2.5m (8.2ft)

Standard Equipment: Lock Nut Wrench, Hex Wrench, Screwdriver, Dust Bag Assembly.

- CORDLESS
- FIXING / FASTENING
- DRILLING / IMPACT DRILLING
- CONCRETE DRILLING / DEMOLITION
- CUTTING [CONCRETE/ MASONRY/ METAL]
- MULTI TOOL
- GRINDING
- SANDING / POLISHING
- SAWING
- ROUTERING / PLANING
- CLEANING
- HEAT GUN / LASERS
- PNEUMATIC TOOLS
- GARDEN TOOLS
- GENERATORS

PC5000C 125mm (5")
Acc Pg. A106-A107 **253**

Concrete Planer



1400W
MOTOR



Most suitable for planing concrete.

- Capable of planing flush to corners.
- Powerful 1,400W motor provides efficient planing operation.
- Anti-restart function is provided.
- Electrical current limiter protects motor from overload.

Specifications:-

Continuous rating Input	1,400W
Wheel dia.	125mm (5")
Hole dia.	22.23mm (7/8")
No load speed (rpm)	10,000
Dimensions (L x W x H)	437 x 235 x 195mm (17-1/8" x 9-1/4" x 7-5/8")
Net weight	4.0kg (8.9lbs)
Power supply cord	5.0m (16.4ft)

Standard Equipment: Lock Nut Wrench, Hex Wrench, Dust Bag Assembly

PC5001C 125mm (5")
Acc Pg. A106-A107 **253**

Concrete Planer



1400W
MOTOR

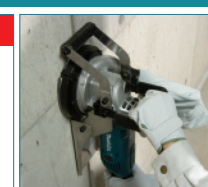

Most suitable for planing concrete.

- Front roller adjusts planing depth. / Auxiliary base for smoother planing.
- Capable of planing flush to corners.
- Powerful 1,400W motor provides efficient planing operation.
- Anti-restart function is provided.
- Electrical current limiter protects motor from overload.

Specifications:-

Continuous rating Input	1,400W
Wheel dia.	125mm (5")
Hole dia.	22.23mm (7/8")
No load speed (rpm)	10,000
Dimensions (L x W x H)	479 x 182 x 195mm (18-13/16" x 7-1/8" x 7-5/8")
Net weight	5.1kg (11.2lbs)
Power supply cord	5.0m (16.4ft)

Standard Equipment: Lock Nut Wrench, Hex Wrench, Dust Bag Assembly

Sanding / Polishing

Disc Sander, Polisher, Angle Sander,
Stone Polisher, Belt Sander, Wheel Sander,
Finishing Sander, Orbital Sander,
Random Orbit Sander



GV6010 150mm (6") Acc Pg. A134-139 **64** 

Disc Sander





Improved cooling airflow

- Ergonomically designed handle with rubberized soft grip



Specifications:- 

Continuous rating Input	440W
Capacity	Abrasive disc :150mm (6") Pad : 120mm (4-3/4")
No load speed (rpm)	4,500
Dimensions (L x W x H)	200 x 74 x 181mm (7-7/8" x 2-15/16" x 7-1/8")
Net weight	1.2kg (2.6lbs)
Power supply cord	2.5m (8.2ft)

Standard Equipment: Hex Wrench, Grip

9218SB 180mm (7") Acc Pg. A118 **100** 

Disc Sander

Well-balanced body for fast and steady sanding

- Lock-on button for continuous use and reduced operator fatigue.

Specifications:- 

Continuous rating Input	570W
Capacity	Wire cup brush : 110mm (4-3/8") Abrasive disc : 180mm (7")
No load speed	4,500rpm
Overall length	225mm (8-7/8")
Net weight	2.9kg (6.3lbs)
Power supply cord	2.5m (8.2ft)

Standard Equipment: Lock Nut Wrench, Grip.

GV7000C 180mm (7") Acc Pg. A118 **303** 

Disc Sander





Compact body with low center of gravity for absolutely controlled operation and reduced fatigue

- Lock-on button for continuous use
- Variable speed control plus Electronic control

Specifications:-    

Continuous rating Input	900W
Capacity	Abrasive disc : 180mm (7") Pad : 180mm (7")
No load speed	2,500-4,700rpm
Overall length	210mm (8-1/4")
Net weight	2.1kg (4.6lbs)
Power supply cord	2.5m (8.2ft)

Standard Equipment: Lock Nut Wrench, Grip

9218PB 180mm (7") Acc Pg. A136-139 **100** 

Polisher



Better polishing action for a wide range of applications

- Easy handling to reduced operator fatigue

Specifications:- 

Continuous rating Input	570W
Capacity	Wool bonnet : 180mm (7")
No load speed	2,000rpm
Overall length	235mm (9-1/4")
Net weight	2.7kg (5.9lbs)
Power supply cord	2.5m (8.2ft)

Standard Equipment: Lock Nut Wrench, Grip

CORDLESS

FIXING / FASTENING

DRILLING / IMPACT DRILLING

CONCRETE DRILLING / DEMOLITION

CUTTING [CONCRETE/ MASONRY/ METAL]

MULTI TOOL

GRINDING

SANDING / POLISHING

SAWING

ROUTERING / PLANING

CLEANING

HEAT GUN / LASERS

PNEUMATIC TOOLS

GARDEN TOOLS

GENERATORS

- CORDLESS
- FIXING / FASTENING
- DRILLING / IMPACT DRILLING
- CONCRETE DRILLING / DEMOLITION
- CUTTING (CONCRETE/ MASONRY/ METAL)
- MULTI TOOL
- GRINDING
- SANDING / POLISHING

PV7000C 180mm (7") Acc Pg. A134-139 **303**

Polisher



Compact body with low center of gravity for absolutely controlled operation and reduced fatigue

- Electronic control for consistent speed
- 2 speed plus variable speed control for a wide range of polishing works
- Pre-setting speed control dial
- Durable cord guard
- Quick-flip speed change for compounding and polishing

Specifications:-

Continuous rating Input Capacity	900W Abrasive disc : 180mm (7") Pad : 170mm (6-11/16")
No load speed	600-2,000rpm
Overall length	210mm (8-1/4")
Net weight	2.1kg (4.6lbs)
Power supply cord	2.5m (8.2ft)

Standard Equipment: Wrench, Side Grip

9207SPB 180mm (7") Acc Pg. A134-139 **100**

Sander-Polisher



2-speed (2,000rpm & 3,800rpm) for use as a sander or polisher

- Packs Makita's basic concepts of a sander-polisher

Specifications:-

Continuous rating Input Capacity	700W Abrasive disc : 180mm (7") Diamond wheel : 180mm (7")
No load speed	2,000 / 3,800rpm
Overall length	455mm (17-7/8")
Net weight	3.4kg (7.5lbs)
Power supply cord	2.5m (8.2ft)

Standard Equipment: Lock Nut Wrench, Grip

- SAWING
- ROUTERING / PLANING
- CLEANING
- HEAT GUN / LASERS
- PNEUMATIC TOOLS
- GARDEN TOOLS
- GENERATORS

9237CB 180mm (7") Acc Pg. A134-139

Polisher



Loop handle with rubberized soft grip.

- Variable speed control by dial Rotation speed is adjustable to application.
- Vent dust cover of screw-down type prevents ingress of wool fibers.
- Elastomer bumper on gear housing protects a precious surface, such as that of car body, from damage and scratches

Specifications:-

Continuous rating input Capacity	1,200W Wool Pad: 180 mm (7") Wool Bonnet: 180 mm (7")
No Load Speed (RPM)	0 - 3,200
Vibration Level	2.5 m/s ² or less
Sound Pressure Level	83 dB(A)
Sound Power Level	94 dB(A)
Dimensions (L x W x H)	431x198x187 mm (17"x7-3/4"x7-3/8")
Net weight	3.4 kg (7.5 lbs.)
Power supply cord	2.5 m (8.2 ft)

Standard Equipment: Loop handle, Hex wrench

PO600C 150 mm (6") Acc Pg. A134-139

Random Orbit Polisher



Selectable two rotation mode: Random orbit with forced rotation mode for rough polishing & Random orbit mode for fine polishing

- Random orbit with forced rotation mode is orbital action with forced rotation of the pad for rough polishing such as surface treatment
- Random orbit mode is orbital action with free rotation of the pad for fine polishing
- Setting up RPM in the full speed is easy by a variable speed dial

Specifications:-

Continuous rating input	900W
Pad Size	150 mm (6")
Orbits Per Minute (OPM)	0 - 6,800
Strokes Per Minute (SPM)	0 - 13,600
No Load Speed (RPM)	0 - 780
Orbit Diameter	5.5 mm (7/32")
Vibration Level	Polishing: 7.0 m/s ²
Sound Pressure Level	83 dB(A)
Sound Power Level	94 dB(A)
Dimensions (L x W x H)	451x148x126 mm (17-3/4"x5-7/8"x5")
Net weight	2.8 kg (6.2 lbs)
Power supply cord	4.0 m (13.1 ft)

Standard Equipment: Side grip, Hex Wrench

SA7000C 180mm (7")

Acc Pg. A134-139 **204** 

Angle Sander



Powerful 1,600W motor delivers outstanding performance for industrial use

- Motor has outstanding heat resistance to protect from overheating
- Speed control dial allows you to adjust maximum speed in 6 stages from 1,500 to 4,000rpm
- Variable speed trigger switch for controlled sanding.
- Lightweight, reducing operator fatigue in continuous use.

Specifications:-



Continuous rating Input	1,600W
Capacity	Abrasive disc : 180mm (7") Pad : 180mm (7")
No load speed	0-4,000rpm
Dimensions	453mm x 170mm x 136mm (17-7/8" x 6-11/16" x 5-3/8")
Net weight	3.4kg (7.5lbs)
Power supply cord	2.5m (8.2ft)

Standard Equipment: Lock Nut Wrench 35, Grip

SA7021

Acc Pg. A134-139 **204** 

Angle Sander



Outstanding durability

- Increased heat resistance.
- Superior anti-dust structure.
- Machined bevel gear for strength.
- Soft grip for more comfort and control.
- Gear housing can be positioned at every 90 degrees

Specifications:-



Continuous rating Input	2,200W
Capacity	Depressed center wheel : 180, 230mm (7, 9") Abrasive disc : 180mm (7")
No load speed	6,600rpm
Dimensions (L x W x H)	473 x 105 x 140mm (18-5/8" x 4-1/8" x 5-1/2")
Net weight	5.0kg (11.1lbs)
Power supply cord	2.5m (8.2ft)

Standard Equipment: Lock Nut Wrench, Grip

PW5001C

Acc Pg. A136-139 **318** 

Stone Polisher

Marble / Granite



Ideal for effective stone polishing

- Speed control dial for setting the optimum speed for application.
- Three water supply holes evenly wet every channel of the polishing pad, protecting it from overheating and getting clogged with dust.
- Ergonomically designed tool head provides comfortable grip.
- Conveniently located valve allows easy water flow control

Specifications:-



Continuous rating Input	900W
Capacity	Pad : 100-125mm (4-5")
No load speed	2,000-4,000rpm
Overall length	359mm (14-1/8")
Net weight	2.2kg (5.1lbs)
Power supply cord	4.0m (13.1ft)

Standard Equipment: Side Grip, Wrench

9032 9mm X 533mm

Acc Pg. A130 **411** 

Belt Sander



Max. sanding depth 110 mm

- Adjustable sanding arm pivots 100 degrees for hard to reach areas
- Electronic speed control dial for fine work
- Easily adjustable belt tracking with a turn of the knob
- Dust-free work with Makita dust collection system
- Optional 6mm and 13mm sanding bars for a wide range of sanding and filing jobs

Specifications:-



Continuous rating Input	500W
Belt size	9 x 533mm (3/8" x 21")
Belt speed	300 - 1,700m / min. (980 - 5,600ft/ min)
Max. sanding depth	110mm (4-5/16")
Overall length	420mm (16-1/2")
Net weight	1.6kg (3.5lbs)
Power supply cord	2.5m (8.2ft)

CORDLESS

FIXING / FASTENING

DRILLING / IMPACT DRILLING

CONCRETE DRILLING / DEMOLITION

CUTTING [CONCRETE/ MASONRY/ METAL]

MULTI TOOL

GRINDING

SANDING / POLISHING

SAWING

ROUTERING / PLANING

CLEANING

HEAT GUN / LASERS

PNEUMATIC TOOLS

GARDEN TOOLS

GENERATORS

CORDLESS

9031 30mm x 533mm (1-3/16" x 21")

Acc Pg. A130 **411**

Belt Sander



Optimum for use in close quarters or on irregular shapes

- Belt speed can be adjusted for sanding a wide variety of materials
- Multi-position side handle for easy and comfortable operation.
- Lock-on button for continuous operation

Specifications:-



Continuous rating Input	550W
Belt size	30 x 533mm (1-3/16" x 21")
Belt speed	200 - 1,000m / min. (656 - 3,280ft/ min)
Overall length	380mm (15")
Net weight	2.1kg (4.6lbs)
Power supply cord	2.5m (8.2ft)

FIXING / FASTENING

DRILLING / IMPACT DRILLING

CONCRETE DRILLING / DEMOLITION

CUTTING [CONCRETE/ MASONRY/ METAL]

MULTI TOOL

GRINDING

SANDING / POLISHING

9910 76mm x 457mm (3" x 18")

Acc Pg. A130 **411**

Belt Sander



Compact and well balanced for easy operation

- Unique design allows flush sanding to a wall.
- Flat top design allows sander to be turned and used as a bench top tool.
- Low noise at only 82dB for quieter operation.
- Auto-tracking belt system requires no adjustment after in stalling belt

Specifications:-



Continuous rating Input	650W
Belt size	76 x 457mm (3" x 18")
Belt speed	270m / min. (900ft/ min)
Overall length	262mm (10-5/16")
Net weight	2.7kg (6.0lbs)
Power supply cord	2.5m (8.2ft)

Standard Equipment: Dust bag assembly

SAWING

9924DB 76mm x 610mm (3" x 24")

Acc Pg. A130 **100**

Belt Sander



Sufficient power, proven reliability and wellbalanced design : pro's choice for years

- Extended base to allow flush sanding.
- Replaceable ceramic wear-plate for easy maintenance.
- Easy lever control to change belts

Specifications:-



Continuous rating Input	850W
Belt size	76 x 610, 620mm (3" x 24, 24-3/8")
Belt speed	400m / min. (1,300ft/ min)
Overall length	355mm (14")
Net weight	4.8kg (10.6lbs)
Power supply cord	5.0m (16.4ft)

Standard Equipment: Dust bag assembly

HEAT GUN / LASERS

PNEUMATIC TOOLS

GARDEN TOOLS

GENERATORS

ROUTERING / PLANING

CLEANING

9920 76mm x 610mm (3" x 24")

Acc Pg. A130 **303**

Belt Sander



Features auto-tracking belt system, high dust collecting capacity, low noise at only 85dB

- Flush sanding possible
- Electronic variable speed control feature

Specifications:-



Continuous rating Input	1,010W
Belt size	76 x 610mm (3" x 24")
Belt speed	210 - 440m / min. (690 - 1,440ft/ min)
Overall length	334mm (13-1/8")
Net weight	4.5kg (9.9lbs)
Power supply cord	5.0m (16.4ft)

Standard Equipment: Dust bag assembly

9401 100mm x 610mm (4" x 24")

Acc Pg. A130 **153**

Belt Sander



Perfect for flush-along-side sanding as well as open areas

- Highly-efficient dust collection system for clean work environment.
- Low center of gravity makes sander ideally balanced for superior handling.

Specifications:-



Continuous rating Input	940W
Belt size	100mm x 610mm (4" x 24")
Belt speed	350m / min. (1,150ft/ min)
Overall length	374mm (14-3/4")
Net weight	7.4kg (16.3lbs)
Power supply cord	5.0m (16.4ft)

Standard Equipment: Dust Bag Assembly

9403 100mm x 610mm (4" x 24")

Acc Pg. A130 **303**

Belt Sander



Powerful 1,200W motor for high production use

- Quietest belt sander in its class (84dB).
- 500 m/min belt speed for fast material removal.
- Labyrinth construction seals motor and bearings from contamination.
- Dust bag swivels 360 degrees for convenience

Specifications:-



Continuous rating Input	1,200W
Belt size	100mm x 610mm (4" x 24")
Belt speed	500m / min. (1,640ft/ min)
Overall length	353mm (13-7/8")
Net weight	5.7kg (12.6lbs)
Power supply cord	5.0m (16.4ft)

Standard Equipment:Dust Bag Assembly

9404 100mm x 610mm (4" x 24")

Acc Pg. A130 **303**

Belt Sander



Features auto-tracking belt system, high dust collecting capacity, low noise at only 85dB

- Unique design allows flush sanding to a wall with side of sander
- Electronic variable speed control feature

Specifications:-



Continuous rating Input	1,010W
Belt size	100 mm x 610mm (4" x 24")
Belt speed	210 - 440m / min. (660 - 1,440ft/ min)
Overall length	334mm (13-1/8")
Net weight	4.7 kg (10.6lbs)
Power supply cord	5.0m (16.4ft)

Standard Equipment: Dust Bag Assembly

9741

Acc Pg. A136 **100**

Wheel Sander



Unique sanding solution for variety of materials

- Brings out beautiful wood grain with nylon brush wheel.
- For fast and efficient paint and rust removal with optional wheels.
- Well balanced design with a low center of gravity and large front loop handle for easy handling.
- Connects to a dust collector for cleaner operation

Specifications:-



Continuous rating Input	860W
Wheel dia.	100 x 120mm (4 x 4-3/4")
No load speed	3,500rpm
Overall length	310mm (12-1/4")
Net weight	4.2kg (9.3lbs)
Power supply cord	5.0m (16.4ft)

Standard Equipment: Hex Wrenches

CORDLESS

FIXING / FASTENING

DRILLING / IMPACT DRILLING

CONCRETE DRILLING / DEMOLITION

CUTTING [CONCRETE/ MASONRY/ METAL]

MULTI TOOL

GRINDING

SANDING / POLISHING

SAWING

ROUTERING / PLANING

CLEANING

HEAT GUN / LASERS

PNEUMATIC TOOLS

GARDEN TOOLS

GENERATORS

- CORDLESS
- FIXING / FASTENING
- DRILLING / IMPACT DRILLING
- CONCRETE DRILLING / DEMOLITION
- CUTTING [CONCRETE/ MASONRY/ METAL]
- MULTI TOOL
- GRINDING
- SANDING / POLISHING
- SAWING
- ROUTERING / PLANING
- CLEANING
- HEAT GUN / LASERS
- PNEUMATIC TOOLS
- GARDEN TOOLS
- GENERATORS

BO3700
Acc Pg. A131-132 64

Finishing Sander



Features efficient through-the pad dust collection system

- Ergonomically designed tool-top, comfortable control even with one-hand.
- Large levers for quick and easy changing of paper.
- Large trigger switch for easy operation.

Specifications:-

Continuous rating Input	180W
Pad size	93mm x 185 mm (3-5/8" x 7-1/4")
Abrasive paper size	93mm x 228mm (3-5/8" x 9")
Orbits per min.	10,000 opm
Overall length	254mm (10")
Net weight	1.4kg (3.1lbs)
Power supply cord	2.0m (6.6ft)

Standard Equipment: Dust Box

BO3710
Acc Pg. A131-132 64

Finishing Sander

Ergonomic tool body fits user's hand perfectly, providing sure grip and easy handling whether in single- or double-handed operation

- Durable aluminium foot with dust protection
- Powerful heavy-duty motor featuring increased power input obtained by redesigned cooling system
- Easy-to-operate paper clamp with large clamp lever ensures quick and easy paper replacement

Specifications:-

Continuous rating Input	190W
Pad size	92 x 185mm (3-5/8" x 7-1/4")
Abrasive paper size	93 x 228mm (3-5/8" x 9")
Orbits per minute (opm)	11,000
Dimensions (L x W x H)	253 x 92 x 153mm (10" x 3-5/8" x 6")
Net weight	1.6kg (3.5lbs)
Power supply cord	2.0m (6.6ft)

Standard Equipment: Dust Box

BO4900
Acc Pg. A131 419

Finishing Sander



1/2 Sheet 330 W Finishing Sander

- Through-the-Pad Dust Collection System
- Uses commonly available 115 mm x 232 mm hook-and-loop or 4-1/2" x 11" half sheet abrasive paper
- Efficient through-the-pad dust collection system for a cleaner work environment
- Minimized vibration and contoured grips for added comfort
- Large trigger switch for easier operation

Specifications:-

Continuous rating Input	330W
Pad size	115mm x 229 mm (4-1/2" x 9")
Abrasive paper size	115mm x 232mm (4-1/2" x 9-1/8")
Orbits per min.	10,000 opm
Overall length	289mm (11-3/8")
Net weight	2.7kg (6.0lbs)
Power supply cord	2.5m (8.2ft)

Standard Equipment: Dust Bag

BO4901
Acc Pg. A131-132 419

Finishing Sander



1/2 Sheet 330 W Finishing Sander

Minimized vibration for reduced operator fatigue

- Minimized vibration level for reduced operator fatigue
- Ergonomic handles for absolutely controlled operation
- Large clamp lever for easy install / removal of paper
- Through-the-pad dust collection with Makita vacuum cleaner
- Efficient through-the-pad dust collection system for a cleaner work environment

Specifications:-

Continuous rating Input	330W
Pad size	115mm x 229 mm (4-1/2" x 9")
Abrasive paper size	115mm x 280mm (4-1/2" x 11")
Orbits per min.	10,000 opm
Overall length	289mm (11-3/8")
Net weight	2.7kg (6.0lbs)
Power supply cord	2.5m (8.2ft)

9045B

Acc Pg. A131 100 

Finishing Sander

Sufficient power, proven reliability and well balanced design: professionals choice for years

- Optimum for sanding of broad surfaces with a powerful 520 W motor and wider sanding paper.
- All bearing construction for smooth, long term operation

Specifications:-



Continuous rating input	520W
Pad size	114 mm x 234 mm (4-1/2" x 9-1/4")
Abrasive paper size	114 mm x 280 mm (4-1/2" x 11")
Orbits per min.	10,000 opm
Orbit diameter	2.4 mm (3/32")
Overall length	240 mm (9-1/2")
Net weight	2.6 kg (5.7 lbs.)
Power supply cord	2.5 m (8.2 ft.)

9046

Acc Pg. A131-132 419 

Orbital Sander

Powerful 600W performer for professional's needs

- Accepts standard abrasive paper; as well as hook & loop abrasive paper.

Specifications:-



Continuous rating input	600W
Pad dia.	115 mm x 229 mm (4-1/2" x 9")
Abrasive paper size	115 mm x 280 mm (4-1/2" x 11")
Orbits per min.	6,000 opm
Overall length	283 mm (11-1/8")
Orbit diameter	5 mm (3/16")
Net weight	3.1 kg (6.8 lbs)
Power supply cord	2.5 m (8.2 ft)

Standard Equipment: Dust Bag.

B04510

Acc Pg. A131-132 64 

Finishing Sander

The popular performer

- Easy one-hand operation.
- Flush sands all four sides

Specifications:-



Continuous rating Input	180W
Pad size	110mm x 100 mm (4-3/8" x 4")
Abrasive paper size	114mm x 140mm (4-1/2" x 5-1/2")
Orbits per min.	12,000 opm
Overall length	115mm (4-1/2")
Net weight	1.0kg (2.3lbs)
Power supply cord	2.5m (8.2ft)

B04556

Acc Pg. A131-132 419 

Finishing Sander

Powerful 200W motor, low vibration, low noise

- Powerful 200W motor.
- Easy installation/removal of paper with rolled clamber's edges.
- Rubber switch cover prevents ingress of dust.
- Ergonomically contoured grip with non-skid elastomer covered surface.
- Durable aluminum foot with dust protection

Specifications:-



Continuous rating Input	200W
Pad size	112 x 102mm (4-3/8" x 4")
Abrasive paper size	114 x 140mm (4-1/2" x 5-1/2")
Dimensions (L x W x H)	131 x 112 x 141mm (5-1/8" x 4-3/8" x 5-9/16")
Orbits per minute	14,000 opm
Net weight	1.1kg (2.5lbs)
Power supply cord	2.0m (6.6ft)

Standard Equipment: Dust Bag.

CORDLESS

FIXING /
FASTENINGDRILLING /
IMPACT DRILLINGCONCRETE DRILLING /
DEMOLITIONCUTTING
[CONCRETE/ MASONRY/
METAL]

MULTI TOOL

GRINDING

SANDING /
POLISHING

SAWING

ROUTERING /
PLANING

CLEANING

HEAT GUN / LASERS

PNEUMATIC TOOLS

GARDEN TOOLS

GENERATORS

CORDLESS

BO4566

Acc Pg. A131 **419**

Finishing Sander



Superb sanding of blinds, louvers and shutters

- Powerful motor.
- Ergonomically contoured grip with non-skid elastomer covered surface.
- Rubber switch cover prevents ingress of dust.
- Built-in dust extraction.
- Durable aluminum foot with dust protection

Specifications:-



Continuous rating Input	200W
Pad size	100 x 164mm (3-15/16" x 6-1/2")
Abrasive paper size	102 x 166mm (4" x 6-1/2")
Orbits per minute (opm)	14,000
Dimensions (L x W x H)	197 x 100 x 137mm (7-3/4" x 3-15/16" x 5-3/8")
Net weight	1.2kg (2.6lbs)
Power supply cord	2.0m (6.6ft)

Standard Equipment: Dust Box.

FIXING / FASTENING

DRILLING / IMPACT DRILLING

CONCRETE DRILLING / DEMOLITION

CUTTING (CONCRETE/ MASONRY/ METAL)

MULTI TOOL

GRINDING

SANDING / POLISHING

SAWING

ROUTERING / PLANING

CLEANING

HEAT GUN / LASERS

PNEUMATIC TOOLS

GARDEN TOOLS

GENERATORS

BO5030

Acc Pg. A133 **419**

Random Orbit Sander



Powerful 300W motor and high durability

- Ergonomically designed rubberized top-cover and body provide more control and comfort.
- Rubber switch cover prevents ingress of dust.
- Convenient pad brake for fast stop.

Specifications:-



Continuous rating Input	300W
Pad diameter	123mm (4-7/8")
Abrasive disc diameter	125mm (5")
Orbits per minute (opm)	12,000
Dimensions (L x W x H)	153 x 123 x 153mm (6" x 4-7/8" x 6")
Net weight	1.3kg (2.9lbs)
Power supply cord	2.0m (6.6ft)

Standard Equipment: Dust Box.

BO5041

Acc Pg. A133 **64**

Random Orbit Sander



Ergonomically designed body and rotatable front grip provides more control and comfort.

- High power motor.
- High durability by large size of ball bearing.
- Built-in dust extraction.
- High dust extraction rate.
- Speed control dial.

Specifications:-



Continuous rating Input	300W
Pad diameter	123mm (4-7/8")
Abrasive disc diameter	125mm (5")
Orbits per minute (opm)	4,000-12,000
Dimensions (L x W x H)	218 x 123 x 153mm (8-5/8" x 4-7/8" x 6")
Net weight	1.4kg (3.1lbs)
Power supply cord	2.0m (6.6ft)

Standard Equipment: Dust Box

BO6030

Acc Pg. A133-134 **419**

Random Orbit Sander



Exceptionally low vibration, yet aggressive sanding

- Through-the-pad dust collection system for a cleaner job site.
- Ergonomic handles for controlled operation.
- Pad control system prevents gouging.
- Variable speed control dial to match the sanding speed to the material.

Specifications:-



Continuous rating Input	310W
Pad diameter	150mm (6")
Abrasive disc diameter	150mm (6")
Orbits per min.	4,000-10,000 opm
Overall length	309mm (12-1/8")
Orbit diameter	3.0mm (1/8")
Net weight	2.4kg (5.2lbs)
Power supply cord	2.5m (8.2ft)

Standard Equipment: Hex Wrench, Dust Bag.

BO6050J

Acc Pg. A133-134 326

Random Orbit Sander



WITH MAKPAC



150mm (6") random orbit sander with excellent operability

- Ergonomically designed palm grip with elastomer
- Change lever protection system; When the switch is slide to ON position change lever is automatically locked for protection from damage caused by rotating armature.
- Toolless pad change; enables quick pad change to suit application.

2 mode operation



a) Traditional random orbit mode

For fine finish sanding and buffing the motion of the pad is orbital action plus random action or free-rotation. This stops when firm hand pressure is exerted on the tool



b) The alternative roto-orbit mode

Ideal for stock removal, coarse sanding and polishing. Here the motion of the pad is a combination of orbital action and power driven rotation.

Slim skirt

Provides higher work efficiency in tight spaces.



Slim barrel grip



Specifications:-



Continuous rating input	750W
Pad diameter	150mm (6")
Abrasive disc diameter	150mm (6")
Orbits per minute (opm)	1,600 - 6,800
Sanding strokes per minute (spm)	3,200 - 13,600
Pad speed in Roto-orbit mode (rpm)	140 - 600
Orbit diameter	5.5mm (7/32")
Dimensions (L x W x H)	330x155x145mm (13"x6-1/8"x5-3/4")
Net weight	2.6kg (5.7lbs)
Power supply cord	2.5m (8.2ft)

Standard Equipment: Abrasive disc, Dust nozzle, Side grip, Pad protector



CORDLESS

FIXING /
FASTENINGDRILLING /
IMPACT DRILLINGCONCRETE DRILLING /
DEMOLITIONCUTTING
[CONCRETE/ MASONRY/
METAL]

MULTI TOOL

GRINDING

SANDING /
POLISHING

SAWING

ROUTERING /
PLANING

CLEANING

HEAT GUN / LASERS

PNEUMATIC TOOLS

GARDEN TOOLS

GENERATORS

Sawing

Slide Compound Miter Saw, Circular Saw, Table Saw
Jig Saw, Reciprocating Saw, Scroll Saw, Band Saw



DXT

Deep and Exact Cutting Technology

Diameter of slide pipe is changed from 25mm to 30mm. Moreover, by redesigning arm section shape, the precision at bevel cutting is increased



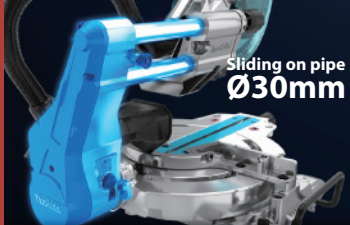

Sliding on pipe
Ø30mm

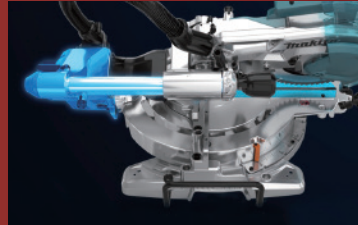

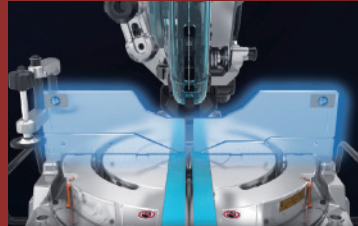

Integration of Guide fence and Lower fences provides the rigidity more than the separation structure.

- CORDLESS
- FIXING / FASTENING
- DRILLING / IMPACT DRILLING
- CONCRETE DRILLING / DEMOLITION
- CUTTING [CONCRETE/ MASONRY/ METAL]
- MULTI TOOL
- GRINDING
- SANDING / POLISHING
- SAWING
- ROUTERING / PLANING
- CLEANING
- HEAT GUN / LASERS
- PNEUMATIC TOOLS
- GARDEN TOOLS
- GENERATORS

LS1019L 260 mm (10-1/4")
Acc Pg. A143-161 **153**

Slide Compound Miter Saw (DXT)



Deep and Exact Cutting Technology



Single sliding system enables smooth operation to produce superior cuts

- Large turn base supports workpiece securely for increased stability
- Integrated guide fences for increased rigidity and high cutting accuracy
- Increased dust extraction rate for a cleaner work environment
- Rail-forward design enables to be placed against a wall for maximizing work space
- Independent laser switch Laser marker

Specifications:-

Continuous rating input	1,510W
Blade Diameter	260 mm (10-1/4")
Bevel Angle	48° L / 48° R
Miter Angle	60° L / 60° R
Max Cutting Capacity (Bevel/Miter)	90°/45°LR: 68 / 218 mm 90°/45°LR: 91 / 197 mm
No Load Speed (RPM)	3,200
Dimensions (L x W x H)	805x644x660 mm (31-3/4"x25-3/8"x26")
Net weight	26.3 kg (57.9 lbs.)
Power supply cord	2.5 m (8.2 ft.)

Standard Equipment: Dust Bag, Triangular Rule, Vertical Vise, Hex Wrench

LS1219L 305mm (12")
Acc Pg. A143-161 **153**

Slide Compound Miter Saw (DXT)



Deep and Exact Cutting Technology



Single sliding system enables smooth operation to produce superior cuts

- Large turn base supports workpiece securely for increased stability
- Integrated guide fences for increased rigidity and high cutting accuracy
- Increased dust extraction rate for a cleaner work environment
- Rail-forward design enables to be placed against a wall for maximizing work space
- Independent laser switch Laser marker

Specifications:-



Continuous rating input	1,800W
Blade Diameter	305 mm (12")
Bevel Angle	60° L / 60° R
Miter Angle	48° L / 48° R
Max Cutting Capacity (Bevel/Miter)	90°: 107 x 363 mm (4-1/4" x 14-1/4") 45°: 107 x 255 mm (4-1/4" x 10")
No Load Speed (RPM)	3,200
Dimensions (L x W x H)	898x644x725 mm (35-1/4"x25-3/8"x28-1/2")
Net weight	29.3 kg (64.6 lbs)
Power supply cord	2.5 m (8.2 ft.)

Standard Equipment: Dust Bag, Triangular Rule, Vertical Vise, Hex Wrench

- CORDLESS
- FIXING / FASTENING
- DRILLING / IMPACT DRILLING
- CONCRETE DRILLING / DEMOLITION
- CUTTING (CONCRETE/ MASONRY/ METAL)
- MULTI TOOL
- GRINDING
- SANDING / POLISHING
- SAWING
- ROUTERING / PLANING
- CLEANING
- HEAT GUN / LASERS
- PNEUMATIC TOOLS
- GARDEN TOOLS
- GENERATORS

LS0714
Acc Pg. A146-161 **153**

Slide Compound Miter Saw

Double sliding mechanism makes it lighter and more compact, requiring smaller work space, allowing quick storing and easy transport

- Max cutting capacity 300mm (width) (11-3/4").
- All the four rails ride on a linear ball bearings which creates dual sliding of saw head



Specifications:-

Continuous rating Input	1,010W
Max cutting capacity	at 0 degrees : 52mm x 300mm (2-1/16" x 11-3/4") at 45 degrees : 52mm x 212mm (2-1/16" x 8-3/8")
Blade diameter	190mm (7-1/2")
Blade bore	20mm
No load speed	6,000rpm
Dimensions (L x W x H)	670mm x 430mm x 458mm (26-3/8" x 17" x 18")
Net weight	13.1kg (28.9lbs)
Power supply cord	2.5m (8.2ft)

Standard Equipment: Socket Wrench, Dust Bag, Holder Set, Vertical Vise, Triangular Rule

LS1018LN
Acc Pg. A146-161 **JM23000123**

Slide Compound Miter Saw

Bevel cutting 45 degrees left and right

- Ergonomically designed rubberized soft grip provides more control and comfort
- Laser marker for easy cut line alignment

Specifications:-

Continuous rating Input	1,430W
Max cutting capacity	at 0 degrees : 91 x 305mm (3-5/8" x 12") at 45 degrees : 91 x 215mm (3-5/8" x 8-1/2")
Blade diameter	255 - 260mm (10 - 10-1/4")
Blade bore	15.88 / 30mm (Ring 16)
No load speed (rpm)	4,300
Dimensions (L x W x H)	536 x 825 x 633mm (21-1/8" x 32-1/2" x 25")
Net weight	19.9kg (43.9lbs)
Power supply cord	2.5m (8.2ft)

Standard Equipment: Vertical Vise, Socket Wrench, Triangular Rule, Dust Bag, Holder Assembly

LS0815FL
Acc Pg. A146-161

Slide Compound Miter Saw



High dust extraction for clean work environment

- Max cutting depth of 65mm at 90° and 50mm at 45° bevel left.
- Laser marker for easy cut line alignment.
- Easy bevel angle change from 45° to 48° left and from 0° (right angle) to 5° right with simple operation of a push-button.
- Miter range of 50° left and 60° right with positive stops at 0°, 15°, 22.5°, 31.6°, 45° left/right, 50° left and 60° right

Specifications:-

Continuous rating input	1,400W
Max cutting capacity	at 0 degrees : 65x305mm (2-9/16"x12") at 45 degrees : 50x305mm (2"x12")
Blade diameter	216mm (8-1/2")
No load speed (rpm)	5,000
Dimensions (L x W x H)	755x450x488mm (29-3/4"x17-3/4"x19-1/4")
Net weight	14.1kg (31.1lbs)
Power supply cord	2.5m (8.2ft)

Standard Equipment: Socket wrench, Dust bag, Holder set, Vertical vise, Triangular rule

LS1040
Acc Pg. A146-161 **153**

Compound Miter Saw

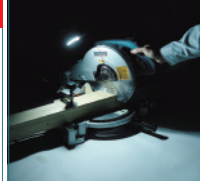
Robust construction for consistently accurate cuts

- Bevel cuts to 45 degrees left
- Pivoting fence provide efficient support to stock

Specifications:-

Continuous rating Input	1,650W
Max cutting capacity	at 0 degrees : 90.5 x 95mm (3-9/16" x 3-3/4") at 45 degrees : 90.5 x 67mm (3-9/16" x 2-5/8")
Blade diameter	255 - 260mm (10" - 10-1/4")
Blade bore	15.88 / 30mm (Ring 16)
No load speed	4,600rpm
Dimensions (L x W x H)	530 x 532 x 476mm (20-7/8" x 21" x 18-3/4")
Net weight	12.4kg (27.3lbs)
Power supply cord	2.5m (8.2ft)

Standard Equipment: Socket Wrench, Dust Bag, Holders 2, Vertical Vise, Triangular Rule

MLS100N 255mm Acc Pg. A146-161

Miter Saw



Compact and robust construction for more accurate cuts

- Same performance, precision and durability as LS1040
- Bevel cuts to 45 degrees left

Specifications:- 

Continuous rating Input	1,500W
Max cutting capacity	at 0 degrees : 75 x 90mm at 45 degrees : 48 x 90mm
Blade diameter	255 mm
No load speed	4,200rpm
Dimensions (L x W x H)	610 x 485 x 515mm
Net weight	14.7kg
Power supply cord	2.5m (8.2ft)

Standard Equipment: Socket Wrench, Dust Bag, Holders 2, Vertical Vise, Triangular Rule

LS1440 355mm (14") Acc Pg. A146-161 **154**

Miter Saw

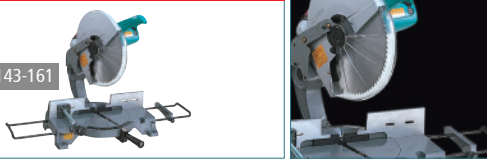

Clean miter cutting up to 45 degrees, right or left

- Self-aligning center plates on the guide fence for less splintering
- Large cutting capacity with 355mm (14") blade

Specifications:- 

Continuous rating Input	1,380W
Max cutting capacity	at 0 degrees : 122 x 152mm (4-13/16" x 6") at 45 degrees : 122 x 115mm (4-13/16" x 4-1/2")
Blade diameter	355mm (14")
Blade bore	25mm
No load speed	3,200rpm
Dimensions (L x W x H)	596 x 530 x 435mm (23-1/2" x 20-7/8" x 17-1/8")
Net weight	34.2kg (75.4lbs)
Power supply cord	2.5m (8.2ft)

Standard Equipment: Socket Wrench, Vise Assembly, Dust Bag, Holder Set

LH1201FL 305mm (12") Acc Pg. A143-161

Table Top Miter Saw



Max. cutting width up to 200mm

- Able to cut two layers of 192mm x thickness 23mm wood floorings in a single stroke
- Sturdy cast aluminum table
- Laser marker allows for easy ink line alignment
- 4 LED job lights provides a clear view of ink line even in dark places when the tool is used as a miter saw

Specifications:- 

Continuous rating Input	1,650W
Max cutting capacity	at 0 degrees : 95 x 155mm (3-3/4" x 6-1/8") at 45 degrees : 64 x 155mm (2-1/2" x 6-1/8")
Blade diameter	305mm (12")
No load speed (rpm)	3,800
Dimensions (L x W x H)	610 x 535 x 692mm (24" x 21" x 27-1/4")
Net Weight	20.7kg (45.6lbs)
Power supply cord	2.5m (8.2ft)

Standard Equipment: Vertical vise, Dust bag, Guide rule, Ring, Triangular rule, Push stick, Blade cover, Socket wrench, Holder set

LH1040 260mm (10-1/4") Acc Pg. A143-161 **153**

Table Top Miter Saw



Miter saw and table saw packed in one tool for great versatility

- Weighs only 14.3kg for easy transport to job sites.
- With sturdy cast aluminum table.
- Anti-restart switch protects user from accidental start.
- Powerful 1,650W motor allows easy rip cutting

Specifications:- 

Continuous rating Input	1,650W
Max cutting capacity	at 0 degrees : 93 x 95mm (3-5/8" x 3-3/4") at 45 degrees : 53 x 95mm (2-1/16" x 3-3/4")
Table saw mode	40mm
Blade diameter	260mm (10-1/4")
Blade bore	15.88 / 30mm (Ring 16)
No load speed	4,800rpm
Dimensions (L x W x H)	530 x 476 x 535mm (20-7/8" x 18-3/4" x 21")
Net weight	14.3kg (31.5lbs)
Power supply cord	2.5m (8.2ft)

Standard Equipment: Rip Fence, Set Plate, Holder, Blade Cover, Push Stick, Socket Wrench, Triangular Rule, Sub Plate Assembly, Dust Bag

- CORDLESS
- FIXING / FASTENING
- DRILLING / IMPACT DRILLING
- CONCRETE DRILLING / DEMOLITION
- CUTTING [CONCRETE/ MASONRY/ METAL]
- MULTI TOOL
- GRINDING
- SANDING / POLISHING
- SAWING
- ROUTERING / PLANING
- CLEANING
- HEAT GUN / LASERS
- PNEUMATIC TOOLS
- GARDEN TOOLS
- GENERATORS

- CORDLESS
- FIXING / FASTENING
- DRILLING / IMPACT DRILLING
- CONCRETE DRILLING / DEMOLITION
- CUTTING [CONCRETE/ MASONRY/ METAL]
- MULTI TOOL
- GRINDING
- SANDING / POLISHING
- SAWING
- ROUTERING / PLANING
- CLEANING
- HEAT GUN / LASERS
- PNEUMATIC TOOLS
- GARDEN TOOLS
- GENERATORS

LF1000 260mm (10-1/4") Acc Pg. A146-161 **153**



Flip Over Saw

Light weight motor enables quick conversion of table and miter saw

- Tough motor ideal for cutting material with load, bevel cut (max. 45 degrees left), cutting thick material.
- Compact fold away legs allow easy transport to job site.
- Rigid cast aluminium table.

Specifications:-

Continuous rating Input	1,650W
Max cutting capacity	at 0 degrees : 20mm x 210mm (13/16" x 8-1/4") at 45 degrees : 50mm x 150mm (2" x 5-7/8")
Table saw mode	70mm
Blade diameter	260mm (10-1/4")
Blade bore	15.88 / 30mm (Ring 16)
No load speed	2,700rpm
Dimensions (L x W x H)	Miter saw : 660 x 650 x 800 (1,220)mm (26" x 25-1/2" x 31 (48)") Table saw : 660 x 650 x 845 (1,060)mm (26" x 25-1/2" x 33-1/4 (41-3/4)")
Net weight	36.0kg (79.4lbs)
Power supply cord	2.5m (8.2ft)

Standard Equipment: Rip Fence, Bevel Guide, Push Stick, Blade Guard, Dust Cover, Dust Bag, Wrench 8

2703 255mm (10") Acc Pg. A146-161 **153**



Table Saw

Smooth precision cutting on a large table; 686 x 560mm (27" x 22")

- Riving knife moves together with saw blade.
- Powerful 1,650W motor.
- Lightweight (18kg) for easy transportation

Specifications:-

Continuous rating Input	1,650W
Max cutting capacity	at 0 degrees : 91mm (3-9/16") at 45 degrees : 63mm (2-1/2")
Blade diameter	255mm (10")
Blade bore	15.88 / 30mm (Ring 16)
No load speed (rpm)	4,600rpm
Dimensions (L x W x H)	686 x 560 x 308mm (27" x 22" x 12-1/8")
Net weight	18.0kg (39.6 lbs)
Power supply cord	2.5m (8.2ft)

Standard Equipment: Rip Fence, Miter Gauge, Offset Wrench, Wrench, Holder Cap Opener

2704N 260mm Acc Pg. A146-161 **153**

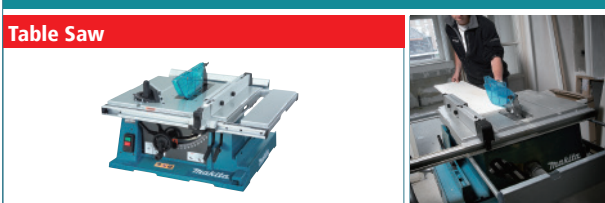

Table Saw

Rigid, precision cutting, high spec table saw

- Machined saw table with high rigidity delivers accurate cutting work.
- Powerful motor enables ripping 4" x 8" wood with telescopic sub table.
- Rip fence with very smooth sliding movement with anti-lifting T-shaped rail.
- Side and rear extension tables available as option

Specifications:-

Continuous rating Input	1,650W
Capacity	at 90° degrees : 91mm at 45° degrees : 63mm
Blade diameter	255mm
Blade bore	15.88 / 25.4mm
No load speed	4,800rpm
Bevel cutting capacity (degrees)	-0.5 - 45.5
Dimensions (L x W x H)	665 x 766 x 344mm
Net weight	34.9kg
Power supply cord	2.5m

Standard Equipment: Rip Fence, Miter Gauge, Wrenches , Push Stick, Ring

MLT100N 260mm Acc Pg. A146-161 **JM230001**

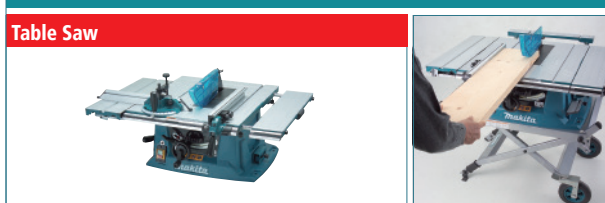

Table Saw

Sliding left extension sub-table is provided

- Right and rear extension table enables greater cutting capacity.
- Safety guard is installable and removable without tool.
- On-tool storage for accessories is provided.

Specifications:-

Continuous rating Input	1,500W
Capacity	at 0 degrees : 91mm (3-9/16") at 45 degrees : 63mm (2-1/2")
Blade diameter	260mm
No load speed (rpm)	4,300
Dimensions (L x W x H)	726 x 984 x 333mm (28-1/2"x38-3/4"x13-1/8")
Net weight	34.1kg (75.2lbs)
Power supply cord	2.5m (8.2ft)

Standard Equipment: Rip Fence, Miter Gauge, Wrenches, Push Stick, Triangular Rule

2712 315mm (12-3/8")

Acc Pg. A146

Table Saw



315mm table saw with induction motor

- Left extension sub-table is provided.
- The table saw installs the connection for vacuum.
- The table saw has two wheel for transportation

Specifications:-



Continuous rating Input	220V: 2,000W / 127V: 1,760W
Max cutting capacity	at 0 degrees : 85mm (3-3/8") at 45 degrees : 58mm (2-1/4")
Blade diameter	315mm (12-3/8")
No load speed (rpm)	50Hz: 2,950 60Hz: 3,400
Bevel cutting capacity (degrees)	0 - 45
Dimensions (L x W x H)	1,670 x 700 x 810mm (65-3/4" x 27-1/2" x 32")
Net weight	52.9kg (116.6lbs)
Power supply cord	3.0m (9.8ft)

Standard Equipment: Rip fence, Miter gauge, Wrenches, Push stick, Extension Table

5800NB 180mm (7-1/8")

Acc Pg. A143-160 **100**

Circular Saw



One of our best-selling portable circular saws

- Double insulation structure

Specifications:-



Continuous rating Input	900W
Capacity	at 0 degrees : 64mm (2-1/2") at 45 degrees : 43mm (1-11/16")
Blade diameter	180mm (7-1/8")
Blade bore	20mm
No load speed	4,500rpm
Overall length	272mm (10-3/4")
Net weight	3.5kg (7.7lbs)
Power supply cord	5.0m (16.4ft)

Standard Equipment: Socket Wrench, Rip Fence (Guide Rule)

5007N 185mm (7-1/4")

Acc Pg. A143-160 **154**

Circular Saw



Designed for all-round easier operation

- Powerful 1,800W motor for heavy duty applications.
- Large wrap-around aluminum base and superb cross cut or rip sawing actions
- Rubberized soft grip provides more comfort and control

Specifications:-



Continuous rating Input	1,800W
Capacity	at 0 degrees : 63.5mm at 45 degrees : 45mm at 56 degrees : 35mm
Blade diameter	185mm (7-1/4")
Blade bore	20mm
No load speed (rpm)	5,800
Overall length	317mm
Net weight	5.2kg(11.5 lbs)
Power supply cord	2.5m (8.2 ft)

Standard Equipment: Hex Wrench, Guide Rule

HS7010 185mm (7-1/4")

Acc Pg. A143-160

Circular Saw



High Power and Increased Motor-Burnout Resistance

- Faster cutting
- High Motor durability
- Powerful 1,600 W motor delivers 5,500 RPM for increased performance and job site durability

Specifications:-



Continuous rating input	1,600W
Blade Diameter	185 / 190 mm
Max Cutting Capacity	0°: 65 / 67 mm 45°: 44 / 45 mm
No Load Speed (RPM)	5,500
Dimensions (L x W x H)	300x240x261 mm
Net weight	4.0 kg (8.9 lbs)
Power supply cord	2.5 m (8.2 ft)

Standard Equipment: Rip Fence (Guide Rule), Hex Wrench, Dust Nozzle

CORDLESS

FIXING / FASTENING

DRILLING / IMPACT DRILLING

CONCRETE DRILLING / DEMOLITION

CUTTING [CONCRETE/ MASONRY/ METAL]

MULTI TOOL

GRINDING

SANDING / POLISHING

SAWING

ROUTERING / PLANING

CLEANING

HEAT GUN / LASERS

PNEUMATIC TOOLS

GARDEN TOOLS

GENERATORS

- CORDLESS
- FIXING / FASTENING
- DRILLING / IMPACT DRILLING
- CONCRETE DRILLING / DEMOLITION
- CUTTING [CONCRETE/ MASONRY/ METAL]
- MULTI TOOL
- GRINDING
- SANDING / POLISHING
- SAWING
- ROUTERING / PLANING
- CLEANING
- HEAT GUN / LASERS
- PNEUMATIC TOOLS
- GARDEN TOOLS
- GENERATORS

N5900B 235mm (9-1/4") Acc Pg. A143-160 **153**

Circular Saw



A hardworking saw with the power to rip through most materials

- Sturdy steel safety cover with industrial durability
- High rigidity of rugged steel base provides stability
- Flat-end motor housing for easy blade changes



Specifications:-

Continuous rating Input	220V: 2,000W / 127V: 1,650W
Capacity	at 0 degrees : 85mm (3-3/8") at 45 degrees : 60mm (2-3/8") at 50 degrees : 53mm (2-1/16")
Blade diameter	235mm (9-1/4")
Blade bore	30 mm
No load speed	4,100rpm
Overall length	380mm (15")
Net weight	7.2kg (15.9lbs)
Power supply cord	2.5m (8.2ft)

Standard Equipment: Guide Rule, Wrench 13

5201N 260mm (10-1/4") Acc Pg. A145-160 **153**

Circular Saw

Ideal for cutting large dimensional timber cleanly and accurately in a single pass

Specifications:-

Continuous rating Input	220V: 1,750W / 127V: 1,650W
Capacity	at 0 degrees : 97mm (3-3/4") at 45 degrees : 64mm (2-1/2")
Blade diameter	260mm (10-1/4")
Blade bore	25mm
No load speed	3,700rpm
Overall length	445mm (17-1/2")
Net weight	8.0kg (17.5lbs)
Power supply cord	5.0m (16.4ft)

Standard Equipment: Wrench, Hex Wrench, Rip Fence (Guide Rule)

HS0600 260 mm / 270 mm Acc Pg. A145-160

Circular Saw



Lightweight and good balance thanks to Magnesium components (7.6 Kg)



Enables single-pass cutting of 89 mm 4x materials

- Enables single-pass cutting of 89 mm 4x materials
- Large cutting capacity 97 mm at 90° with 260 mm blade, 101 mm at 90° with 270 mm blade and bevel capacity (0°-50°)
- Magnesium components create a lightweight saw that is well balanced and job site tough
- Fine parallel adjustment of the base plate to the saw blade
- Compatible with optional guide rail for increased maneuverability

Specifications:-

Continuous rating input	2,000W
Blade Diameter	260 / 270 mm (10-1/4" / 10-5/8")
Max Cutting Capacity	0°: 97 / 101 mm (3-13/16" / 4") 45°: 68 / 71 mm (2-11/16" / 2-13/16") 50°: 61 / 63 mm (2-3/8" / 2-1/2")
No Load Speed (RPM)	4,300
Vibration Level	Cutting Wood: 2.5 m/s² or less
Sound Pressure Level	94 dB(A)
Sound Power Level	105 dB(A)
Dimensions (L x W x H)	418x273x324 mm (16-1/2" x 10-3/4" x 12-3/4")
Net weight	6.9 kg (15.2 lbs)
Power supply cord	2.5 m (8.2 ft)

Enables single-pass cutting of 4X lumber : 89 mm (2/1-3")

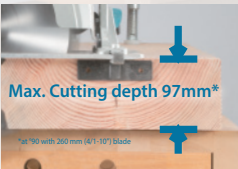

Powerful 2,000W motor

Standard Equipment: Rip Fence (Guide Rule), Hex Wrench

5103N 335mm Acc Pg. A145-160 **153** 

Circular Saw



Huge cutting capacity with efficient control

- Sturdy, rugged performer

Specifications:-

Continuous rating Input	1,750W
Capacity	at 0 degrees : 128mm (5") at 45 degrees : 91mm (3-5/8")
Blade diameter	335mm (13-1/8")
Blade bore	25mm
No load speed	2,900rpm
Overall length	505mm (19-7/8")
Net weight	10.6kg (23.4lbs)
Power supply cord	5.0m (16.4ft)

Standard Equipment: Wrench, Hex Wrench, Rip Fence (Guide Rule)

5143R 355mm Acc Pg. A145-160 **203** 

Circular Saw



355 mm SJS Circular Saw, Electric Brake, Soft Start

- Equipped with SJS (Super Joint System)
- More efficient chip/sawdust ejection
- With anti kickback riving knife
- Two parallel gauge can fix material securely
- Safety cover with roller makes feeding of material smooth and prevents score on surface of material
- Flat-end motor housing for easy blade changes

Specifications:- 

Continuous rating input	2,200W
Blade Diameter	355 mm (14")
Max Cutting Capacity	90°: 130 mm (5-1/8") 45°: 90 mm (3-1/2")
No Load Speed (RPM)	2,700
Overall Length	607 mm (23-7/8")
Net weight	12.5 kg (27.6 lbs.)
Power supply cord	5.0 m (16.4 ft)

Standard Equipment: Hex Wrench, Rip Fence (Guide Rule)

5402 415mm Acc Pg. A145-160 **153** 

Circular Saw



The biggest portable ever

- Yet, surprisingly light at 14kg (30.8lbs) for easy wood cutting
- Cuts 157mm (6-3/16") at 90 degrees and 106mm (4-3/16") at 45 degrees

Specifications:-

Continuous rating Input	1,750W
Capacity	at 0 degrees : 157mm (6-3/16") at 45 degrees : 106mm (4-3/16")
Blade diameter	415mm (16-5/16")
Blade bore	25mm
No load speed	2,200rpm
Overall length	615mm (24-1/4")
Net weight	13.6kg (30.0lbs)
Power supply cord	5.0m (16.4ft)

Standard Equipment: Wrench, Hex Wrench, Rip Fence (Guide Rule)

SP6000 165mm Acc Pg. A143-160 **303** 

Plunge Cut Circular Saw

*** To be used with guide Rail**



High accurate, clean cutting.

- Tip-resistant design
- Depth stopper enables to easily cut a preliminary groove at a depth of 2mm (1/16") for splinter-free cuts.
- The position of cutting line is always the same regardless of bevel angle in cutting with guide rail attached.
- Close-to-wall cutting only 18mm (11/16") away from wall at minimum.
- Bevel cut -1 to 48 degrees

Specifications:- 

Continuous rating Input	1,300W
Capacity	at 0 degrees : 56mm (2-3/16") at 45 degrees : 40mm (1-9/16") at 48 degrees : 38mm (1-1/2")
Blade diameter	165mm (6-1/2")
Blade bore	20mm
No load speed (rpm)	2,000 - 5,200
Dimensions (L x W x H)	341 x 225 x 250mm (13-3/8" x 8-7/8" x 9-7/8")
Net weight	4.4kg (9.7lbs)
Power supply cord	2.5m (8.2ft)

Standard Equipment: Hex Wrench, Guide Rule (Tool does not comes with guide rail)

CORDLESS

FIXING / FASTENING

DRILLING / IMPACT DRILLING

CONCRETE DRILLING / DEMOLITION

CUTTING [CONCRETE/ MASONRY/ METAL]

MULTI TOOL

GRINDING

SANDING / POLISHING

SAWING

ROUTERING / PLANING

CLEANING

HEAT GUN / LASERS

PNEUMATIC TOOLS

GARDEN TOOLS

GENERATORS

- CORDLESS
- FIXING / FASTENING
- DRILLING / IMPACT DRILLING
- CONCRETE DRILLING / DEMOLITION
- CUTTING [CONCRETE/ MASONRY/ METAL]
- MULTI TOOL
- GRINDING
- SANDING / POLISHING
- SAWING
- ROUTERING / PLANING
- CLEANING
- HEAT GUN / LASERS
- PNEUMATIC TOOLS
- GARDEN TOOLS
- GENERATORS

4300BA
Acc Pg. A152-161 **51**

Jig Saw



Long-run best seller, this tool puts performance first

- Bevel cuts up to 45 degrees right or left
- Full 26mm (1") stroke length.



Specifications:- 

Continuous rating Input	390W
Capacity	In wood at 0 degrees : 55mm (2-1/8") In steel at 90 degrees : 6mm (1/4")
Length of stroke	26mm (1")
Strokes per min.	3,100
Overall length	225mm (8-7/8")
Net weight	2.5kg (5.5lbs)
Power supply cord	2.5m (8.2ft)

Standard Equipment: Rip Fence (Guide Rule), Circular Guide Assembly, Blade Clamp Assembly, Hex Wrench

4300BV
Acc Pg. A152-161 **51**

Jig Saw

Long-run best seller, this tool puts performance first

- Bevel cuts up to 45 degrees right or left
- Full 26mm (1") stroke length
- Variable speed feature

Specifications:- 

Continuous rating Input	390W
Capacity	In wood at 0 degrees : 55mm (2-1/8") In steel at 90 degrees : 6mm (1/4")
Length of stroke	26mm (1")
Strokes per min.	0-3,100
Overall length	225mm (8-7/8")
Net weight	2.5kg (5.5lbs)
Power supply cord	2.5m (8.2ft)

Standard Equipment: Rip Fence (Guide Rule), Circular Guide Assembly, Blade Clamp Assembly, Hex Wrench

4326
Acc Pg. A152-160 **64**

Jig Saw



Light duty model with continuous input 450W

- Ergonomically designed handle with rubberized grip provides more control and comfort
- Thick blade (1.7mm thickness) can also be used
- Dust Cover prevents scattering of tips
- Bevel cut 0 to 45 degrees left or right
- Quiet and less vibration

Specifications:- 

Continuous rating Input	450W
Capacity	In wood at 0 degrees : 65mm (2-9/16") In steel at 90 degrees : 6mm (1/4")
Length of stroke	18mm (11/16")
Strokes per minute (spm)	3,100
Dimensions (L x W x H)	224 x 77 x 197mm (8-7/8" x 3" x 7-3/4")
Net weight	1.8kg (4.0lbs)
Power supply cord	2.0m (6.6ft)

Standard Equipment: Hex Wrench

4327
Acc Pg. A152-160 **64**

Jig Saw



Light duty model with continuous input 450W

- Ergonomically designed handle with rubberized grip provides more control and comfort
- Thick blade (1.7mm thickness) can also be used
- Dust Cover prevents scattering of tips
- Bevel cut 0 to 45 degrees left or right
- Quiet and less vibration
- Variable speed feature

Specifications:- 

Continuous rating Input	450W
Capacity	In wood at 0 degrees : 65mm (2-9/16") In steel at 90 degrees : 6mm (1/4")
Length of stroke	18mm (11/16")
Strokes per minute (spm)	500 - 3,100
Dimensions (L x W x H)	224 x 77 x 197mm (8-7/8" x 3" x 7-3/4")
Net weight	1.8kg (4.0lbs)
Power supply cord	2.0m (6.6ft)

Standard Equipment: Hex Wrench

4329 Acc Pg. A152-160 **64**

Jig Saw



Light duty model with continuous input 450W

- 3 orbital settings plus straight cutting
- Variable speed control dial (500-3,100 SPM) enables user to match the speed to the application for optimal cutting performance in a variety of materials.
- Through-the-body dust port provides optimal dust management with use of clear dust cover and vacuum.
- Bevel cuts to 45° right or left and positive stop at 90° for solid cutting performance

Specifications:-

Continuous rating Input	450W
Capacity	In wood at 0 degrees : 65mm (2-9/16") In steel at 90 degrees : 6mm (1/4")
Length of stroke	18mm (11/16")
Strokes per minute (spm)	500 - 3,100
Dimensions (L x W x H)	224 x 77 x 197mm (8-7/8" x 3" x 7-3/4")
Net weight	1.8kg (4.0lbs)
Power supply cord	2.0m (6.6ft)

Standard Equipment: Hex Wrench

4350CT Acc Pg. A152-160 **419**

Jig Saw



Tool less blade change system (with electronic control + speed dial)

- Electronic speed control maintains consistent speed set for various work piece
- 3 orbital settings plus straight cut
- Plastic cover plate can be attached without tool
- Low vibration and low noise level

Specifications:-

Continuous rating Input	720W
Capacity	In wood at 90 degrees : 135mm (5-5/16") In steel at 90 degrees : 10mm (3/8")
Length of stroke	26mm (1")
Strokes per minute	800 - 2,800 spm
Dimensions (L x W x H)	236 x 73 x 207mm (9-1/4" x 2-7/8" x 8-1/8")
Net weight	2.4kg (5.3lbs)
Power supply cord	2.5m (8.2ft)

Standard Equipment: Hex Wrench, Cover Plate, Anti-Splintering Device

4350FCT Acc Pg. A152-160 **419**

Jig Saw



Tool less blade change system (with electronic control + speed dial)

- Electronic speed control maintains consistent speed set for various work piece
- 3 orbital settings plus straight cut
- Plastic cover plate can be attached without tool
- Low vibration and low noise level
- Built-in LED job light for easy tracing of cutting line

Specifications:-

Continuous rating Input	720W
Capacity	In wood at 90 degrees : 135mm (5-5/16") In steel at 90 degrees : 10mm (3/8")
Length of stroke	26mm (1")
Strokes per minute	800 - 2,800 spm
Dimensions (L x W x H)	236 x 73 x 207mm (9-1/4" x 2-7/8" x 8-1/8")
Net weight	2.4kg (5.3lbs)
Power supply cord	2.5m (8.2ft)

Standard Equipment: Hex Wrench, Cover Plate, Anti-Splintering Device

4351FCT Acc Pg. A152-160 **419**

Jig Saw



Toolless blade change system (with electronic control + speed dial)

- Electronic speed control maintains consistent speed set for various work piece
- 3 orbital settings plus straight cut
- Built-in LED job light for easy tracing of cutting line.
- Ergonomically designed handle with soft grip provides more control and comfort.
- Low vibration and low noise level

Specifications:-

Continuous rating input	720W
Capacity	Wood : 135mm (5-5/16") Steel : 10mm (3/8")
Length of stroke	26mm (1")
Strokes per minute (spm)	800 - 2,800
Dimensions (L x W x H)	271x73x187mm (10-11/16" x 2-7/8" x 7-3/8")
Net weight	2.5kg (5.5lbs)
Power supply cord	2.5m (8.2ft)

Standard Equipment: Hex wrench, Cover plate, Anti-splintering device

CORDLESS

FIXING / FASTENING

DRILLING / IMPACT DRILLING

CONCRETE DRILLING / DEMOLITION

CUTTING [CONCRETE/ MASONRY/ METAL]

MULTI TOOL

GRINDING

SANDING / POLISHING

SAWING

ROUTERING / PLANING

CLEANING

HEAT GUN / LASERS

PNEUMATIC TOOLS

GARDEN TOOLS

GENERATORS

- CORDLESS
- FIXING / FASTENING
- DRILLING / IMPACT DRILLING
- CONCRETE DRILLING / DEMOLITION
- CUTTING (CONCRETE/ MASONRY/ METAL)
- MULTI TOOL
- GRINDING
- SANDING / POLISHING
- SAWING
- ROUTERING / PLANING
- CLEANING
- HEAT GUN / LASERS
- PNEUMATIC TOOLS
- GARDEN TOOLS
- GENERATORS

SJ401
Acc Pg. A158

Scroll Saw



Bevel cuts up to 45 degrees to the left and 15 degrees to the right

- Tool-free blade change system
- Quick adjustment of blade tension thanks to blade tension lever
- Sturdy cast iron base for stability and less-vibration cutting

Specifications:- 

Continuous rating Input	50W
Capacity	Thickness of cut : 50mm (2") Throat : 406mm (16")
Length of stroke	18mm (11/16")
Strokes per min.	400-1,600 spm
Overall length	600mm (23-5/8")
Net weight	14.1kg (31lbs)

Standard Equipment: Saw Blades 6, Hex Wrench, Blade Change Rod

JR1000FT
Acc Pg. A155-157 **419**

Recipro Saw / Inline Jig Saw



Small and lightweight body

- All B type jigsaw blades can fit in this saw
- Accessories for sanding and filing are also available
- Tool-less blade change system
- Variable speed for precise cutting in a wide variety of materials
- With LED job light

Specifications:- 

Continuous rating Input	340W
Capacity	In pipe : 25.4mm (1") In wood : 55mm (2-3/16")
Length of stroke	14mm (9/16")
Strokes per min (spm)	0-4,800
Dimensions (L x W x H)	345 x 65 x 96mm (13-5/8" x 2-9/16" x 3-3/4")
Net weight	1.6kg (3.5lbs)

Standard Equipment: No. B8-, B10-, B30- (each 1 pc.) , Hex Wrench

JR3050T
Acc Pg. A156-157 **303**

Recipro Saw, Orbital

Well built and well balanced mid-class

- High cutting efficiency by powerful motor
- Dust proof design 1 : Air from inside prevent the dust to be collected around slider
- Dust proof design 2 : Ring, and rubber seal protect gear housing against dust
- Tool-less blade change system
- Push the red button to adjust shoe positions

Specifications:- 

Continuous rating Input	1,010W
Capacity	In pipe : 130mm (5-1/8") In wood : 255mm (10")
Length of stroke	28mm (1-1/8")
Strokes per min (spm)	0-2,800
Dimensions (L x W x H)	452 x 97 x 170mm (17-3/4" x 3-13/16" x 6-11/16")
Net weight	3.3kg (7.3lbs)
Power supply cord	2.5m (8.2ft)

Standard Equipment: Recipro Saw Blade Set

JR3051T
Acc Pg. A156-157 **303**

Recipro Saw, Orbital



High power, more compact and high durability

- Delivers superior power and performance with less vibration
- Smooth Cutting in wood and metal applications
- Increased durability achieved by changing the slider holding mechanism
- Dust proof design 2 : Ring, and rubber seal protect gear housing against dust
- Tool-less blade change system
- Push the red button to adjust shoe positions

Specifications:- 

Continuous rating input	1,200W
Capacity	Pipe : 130 mm (3-1/2") Wood: 255 mm (10")
Length of Stroke	30 mm (1-3/16")
Strokes Per Minute (SPM)	0 - 3,000
Dimensions (L x W x H)	447x97x176 mm
Net weight	3.3 kg
Power supply cord	2.5 m

Standard Equipment: Recipro Saw Blade Set

JR3060T Acc Pg. A156-157 **303**



Robust body with power for heavy-duty operation

- Orbital action : Selectable from 3 degrees for faster cutting in thick materials
- Powerful motor for tough jobs
- All the other features same as JR3050T

Continuous rating Input	1,250W
Capacity	In pipe : 130mm (5-1/8") In wood : 255mm (10")
Length of stroke	32mm (1-1/4")
Strokes per min (spm)	0-2,800
Dimensions (L x W x H)	485 x 99 x 181mm (19-1/8" x 3-7/8" x 7-1/8")
Net weight	4.4kg (9.6lbs)
Power supply cord	2.5m (8.2ft)

Standard Equipment: Recipro Saw Blade (3pcs.)

JR3070CT Acc Pg. A156-157 **303**



Extra-low vibration and extra power

- Feel its comfort with this machine featuring AVT ; counter weight mechanism which helps to reduce vibration
- Makita's top-end powerful reciprocating saw
- Preset dial for speed control for optimal stroke speed for application

Continuous rating Input	1,510W
Capacity	In pipe : 130mm (5-1/8") In wood : 255mm (10")
Length of stroke	32mm (1-1/4")
Strokes per min (spm)	0-2,800
Dimensions (L x W x H)	485 x 99 x 181mm (19-1/8" x 3-7/8" x 7-1/8")
Net weight	4.6kg (10.0lbs)
Power supply cord	2.5m (8.2ft)

Standard Equipment: Recipro Saw Blade (3pcs.)

2107FK Acc Pg. A158 **303**



Large 4-3/4" x 4-3/4" capacity with excellent tool balance

- Bridge construction of aluminum frame and motor housing makes the machine more durable
- Built-in fluorescent job light for clear view of ink line even in dark places
- Switch for fluorescent job light is independent of main switch
- Preset dial for speed adjustment enables you to obtain suitable cutting speed for each material

Continuous rating Input	710W
Capacity	Round work piece (dia.): 120mm (4-3/4") Rectangular work piece (Without stand): 120 x 120mm (4-3/4" x 4-3/4")
Blade speed	60m (200 ft) - 105m (350 ft) /min
Dimensions (L x W x H)	508 x 188 x 256mm
Net weight	6.0kg (13.1lbs)
Power supply cord	2.5m (8.2ft)

Standard Equipment: Hex. Wrench

LB1200F Acc Pg. A158 **419**



High efficiency

- Job light is convenient in dark place
- Easy to replace bandsaw blade by one touch lever
- Dust box is provided
- Easy to move with casters

Continuous rating Input	900W
Capacity	Thickness of cut : 165mm (6-1/2") Throat : 305mm (12")
Blade speed	Hi : (50Hz)800 (60Hz)1,000m ((50Hz)2,624 (60Hz) 3,280ft) / min Lo : (50Hz)400 (60Hz)500m ((50Hz)1,312 (60Hz) 1,640ft) / min
Dimensions (L x W x H)	615 x 775 x 1,600mm
Net weight	(24-1/4" x 30-1/2" x 63") 81.2kg (179.0lbs)
Power supply cord	2.5m (8.2ft)

Standard Equipment: Rip Fence, Angle Rule, Push Stick, Hex Wrench

- CORDLESS
- FIXING / FASTENING
- DRILLING / IMPACT DRILLING
- CONCRETE DRILLING / DEMOLITION
- CUTTING [CONCRETE/ MASONRY/ METAL]
- MULTI TOOL
- GRINDING
- SANDING / POLISHING
- SAWING
- ROUTERING / PLANING
- CLEANING
- HEAT GUN / LASERS
- PNEUMATIC TOOLS
- GARDEN TOOLS
- GENERATORS

Routing / Planing

Power Planer, Router, Trimmer, Sash Router

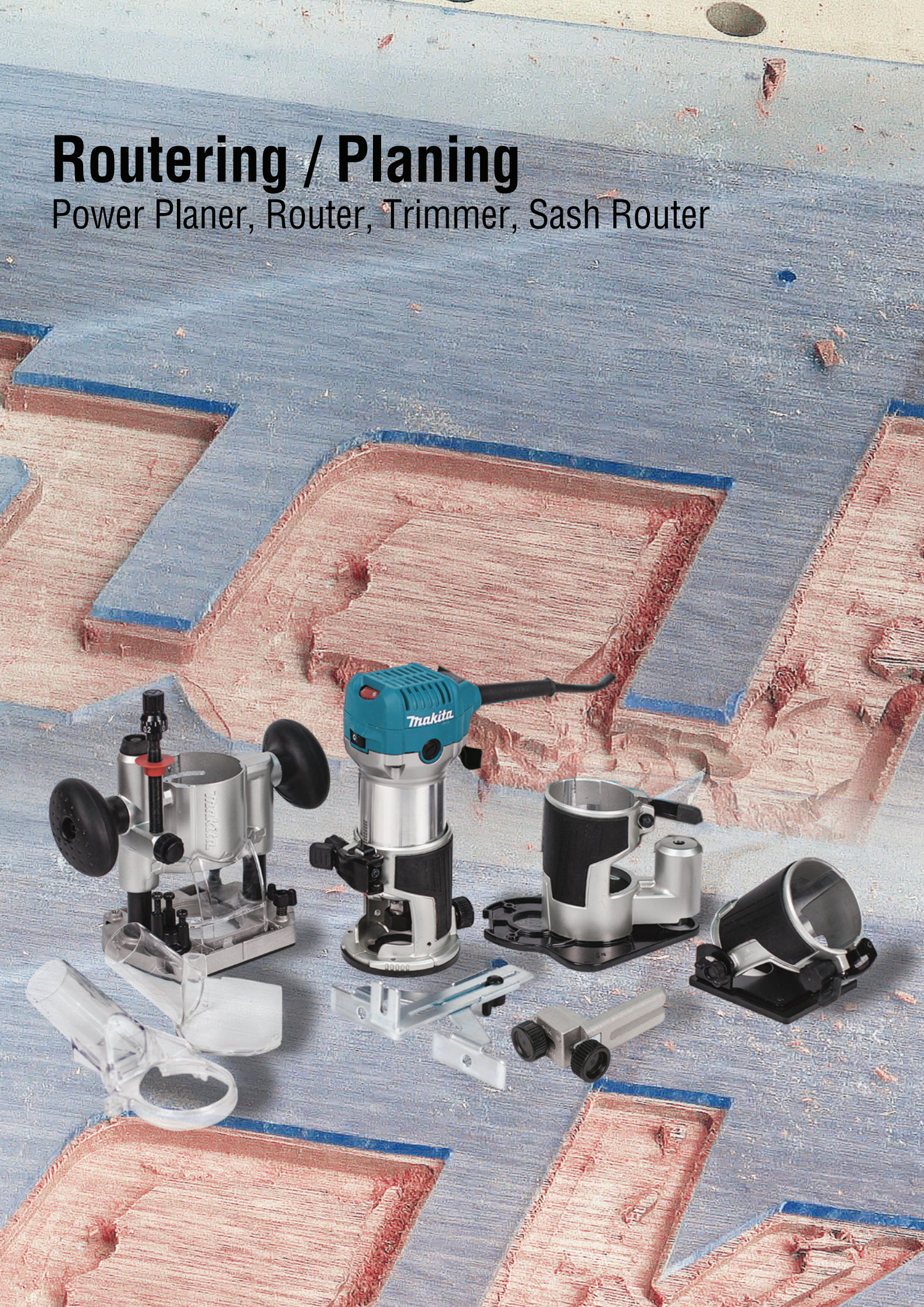



1100 82mm (3-1/4") Acc Pg. A182-184 **100** 

Power Planer



Field-proven, reliable performance from handy and lightweight body

- Wide swath of 82mm (3-1/4"), long rear shoe and handy edge fence

Specifications:-   

Continuous rating Input	750W
Planing width	82mm (3-1/4")
Planing depth	3mm (1/8")
No load speed	16,000rpm
Overall length	415mm (16-3/8")
Net weight	5.1kg (11.2lbs)
Power supply cord	5.0m (16.4ft)

Shiplapping	20mm (3/4")
-------------	-------------

Standard Equipment: Blade Gauge Assembly, Socket Wrench, Edge Fence (Guide Rule).



1902 82mm (3-1/4") Acc Pg. A182-184 **51** 

Power Planer



Ergonomic design for fatigue-free operation

- Can be used with both standard HSS planer blades and double-edged mini TCT blades.
- Simple blade setting system for fast blade installation

Specifications:-  

Continuous rating Input	580W
Planing width	82mm (3-1/4")
Planing depth	1mm (1/32")
No load speed	16,000rpm
Overall length	290mm (11-3/8")
Net weight	2.5kg (5.5lbs)
Power supply cord	2.5m (8.2ft)

Shiplapping	9mm (11/32")
-------------	--------------

Standard Equipment: Blade Gauge Assembly, Socket Wrench

N1900BK 82mm (3-1/4") Acc Pg. A182-184 **51** 

Power Planer



High power-to-weight ratio for superior performance

- Can be used with both standard HSS planer blades and double-edged mini TCT blades.
- Simple blade setting system for fast blade installation.

Specifications:-   

Continuous rating Input	580W
Planing width	82mm (3-1/4")
Planing depth	1mm (1/32")
No load speed	16,000rpm
Overall length	290mm (11-3/8")
Net weight	2.8kg (6.1lbs)
Power supply cord	2.5m (8.2ft)

Shiplapping	9mm (11/32")
-------------	--------------

Standard Equipment: Blade Gauge Assembly, Socket Wrench, Edge Fence (Guide Rule).

N1923BK 82mm (3-1/4") Acc Pg. A182-184 **51** 

Power Planer

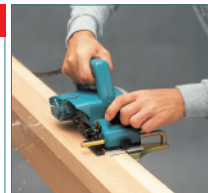

Ideal for shiplapping cuts

- Lightweight and excellent balance.
- Can be used with both standard HSS planer blades and double-edged mini TCT blades.
- Simple blade setting system for fast blade installation.

Specifications:-   

Continuous rating Input	600W
Planing width	82mm (3-1/4")
Planing depth	1mm (1/32")
No load speed	16,000rpm
Overall length	293mm (11-1/2")
Net weight	3.1kg (6.8lbs)
Power supply cord	2.5m (8.2ft)

Shiplapping	23mm (29/32")
-------------	---------------

Standard Equipment: Blade Gauge Assembly, Socket Wrench, Edge Fence (Guide Rule).

CORDLESS

FIXING / FASTENING

DRILLING / IMPACT DRILLING

CONCRETE DRILLING / DEMOLITION

CUTTING [CONCRETE/ MASONRY/ METAL]

MULTI TOOL

GRINDING

SANDING / POLISHING

SAWING

ROUTERING / PLANING

CLEANING

HEAT GUN / LASERS

PNEUMATIC TOOLS

GARDEN TOOLS

GENERATORS

- CORDLESS
- FIXING / FASTENING
- DRILLING / IMPACT DRILLING
- CONCRETE DRILLING / DEMOLITION
- CUTTING [CONCRETE/ MASONRY/ METAL]
- MULTI TOOL
- GRINDING
- SANDING / POLISHING
- SAWING
- ROUTERING / PLANING
- CLEANING
- HEAT GUN / LASERS
- PNEUMATIC TOOLS
- GARDEN TOOLS
- GENERATORS

KP0800XK
82mm (3-1/4")
Acc Pg. A182-184 **411**

Power Planer



Angle and shape of handle are easy to grip, push and carry

- Built-Precise planing depth setting by adjustment knob with click stops.
- Deep planing.

Specifications:-   

Continuous rating Input	620W
Planing width	82mm (3-1/4")
Planing depth	2.5mm (3/32")
No load speed (rpm)	17,000
Dimensions (L x W x H)	285 x 158 x 158mm (11-1/4" x 6-1/4" x 6-1/4")
Net weight	2.6kg (5.7lbs)
Power supply cord	2.5m (8.2ft)
Shiplapping	9mm (11/32")

Standard Equipment: Blade Gauge Assembly, Guide Rule, Planer Blade, Socket Wrench

KP0810K
82mm (3-1/4")
Acc Pg. A182-184 **132**

Power Planer



Lightweight design for easy handling

- Chip ejection switchable to either side depending on conditions.
- Ergonomically designed handle with rubberized grip provides more control and comfort.
- Front base with 3 chamfering grooves.
- Foot on base protects blades if accidentally put down on surface while blades are still rotating.
- Precise depth adjustment knob.

Specifications:-   

Continuous rating Input	850W
Planing width	82mm (3-1/4")
Planing depth	4mm (5/32")
No load speed	16,000rpm
Dimensions (L x W x H)	290 x 168 x 176mm (11-3/8" x 6-5/8" x 6-15/16")
Net weight	3.3kg (7.3lbs)
Power supply cord	2.5m (8.2ft)
Shiplapping	25mm (1")

Standard Equipment: Blade Gauge Assembly, Guide Rule, Planer Blade, Socket Wrench

1911B
110mm (4-3/8")
Acc Pg. A182-184 **106**

Power Planer



Planes up to 110mm (8/3-4") wide and 2mm (1/16") deep in a single pass

- Powerful 840W motor in compact and lightweight body (4.2kg /9.3lbs).



Specifications:-  

Continuous rating Input	840W
Planing width	110mm (4-3/8")
Planing depth	2mm (1/16")
No load speed	16,000rpm
Overall length	355mm (14")
Net weight	4.3kg (9.5lbs)
Power supply cord	5.0m (16.4ft)

Standard Equipment: Blade Gauge Assembly, Guide Rule, Planer Blade, Socket Wrench



1805N
155mm (6-1/8")
Acc Pg. A182-184 **153**

Power Planer

Rugged aluminium housing and easy depth settings.

- Planes up to 155mm (6-1/8") wide and 2mm (1/16") deep in a single pass
- Precision machined aluminium base for planing accuracy

Specifications:-  

Continuous rating Input	1,140W
Planing width	155mm (6-1/8")
Planing depth	2mm (1/16")
No load speed	15,000rpm
Overall length	445mm (17-1/2")
Net weight	8.2kg (18.0lbs)
Power supply cord	5.0m (16.4ft)

Standard Equipment: Blade Gauge Assembly, Guide Rule, Planer Blade, Socket Wrench

2012NB 304mm (12") Acc Pg. A182-184 **153** 

Planer / Thicknesser



Compact and lightweight for easier transport

- Unique feeding mechanism assures smoother finish with minimal snip on stock
- 4-post design and diagonal cross supports for stability

Specifications:- 

Continuous rating Input	1,650W
Cutting width	304mm (12")
Cutting depth	Cutting width 0-150 mm : 3mm (1/8") Cutting width 150-240 mm : 1.5mm (1/16")
Feed rate/min.	8.5m (27.9ft)
Table size (W x L)	304 x 771mm (12" x 30-3/8")
No load speed	8,500rpm
Overall dimensions (L x H x W)	483mm x 771mm x 401mm (19" x 30-3/8" x 15-13/16")
Net weight	28.1kg (61.9lbs)
Power supply cord	2.5m (8.2ft)

Standard Equipment: Socket Wrench, Hex Wrench



PJ7000 82mm (3-1/4") Acc Pg. A185 **459** 

Plate Joiner



Compact and lightweight design for high maneuverability and easy handling

- New design with cast aluminum parts in silver and slim motor housing with an extra-ergonomic barrel grip.
- New top handle with flat shape on side surface for excellent tool control.

Specifications:-   

Continuous rating Input	701W
Blade diameter	100mm (4")
No load speed (rpm)	11,000
Dimensions (L x W x H)	302x139x145mm (11-7/8"x5-1/2"x5-3/4")
Net weight	2.5kg (5.6lbs)
Power supply cord	2.5m (8.2ft)

Standard Equipment: Angle Guide, Dust Bag, Set Plate, Lock Nut Wrench

RT0700C 6mm (1/4"), 8mm (3/8") Acc Pg. A163-181 **411** 

Trimmer



Aluminum housing and base for higher durability and accuracy

- Able to meet a wide range of needs with the motor unit and the following various attachments (Trimmer base, Plunge base, Tilt base, Offset base).
- Flat-top design and Horizontally installed power supply cord provides stability for easier bit change.
- Cutting speed is variably adjustable to suit applications and workpiece materials.

Specifications:-    

Continuous rating Input	710W
Capacity	Collet : 6mm, 8mm or 1/4", 3/8"
No load speed (rpm)	10,000 - 30,000
Dimensions (L x W x H)	89x89x200mm (3-1/2"x3-1/2"x7-7/8")
Net Weight	1.8kg (3.9lbs)
Power supply cord	2.5m (8.2ft)

Standard Equipment: Trimmer Base Assembly, Straight Guide, Wrench (2 pcs)

3700B 6mm (1/4") Acc Pg. A163-181 **51** 

Trimmer



For trimming laminates, wood veneers and more

- Eliminates the need for many secondary finishing works
- Compact and lightweight for easy one-handed operation

Specifications:- 

Continuous rating Input	440W
Capacity	Collet : 6mm or 1/4"
Base	82mm x 90mm (3-1/4" x 3-1/2")
No load speed	28,000rpm
Overall height	195mm (7-5/8")
Net weight	1.6kg (3.5lbs)
Power supply cord	2.5m (8.2ft)

Standard Equipment: Trimmer Guide Assembly, Straight Guide Assembly, Template Guide, Wrenches 2

CORDLESS

FIXING / FASTENING

DRILLING / IMPACT DRILLING

CONCRETE DRILLING / DEMOLITION

CUTTING [CONCRETE/ MASONRY/ METAL]

MULTI TOOL

GRINDING

SANDING / POLISHING

SAWING

ROUTERING / PLANING

CLEANING

HEAT GUN / LASERS

PNEUMATIC TOOLS



GARDEN TOOLS

GENERATORS

- CORDLESS
- FIXING / FASTENING
- DRILLING / IMPACT DRILLING
- CONCRETE DRILLING / DEMOLITION
- CUTTING [CONCRETE/ MASONRY/ METAL]
- MULTI TOOL
- GRINDING
- SANDING / POLISHING
- SAWING
- ROUTERING / PLANING
- CLEANING
- HEAT GUN / LASERS
- PNEUMATIC TOOLS
- GARDEN TOOLS
- GENERATORS

3709 6mm (1/4") Acc Pg. A163-181 **411**

Trimmer

Smooth and precision depth adjustment with rackand pinion mechanism

- Rubberized soft grip provides comfort and control
- Transparent plastic base for clear view of trimming edge

Specifications:-

Continuous rating Input	530W
Capacity	Collet : 6mm or 1/4"
No load speed (rpm)	30,000
Dimensions (L x W x H)	82x90x199mm (3-1/4"x3-1/2"x7-7/8")
Net weight	1.5kg (3.3lbs)
Power supply cord	2.5m (8.2ft)

Standard Equipment: Trimmer Guide Assembly, Straight Guide Assembly, Template Guide, Wrenches 2

RP0900 6mm (1/4") Acc Pg. A163-181 **106**

Router (Plunge type)



High durability and good design router

- 0-35mm(0-1/8") plunge depth capacity with 3 adjustable depth stops for repetitive depth routing
- Scale level for adjusting the depth of routing



Specifications:-

Continuous rating Input	900W
Capacity	Collet : 8mm or 3/8"
Base	145 x 110mm (5-3/4" x 4-5/16")
No load speed (rpm)	27,000
Dimensions (L x W x H)	256 x 110 x 217mm (10-3/32" x 4-5/16" x 8-17/32")
Net weight	2.7kg (6.0lbs)
Power supply cord	2.5m (8.2ft)

Standard Equipment: Straight Guide, Wrenches

3601B 12mm (1/2") Acc Pg. A163-181 **153**

Router

Fine power-to-weight ratio in this well-balanced router

- Non-marring base for excellent finish

Specifications:-

Continuous rating Input	930W
Capacity	Collet : 12mm or 1/2"
Base dia.	160mm (6-1/4")
No load speed	23,000rpm
Overall height	190mm (7-1/2")
Net weight	3.6kg (7.9lbs)
Power supply cord	5.0m (16.4ft)

Standard Equipment: Trimmer Guide Assembly, Straight Guide Assembly, Template Guide, Wrenches 2

3612BR 12mm (1/2") Acc Pg. A163-181 **153**

Router (Plunge type)



Faster, more accurate, more powerful routing

- Large plunge capacity 0-65mm for easy penetration into or through workpiece

Specifications:-

Continuous rating Input	1,600W
Capacity	Collet : 12mm or 1/2"
Plunge capacity	0 - 65mm (0 - 2-9/16")
Base dia.	160mm (6-1/4")
No load speed	23,000rpm
Overall height	287mm (11-1/4")
Net weight	5.5kg (12.0lbs)
Power supply cord	2.5m (8.2ft)

Standard Equipment: Trimmer guide, Straight guide, Template guide, Guide holder, Collet sleeve (6mm or 1/4"), Collet sleeve (8mm or 3/8"), Wrench x2, Straight bit (carbide-tipped)

RP1800 12mm (1/2") Acc Pg. A163-181 **203**

Router (Plunge type)



Powerful motor delivers smooth routing

- Precise cutting depth adjustment.
- Ergonomically contoured knob style handles fit operator's hands perfectly.
- Linear ball bearing for super-smooth plunge action.
- Increased durability obtained by using larger size ball bearing on the drive-end of armature, labyrinth type retainers and fun

Specifications:-

Continuous rating Input	1,850W
Capacity	Collet : 12mm or 1/2"
Plunge capacity	0 - 70mm (0 - 2-3/4")
Base dia.	170mm (6-11/16")
No load speed (rpm)	22,000
Dimensions	155 x 294 x 312mm
(L x W x H)	(6-1/8" x 11-5/8" x 12-1/4")
Net weight	6.0kg (13.2lbs)
Power supply cord	2.5m (8.2ft)

Standard Equipment: Straight Guide, Wrench, Screw M6x135

RP2300FC 12mm (1/2") Acc Pg. A163-181 **203**

Router (Plunge type)



Powerful motor delivers smooth routing

- Precise cutting depth adjustment.
- Ergonomically contoured knob style handles fit operator's hands perfectly.
- Twin LED job lights with afterglow function.
- Linear ball bearing for super-smooth plunge action.
- Increased durability obtained by using larger size ball bearing on the drive-end of armature, labyrinth type retainers and fun.

Specifications:-

Continuous rating Input	220V: 2,300W / 127V: 1,650W
Capacity	Collet : 12mm or 1/2"
Plunge capacity	0 - 70mm (0 - 2-3/4")
Base	170 x 155mm (6-11/16" x 6-1/8")
No load speed (rpm)	9,000 - 22,000
Dimensions	155 x 294 x 312mm
(L x W x H)	(6-1/8" x 11-5/8" x 12-1/4")
Net weight	6.1kg (13.4lbs)
Power supply cord	2.5m (8.2ft)

Standard Equipment: Straight Guide, Wrench, Screw M6 x 135

3706 6.35mm (1/4") Acc Pg. A186 **64**

Cut-out Tool



Optimum for work of cutting plasterboard such as making holes for electric outlets

- Ergonomically designed slim motor housing for superior handling.
- Unrivalled cutting speed.
- Large spindle lock button for quick bit changes

Specifications:-

Continuous rating Input	550W
Capacity	Collet : 3.18mm (1/8") or 6.35mm (1/4")
No load speed	32,000rpm
Overall height	250mm (9-7/8")
Net weight	1.1kg (2.4lbs)
Power supply cord	3.0m (10ft)

Standard Equipment: Wrench 17, Wrench Holder

4403 6mm (1/4") Acc Pg. A177-181 **411**

Sash Router



Mills and drills aluminium for sashes.

- Trimmer model 3709 used as motor unit.
- Large transparent chip guard for operator's safety.
- Base travels side to side.
- Base travels forward and backward.

Specifications:-

Continuous rating Input	530W
Capacity	Collet : 6mm or 1/4"
Max. width of work	123mm (4-7/8")
Max. width at 45 degrees	77mm (3")
Max. height of work	185mm (7-1/4")
Base transv. travel	113mm (4-1/2")
Base longit. travel	73mm (2-7/8")
No load speed	30,000rpm
Overall dimensions	327mm x 350mm x 355mm
(L x H x W)	(12-7/8" x 13-13/16" x 14")
Net weight	16.0kg (35.3lbs)
Power supply cord	2.5m (8.2ft)

Standard Equipment: Angle Gauge, Wrenches 2,

CORDLESS

FIXING / FASTENING

DRILLING / IMPACT DRILLING

CONCRETE DRILLING / DEMOLITION

CUTTING [CONCRETE/ MASONRY/ METAL]

MULTI TOOL

GRINDING

SANDING / POLISHING

SAWING

ROUTERING / PLANING

CLEANING

HEAT GUN / LASERS

PNEUMATIC TOOLS

GARDEN TOOLS

GENERATORS

Cleaning

Vacuum Cleaners, Backpack Vacuum Cleaners, Upright Cleaner, Robotic Cleaner, Stick Type Cleaners, High Pressure Washer



Growing Concern About Dust Hazards to Health

Recently more and more people are showing their stronger interest in hazards dusts which may cause the sickness of the nose, throat, lungs and skin. Some fine dusts may cause lung cancer once accumulated inside the body.

Dust classes in accordance with the EU standard

Since 1997, hazardous dust have been categorized into 3 (three) classes, namely, Class L, Class M and Class H, which is regulated by IEC69-2-60335 (world wide) and by EN 60335-2-69. The vacuum cleaners suitable for each of dust class have been also defined by these regulations as follows :

Dust class	Requirement	Permeability of limestone (marble) particles having a diameter of 5 microns or less	
H VC3211H	<ul style="list-style-type: none">• Air flow sensor• Filter protection structure *1• Structure that requires a tool for filter removal/installation *2• Structure that protects users from exposure to dust when emptying dust bag *3	less than 0.005%	1* Filters should be protected from sharp objects such as nails when they are accidentally sucked up 2* Filters loaded with dust should not be easily removed. 3* Dust should be prevented from flying around when emptying dust bags or replacing fillters
L DVC750L, DVC864L, DVC860, DVC154L DVC 150L / VC3210L VC2000L	NA	less than 1%	

HEPA *filter*

Apart from the above standard regulated by IEC/EN 60335-2-69, "HEPA" is widely recognized as one of famous guidelines of the filtration efficiency.

According to this standard, the filter of "HEPA" should remove more than 99.75% of airborne particles of 0.3µm in diameter. Thus, it stipulates only a filtration efficiency of the filter itself, while IEC/EN60335-2-69 defines the vacuum machine suitable for each dust class (construction, mechanical strength of machine) as well as its dust permeability.

In this sense, Dust Class H vacuum cleaner does not always have to be equipped with HEPA filter as long as it meets the requirements of IEC/EN60335-2-69.

Another difference between HEPA testing methods and the IEC/EN60335-2-69 is the dust loading. Filter elements for dust classes M and H are to be tested with the limestone dust particles in large quantities for checking the physical strength of filter, while HEPA tests are done with very small liquid droplets.

CORDLESS

FIXING / FASTENING

DRILLING / IMPACT DRILLING

CONCRETE DRILLING / DEMOLITION

CUTTING (CONCRETE/ MASONRY/ METAL)

MULTI TOOL

GRINDING

SANDING / POLISHING

SAWING

ROUTERING / PLANING

CLEANING

HEAT GUN / LASERS

PNEUMATIC TOOLS

GARDEN TOOLS

GENERATORS

VC3211HX1 Tool Attachments Pg. T247-254 Acc Pg. A188-195 **173** 

Vacuum Cleaner (Wet & Dry)



GYUPPA!

32 L "Dust Class H" GYUPPA Vacuum Cleaner (Wet & Dry)

- High maneuverability and easy mobility thanks to 32 Liter compact stainless steel tank
- Best suitable for working with power tools

Automatic Self-cleaning Filtration System achieved by two filter units

Constantly high suction power throughout operation because dust is removed from Prefilters every 10 seconds during operation.

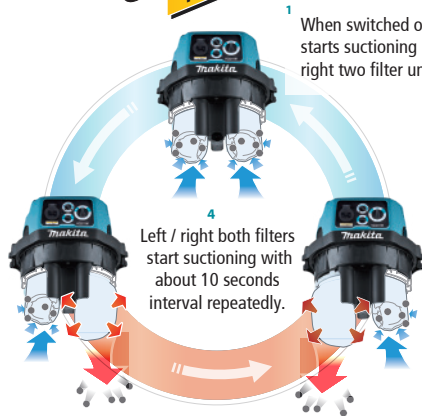

- When switched on, machine starts suctioning using left / right two filter units.
- Left filter unit starts self-cleaning by shaking off dust while right filter continues suctioning.
- Immediately after, right filter starts self-cleaning as well while left one re-starts suctioning once more.
- Left / right both filters start suctioning with about 10 seconds interval repeatedly.

Specifications:-



Continuous rating input	1,050W
Max peak air flow	2.0 m ³ / min
Max Sealed Suction (water column)	22.0 kPa
Tank capacity	Dust : 32 L Water : 27 L
Dimensions (L x W x H)	552x398x685 mm
Net weight	16.9 kg
Power supply cord	5.0 m

Standard Equipment: Hose, Front Cuffs (38, 24, 22), Belt Hook, Hose Band, Cap, Poly bag set

VC3210LX1 Tool Attachments Pg. T247-254 Acc Pg. A188-195 **173** 

Vacuum Cleaner (Wet & Dry)



GYUPPA!

32 L "Dust Class L" GYUPPA Vacuum Cleaner (Wet & Dry)

- High maneuverability and easy mobility thanks to 32 Liter compact stainless steel tank
- Best suitable for working with power tools

Automatic self-cleaning filter obtained by Triple filter structure composed of: Powder filter + Damper + Prefilter

Constantly high suction power
Easy filter cleaning simply by tapping dust off of Prefilter
Quiet cleaning because Damper and Prefilter make no noise

When the power is switched on, Prefilter collapses into itself to compress Damper, and fits closely over Damper and Powder filter.

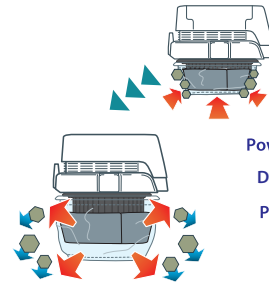

GYUPPA!
Triple Filter



When the power is switched off, Damper expands back to its original size and shakes off dust from Prefilter automatically with its expanding power.

- Allows for:
- Constantly high suction power**
 - Easy filter cleaning simply by tapping dust off of Prefilter**
 - Quiet cleaning because Damper and Prefilter make no noise**

Specifications:-



Continuous rating Input	1,050W
Max. peak air flow	2.0m ³ / min
Max. sealed suction (water column)	22.0kPa
Tank capacity	Dust : 32L Water : 27L
Overall height	552x398x685mm
Net weight	14.5kg
Power supply cord	5.0m

Standard Equipment: Hose, Front Cuffs (38, 24, 22), Holder 33-10, Bending pipe, Straight pipe, Nozzle assembly, Poly bag set

WUT02 (part # 199838-9)

Auto-Start Wireless Universal Adapter



- Enables wireless On/Off communication of Makita AWS capable tools with AC Dust Extractors that include a tool-activated power outlet
- Allows communication between battery operated tools and extractor to eliminate cords, increase productivity, and reduce noise
- Includes an adaptable hanging hook and strap for easy attachment to multiple extractors



Channel setting button is used to test the successful pairing of the tool and extractor

Caution Lamp lights up red if adapter is overheating or other malfunction occurs



Wireless unit (Bluetooth chip)
Part#: 198900-7 (optional)

Auto-start wireless system enables the Dust Extractor runs automatically



DSL800
AWS
Cordless
Dry wall
Sander

WUT02
Auto-Start
Wireless
Adapter

AC Vacuum
Cleaners
VC3210LX1
VC3211HX1



Our AWS Range

Plunge Cut
Circular saw
DKP181



Rotary Hammer
HR002G
DHR283
DHR400N
DHR182



Power Planer
DKP181



Cut-out Tool
DCO181



Circular saw
HS004G
DHS901
DHS783
DHS661



Angle Grinder
GA022G / GA023G
GA028G / GA029G



Slide
Compound
Miter Saw
DLS211
DLS111



VC2000L

Acc Pg. A188-195

Vacuum Cleaner (Wet & Dry)



20 L "Dust Class L" Vacuum Cleaner (Wet & Dry)

- Class L - Removes 99.0% of dust with limit value for occupational exposure >1.0mg/m3
- Suitable for processes involving mica, china clay, gypsum.
- Push & Clean semi-automatic filter cleaning system for extended operating time and filter life
- Convenient integrated carry handle for easier transportation
- Designed for domestic and commercial vacuum cleaning (not connection to power tools for dust extraction)
- Double Insulation



Specifications:-



Continuous rating Input	1,000W
Max. peak air flow	3.6 m ³ /min
Max. sealed suction	21.0 kPa
Tank capacity	Dust : 20L / Water : 13L
Noise sound pressure	72 dB(A)
Hose length	3.5 m
Hose Diameter	32mm
Dimensions (L x W x H)	390x385x505 mm
Net weight	7.5kg
Power supply cord	5.0m

Standard Equipment: Hose, Straight Pipes, Nozzle Assembly

CORDLESS

FIXING /
FASTENING

DRILLING /
IMPACT DRILLING

CONCRETE DRILLING /
DEMOLITION

CUTTING
[CONCRETE/ MASONRY/
METAL]

MULTI TOOL

GRINDING

SANDING / POLISHING

SAWING

ROUTERING / PLANING

CLEANING

HEAT GUN / LASERS

PNEUMATIC TOOLS

GARDEN TOOLS

GENERATORS

CORDLESS

DVC560

18V+18V LXT - Lithium-Ion Cordless Upright Vacuum Cleaner



90° range of operation for use at any angle and under furniture



Cordless Upright Vacuum to provide both a rotating power brush for deep carpet cleaning & a detachable hand-wand for cleaning with the onboard accessories.

- 3 Stage power selection for optimum suction performance
- Low profile design allows access to more areas
- Compact and lightweight

Specifications:-

Capacity	5.0L
Max. sealed suction	12.0kPa
Max. air volume	1.9m³/min
Working width	318mm
Max. airflow in Litres	30L/sec
Continuous Runtime (2 x 6.0Ah)	H: 30 / N: 60 / L: 120 mins
Overall length	1,146 mm
Net weight	9.0 kg

	5.0Ah	3.0Ah	"Z" VARIANT
DVC560 PT2 INCLUDES 2 BATTERIES / 1 TWO PORT CHARGER			DVC560 Z TOOL ONLY (WITH CARRY CASE) (DOES NOT INCLUDE BATTERY / CHARGER)



5.0L Capacity disposable bags with high-grade filtration and a HEPA filter that captures up 99.97% of particles at 0.3 micron HEPA Filter (191E39-5)

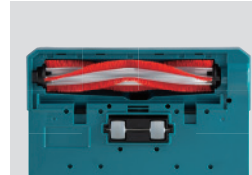

Tool Free brush removal for easy maintenance

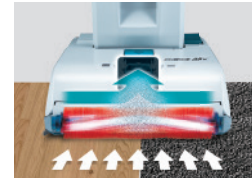

4 stage height adjustment
Features easy dial brush height adjustment, for cleaning carpet or hard floor application



Stretch hose and telescopic tube to clean sills and vents (round brush, long sash nozzle)

Onboard storage for accessories conveniently located on the back of the machine



FIXING / FASTENING

DRILLING / IMPACT DRILLING

CONCRETE DRILLING / DEMOLITION

CUTTING [CONCRETE/ MASONRY/ METAL]

MULTI TOOL

GRINDING

SANDING / POLISHING

SAWING

ROUTERING / PLANING

CLEANING

HEAT GUN / LASERS

PNEUMATIC TOOLS

GARDEN TOOLS

GENERATORS



DVC154L

Acc Pg. A188-195

18V+18V LXT - Lithium-ion Cordless Dust Extractor with AWS

(DRY)



18V + 18V → 36V
LITHIUM-ION AWS BL MOTOR XPT HEPA filter

15L

Large dust bag capacity with Hepa Filter System for powerful dust extracting solutions



Built-in wireless unit

Auto-start wireless system enables the Dust Extractor runs automatically



Efficient three stage HEPA filtration system captures 99.97% of particulates 0.3 microns and larger

HEPA filter



Higher suction power due to brushless motor

Specifications:-



Capacity	Dust: 15 L
Continuous Use (min.) (approx.)	With 2 x BL1850B: 40-100 / With 2 x BL1860B: 48-115
Max Air Flow	2.1 m³/min
Max Sealed Suction	9.8 kPa
Max Suction Power	90 W
Vibration Level	2.5 m/s² or less
Sound Pressure Level	66 dB(A)
Dimensions (L x W x H)	366x334x421 mm
Net weight	8.6 kg

Standard Equipment: Front Cuffs, 28mm Dia - 3.5m Hose, Hepa Filter Set, Polybag Set.

AVAILABLE VARIANT

"Z" VARIANT

DVC154LZ

TOOL ONLY (DOES NOT INCLUDE BATTERY / CHARGER OR CARRY CASE)

DVC864L

Acc Pg. A188-195

18V+18V LXT - Lithium-ion Cordless Dust Extractor with AWS

(DRY)



18V + 18V → 36V
LITHIUM-ION AWS BL MOTOR XPT HEPA filter

8L

Dust bag capacity with Hepa Filter System for powerful dust extracting solutions



Built-in wireless unit

Auto-start wireless system enables the Dust Extractor runs automatically



Efficient three stage HEPA filtration system captures 99.97% of particulates 0.3 microns and larger

HEPA filter

Higher suction power due to brushless motor



Specifications:-



Capacity	Dust: 8 L
Continuous Use (min.)	40 min (with BL1850B x2)
Suction Power	High: 90W
Max Air Flow	2.1 m³/min
Max Sealed Suction	9.8 kPa
Vibration Level	2.5 m/s² or less
Sound Pressure Level	70 dB(A) or less
Dimensions(L x W x H)	366x334x368 mm
Net weight	8.4 kg

Standard Equipment: Front Cuffs, 28mm Dia - 3.5m Hose, Hepa Filter Set, Polybag Set.

AVAILABLE VARIANT

"Z" VARIANT

DVC864LZ

TOOL ONLY (DOES NOT INCLUDE BATTERY / CHARGER OR CARRY CASE)

CORDLESS

FIXING / FASTENING

DRILLING / IMPACT DRILLING

CONCRETE DRILLING / DEMOLITION

CUTTING [CONCRETE/ MASONRY/ METAL]

MULTI TOOL

GRINDING

SANDING / POLISHING

SAWING

ROUTERING / PLANING

CLEANING

HEAT GUN / LASERS

PNEUMATIC TOOLS

GARDEN TOOLS

GENERATORS

- CORDLESS
- FIXING / FASTENING
- DRILLING / IMPACT DRILLING
- CONCRETE DRILLING / DEMOLITION
- CUTTING (CONCRETE/ MASONRY/ METAL)
- MULTI TOOL
- GRINDING
- SANDING / POLISHING
- SAWING
- ROUTERING / PLANING
- CLEANING
- HEAT GUN / LASERS
- PNEUMATIC TOOLS
- GARDEN TOOLS
- GENERATORS

DVC150L Tool Attachments Pg. T247-254 Acc Pg. A188-195

18V+18V LXT - Lithium-ion Cordless + Corded Vacuum Cleaner (WET & DRY)



15L Large dust bag capacity with cloth filter system enables continuous cleaning work



Versatile Use: Thanks to 2 different Power Sources Provides easy maneuverability anywhere you need cleaning



Specifications:-

Capacity	Dust / Water: 15 / 12 L
Continuous Use (min.)	With 2 x BL1850B: 30-65 / With 2 x BL1860B: 36-78
Max Air Flow	AC / DC: 3.6 / 2.1 m ³ /min
Max Sealed Suction	AC / DC: 24 / 9 kPa
Max Suction Power	AC / DC: 320 / 70 W
Vibration Level	2.5 m/s ² or less
Sound Pressure Level	AC / DC: 75 / 64 dB(A)
Dimensions (L x W x H)	366x334x421 mm
Net weight	9.6 kg

Standard Equipment: Floor Nozzle, Corner Nozzle, Bend Pipe, Straight Pipe, 38mm Dia - 2.5m Hose, Cloth Filter, Poly Bag Set

AVAILABLE VARIANT

"Z" VARIANT

DVC150LZ

TOOL ONLY (DOES NOT INCLUDE BATTERY / CHARGER OR CARRY CASE)

DVC860L Tool Attachments Pg. T247-254 Acc Pg. A188-195

18V+18V LXT - Lithium-ion Cordless + Corded Vacuum Cleaner (WET & DRY)



8L Dust bag capacity with cloth filter system enables continuous cleaning work



Versatile Use: Thanks to 2 different Power Sources Provides easy maneuverability anywhere you need cleaning



Specifications:-

Capacity	Dust: 8 / 6 L
Continuous Use (min.)	65 min. (with BL1850B x 2)
Max Air Flow	AC / DC: 3.6 / 2.1 m ³ /min
Max Sealed Suction	AC / DC: 24 / 9 kPa
Vibration Level	2.5 m/s ² or less
Sound Pressure Level	75 dB(A)
Dimensions (L x W x H)	366x334x368 mm
Net weight	8.6 kg

Standard Equipment: Floor Nozzle, Corner Nozzle, Bend Pipe, Straight Pipe, 38mm Dia - 2.5m Hose, Cloth Filter, Poly Bag Set

AVAILABLE VARIANT

"Z" VARIANT

DVC860LZ

TOOL ONLY (DOES NOT INCLUDE BATTERY / CHARGER OR CARRY CASE)

DVC665

Acc Pg. A188-195

18V+18V LXT - Lithium-ion Cordless Backpack Dust Extractor



(Dry only)



6L
Capacity

Backpack dust extractor powered by two 18V Li-ion batteries. Best suitable for working with power tools.

- 6.0L Large dust bag capacity for continuous operation
- Quiet operating achieved with noise reduction onstruction
- Featuring shoulder and waist belts adjustable to suit user's size for less fatigue even after long continuous operation
- Mode memory function allows to start in the same suction power when you turned it off previously
- Push button power selection controller (high/normal) with AWS function

Two stage HEPA filtration system

system captures 99.97% of particulates .3 microns and larger



Controller With

- Wireless unit
- 2 Stage power selection

Easily accessible side-loading batteries for added convenience

Specifications:-



Capacity	Paper dust bag: 6.0 L Cloth dust bag: 5.5 L
Continuous Use (min.)	High / Normal: 40 / 75 (with BL1860B x2)
Max Air Flow	1.8 m ³ /min (28mm-1.5m Hose)
Max Sealed Suction	11 kPa
Max Suction Power	High / Normal: 85 / 45 W (28mm-1.5m Hose)
Vibration Level	Operation w/o Load: 2.5 m/s ² or less
Sound Pressure Level	High: 66 / Normal: 62dB(A)
Dimensions (L x W x H)	297x174x523 mm
Net weight	6.7 kg

Standard Equipment: 28mm dia 1.5m hose, front cuff 22 ,38, Rubber joint 24, Paper bag

AVAILABLE VARIANTS

5.0Ah	3.0Ah	"Z" VARIANT
-	-	DVC665 Z TOOL ONLY (DOES NOT INCLUDE BATTERY / CHARGER BLUETOOTH CHIP OR CARRY CASE)

DVC265

Tool Attachments Pg. T247-254 Acc Pg. A188-195

18V+18V LXT - Lithium-ion Cordless Backpack Dust Extractor



(Dry only)

2L
Capacity

Backpack dust extractor powered by two 18V Li-ion batteries. Best suitable for working with power tools.

- Featuring shoulder and waist belts adjustable to suit user's size for less fatigue even after long continuous operation
- Mode memory function allows to start in the same suction power when you turned it off previously
- Push button power selection controller (high/normal) with AWS function

Two stage HEPA filtration system

system captures 99.97% of particulates .3 microns and larger



Controller With

- Wireless unit
- 2 Stage power selection



Specifications:-



Capacity	Paper Dust Bag: 2.0 L Cloth Dust Bag: 1.5 L
Continuous Use (min.)	High: 40 / Low: 75 (with BL1860B)
Max Air Flow	1.8 m ³ /min (28mm-1.5m Hose)
Max Sealed Suction	11 kPa
Suction Power	High / Normal: 85 / 45 W (28mm-1.5m Hose)
Vibration Level	Operation without Load: 2.5 m/s ² or less
Sound Pressure Level	High: 69 / Normal: 65dB(A)
Dimensions (L x W x H)	230x152x373 mm
Net weight	4.5 kg

Standard Equipment: 28mm dia 1.5m hose, front cuff 22 ,38, Rubber joint 24, Paper bag

AVAILABLE VARIANTS

5.0Ah	3.0Ah	"Z" VARIANT
-	-	DVC265 ZXU TOOL ONLY (WITH BLUETOOTH CHIP) (DOES NOT INCLUDE BATTERY / CHARGER OR CARRY CASE)

CORDLESS

FIXING / FASTENING

DRILLING / IMPACT DRILLING

CONCRETE DRILLING / DEMOLITION

CUTTING [CONCRETE/ MASONRY/ METAL]

MULTI TOOL

GRINDING

SANDING / POLISHING

SAWING

ROUTERING / PLANING

CLEANING

HEAT GUN / LASERS

PNEUMATIC TOOLS

GARDEN TOOLS

GENERATORS

CORDLESS
FIXING / FASTENING
DRILLING / IMPACT DRILLING
CONCRETE DRILLING / DEMOLITION
CUTTING (CONCRETE/ MASONRY/ METAL)
MULTI TOOL
GRINDING
SANDING / POLISHING
SAWING
ROUTERING / PLANING
CLEANING
HEAT GUN / LASERS
PNEUMATIC TOOLS
GARDEN TOOLS
GENERATORS

DVC660

Acc Pg. A188-195

18V+18V LXT - Lithium-ion Cordless Backpack Vacuum Cleaner



Backpack vacuum cleaner powered by two 18V Li-ion batteries.

- 6.0L Large dust bag capacity for continuous operation
- Durable 32mm - 1m hose (standard)
- Quiet operating achieved with noise reduction construction
- Featuring shoulder and waist belts adjustable to suit user's size for less fatigue even after long continuous operation
- Mode memory function allows to start in the same suction power when you turned it off previously
- Push button power selection controller (max/high/normal) with LED job light.

Two stage HEPA filtration system

system captures 99.97% of particulates .3 microns and larger

Cleaning mechanism with paper dust bag

Dust that tending to clog filters actuated automatically due to vibration or pulling down lever manually

Aluminium telescope pipe

with lock system prevents the pipe unintentionally coming off

Easily accessible side-loading batteries for added convenience



Specifications:-



Capacity	Paper dust bag: 6.0 L / Cloth dust bag: 5.5 L
Continuous Use (min.)	Max: 40 / High: 75 / Normal: 140 (with BL1860B x2)
Max Air Flow	2.2 m³/min (32mm-1m Hose)
Max Sealed Suction	11 kPa
Max Suction Power	Max / High / Normal: 95 / 50 / 25 W (32mm-1m Hose)
Vibration Level	Operation w/o Load: 2.5 m/s² or less
Sound Pressure Level	Max: 66 / High: 62 / Normal: 58 dB(A)
Dimensions (L x W x H)	297x174x523 mm
Net weight	6.7 kg

Standard Equipment: 32mm dia 1m hose, Floor Nozzle, Hose, Hose Band, Nozzle assembly, Telescopic pipe assembly, Bent Pipe, Seat nozzle, Round Brush, Flexible Nozzle, Dust Bag.

AVAILABLE VARIANTS

5.0Ah	3.0Ah	"Z" VARIANT
-	-	DVC660 ZX8 TOOL ONLY (DOES NOT INCLUDE BATTERY / CHARGER OR CARRY CASE)

DVC261

Acc Pg. A188-195

18V+18V LXT - Lithium-ion Cordless Backpack Vacuum Cleaner



Backpack vacuum cleaner powered by two 18V Li-ion batteries.

- Featuring shoulder and waist belts adjustable to suit user's size for less fatigue even after long continuous operation
- Mode memory function allows to start in the same suction power when you turned it off previously
- Delivers up to 140 min of run time using BL1860B on normal setting
- Push button power selection controller (max/high/normal) with LED job light

Two stage HEPA filtration system

system captures 99.97% of particulates .3 microns and larger



Aluminium telescope pipe pipE with lock system prevents the pipe unintentionally coming off

Specifications:-



Capacity	Paper Dust Bag: 2.0 L / Cloth Dust Bag: 1.5 L
Continuous Use (min.)	Max: 40 / High: 75 / Normal: 140 (with BL1860Bx 2)
Max Air Flow	2.0 m³/min (28mm-1m Hose)
Max Sealed Suction	11 kPa
Suction Power	Max / High / Normal : 90 / 45 / 25 W (28mm-1m Hose)
Vibration Level	Operation w/o Load: 2.5 m/s² or less
Sound Pressure Level	Max: 69 / High: 65 / Normal: 62 dB(A)
Dimensions (L x W x H)	230x152x373 mm
Net weight	4.5 kg

Standard Equipment: 28mm dia 1m hose, Floor Nozzle, Hose, Hose Band, Nozzle assembly, Telescopic pipe assembly, Bent Pipe, Flexible Nozzle, Dust Bag

AVAILABLE VARIANTS

5.0Ah	3.0Ah	"Z" VARIANT
-	-	DVC261 ZX11 TOOL ONLY (DOES NOT INCLUDE BATTERY / CHARGER OR CARRY CASE)

DRC200

LXT Cordless Robotic Cleaner



Robotic cleaner for commercial/industrial use

- Able to clean an area of 300m² per 120min, with a coverage rate of 80% (two BL1830B in parallel)
- Wireless remote controller

Automatic cleaning (Selectable two dust collection modes)

Pattern cleaning mode

Random cleaning mode



Cleaning area setting function



Enables user to define a cleaning area by putting boundary tape on the floor as boundary line that the cleaner cannot pass

Large side brushes + Large power brush

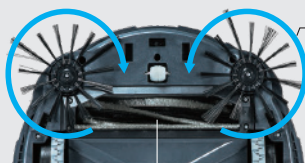

Side brushes enable to clean alongside walls, around obstacles or tight corners in either of pattern/random

ø50mm x 260mm Large Power rotating brush

Power Brush Part no: SH0000063
Turn Brush Cover Part no: SH0000064



Side Brush Part no: SH0000065

Dust box with 2.5L capacity

Dual compartment structure - one for small debris, the other for large debris and Equipped with a highly efficient filter Part no: SH00000213



Excellent cleaning features useful in commercial applications

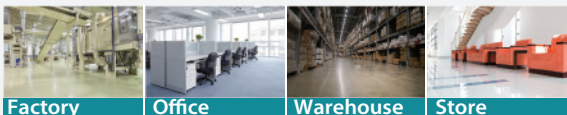

Specifications:-

Continuous use (minutes)	120-200
Max cleaning area	with BL1830Bx2: 300 m ² with BL1850Bx2: 500 m ²
Max running speed	0.3 m/sec
Tank	2.5L
Dimensions (L x W x H)	460x460x180mm
Net weight	7.3kg

Standard Equipment: Wireless remote controller (including two AAA alkaline batteries), Side brush, Boundary tape (15m roll)

AVAILABLE VARIANTS

5.0Ah	3.0Ah	"Z" VARIANT
-	-	DRC200 Z TOOL ONLY (DOES NOT INCLUDE BATTERY / CHARGER OR CARRY CASE)

DVC750L

Acc Pg. A188-195

18V LXT - Lithium-ion Cordless Vacuum Cleaner / Dust Extractor / Blower

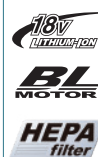

Compact, portable and easy-to-use

3 in ONE tools (Cleaning / Dust Extraction / Blowing)

High power and long run time with Brushless Motor

Nozzle can be stored



Blower outlet Insert the hose to blower outlet and turn it clockwise until it clicks.



Hose can be stored

For vacuum cleaning
Elastic Hose: 28mm - 2m
with from cuff 38



Specifications:-



Capacity	Dust : 7.5 L / Water : 4.5L
Continuous Use (min.)	w/ BL1860B (High) : 35 / w/ BL1860B (Low) : 70
Max Air Flow	1.6 m ³ /min
Max Sealed Suction	6.7 kPa
Suction Power	High / Low : 50 / 25 W
Dimensions (L x W x H)	418x251x278 mm
Net weight	4.6 kg

Standard Equipment: Hose, Floor Nozzle, Sash Nozzle

AVAILABLE VARIANTS

5.0Ah	3.0Ah	"Z" VARIANT
-	-	DVC750L ZX1 TOOL ONLY (DOES NOT INCLUDE BATTERY / CHARGER OR CARRY CASE)

CORDLESS

FIXING / FASTENING

DRILLING / IMPACT DRILLING

CONCRETE DRILLING / DEMOLITION

CUTTING [CONCRETE/ MASONRY/ METAL]

MULTI TOOL

GRINDING

SANDING / POLISHING

SAWING

ROUTERING / PLANING

CLEANING

HEAT GUN / LASERS

PNEUMATIC TOOLS

GARDEN TOOLS

GENERATORS

CORDESS
FIXING / FASTENING
DRILLING / IMPACT DRILLING
CONCRETE DRILLING / DEMOLITION
CUTTING (CONCRETE/ MASONRY/ METAL)
MULTI TOOL
GRINDING
SANDING / POLISHING
SAWING
ROUTERING / PLANING
CLEANING
HEAT GUN / LASERS
PNEUMATIC TOOLS
GARDEN TOOLS
GENERATORS

DVC350 Acc Pg. A188-195

18V LXT - Lithium-ion Cordless Dust Extractor / Blower



Portable Dust extractor powered by 18V Li-ion battery.

- Variable switch provides High/Low air volume settings to suit your application.
- Shoulder belt can be easily slung over your shoulder for added mobility.

2 functions in 1 machine
Convertible into a blower by attaching nozzle assembly.



Nozzle assembly

Length	Part No.
220mm	132025-7
430mm	134182-7

Anchor nozzle Part no: 192236-6
used with nozzle assembly for blower option

Convenient for use with Makita cordless tools



Concrete Drilling
(with Combination Hammer)



Concrete Cutting
(with Angle Grinder)



Wood Cutting
(with Jig Saw)



Wood Cutting
(with Circular Saw)

Specifications:-



Max. peak air flow	3.4m ³ / min
Max. sealed suction (water column)	5.5kpa
Recoverable capacity	3.0L
Dimensions (L x W x H)	273 x 195 x 226mm
Net weight	2.2kg

Standard Equipment: Nozzle Assembly, Dust Bag Assembly, Hose Complete with front cuffs, Shoulder Belt

AVAILABLE VARIANTS

5.0Ah	3.0Ah	"Z" VARIANT
-	-	DVC350 Z TOOL ONLY (DOES NOT INCLUDE BATTERY / CHARGER OR CARRY CASE)

DCL501 Acc Pg. A189-191

LXT Cordless Cyclone Cleaner

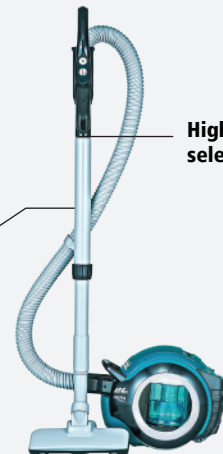

High / Low Power selection

Telescopic pipe

Can be extended to allow for grip height adjustment to suit users height.

Warning lights



1. Orange LED indicator for filter cleaning warning
2. Red LED indicator for battery capacity warning

HEPA filter with high filtration capacity.

Advanced Filtration system with cyclone separation

Cleaner has the advanced Cyclonic filtration system with HEPA filter collects large and small dust particles efficiently



Easy dust disposal



- Dust cup can be removed for easy dust disposal simply by pulling up the cup release lever then by pushing the release button
- The dust cup and the filter are washable in water

Specifications:-



Capacity	250 mL
Continuous Use (min.)	High: 35 / Low: 77 (with BL1860B)
Max Air Flow	1.2 m ³ /min
Max Sealed Suction	10 kPa
Dimensions (L x W x H)	352x189x252 mm
Net weight	3.1 kg

Standard Equipment: Shoulder Belt, Crevice Nozzle, Cleaning Brush, Floor Nozzle, Telescopic Pipe, Hose, Hose Hook

AVAILABLE VARIANTS

5.0Ah	3.0Ah	"Z" VARIANT
-	-	DCL501 Z TOOL ONLY (DOES NOT INCLUDE BATTERY / CHARGER OR CARRY CASE)



DCL281 Acc Pg. A188-192

18V LXT - Lithium-ion Cordless Cleaner



**Quiet cleaning & Low vibration
Ideal for Commercial and Home Use**

Achieved by noise absorbing sponge attached inside housing.
Low vibration achieved by using softer elastomer on fan cover.

- Brushless Motor Provides: High Power | High Performance | High Durability
- Connect various types of nozzles to clean commercial spaces like shops, offices, hospitals, aircrafts, trains, home use, etc.
- Free From cord: 18V Li-ion Battery: World's largest compatible lithium-ion system

Push button with 3-speed power selection (high/medium/low) for efficient operation



LED joblight

Durability



Pipe is fixed with the locking mechanism to prevent it from accidentally coming off.

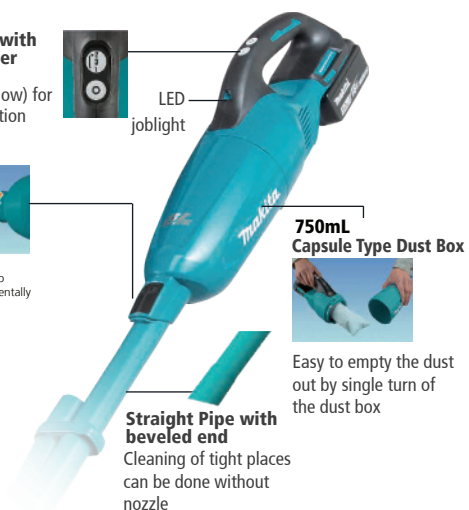

750mL Capsule Type Dust Box



Easy to empty the dust out by single turn of the dust box

Straight Pipe with beveled end
Cleaning of tight places can be done without nozzle

Hepa filter is used with either Pre-filter or Easy shake off filter

HEPA Filter
High Durability Filter System Designed for capturing extra fine dust



Hepa-filter: Part No.199989-8 (Standard equipment)



Pre-filter: Part No. 198750-0 (Standard equipment)



Easy shake off filter: Part No.199966-0 (Optional)

Specifications:-

Capacity	750 mL
Continuous Use (min.)	Max: 15 High: 20 Low: 50 (with BL1830B) Max: 25 High: 33 Normal: 83 (with BL1850B) Max: 30 High: 40 Normal: 100 (with BL1860B)
Max Air Flow	1.5 m³/min
Max Sealed Suction	8.2 kPa (820 mm H2O)
Suction Power	Max / High / Low : 60 / 45 / 15 W
Dimensions (L x W x H)	1,016x113x154 mm
Net weight	1.6 kg

Standard Equipment: Floor Nozzle, Sash Nozzle, Sash Nozzle Holder, Straight Pipe, Prefilter, HEPA Filter

AVAILABLE VARIANTS

5.0Ah	3.0Ah	"Z" VARIANT
-	-	DCL281 Z TOOL ONLY

DCL180 Acc Pg. A188-192

18V LXT - Lithium-ion Cordless Cleaner



**Optimum cordless cleaner for constructors or industrial users
Dust disposal can be cleaner and simpler with disposable paper dust bag.**

- Touch button switch with High/Low suction power settings.
- LED battery power warning lamp.
- Improved front cover design for easy dust bag removal.

Ergonomic handle with easy on/off trigger switch

650 mL
Large dust capacity

Sash Nozzle



Capsule Type
Quick dust disposal
No need to use paper bag



Floor T-nozzle with enhanced maneuverability

Angled suction port
Prevents extension pipe from wobbling in use



Specifications:-

Capacity	650 mL
Continuous Use (min.)	20 min (with BL1830B)
Max Air Flow	1.4 m³/min
Max Sealed Suction	4.2 kPa
Dimensions (L x W x H)	999x114x152 mm
Net weight	1.2 kg

Standard Equipment: Floor T-Nozzle28, Sash Nozzle, Sash Nozzle Holder, Pipe, Filter, Prefilter

AVAILABLE VARIANTS

5.0Ah	3.0Ah	"Z" VARIANT
-	DCL180 RF INCLUDES 1 BATTERY / 1 CHARGER	DCL180 Z TOOL ONLY

CORDLESS

FIXING / FASTENING

DRILLING / IMPACT DRILLING

CONCRETE DRILLING / DEMOLITION

CUTTING [CONCRETE/ MASONRY/ METAL]

MULTI TOOL

GRINDING

SANDING / POLISHING

SAWING

ROUTERING / PLANING

CLEANING

HEAT GUN / LASERS

PNEUMATIC TOOLS

GARDEN TOOLS

GENERATORS

- CORDLESS
- FIXING / FASTENING
- DRILLING / IMPACT DRILLING
- CONCRETE DRILLING / DEMOLITION
- CUTTING [CONCRETE/ MASONRY/ METAL]
- MULTI TOOL
- GRINDING
- SANDING / POLISHING
- SAWING
- ROUTERING / PLANING
- CLEANING
- HEAT GUN / LASERS
- PNEUMATIC TOOLS
- GARDEN TOOLS
- GENERATORS

CL108FD

Acc Pg. A188-192

12V MAX CXT Lithium-ion Cordless Cleaner



Quiet cleaning operation, Lightweight and High Power ideal for Commercial & Residential areas

one touch on / off switch

with 3 speed selection



LED joblight

With battery exhaust notification function (Flashes when the battery capacity becomes low) Convenient for cleaning in dark areas.

600 mL

Large dust capacity

Capsule Type

Quick dust disposal
No need to use paper bag



Angled suction port

Prevents extension pipe from wobbling in use

Continuous use

21min with BL1020B(2.0h)
42min with BL1040B (4.0Ah)

Specifications:-



Capacity	600 mL
Continuous Use (min.)	With BL1041B: Max/ High/ Normal: 20/ 24/ 50
Max Air Flow	1.3 m³/min
Max Sealed Suction (water column)	4.4 kPa
Suction Power	Max/ High/ Normal: 32/ 20/ 5W
Dimensions (L x W x H)	956x110x150 mm
Net weight	1.2 kg

Standard Equipment: Floor T-Nozzle28, Sash Nozzle, Sash Nozzle Holder, Pipe, Filter, Prefilter

AVAILABLE VARIANTS

4.0Ah (BLUE)	4.0Ah (WHITE)	2.0Ah	"Z" VARIANT (BLUE)	"Z" VARIANT (WHITE)
CL108FD SM INCLUDES 1 BATTERY / 1 FAST CHARGER	CL108FD SMW INCLUDES 1 BATTERY / 1 FAST CHARGER	-	CL108FD Z TOOL ONLY (DOES NOT INCLUDE BATTERY / CHARGER)	CL108FD ZW TOOL ONLY (DOES NOT INCLUDE BATTERY / CHARGER)

CL106FD

Acc Pg. A188-192

12V MAX CXT Lithium-ion Cordless Cleaner



Quiet cleaning operation in Commercial & Residential areas

on/off trigger switch

located in the convenient position and can turn on quickly only when you want to use the machine



LED joblight

With battery exhaust notification function (Flashes when the battery capacity becomes low) Convenient for cleaning in dark areas.

600 mL

Large dust capacity

Capsule Type

Quick dust disposal
No need to use paper bag



Angled suction port

Prevents extension pipe from wobbling in use

Continuous use

21min with BL1020B(2.0h)
42min with BL1040B (4.0Ah)

Specifications:-



Capacity	600 mL
Continuous Use (min.)	With BL1041B: 42
Max Air Flow	1.3 m³/min
Max Sealed Suction (water column)	3.1 kPa
Suction Power	19 W
Dimensions (L x W x H)	958x100x150mm
Net weight	1.1 kg

Standard Equipment: Floor T-Nozzle28, Sash Nozzle, Sash Nozzle Holder, Pipe, Filter, Prefilter

AVAILABLE VARIANTS

4.0Ah	2.0Ah	"Z" VARIANT
CL106FD WM INCLUDES 1 BATTERY / 1 CHARGER	-	CL106FD Z TOOL ONLY (DOES NOT INCLUDE BATTERY / CHARGER)

DCL184

Acc Pg. A189-192

18V Li-ion LXT Lithium-ion Cordless Cleaner / Blower



Compact cordless cleaner Powered by 18V Li-ion LXT battery

- Ideal for in-car cleaning
- Variable attachments suitable for in-car cleaning
- 2 functions in 1 machine convertible into a blower
- Up to 67 min. of continuous use from a single fully charged BL1041B
- Battery capacity warning lamp starts blinking when the remaining battery capacity gets low

Specifications:-



Capacity	Cloth / Paper Dust Bag: 500 / 330 mL
Continuous Use(min.)	Max / High / Normal: 33 / 50 / 133
Max Air Flow/	Cleaning: 1.4 m³/mi / Blowing: 0.8 m³/min
Max Air Velocity	Blowing: 7.2 m/s
Max Sealed Suction (water column)	5.4 kPa
Noise Level	Max / High / Normal: 68 / 65 / 58 dB(A)
Dimensions (L x W x H)	365x138x202 mm
Net weight	2.2 kg

Standard Equipment: Seat vacuum nozzle, Mat nozzle, Rubber nozzle, Soft brush, Blower attachment, Dust Bag, Shoulder Belt

AVAILABLE VARIANTS

5.0Ah	3.0Ah	"Z" VARIANT
-	DCL184 RF INCLUDES 1 BATTERY / 1 CHARGER AND TOOL BAG	DCL184 Z TOOL ONLY (DOES NOT INCLUDE BATTERY / CHARGER AND'S TOOL BAG)

CL121D

Acc Pg. A189-192

12V MAX CXT Lithium-ion Cordless Cleaner / Blower



Compact cordless cleaner Powered by Slide Li-ion Battery of Makita's 12Vmax Platform

- Ideal for in-car cleaning
- Variable attachments suitable for in-car cleaning
- 2 functions in 1 machine convertible into a blower
- Up to 67 min. of continuous use from a single fully charged BL1041B
- Battery capacity warning lamp starts blinking when the remaining battery capacity gets low

Specifications:-



Capacity	Dust Bag : 500 mL / Paper Pack : 330 mL
Continuous Use (w/ BL1041B) (min.)	Max : 27 / High : 32 / Normal : 67
Max Air Flow	1.3 m³/min
Max Sealed Suction (water column)	4.4 kPa (450 mmH ₂ O)
Suction Power	Max : 30 W / High : 20 W / Normal : 5 W
Dimensions (L x W x H)	345x138x202 mm
Net weight	1.8 kg

Standard Equipment: Seat vacuum nozzle, Mat nozzle, Rubber nozzle, Soft brush, Blower attachment, Dust Bag, Shoulder Belt

AVAILABLE VARIANTS

4.0Ah	2.0Ah	"Z" VARIANT
CL121D SM INCLUDES 1 BATTERY / 1 CHARGER AND TOOL BAG	-	CL121D Z TOOL ONLY (DOES NOT INCLUDE BATTERY / CHARGER AND'S TOOL BAG)

Ideal for in-car cleaning



Especially designed variable attachments



Rubber nozzle 330
422437-5



Seat nozzle 120 complete
140H95-0



Mat nozzle 120
459056-4



Blower nozzle complete
140J64-3



Soft brush 360 complete
140H94-2



Tool Bag (only with CL121DSM / DCL184RF)

Paper filter set (5pcs/set) (Optional)
Part No. 194566-1



CORDLESS

FIXING / FASTENING

DRILLING / IMPACT DRILLING

CONCRETE DRILLING / DEMOLITION

CUTTING [CONCRETE/ MASONRY/ METAL]

MULTI TOOL

GRINDING

SANDING / POLISHING

SAWING

ROUTERING / PLANING

CLEANING

HEAT GUN / LASERS

PNEUMATIC TOOLS

GARDEN TOOLS

GENERATORS

CORDESS
FIXING / FASTENING
DRILLING / IMPACT DRILLING
CONCRETE DRILLING / DEMOLITION
CUTTING (CONCRETE/ MASONRY/ METAL)
MULTI TOOL
GRINDING
SANDING / POLISHING
SAWING
ROUTERING / PLANING
CLEANING
HEAT GUN / LASERS
PNEUMATIC TOOLS
GARDEN TOOLS
GENERATORS

CL183D
Acc Pg. A188-192

18V G-Series Lithium-ion Cordless Cleaner

18V

Low noise design ideal for quiet cleaning operation in job sites

- Compact and lightweight design.
- Bagless 2-stage cloth filtration system allows for easier cleaning
- Filter and pre-filter are washable in soapy water for repeated use
- Sash nozzle for cleaning corners and crevices of a car or furniture
- Angled suction port allows for easy floor cleaning without floor nozzle
- Ideal for shop, office, hospital, airport, plane, station, train, home use, etc

Specifications:-

Capacity	600 mL
Continuous Use (min.)	24
Max Air Flow	1.3 m³/min
Max Sealed Suction	2.6 kPa
(water column)	966x102x148 mm
Dimensions (L x W x H)	1.1 kg

Standard Equipment: Floor T-Nozzle28, Sash Nozzle, Sash Nozzle Holder, Pipe, Filter, Prefilter

AVAILABLE VARIANTS

1.5Ah	"Z" VARIANT
CL183D W (IVORY COLOUR) INCLUDES 1 BATTERY / 1 CHARGER	CL183D Z (IVORY COLOUR) TOOL ONLY (DOES NOT INCLUDE BATTERY / CHARGER)

DLX2248PT1

LXT Cordless Cleaner Combo Kit

DVC260Z
18+18V Li-ion Backpack
Vacuum Cleaner

DCL181FZ
18V Li-ion Cleaner

2 Port
Charger
DC18RD

3Pcs x 18V Li-ion
5.0Ah Battery
BL1850B

Rubber
Nozzle

Flexible
Hose

Corner
Nozzle

Seat
nozzle

Round
Brush

10pcs
Paper Filter
for DCL181

10pcs
Cloth Filter
for DVC260

Specifications:-

	DCL181	DVC260
Capacity	650 mL	2.0L
Continuous Use (min.)	High: 20 / Low: 40 (with BL1830B)	High: 60 / Low: 90 (with BL1850Bx2)
Max Air Flow	1.4 m³/min	1.5m³ / min
Max Sealed Suction	5.3kPa	7.1kPa
Dimensions (L x W x H)	999x114x152 mm	230x152x373mm
Net weight	1.2 kg	4.3kg

Product Comparison List

	Model No.	Dust class	Powered	Tank capacity Dust & Water (L)	Tank type	Max Air Flow (m³ / min)	Max Sealed Suction (kpa)	Switch of connected power tool
SAWING	DVC864L	L (HEPA filter)	DC (LXT18Vx2)	8 / 15 (Dust only)	Plastic	2.1**	9.8	AWS
	DVC860L / 154L	L	AC/DC (LXT18Vx2)	8 & 6 / 15 & 12	Plastic	AC/DC : 3.6 / 2.1**	AC/DC : 24 / 9.0	-
	DVC260	(HEPA filter)	DC (LXT18Vx2)	Filter bag 2.0/ Dust bag 1.5 (Dust only)	Dust bag or Filter bag	1.5*	11	-
ROUTERING / PLANING	DVC265	(HEPA filter)	DC (LXT18Vx2)	Filter bag 2.0/ Dust bag 1.5 (Dust only)	Dust bag or Filter bag	2.0*	11	AWS
	DVC350	-	DC (LXT18Vx1)	3/- (Dust only)	Dust bag	1.4*	6	-
CLEANING	VC3211H	H	AC	32/27	Stainless steel	2.0* / 3.5**	22	Automatic
	VC3210L	L	AC	32/27	Stainless steel	2.0* / 3.5**	22	-
	VC2000L	L	AC	20/- (Dust only)	Plastic		21	-
HEAT GUN / LASERS	DVC360L	(HEPA filter)	DC (LXT18Vx2)	5L	Plastic	1.9	12	-
	DCL501	(HEPA filter) With Cyclonic Filtration	DC (LXT18Vx1)	250mL	Dust cup	1.2	10	-
	DVC750L	L (HEPA filter)	DC (LXT18Vx1)	7.5/4.5	Plastic	1.6	6.7	-
PNEUMATIC TOOLS	DCL281	(HEPA filter)	DC (LXT18Vx1)	750mL	Capsule type	1.5	8.2	-
	DCL180	-	DC (LXT18Vx1)	650mL	Capsule type	1.4	4.2	-
	DCL184	-	DC (LXT18Vx1)	500mL	Plastic	1.4	5.4	-
GARDEN TOOLS	CL121D	-	DC (CXT12V max)	500mL	Plastic	1.3	4.4	-
	CL108FD	-	DC (CXT12V max)	600mL	Capsule type	1.2	4.4	-
	CL106FD	-	DC (CXT12V max)	600mL	Capsule type	1.3	3.1	-
GENERATORS	CL183D	-	DC (G-series18V)	600mL	Capsule type	1.3	2.6	-

*with hose 28-1m **with hose 38-25



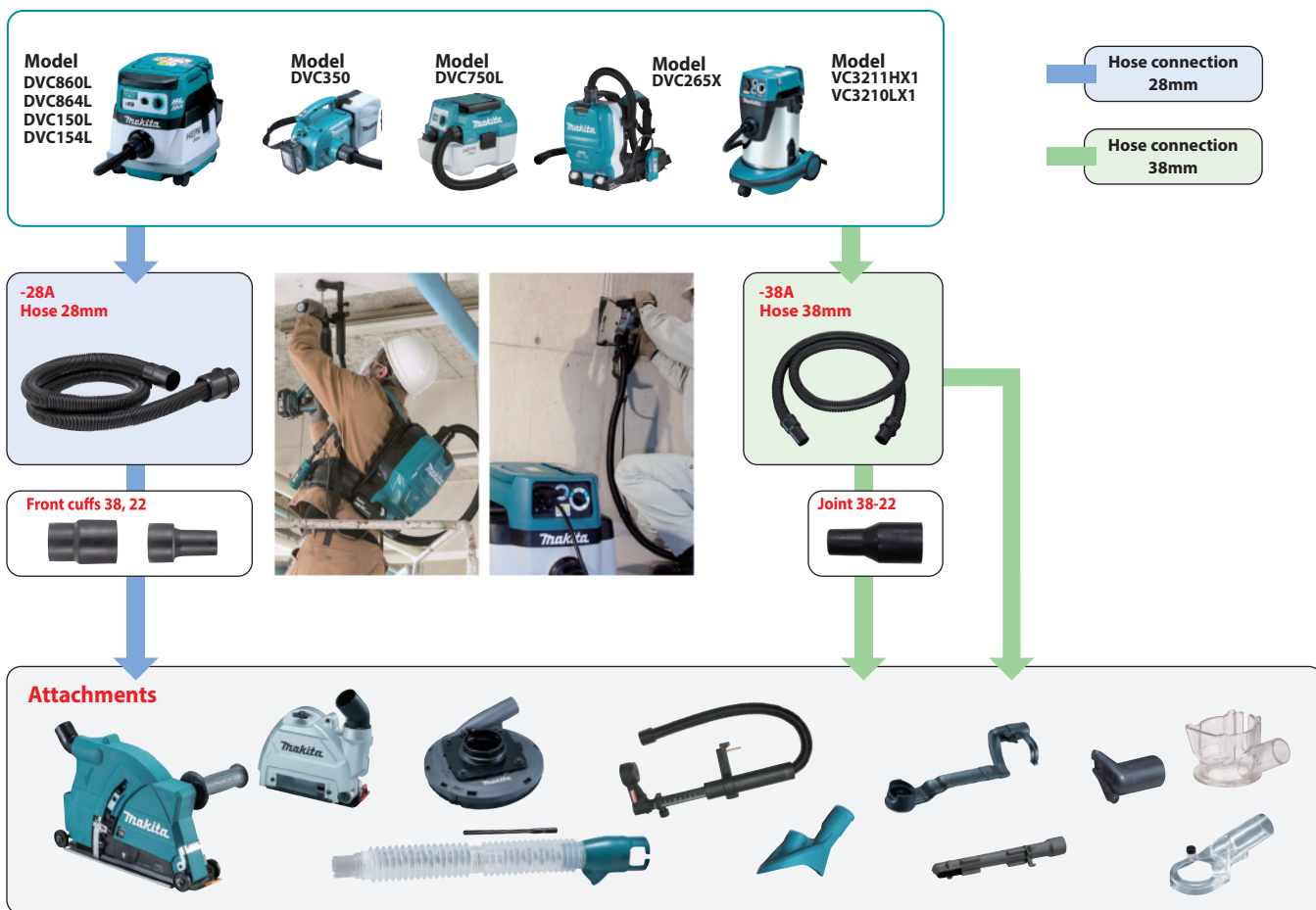



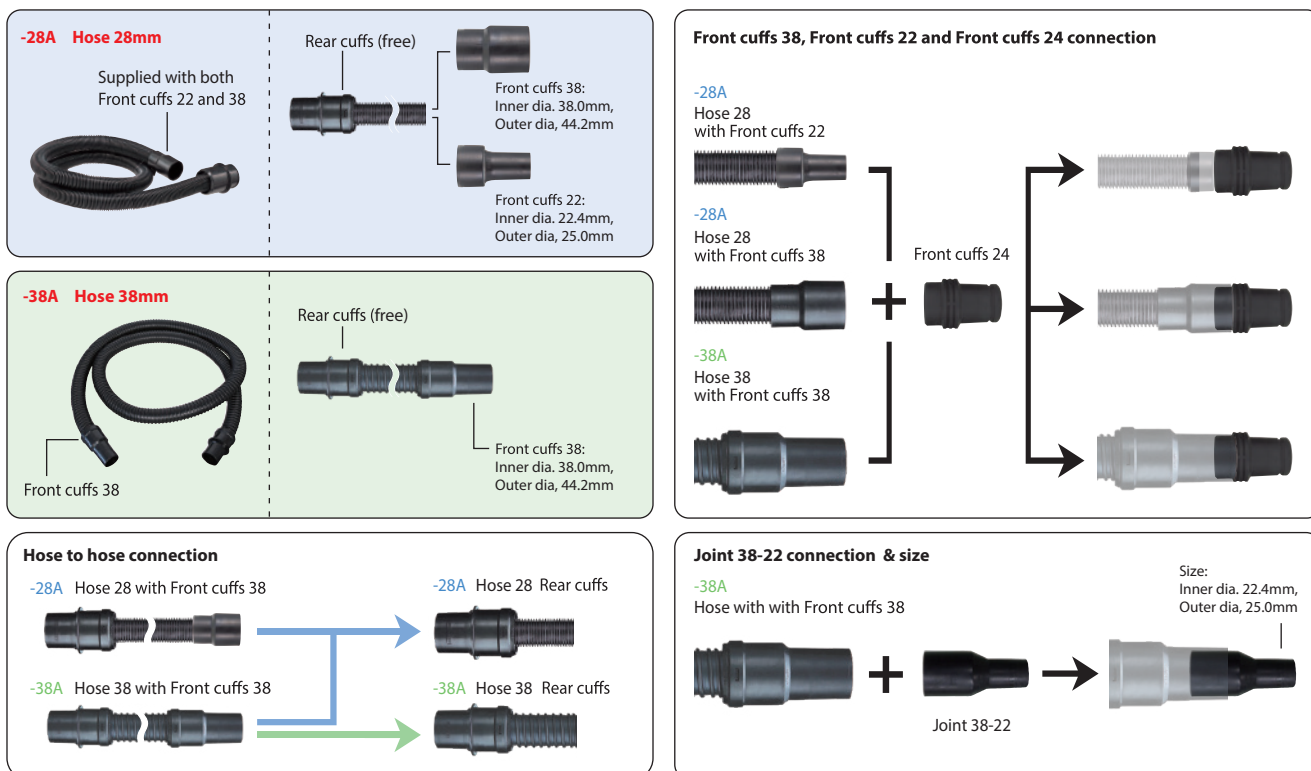

Flow Chart - Dust Collecting with Power Tools





Front cuffs, Joint & Hose Connection









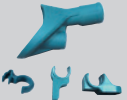

System Chart - Dust Collecting with Power Tools

A: VC3210LX1 VC3211HX1	B: DVC864L DVC154L	C: DVC860L / DVC750	D: DVC265 DVC665	E: DVC350	FRONT CUFFS	JOINT
					<div style="display: flex; justify-content: space-around;"> <div style="text-align: center;"> 38 Dia 38mm  Thread type: Fit with 28mm Hose Part No 195545-2 </div> <div style="text-align: center;"> 22 Dia 22mm  Thread type: Fit with 28mm Hose Part No 195547-8 </div> <div style="text-align: center;"> 24 Dia 24mm  Rubber Type can fix with 38 & 22mm cuffs Part No 195546-0 </div> <div style="text-align: center;"> 22-38 Dia 22mm  Fit with front cuff 38 Part No 195548-6 </div> </div>	
Standard equipments 38mm dia hose with fixed cuff 38. 28mm dia hose with attachable front cuff 22 and 38. Rubber front cuff 24	Standard equipments: 28mm dia hose with front cuffs 38, 22 & 24	Standard equipments: 38mm dia hose with fixed cuff 38	Standard equipments: 28mm dia hose with attachable front cuff 22 and 38. Rubber front cuff 24.	Standard equipments: 28mm dia hose with attachable front cuff 22 and 38. Rubber front cuff 24.		





















Hose Type a: Removable: front cuff can be removed and interchangeable with 22 and 38 front cuffs
 Type b: Front cuff is fixed with hose and cannot be removed

Type a Cuffs can be detachable 
Type b fixed cuff 

Hose length (m)	Hose Dia	With Front Cuffs	Type	Recommended for Vacuum Cleaners	Part No	Standard Equipments for Vacuum Cleaners
1.5m	28mm	38	a	DVC265X / DVC665 / DVC350	152992-0	
1.5m	28mm	22, 38	a	VC3211HX1, VC3210LX1, DVC860L, DVC864L, DVC150L, DVC154L, DVC265X, DVC665X, DVC350	A-34235	DVC265X / DVC665 / DVC350
2.5m	38mm	38	b	VC3211HX1, VC3210LX1, DVC860L	195434-1	VC3211HX1, VC3210LX1, DVC860L / 150L
2.5m	28mm	22, 24, 38	a	VC3211HX1, VC3210LX1, DVC860L, DVC864L, DVC150L, DVC154L, DVC265X, DVC665X, DVC350	195437-5	
3.5m	28mm	22, 24, 38	a	VC3211HX1, VC3210LX1, DVC860L, DVC864L, DVC150L, DVC154L, DVC265X, DVC665X, DVC350	195433-3	VC3211HX1, VC3210LX1, DVC864L / 154L
5m	28mm	22, 24, 28	a	VC3211HX1, VC3210LX1, DVC860L, DVC864L, DVC150L, DVC154L, DVC265X, DVC665X, DVC350	195436-7	
5m	38mm	38	b	VC3211HX1, VC3210LX1, DVC860L, DVC864L, DVC150L, DVC154L,	195435-9	
2m	38mm	38	b	DVC750L	140G04-3	DVC750L

POWER TOOLS	SUCTION DEVICE	EXTRACTION UNITS WITH HOSE & CUFFS
Rotary / Demolition Hammer (with Hammering mode only) SDS-Max Hammers: DHR400N, HR3540C/41FC, HR4030C, HR4001C/02//11C, HR4501C//11C, HM0870C/71C, HM1101C/11C, HM1203C/13C, HM1214C, • Bull points with over 280mm Length • Cold chisels with over 280mm Length • Scaling chisels (for tile) • Bushing tool • Scaling chisels length 17mm Hex Hammers: HR3540C, HR4030C • Bull points with over 280mm Length • Cold chisels with over 280mm Length	Dust extractor attachment set 196568-3 (w/o hose)  Dust extractor attachment set 199143-4 (w/o hose)	A VC3210LX1 / VC3211HX1  B DVC864L / 154L  C DVC860L / 150L  D DVC265 / DVC665  E DVC350  F DVC750L 
Electric Breaker HM1304, HM1306, HM1317C, HM1307C, HM1810, HM1801, HM1812, HM1802	Vacuum attachment set 197168-2 (w/o hose) 197148-8 (w/ hose) 	

ø28mm hose can be directly connected to the suction device without front cuff

POWER TOOLS		SUCTION DEVICE		EXTRACTION UNITS WITH HOSE & CUFFS		
Rotary / Combi Hammer HR1841F, DHR182, DHR171, HR166D DHR202, DHR263 HR2800, HR2810 HR002G, DHR281, DHR283, HR2610T, HR2611FT, HR2630T, HR2631FT HR003G, DHR242, DHR280, HR2600, HR2630, HR2631F, HR2661 		Grip base set + Dust cup set 194581-5 + 198362-9 194582-3 + 198362-9 - 198362-9 - 195179-1 - 195173-3 		 <p>Dust cap set Hose with front cuff can attached here</p>		<p>A VC3210LX1 / VC3211HX1  22</p> <p>B DVC864L / 154L  22</p> <p>C DVC860L / 150L 38 + 22-38  22</p> <p>D DVC265 / DVC665  22</p> <p>E DVC350  22</p> <p>F DVC750L 38 + 22-38 </p>
Rotary / Combi Hammer HR166D, DHR171, DHR182, DHR263, DHR264, HR2020, HR2460/F, HR2470/F/FT/T, HR26 & HR28 series 		Dust Extractor 193472-7  <p>Dust Extractor</p>				
Rotary Hammer HR2010 		Dust Extractor 192176-8  <p>Hose with front cuff</p>				
Rotary Hammer (Max. Bit Diameter 40mm) HR4011C, HR4001C HR4511C/01C, HR4002 DHR400N, HR4013C, HR4003C HR5212C, HR5202C 		Vacuum attachment 196074-8 199142-6 196858-4  <p>Hose with front cuff</p>				
Angle Grinder N9500N, 9500NB 		Dust collecting wheel guard 192212-0 + Rubber sleeve 192202-3 		 <p>Rubber sleeve Hose with front cuff Wheel guard</p>		
Angle Grinder For 115, 125mm For 100mm 		Dust collecting wheel guard 192618-2 192475-8 				

38 Front cuff 38 (used with 28mm dia hose)

























22 Front cuff 22 (used with 28mm dia hose)

38 Fixed front cuff 38 (comes with 38mm dia Hose)

22-38 Joint

38 Fixed front cuff 38 (Flexible hose for DVC750L)

24 Rubber front cuff 24

POWER TOOLS	SUCTION DEVICE	EXTRACTION UNITS WITH HOSE & CUFFS
Angle Grinder For 115, 125mm models for the grinder with 1 notch on bearing box For XGT grinders	Dust collecting wheel guard For cup type diamond wheel 195237-3 191F81-2	 Wheel guard Hose with front cuff
Angle Grinder For 115, 125mm models for the grinder with 3 notches on bearing box for the grinder with 1 notch on bearing box For X-LOCK grinders For XGT grinders	Dust collecting wheel guard 196846-1 196845-3 191G05-4 191G06-2	 Hose with front cuff Wheel guard
Angle Grinder 	Dust collecting wheel guard  For 115, 125mm 193794-5 For 180mm 194303-3 For 230mm 194044-1	 Hose with front cuff Wheel guard
Angle Grinder For 230mm models 	Dust collecting wheel guard  198380-7	
Angle Cutter 4112HS 	Elbow joint 32 192613-2 	 Hose with front cuff Elbow joint
Dustless Cutter 4105KB 		
Wall Chaser SG1251, SG1250 	Directly connected	 Extraction point (comes along with the machine) Hose with front cuff
Concrete Planer PC5000C, PC5001C 	Directly connected	 Hose with front cuff
Belt Sander 9924DB 	Joint 192518-6 	
Belt Sander 9403, 9404, 9910, 9920, 9921 	Directly connected	 Hose with front cuff Extraction point (comes along with the machine)
Wheel Sander 9741 	Joint 410899-9 	

A VC3210LX1 / VC3211HX1



B DVC864L, DVC154L



C DVC860L, DVC150L



D DVC265, DVC665



E DVC350



F DVC750L



38 Front cuff 38 (used with 28mm dia hose)













22 Front cuff 22 (used with 28mm dia hose)















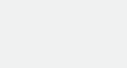







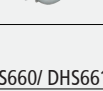

38 Fixed front cuff 38 (comes with 38mm dia Hose)

22-38 Joint

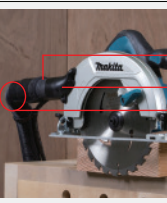
38 Fixed front cuff 38 (Flexible hose for DVC750L)

24 Rubber front cuff 24

POWER TOOLS	SUCTION DEVICE		EXTRACTION UNITS WITH HOSE & CUFFS
Belt Sander 9032 	Dust nozzle 122652-8 	 <p>Dust nozzle</p> <p>Hose with front cuff</p>	A VC3210LX1 / VC3211HX1 
Belt Sander 9031 	Directly connected		B DVC864L / 154L 
Finishing Sander 9046, BO3700, BO3710 BO4900, BO4901, BO4555 BO4556, BO4565, BO4566 	Directly connected	 <p>Extraction point (comes along with the machine)</p> <p>Hose with front cuff</p>	C DVC860L / 150L 
Random Orbit Sander BO5030, BO5041 BO6030 BO6040, DBO180 	Directly connected		D DVC265 / DVC665 
			E DVC350 
			F DVC750L 

POWER TOOLS	SUCTION DEVICE		EXTRACTION UNITS WITH HOSE & CUFFS
Random Orbit Sander BO6050 	 <p>24</p>	 <p>Hose with front cuff</p> <p>Rubber front cuff 24</p> <p>Extraction point (comes along with the machine)</p>	A VC3210LX1 / VC3211HX1 
Drywall Sander DSL800 			
Aluminum Groove Cutter CA5000XJ 	 <p>24</p>	 <p>Rubber front cuff 24</p> <p>Hose with front cuff</p> <p>Extraction point (comes along with the machine)</p>	B DVC864L / DVC154L 
Plunge cut circular saw SP6000 DSP600 DSP601 	 <p>24</p>	 <p>Hose with front cuff</p> <p>Rubber front cuff 24</p> <p>Extraction point (comes along with the machine)</p>	C DVC860L / DVC150L 
Circular Saw HS004G, DHS900 			
Rear handle saw DRS780 			
Circular Saw  <p>DHS660/ DHS661 DHS680 DHS783, HS7010 HS0600</p>	Joint (Dust nozzle) 199230-9 196952-2 196520-1 198263-1 +  <p>24</p> 	 <p>Rubber front cuff 24</p> <p>Joint</p> <p>Extraction point (comes along with the machine)</p>	E DVC350 
Jig Saw JV103D, JV102D 	Joint (Dust nozzle) 457801-1 +  <p>24</p> 	 <p>Rubber front cuff 24</p> <p>Joint</p>	F DVC750L 

38 Front cuff 38 (used with 28mm dia hose)













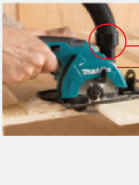





22 Front cuff 22 (used with 28mm dia hose)

38 Fixed front cuff 38 (comes with 38mm dia Hose)











22-38 Joint

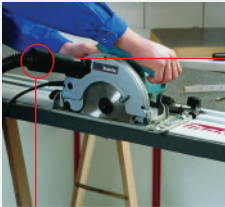





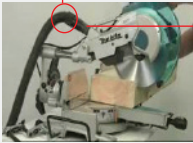

38 Fixed front cuff 38 (Flexible hose for DVC750L)

24 Rubber front cuff 24

POWER TOOLS	SUCTION DEVICE		EXTRACTION UNITS WITH HOSE & CUFFS
Circular Saw  DSS610 HS301D	Joint  419283-5 452237-9	 Hose with front cuff Joint	<div style="border-bottom: 1px solid black; padding: 5px;"> A VC3210LX1 / VC3211HX1  </div> <div style="border-bottom: 1px solid black; padding: 5px;"> B DVC864L / 154L  </div> <div style="border-bottom: 1px solid black; padding: 5px;"> C DVC860L / 150L  </div> <div style="border-bottom: 1px solid black; padding: 5px;"> D DVC265 / DVC665  </div> <div style="border-bottom: 1px solid black; padding: 5px;"> E DVC350  </div> <div style="padding: 5px;"> F DVC750L  </div>
Plate Joiner PJ7000, 3901 DPJ180	Directly connected	 Extraction point (comes along with the machine) Hose with front cuff	
Jig Saw JV100D, JV101D, JV183D, 4326, 4327, 4328, 4329	Directly connected	 Hose with front cuff	
Jig Saw DJV180, 4350CT/FCT, 4351FCT	Dust nozzle 417853-4 	 Dust nozzle Hose with front cuff	
Drywall Cutter DSD180 SD100D	Directly connected	 Extraction point (comes along with the machine) Hose with front cuff	
Cut-out-Tool 3706 DC0181	Dust collecting cover 193449-2 	 Dust collecting cover Hose with front cuff	
Multi Tool  TM3000C TM3010CK DTM51	Dust attachment 196022-7 196550-2 196765-1 	 Dust attachment Hose with front cuff	



POWER TOOLS	SUCTION DEVICE		EXTRACTION UNITS WITH HOSE & CUFFS
<p>Circular Saw</p>  <p>5143R 5704R N9500N</p>	<p>Joint (Nozzle)</p> <p>192490-2 192420-3 193068-4</p>  <p>(Note: 5143R, 5704R & N9500N fits only to the front cuff 38)</p>	 <p>Joint</p> <p>Hose with Front cuff</p>	<p>A VC3210LX1 / VC3211HX1</p> <p>22 OR 38</p>  <p>B DVC864L / DVC154L</p> <p>22 OR 38</p>  <p>C DVC860L / DVC150L</p> <p>38</p>  <p>D DVC265, DVC665</p> <p>22 OR 38</p>  <p>E DVC350</p> <p>22 OR 38</p>  <p>F DVC750L</p> <p>38</p> 
<p>Slide Compound Saw / LS1219L, LS1019L, DLS211, DLS111</p>	<p>24</p> 		

POWER TOOLS	SUCTION DEVICE		EXTRACTION UNITS WITH HOSE & CUFFS
<p>Slide Compound Saw / Miter Saw / Compound Saw LS0714, LS1016, LS1216, DLS714, DLS713 LS1018L, LS0815FL / LS1440, LS1040 / DLS600</p> 	<p>Directly connected</p>	<p>Hose with front cuff</p>  <p>Extraction point (comes along with the machine)</p>	<p>A VC3210LX1 / VC3211HX1</p> <p>38</p>  <p>B DVC864L, DVC154L</p> <p>38</p>  <p>C DVC860L, DVC150L</p> <p>38</p>  <p>E DVC350</p> <p>38</p>  <p>F DVC750L</p> <p>38</p> 
<p>Table Top Miter Saw LH1201FL, LH1040</p> 			
<p>Flip Over Saw LF1000</p> 	<p>Directly connected</p>	<p>Hose with front cuff</p>  <p>Extraction point (comes along with the machine)</p>	

38 Front cuff 38 (used with 28mm dia hose)





















22 Front cuff 22 (used with 28mm dia hose)





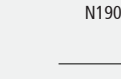

38 Fixed front cuff 38 (comes with 38mm dia Hose)

22-38 Joint

38 Fixed front cuff 38 (Flexible hose for DVC750L)

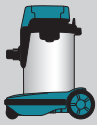
24 Rubber front cuff 24

POWER TOOLS	SUCTION DEVICE		EXTRACTION UNITS WITH HOSE & CUFFS
Router  RP1800/F, RP2300FC DRT50, RP0900, RT0700C for RT0700C: Use with plunge base assembly	Nozzle 194934-8 194733-8 	 Hose with front cuff Nozzle	Makita recommends to use 38mm dia hose when using router, trimmer and planer A VC3210LX1 / VC3211HX1 
Trimmer RT0700C 	Nozzle 195559-1 		B DVC864L, DVC154L 
Power Planer DKP180 	Nozzle 451329-1 	 Hose with front cuff Nozzle	C DVC860L, DVC150L 
Power Planer 1911B 	Nozzle 192082-7 	 Hose with front cuff Nozzle	D DVC265, DVC665 
Power Planer 1805N 	Nozzle + Joint JPA122277 (nozzle)+ 181575-9 (joint)		E DVC350  DVC350 cannot be used with Power Planer models
N1900B, N1923B 	181572-5 (nozzle)+ JPA122275 (joint)		F DVC750L 
KP0800XK 	451329-1(nozzle) + 416368-8 (elbow)		
Power Planer DKP181, KP0810 	Directly connected		

POWER TOOLS	SUCTION DEVICE		EXTRACTION UNITS WITH HOSE & CUFFS
Table Saw  MLT100 2703 2704 2712	Joint  JM27000090 192799-2 419093-0 Directly connected		A VC3210LX1 / VC3211HX1 
Band Saw LB1200F 	Dust point 419093-0		B DVC864L, DVC154L 
			C DVC860L, DVC150L 

38 Front cuff 38 (used with 28mm dia hose)

22 Front cuff 22 (used with 28mm dia hose)

38 Fixed front cuff 38 (comes with 38mm dia Hose)

22-38 Joint

38 Fixed front cuff 38 (Flexible hose for DVC750L)

24 Rubber front cuff 24

High Pressure Washer

Makita-built powerful 1,800 W series motor provides up to 13 MPa for maximum cleaning power



10 m high pressure hose for various applications
Long, superflex, scratch-proof, anti-kink

Integrated hose reel for easy storage
(only for HW1300)

On-board storage
for straightforward setup and accessory storage

Pressure adjustable function
for easy and quick control by turning the handle

High and Low Pressure Selection
(only for HW1300)
Low pressure mode enables soft washing of screen door, air conditioner outdoor unit, car, etc

Rear wheels for easy mobility

Powerful, Eco Friendly, Low Vibration

HW1200 / HW1300
HIGH PRESSURE WASHERS

- CORDLESS
- FIXING / FASTENING
- DRILLING / IMPACT DRILLING
- CONCRETE DRILLING / DEMOLITION
- CUTTING [CONCRETE/ MASONRY/ METAL]
- MULTI TOOL
- GRINDING
- SANDING / POLISHING
- SAWING
- ROUTERING / PLANING
- CLEANING
- HEAT GUN / LASERS
- PNEUMATIC TOOLS
- GARDEN TOOLS
- GENERATORS

HW1200
Acc Pg. A196

High Pressure Washer



Makita-built powerful 1,800 W series motor provides up to 12 MPa for maximum cleaning power (Self-Priming Function)

- Pressure adjustable function for easy and quick control by turning the handle
- 420 L/hr max flow rate
- Powerful washing 10 MPa (100 bar) of working pressure (up to 50X as tap water)
- Lightweight and compact, middle class power washer



Specifications:-

Continuous rating input	1,800W
Max Pressure	12 MPa (120 bar, 1,740 PSI)
Max Flow Rate	420 L/h
Max Feed Temperature	40 °C (104 °F)
High Pressure Hose Length	10 m (33 ft.)
Sound Pressure Level	72 dB(A)
Vibration Level	4.11 m/s ²
Dimensions (L x W x H)	292x358x830 mm
Net weight	11.0 kg
Power supply cord	5.0 m

Standard Equipment: Trigger Gun, Vario-Power Spray Lance, Cyclone jet nozzle, Detergent Bottle, Cleaner Pin, Coupling Sleeve, High Pressure Hose 10 m, Water Hose Connector, Foam Nozzle, Connector

HW1300
Acc Pg. A196

High Pressure Washer

Makita-built powerful 1,800 W series motor provides up to 13 MPa for maximum cleaning power (Self-Priming Function)

- Pressure adjustable function and low noise mode
- Pressure adjustable function for easy and quick control by turning the handle
- Low noise mode enables soft washing of screen door, air conditioner outdoor unit, car, etc.
- 450 L/hr max flow rate

Specifications:-

Continuous rating input	1,800W
Max Pressure	13 MPa (130 bar, 1,885 PSI)
Max Flow Rate	420 L/h
Max Feed Temperature	40 °C (104 °F)
High Pressure Hose Length	10 m (33 ft.)
Sound Pressure Level	76 dB(A)
Vibration Level	4.86 m/s ²
Dimensions (L x W x H)	292x358x830 mm
Net weight	12.7 kg
Power supply cord	5.0 m

Standard Equipment: Trigger Gun, Vario-Power Spray Lance, Cyclone jet nozzle, Detergent Bottle, Cleaner Pin, Coupling Sleeve, High Pressure Hose 10 m, Water Hose Connector, Foam Nozzle, Connector

- CORDLESS
- FIXING / FASTENING
- DRILLING / IMPACT DRILLING
- CONCRETE DRILLING / DEMOLITION
- CUTTING [CONCRETE/ MASONRY/ METAL]
- MULTI TOOL
- GRINDING
- SANDING / POLISHING
- SAWING
- ROUTERING / PLANING
- CLEANING
- HEAT GUN / LASERS
- PNEUMATIC TOOLS
- GARDEN TOOLS
- GENERATORS



HW131 Acc Pg. A196

High Pressure Washer



Must be used lying down

- Ideal for industrial users.**
- Is fitted with a Triplex pump with ceramic coated pistons controlled by connecting a rod system for heavy duty tasks and prolonged use.
 - It is equipped with a wheeled trolley for easy moving and an integrated accessory holder for easy storage.
 - It also has a water filter, an induction electric motor as well as an adjustable spray head with high/low pressure with pencil/fan jet settings.

Specifications:-

Maximum Pressure	Max 130 bar
Maximum Flow	500 L/hr
Induction Motor	2,3 kW 230V 50Hz
Hose Length	15m
Net Weight	33kg

Standard Equipment: Gun and Lance with Hi/Low and Pencil/fan Adjustable Nozzle, Rotopower Turbo Lance, On Board Detergent Tank, Pressure Gauge, Triplex Plunger Pump with Connecting Rod System.

HW132 Acc Pg. A196

High Pressure Washer



- Ideal for industrial users.**
- Built-in accessories holder.
 - Rubber tread wheels.
 - Built-in hose reel.
 - Quick connection accessories and steel armed hose.

Specifications:-

Maximum Pressure	Max 140 bar
Maximum Flow	420 L/hr
Induction Motor	2,1 KW
Hose Length	8m
Net Weight	15.5kg

Standard Equipment: Gun (metal type), Adjustable Spray Lance and Detergent Head.

HW151 Acc Pg. A196

High Pressure Washer



- Ideal for industrial users.**
- Built-in accessories holder.
 - Rubber tread wheels.
 - Built-in hose reel.
 - Swivel connection accessories, Steel armed hose.
 - Brass head / Steel frame.

Specifications:-

Maximum Pressure	Max 150 bar
Maximum Flow	500 L/hr
Induction Motor	2,5 kW
Hose Length	10m
Net Weight	26.9 kg

Standard Equipment: Gun (metal type), Adjustable Spray Lance and Detergent head.

Heat Gun



- CORDLESS
- FIXING / FASTENING
- DRILLING / IMPACT DRILLING
- CONCRETE DRILLING / DEMOLITION
- CUTTING [CONCRETE/ MASONRY/ METAL]
- MULTI TOOL
- GRINDING
- SANDING / POLISHING
- SAWING
- ROUTERING / PLANING
- CLEANING
- HEAT GUN / LASERS
- PNEUMATIC TOOLS
- GARDEN TOOLS
- GENERATORS

Acc Pg. A198

HG6030K

Heat gun



New design with easy-to-operate slide switch

- 1,800W class
- Temperature Settings / Stages: Slide Switch / 2 Stages plus cooling mode
- Airflow setting Slide switch / 3 stages (temperature setting activated)
- Ergonomic soft rubber grip design for comfortable operation
- Various optional nozzles

Specifications:- 

Continuous rating input	1,800W
Air Temperature (°C) / Flow (L/min)	Switch 1: 50 / 250 Switch 2: 300 / 250 Switch 3: 600 / 500
Dimensions (L x W x H)	233x80x208 mm
Net weight	0.57 kg
Power supply cord	2.0 m

Standard Equipment: Comes with carry case. (Nozzles does not comes with the tool)

Acc Pg. A198

HG6531CK

Heat gun



New design with Preset function and liquid crystal display

- 2,000W class
- Temperature Settings / Adjustment interval : Push button switch / by every 5° C.
- Airflow setting: Push button / 5 stages
- Preset function - Depending on intended use, you can recall the saved settings and easily set the temperature and air flow volume.
- The name of each setting is displayed on the LCD screen.
- Various optional nozzles



Specifications:- 

Continuous rating input	2,000W
Air Temperature (°C)	50 - 650
Air Flow	200 - 550 L/min
Dimensions (L x W x H)	253x85x205 mm
Net weight	0.72 kg
Power supply cord	2.0 m

Standard Equipment: Includes various types of nozzles. Comes with carry case.

Acc Pg. A198

HG6530V

New design with Variable temperature heat gun with LCD Digital Display

- 2,000W class
- Ideal for vehicle wraps and tinting, stripping lacquer, paint and varnish, thawing frozen pipes, loosening tile and putty, re-melting adhesive, removing stickers, waxing and de-waxing, bending plastic pipes and sheets, and more
- Various optional nozzles

Specifications:- 

Continuous rating input	2,000W
Air Temperature (°C)	50 - 650
Air Flow	Stage 1: 280 L/min Stage 2: 280 L/min Stage 3: 550 L/min
Dimensions (L x W x H)	253x85x205 mm
Net weight	0.73 kg
Power supply cord	2.0 m

Nozzles and carry case does not comes with the tool

PRECISION
Push-button temperature control (50-650 °C) for precise control over a variety of applications



VERSATILITY
Slide switch sets three air flow settings (cooling, low, high) for greater versatility



DESIGN
Rubberized handle and integrated rear stand



CONVENIENCE
Built-in tether notch (tether sold separately)



Laser

Laser Distance Measures, Rotary Laser, Cross line Laser



Line beam brightness selection (Bright mode and Eco mode)

Rechargeable Red Cross Line Laser

Cross line + Point
SK106D

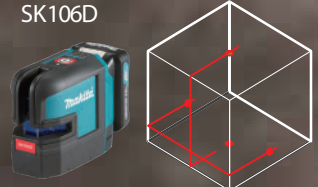

2 - LINES (Horizontal line / Vertical line)
4 - POINTS (Left/Right/Upper/Lower directions)

Cross line
SK105D



2 - LINES (Horizontal line and Vertical line)

Rechargeable Green Cross Line Laser

Cross line + Point
SK106GD



2 - LINES (Horizontal line / Vertical line)
4 - POINTS (Left/Right/Upper/Lower directions)

Cross line
SK105GD



2 - LINES (Horizontal line and Vertical line)

- CORDLESS
- FIXING / FASTENING
- DRILLING / IMPACT DRILLING
- CONCRETE DRILLING / DEMOLITION
- CUTTING [CONCRETE/ MASONRY/ METAL]
- MULTI TOOL
- GRINDING
- SANDING / POLISHING
- SAWING
- ROUTERING / PLANING
- CLEANING
- HEAT GUN / LASERS
- PNEUMATIC TOOLS
- GARDEN TOOLS
- GENERATORS

SK106GD
Acc Pg. A199

12V MAX CXT Lithium-ion Rechargeable 4-point Cross Line Laser

GREEN

Bright 525nm class II green laser with measuring range upto 35m and with 3±mm / 10m for best-in-class accuracy

- High brightness green laser for increased visibility at bright site
- External Power Supply Jack for LXT Battery Use
- Line visibility range up to 35 m / 80 m (with Receiver)
- Pendulum lock enables slope incline applications for increased versatility; Offers added protection of laser diode during transport and storage

Specifications:-

Measuring range	Up to: 35 m
Measuring range w/ detector	Up to: 80 m
Leveling accuracy	±3 mm / 10 m
Self-leveling range	±4°
Laser fan angle	Horizontal: 180° / Vertical: 170°
Number of laser points / Lines	4 / 2
Laser type	Laser class 2: 525 nm
Operating temperature	-10 - 50 °C
Operating Time (Approx. Hours)	7 - 20hrs
Dimensions (L x W x H)	138x64x102 mm (with 2.0Ah battery)
Net weight	0.48kg (without battery)

Standard Equipment:

Soft bag, Adapter, Target Plate

AVAILABLE VARIANTS		
4.0Ah	2.0Ah	"Z" Version
		SK106GD Z TOOL ONLY (DOES NOT INCLUDE BATTERY / CHARGER OR CARRY CASE)

SK106D
Acc Pg. A199

12V MAX CXT Lithium-ion Rechargeable 4-point Cross Line Laser

RED

Bright 635nm class II red laser with measuring range upto 25m and with 3±mm / 10m for best-in-class accuracy

- External Power Supply Jack for LXT Battery Use
- Line visibility range up to 35 m / 80 m (with Receiver)
- Pendulum lock enables slope incline applications for increased versatility; Offers added protection of laser diode during transport and storage

Specifications:-

Measuring range	Up to: 25 m
Measuring range w/ detector	Up to: 80 m
Leveling accuracy	±3 mm / 10 m
Self-leveling range	±4°
Laser fan angle	Horizontal: 180° / Vertical: 170°
Number of laser points / Lines	4 / 2
Laser type	Laser class 2: 635nm
Operating temperature	-10 - 50 °C
Operating Time (Approx. Hours)	15 - 40hrs
Dimensions (L x W x H)	138x64x102 mm (with 2.0Ah battery)
Net weight	0.48kg (without battery)

Standard Equipment:

Soft bag, Adapter, Target Plate

AVAILABLE VARIANTS		
4.0Ah	2.0Ah	"Z" Version
		SK106D Z TOOL ONLY (DOES NOT INCLUDE BATTERY / CHARGER OR CARRY CASE)

SK105GD
Acc Pg. A199

12V MAX CXT Lithium-ion Rechargeable Cross Line Laser

GREEN

Bright 525nm class II green laser with measuring range upto 35m and with 3±mm / 10m for best-in-class accuracy

- High brightness green laser for increased visibility at bright site
- External Power Supply Jack for LXT Battery Use
- Line visibility range up to 35 m / 80 m (with Receiver)
- Pendulum lock enables slope incline applications for increased versatility; Offers added protection of laser diode during transport and storage

Specifications:-

Measuring range	Up to: 35 m
Measuring range w/ detector	Up to: 80 m
Leveling accuracy	±3 mm / 10 m
Self-leveling range	±4°
Laser fan angle	Horizontal: 180° / Vertical: 160°
Number of laser lines	2
Laser type	Laser class 2: 525 nm
Operating temperature	-10 - 50 °C
Operating Time (Approx. Hours)	7 - 20hrs
Dimensions (L x W x H)	138x64x102 mm (with 2.0Ah battery)
Net weight	0.46 kg (without battery)

Standard Equipment:

Soft bag, Adapter, Target Plate

AVAILABLE VARIANTS		
4.0Ah	2.0Ah	"Z" Version
		SK105GD Z TOOL ONLY (DOES NOT INCLUDE BATTERY / CHARGER OR CARRY CASE)

SK105D
Acc Pg. A199

12V MAX CXT Lithium-ion Rechargeable Cross Line Laser

RED

Bright 635nm class II red laser with measuring range upto 25m and with 3±mm / 10m for best-in-class accuracy

- External Power Supply Jack for LXT Battery Use
- Line visibility range up to 35 m / 80 m (with Receiver)
- Pendulum lock enables slope incline applications for increased versatility; Offers added protection of laser diode during transport and storage

Specifications:-

Measuring range	Up to: 25 m
Measuring range w/ detector	Up to: 80 m
Leveling accuracy	±3 mm / 10 m
Self-leveling range	±4°
Laser fan angle	Horizontal: 180° / Vertical: 160°
Number of laser lines	2
Laser type	Laser class 2: 635nm
Operating temperature	-10 - 50 °C
Operating Time (Approx. Hours)	15 - 40hrs
Dimensions (L x W x H)	138x64x102 mm (with 2.0Ah battery)
Net weight	0.46 kg (without battery)

Standard Equipment:

Soft bag, Adapter, Target Plate

AVAILABLE VARIANTS		
4.0Ah	2.0Ah	"Z" Version
		SK105D Z TOOL ONLY (DOES NOT INCLUDE BATTERY / CHARGER OR CARRY CASE)

Rechargeable Green Multi Line Laser

SK312GD

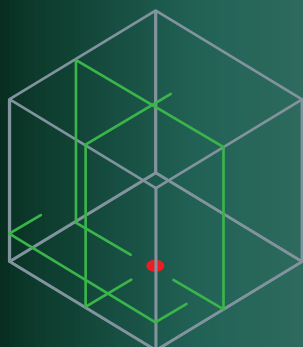

3-vertical line

High brightness green laser for increased visibility at bright site

High brightness green laser

for increased visibility at bright site

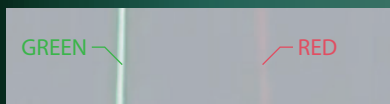

Long continuous operation

at max output

15 / 10h

BL1016

20 / 14h

BL1021B

40 / 28h

BL1041B

allows to be charged from LXT batteries by using USB adapter ADP05 and power supply cable 199006-4



Adapter for USB ADP05
Power supply cable 199006-4

Large handle
prevents the tool from falling.

Fine adjustment knob
fine-adjusted from either side by turning fine-adjustment knob

Adjustment screw leg
Horizontal line can be adjusted at any places



CORDLESS

FIXING / FASTENING

DRILLING / IMPACT DRILLING

CONCRETE DRILLING / DEMOLITION

CUTTING [CONCRETE/ MASONRY/ METAL]

MULTI TOOL

GRINDING

SANDING / POLISHING

SAWING

ROUTERING / PLANING

CLEANING

HEAT GUN / LASERS

PNEUMATIC TOOLS

GARDEN TOOLS

GENERATORS

SK312GD

Acc Pg. A198

Laser

12V max CXT Li-Ion Rechargeable Green Multi Line Laser

High Brightness Green Laser for Increased Visibility at Bright Site
Horizontal line / horizontal/vertical line / 3-vertical line/horizontal line (Loopback switch system)
High accuracy +/- 1 mm @ 10 m
Up to 28 hours of continuous illumination in high visibility mode with BL1041B
Self-Leveling Horizontal/Vertical Cross Line laser

Standard Equipments: Glasses for laser, Shoulder Belt, Storage Case

Available variant: SK312GDZ (Battery and charger dose not comes with the Laser)

Leveling accuracy	±1 mm / 10 m
Self-leveling range	±2°
Laser fan angle	Horizontal: 110° Vertical: 130°
Number of laser lines	3
Laser type	Laser class 2: 515 nm
Operating temperature	-10 - 40 °C
Tripod thread	5/8"
Protection class	IP54
Operating Time (Approx. Hours)	10-28
Dimensions (L x W x H)	w/ BL1041B: 122x130x225 mm
Net weight	1.6 kg



12 V max Lithium-ion Battery



- CORDLESS
- FIXING / FASTENING
- DRILLING / IMPACT DRILLING
- CONCRETE DRILLING / DEMOLITION
- CUTTING [CONCRETE/ MASONRY/ METAL]
- MULTI TOOL
- GRINDING
- SANDING / POLISHING
- SAWING
- ROUTERING / PLANING
- CLEANING
- HEAT GUN / LASERS / GENERATORS
- PNEUMATIC TOOLS
- GARDEN TOOLS
- HAND TOOLS / COMBINATION SETS

Makita LD050P and LD080PI

These compact and handy models are specifically designed for indoor applications. Shortcut keys for addition, subtraction, area and volume calculation make measuring fast and very reliable. The last 5 or 20 measurements are also automatically stored depending on model. The laser dot is clearly visible. You can always see your targeting point, even if the target object is in a hard to access area.



Robust End Piece

The LD080P and LD080PI end pieces are strong and rugged, offering excellent support when measuring from corners or edges. Position 1 offers a solid piece to butt up against edges, while position 2 provides ultimate accuracy when measuring from corners.



Swiss Built Optics

Swiss precision optics and a sturdy titanium inner housing have been used in all models in order to give clear focusing of the laser over long distances, resistance to wear and tear on the building site and temperature change.

Explanations

	Typical Measuring Accuracy	2.0mm	1.5mm
Single Distance	●	●	●
Max / Min Distance	●	●	●
Add / Subtract	●	●	●
Area Calculation	●	●	●
Volume Calculation	●	●	●
Tracking Function	●	●	●
Pythagoras (2 point) - A	●	●	●
Pythagoras (3 point) - B	●	●	●
Partial Height - C	●	●	●
Timer Function	●	●	●
Corner Measuring Pin	●	●	●
Memory	5	5	20
Incline Measurement - D	●	●	●
Height Tracking	●	●	●
Stake Out	●	●	●



Acc Pg. A199

LD050P

Laser Distance Measure

Compact, handy, and accurate

- New angle measuring method

Specifications:-

Measuring Range	0.05m-50m
Power supply	Cell battery : AAA 15V x 2pcs
Net weight	0.1kg (0.22lbs)

Standard Equipment: Alkaline battery x2, Carrying strap, Target plate

Acc Pg. A199

LD080PI

Laser Distance Measure

Compact, handy, and accurate

- New angle measuring method
- With inclination sensor

Specifications:-

Measuring Range	0.05m-80m
Power supply	Cell battery : AAA 15V x 2pcs
Net weight	0.14kg (0.31 lbs)

Standard Equipment: Alkaline battery x2, Carrying strap, Target plate

LD030P

Acc Pg. A199

Laser Distance Measure



Compact, handy and specially designed for indoor applications

- Laser dot clearly visible up to 30M
- Functions: Single Measurement
- Tracking function
- Area calculation

3 Mode

Single measurement **ON**

Tracking function **ON** 2sec.

Area calculation **UNIT**

Quick & easy automatic area calculation.

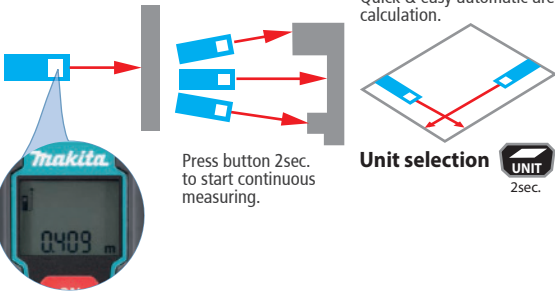

Precise measurement



Measuring Range
0.2 - 30m

Protection Class
IP54

Specifications:-

Measuring Range	0.2 - 30 m
Storage temperature range	-25 - 70 degrees
Typical measuring tolerance	±2.0mm / 10m
Max measuring tolerance	±3.0mm / 10m
Diameter of laser point	6mm / 10m
Laser type	(Laser class 2) : 635nm
Dimensions	115x53x25mm
(H x D x W)	(4-1/2" x 2-1/16" x 1")
Net weight	0.09kg

Standard Equipment: AAA 2x1.5V batteries

SKR301

Acc Pg. A199

Rotating Laser Level

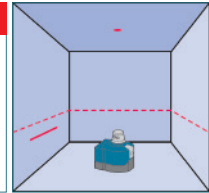

Automatic operation in both horizontal and vertical modes

- Superior leveling range.
- Choice of beams : spot, chalk line or Plumb line.
- Variable rotation speed.

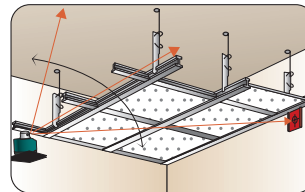
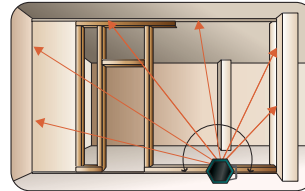
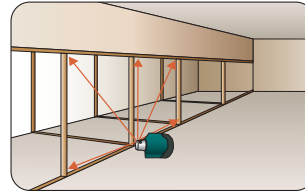
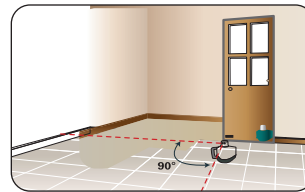
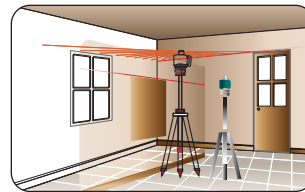

Specifications:-

Measuring range	15m
Measuring range with detector	30m
Rotation Speed	0-535rpm
Leveling accuracy	+ - 10mm / 100m
Leveling range	+ - 8°
Power supply	Cell battery : 2pcs
Operating time (approx. hrs)	160

Standard Equipment: Remote control, CB60 Magnetic Target, Laser Intensive Glasses, Rechargeable (Ni-Cd) 2D Alkaline x 2 and Charger

CORDLESS

FIXING / FASTENING

DRILLING / IMPACT DRILLING

CONCRETE DRILLING / DEMOLITION

CUTTING [CONCRETE/ MASONRY/ METAL]

MULTI TOOL

GRINDING

SANDING / POLISHING

SAWING

ROUTERING / PLANING

CLEANING

HEAT GUN / LASERS / GENERATORS

PNEUMATIC TOOLS

GARDEN TOOLS

HAND TOOLS / COMBINATION SETS

SK102Z

Acc Pg. A199

Cross Line Laser Level



Self levelling

Horizontal and vertical self-levelling up to $\pm 4^\circ$, when out of levelling range automatically switches off laser and shows warning light

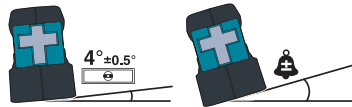

Horizontal aligning

Spirit levels and string lines are a thing of the past; now the SK102Z is the convenient way to transfer reference points from one wall to another

Vertical aligning

The simple way to ensure that wall and floor tile joints precisely meet one another.

Exact 90 degree angle

Alignment tasks such as marking out 90 degree angles are done at the touch of a button. Saving you real time!

Aligning at an angle

You can manually switch off the self-levelling feature using the lock function. The laser line can then be projected at any angle. The lock function also serves as transport protection.

Working in very bright conditions

The pulse function is not just an energy-saving mode: it also allows you to locate the laser lines using a laser detector, even in very bright lighting conditions.

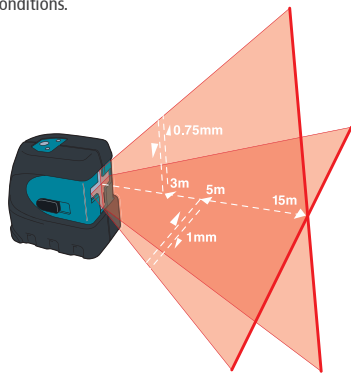

Specifications:-



Measuring Range	Up to 15m with detector Up to 30m
Leveling accuracy	$\pm 3\text{mm} / 10\text{m}$
Measuring Range	30m
Power supply	Cell battery : AA 1.5V x 3pcs
Net weight	0.32kg (0.7lbs)

Standard Equipment: Soft bag, 3 AA batteries, Laser target plate and magnetic simple wall mount

SK103PZ

Acc Pg. A199

4-Point Cross line Laser Level

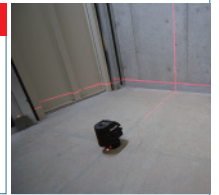

Self-levelling combination cross-line/ Point laser

- Provides all possible reference lines required in leveling, aligning, plumbing and squaring applications for maximum versatility.
- Line visibility range up to 15mm and Pulse Function for long distance usage up to 60m with detector.
- Water and dust proof.

Capacity

Extended laser line fan length spans well past 90 degree point position.

Accuracy

Can self-level all surfaces with a tolerance of ± 4.0 degrees and has an accuracy of ± 0.3 degrees.

Durability

Integrated Pendulum Lock offers added protection of laser diode during transport and storage.

Versatility

All-in-one solution combination laser provides all possible reference lines and points.

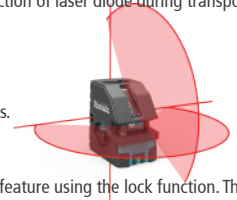

Aligning at an angle

You can manually switch off the self-levelling feature using the lock function. The laser line can then be projected at any angle. The lock function also serves as transport protection.

Working in very bright conditions

The pulse function is not just an energy-saving mode: it also allows you to locate the laser lines using a laser detector, even in very bright lighting conditions.

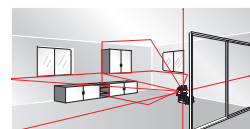
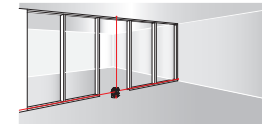
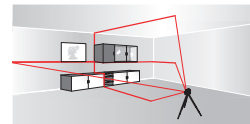

Specifications:-

Measuring Range	Up to 15m with detector Up to 60m
Leveling accuracy	$\pm 3\text{mm} / 10\text{m}$
Self-levelling range	4 ± 1 degrees
Horizontal fan angle	180 degrees
Vertical fan angle	180 degrees
Number of laser points	4
Number of laser lines	2
Laser type	(Laser class 2) : 635nm
Operating temperature range	-10 - 40 degrees
Storage temperature range	-25 - 70 degrees
Tripod thread	1/4"
Protection class	IP54
Net weight	0.53kg

Standard Equipment: Adapter (magnetic), Target plate, AA 1.5V batteries, Pouch with strap

Pneumatic Tools

Stapler, Pinner, Brad Nailer, Coil Nailer



- CORDLESS
- FIXING / FASTENING
- DRILLING / IMPACT DRILLING
- CONCRETE DRILLING / DEMOLITION
- CUTTING [CONCRETE/ MASONRY/ METAL]
- MULTI TOOL
- GRINDING
- SANDING / POLISHING
- SAWING
- ROUTERING / PLANING
- CLEANING
- HEAT GUN / LASERS
- PNEUMATIC TOOLS
- GARDEN TOOLS
- GENERATORS

AT1025B
Acc Pg. A201

Pneumatic Stapler



Accurate and precise

- Durable and lightweight die cast housing.
- 360 degrees multi-direction exhaust ports.
- Rubber handle.
- Uses 20 gauge staples from 13/32" to 1" (10 mm to 25 mm), crown size 1/5" (5.1mm).

Specifications:-

Operating air pressure	65 PSIG (4.5 kgf / cm ² G)
Staple size	Crown : 11.2mm (7/16")
	Width : 1.16mm (0.046")
	Thickness : 0.56mm (0.022")
	Gauge : 20
	Length : 10 - 25 mm (13/32" - 1")
Staple capacities	100
Overall length	250 mm (9-7/8")
Net weight	1.3 kg (2.86 lbs)

Standard Equipment: Oil Supply, Hex Wrench

AT1225BZ
Acc Pg. A201

Pneumatic Stapler



Accurate and precise

- Durable and lightweight die cast housing.
- 360 degrees multi-direction exhaust ports.
- Rubber handle.
- Uses 21 gauge staples from 13/32" to 1" (10 mm to 25 mm), crown size 1/5" (5.1mm).

Specifications:-

Operating air pressure	60 PSIG (4 kgf / cm ² G)
Staple size	Crown : 12.95mm (1/2")
	Width : 0.95mm (0.037")
	Thickness : 0.66 mm (0.026")
	Gauge : 21
	Length : 10 - 25 mm (13/32" - 1")
Staple capacities	100
Overall length	250mm (9-7/8")
Net weight	1.3kg (2.86 lbs)

Standard Equipment: Oil Supply, Hex Wrench

AT425B
Acc Pg. A201

Pneumatic Stapler



Robust - uses 20 Gauge staples

- Durable and lightweight die cast housing.
- 360 degree multi-direction exhaust ports.
- Rubber handle.
- Uses 20 gauge staples from 13/32" to 1" (10 mm to 25 mm), crown size 1/5" (5.1mm).

Specifications:-

Operating air pressure	65 PSIG (4.5 kgf / cm ² G)
Staple size	Crown : 5.1mm (0.20")
	Width : 1.14mm (0.045")
	Thickness : 0.58mm (0.023")
	Gauge : 20
	Length : 10 - 25 mm (13/32" - 1")
Staple capacities	100
Overall length	250 mm (9-7/8")
Net weight	1.3 kg (2.86 lbs)

Standard Equipment: Oil Supply, Hex Wrench

AF301
Acc Pg. A202

Pneumatic Brad Nailer



Accurate high caliber nailer

- Durable and lightweight die cast housing
- 360 degree multi-direction exhaust ports
- Rubber handle
- Uses 18 gauge brad nails from 13/32" to 1-3/16" (10 mm to 30 mm)

Specifications:-

Operating air pressure	65 PSIG (4.5 kgf / cm ² G)
Nail size	Head : 2.0 mm (0.079")
	Shank width : 1.25mm (0.050")
	Shank thickness : 1.05mm (0.041")
	Gauge : 18
	Length : 10 - 30 mm (13/32" - 1-3/16")
Nail capacities	100
Overall length	250 mm (9-7/8")
Net weight	1.3kg (2.86 lbs)

Standard Equipment: Oil Supply, Hex Wrench

AF506

Acc Pg. A202

Pneumatic Brad Nailer



18 Ga 50 mm (2") Pneumatic Brad Nailer

- Durable and compact design with ease-of-use features
- Narrow nose design allows easy nailing access in confined areas
- "Tool-less" easy to clear nose for fast and easy nail extraction
- Easy to use "tool-less" depth adjustment dial for a wide variety of finish applications
- Built-in air duster provides convenient air flow to clear work surface
- Multi-directional exhaust port rotates 360° to direct exhaust air away from user.
- The cast-and-machined nose piece is engineered for precise contact with the workpiece, with a non-marring rubber nose engineered to protect the work surface.
- Ideal for trim work, baseboard and crown molding installation, flooring and other woodworking applications
- Dual nail reload indicator window alerts the user when to reload nails to avoid blank drives

Specifications:-



Capacity	Length: 15 - 50 mm (5/8" - 2") Gauge: 18 Ga
Operating Pressure	0.49 - 0.83 MPa (70 - 120 PSI)
Magazine Capacity	100
Dimensions (L x W x H)	250x70x256 mm
Net weight	1.3 kg

Standard Equipment: Oil Supply, Safety Goggles, Nose Adapter, Hook

AN613

Acc Pg. A202

Pneumatic Coiler Nailer



Pneumatic coil nailer powered by normal pressure air

- Efficient motor and trigger design offers leading fastening performance
- "Tool-less" depth adjustment
- 2-mode selector switch; single sequential mode and contact actuation mode
- Smooth nose tip prevents scratching
- Multi-directional exhaust port directs exhaust air away from operator
- Reversible belt hook allows the tool to remain close
- Clear loading canister with nail size adjustment allows user to quickly view the nails
- Anti-slip ribs added to the grip rubber provides more control
- Ergonomic rubberized grip for increased comfort on the job
- Built-in air duster provides convenient air flow to clear work materials and tools
- Rubber bumpers protect work surface and tool
- Low noise & Low recoil
- Ideal for installing fiber cement and wood shingle siding, sub-floor framing, exterior nailing, interior nailing, framing

Specifications:-

Capacity	Length: 38 - 65 mm
Nail gauge	Gauge: 2.3 - 2.5 mm 70 - 120 psi
Operating Pressure	0.49 - 0.83 MPa (70 - 120 PSI)
Magazine Capacity	200 - 300
Dimensions (L x W x H)	250x70x256 mm
Net weight	2.2 kg

Standard Equipment: Safety Goggles, Nose Adapter, Hook, Hex Wrench

AF201Z

Acc Pg. A202

Pneumatic Micro Pinner



Precision and accuracy in every shot

- Durable and lightweight die cast housing
- Rubber handle
- Uses 23 gauge pins from 15/32" to 1" (12 mm to 25 mm)

Specifications:-



Operating air pressure	65 PSIG (4.5 kgf / cm ² G)
Pin size	Gauge : 23 (0.63 mm) (0.025") Length : 12 - 25 mm (15/32" - 1")
Pin capacities	100
Overall length	240 mm (9.6")
Net weight	0.9 kg (1.98 lbs)

Standard Equipment: Oil Supply, Hex Wrench



CORDLESS

FIXING / FASTENING

DRILLING / IMPACT DRILLING

CONCRETE DRILLING / DEMOLITION

CUTTING [CONCRETE/ MASONRY/ METAL]

MULTI TOOL

GRINDING

SANDING / POLISHING

SAWING

ROUTERING / PLANING

CLEANING

HEAT GUN / LASERS

PNEUMATIC TOOLS

GARDEN TOOLS

GENERATORS

Garden Tools

Muti Function Power Head, Chain Saw, Hedge Trimmer, Brush Cutter, Grass Trimmer, Edger, Blower, Lawn Mower



Go Green with Makita Lithium-ion Cordless Garden Tools

Best choices for resorts, hotels, public places and among residential areas due to

ZERO EMISSION + **ZERO** POLLUTION + **LOW** NOISE + **LOW** VIBRATION + **EASY** MAINTENANCE

18V X2 (36V)

12V max

14.4V

18V

18V

CXT

Pruning Shears
Lawn Mower
Chain Saw
Hedge Trimmer
Multi Function Power Head
Grass Trimmer
Blower
Hedge Trimmer
Chain Saw
Grass Trimmer
Grass Shear
Recipro Saw
Grass Trimmer
Hedge Trimmer
Grass Shear
String Trimmer
Hedge Trimmer
Blower
Wheelbarrow
Garden Sprayer
Grass Shear





Makita mini 4-Stroke Engine

4-STROKE ENGINE

Reliable and Environment Friendly

High Performance in Compact Design

Makita 4-Stroke Engine delivers high torque and horsepower. Max. Torque and horsepower of Makita 4-Stroke Engine are almost the same as those of an equivalent 2-Stroke engine.

Compared with the conventional 4-Stroke Engines, Makita 4-Stroke Engine produces approximately 20 to 30 % more power thanks to its high combustion efficiency and new developments such as compact spark plug.

Additionally, by employing a unique lubrication system, it has obtained the smallest in class exterior physical dimensions among the 4-Stroke Engines available in the market today.

Patented unique lubrication system enables to use 4-Stroke Engine in full multi-position

Employing this system enables to use 25.4mL Brushcutters on any slope such as ditch slopes, river banks or mountain woods. The natural pressure changes in the crankcase caused by the piston movement in the cylinder are harnessed to pump the oil throughout the engine. Oil is pumped from a reservoir in the base of the engine through a network of one-way valves for reliable lubrication and long service life without the need to keep the engine level.



New compact plug



Valve system

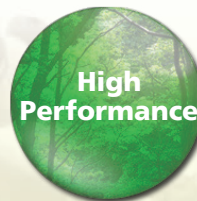
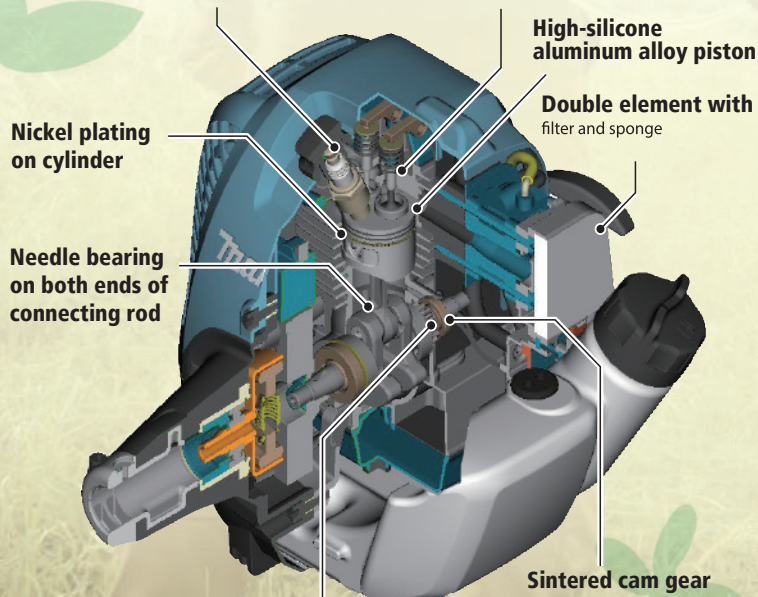

High Performance



Compact



Easy Maintenance



Clean Exhaust Emissions

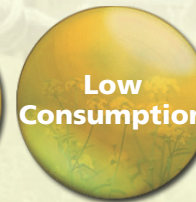

Low Consumption



Low Noise



Decompression System:

The force required to pull the starter rope is drastically reduced by the Automatic decompression system that features our original centrifugal structure in the cam gear.

Multi Function Power Head

Multi Function Power Head designed for wide range of garden and agricultural applications. Multi Function Power Head is for users with multiple garden applications with different attachments. This reduces the need for purchasing multiple tools for different applications thereby saving cost and space.



DUX60
18v+18v Li-ion
Cordless

EX2650LH
Petrol Engine

various optional attachments for all your garden needs

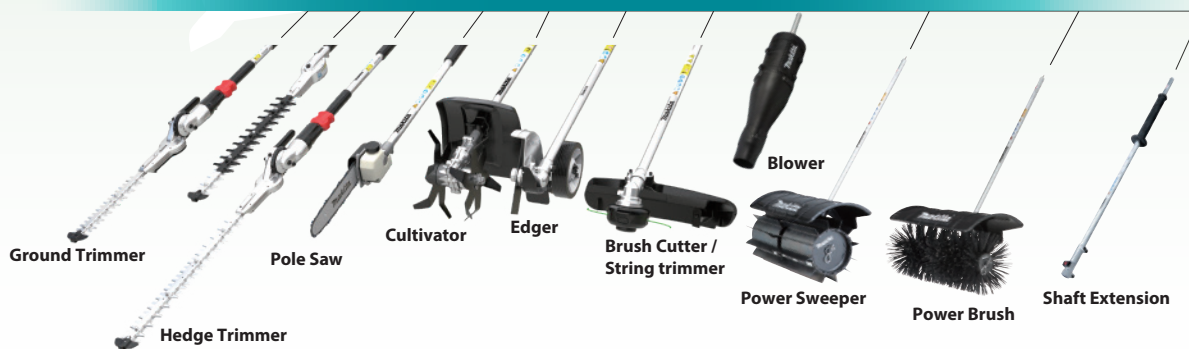

CORDLESS

FIXING / FASTENING

DRILLING / IMPACT DRILLING

CONCRETE DRILLING / DEMOLITION

CUTTING [CONCRETE/ MASONRY/ METAL]

MULTI TOOL

GRINDING

SANDING / POLISHING

SAWING

ROUTERING / PLANING

CLEANING

HEAT GUN / LASERS

PNEUMATIC TOOLS

GARDEN TOOLS

GENERATORS

DUX60

Acc Pg. A204-213

LXT Cordless Multi Function Power Head



18V X2 LXT, BL, AFT, Cordless Multi Function Power Head

- High Power BL Motor Enables to Work under Heavy Load
- High/Medium/Low 3-speed selection and variable speed control by trigger
- Reverse switch for easy removal of grass clippings from the cutting tool
- Multi-tool system consisting of the power head and versatile optional attachments
- Ergonomically designed new loop handle fits comfortably in user's hand

Specifications:-



Max output power: W	600
No Load Speed (RPM)	High: 0 - 9,700 / Medium: 0 - 8,200 / Low: 0 - 5,700
Constant speed control	Yes
Variable speed control	By Trigger + By Button (3-speed selection)
Grass clipping removal function	Yes
Dimensions (L x W x H)	1,011x320x216 mm
Net weight	4.1kg (without battery)

Standard Equipment: Harness, Safety Goggles, Hex Wrench, Accessory Bag

AVAILABLE VARIANTS

5.0Ah	3.0Ah	"Z" VARIANT
-	-	DUX60 Z TOOL ONLY

EX2650LH

Acc Pg. A204-213

Petrol Multi Function Power Head



25.4 mL MM4 Multi Function Power Head

- Environment-friendly and cost-saving 25.4cc 4-stroke engine
- Patented lubrication system enables Makita 4-Stroke Line Trimmers to be used on any angle and slope.
- Multi-tool system consisting of the power head and versatile optional attachments
- Ergonomically designed loop handle with rubberized soft grip
- Makita Mini 4-Stroke motors offer cleaner exhaust emissions and reduced fuel consumption.

Specifications:-



Max output power: W	770
No Load Speed (RPM)	10,000
Constant speed control	No
Variable speed control	By Trigger
Grass clipping removal function	No
Dimensions (L x W x H)	975 x 323 x 241 mm
Net weight	4.6kg

Standard Equipment: Harness, Socket Wrench, Hex Wrench, Oil set, Accessory Bag

- CORDLESS
- FIXING / FASTENING
- DRILLING / IMPACT DRILLING
- CONCRETE DRILLING / DEMOLITION
- CUTTING [CONCRETE/ MASONRY/ METAL]
- MULTI TOOL
- GRINDING
- SANDING / POLISHING
- SAWING
- ROUTERING / PLANING
- CLEANING
- HEAT GUN / LASERS
- PNEUMATIC TOOLS
- GARDEN TOOLS
- GENERATORS

Multi Function Power Head attachment

- Able to meet a wide range of needs with only one power head
- Same accessories as used for EX2650LH



Brush cutter EM400MP (Part no: 195654-7)



The lower section for nylon cutting head can be removed without tool.

- Bump & feed 4
- Cutting width : 420mm
- Dimensions: 876x374x211mm
- Net weight : 1Kg

Standard Equipments:
Nylon cutting head
Hex wrench 5



String trimmer ER400MP (Part no: 195528-2)



- Bump & feed 4
- Dimensions: 703x270x402mm
- Net weight : 0.5Kg

Standard Equipments:
Nylon cutting head
Socket wrench 10-16



Ground trimmer EN420MP (Part no: 198060-5)



Suitable for undergrowth mowing that requires special attention for flying stone or kickback

- Max cutting capacity: 250mm
- Dimensions: 1,324x104x103mm
- Net weight : 2.6kg

Standard Equipments:
Blade cover Socket wrench



Pole Hedge Trimmer (Angle) EN401MP Part no: 196342-9

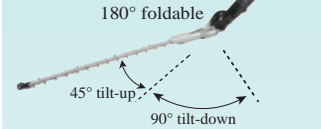

- Max cutting capacity: 490mm
- Teeth: 3 sharpened edges
- Thickness : 2mm
- Tooth spacing: 35mm
- Max branch diameter: 21.5mm
- Dimensions: 1,624 x 108 x 90mm
- Net weight: 2.7Kg

Standard Equipments:
Blade cover, Socket wrench 10



Pole Hedge Trimmer (Straight) EN410MP Part no: 197740-0

Lighter and cost effective than angle adjustable hedge trimmer attachment



- Max cutting capacity: 490mm
- Teeth: 3 sharpened edges
- Thickness : 2mm
- Tooth spacing: 35mm
- Max branch diameter: 22mm
- Strokes per minute: 4200 - 4100spm
- Dimension: 1,104 x 85-71 x 61mm
- Net weight: 1.8Kg

Standard Equipments:
Blade cover, Socket wrench 10



Cultivator KR400MP (Part no: 195713-7)

6pcs - Cleaver-shape claw



Excellent for cultivating small garden beds and between rows of vegetables or flowers

- Cultivating width: 160mm
- Outer dia : 232mm
- Dimensions: 965x235x264mm
- Net weight : 2.9Kg

Standard Equipments:
Hex wrench 5, Torx Wrench



Cultivator KR401MP (Part no: 199188-2)

6pcs - Cleaver-shape claw



Excellent for cultivating small garden beds and between rows of vegetables or flowers

- Cultivating width: 220mm
- No load speed: 230rpm
- Dimensions: 965x235x256mm
- Net weight : 3.2Kg

Standard Equipments:
Torx Wrench

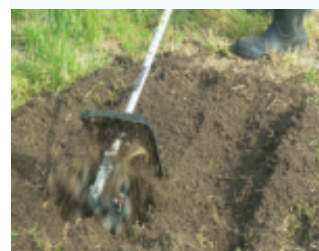

Pole saw EY401MP (Part no: 196104-5)



- Chain oil tank: 0.11L
- Guide bar length: 255mm
- Dimensions: 1,166x80x120mm
- Net weight : 1.1kg

Standard Equipments:
Wrench 8-10, Hex wrench 4
Guide bar cover



**Power Sweeper
SW400MP**

Part no: 199347-8

- Sweeping dust, fallen leaves, or snow on the ground
- If the ground is hard and flat, water can be swept away from the surface



Working width: 590mm
No Load Speed: 230rpm
Outer diameter of Sweep drum: 265mm
Number of Paddle: 12
Dimension (L x W x H): 1,159 x 600 x 362mm
Net weight: 7.2Kg
Standard Equipments: Torx wrench



**Power Brush
BR400MP**

Part no: 199326-6

Cleaning of pavement with many joints and uneven stones using nylon brush

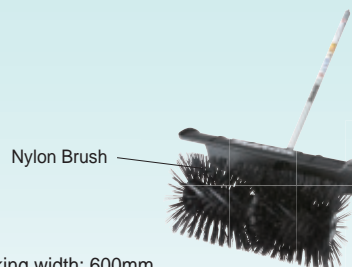

Working width: 600mm
No Load Speed: 230rpm
Outer diameter of Brush: 250mm
Dimension (L x W x H): 1,159 x 600 x 362mm
Net weight: 7.2Kg
Standard Equipments: Torx wrench



**Edger
EE400MP
(Part no: 196752-0)**



Blade dia : 203mm
Dimensions: 878x131x291mm
Net weight : 2.4Kg

Standard Equipments:
Hex wrench 5, Torx Wrench

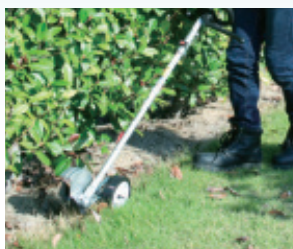

**Blower
UB400MP
(Part no: 191F72-3)**



Maximum wind speed: 59.0m / s
Maximum air volume: 14,4 m³
Weight: 1.7kg



**Shaft extension
attachment
LE400MP
(Part no: 196032-4)**



For Pole saw & For Pole hedge trimmer
Extension Length: 1,080mm
Dimensions: 1,157x80x80mm
Net weight : 1.3kg

CORDLESS

FIXING / FASTENING

DRILLING / IMPACT DRILLING

CONCRETE DRILLING / DEMOLITION

CUTTING [CONCRETE/ MASONRY/ METAL]

MULTI TOOL

GRINDING

SANDING / POLISHING

SAWING

ROUTERING / PLANING

CLEANING

HEAT GUN / LASERS

PNEUMATIC TOOLS



GARDEN TOOLS

GENERATORS

Product Comparison Chart - Chain Saw





Cordless Chain Saw

	MODEL NO	VOLTAGE	GUIDE BAR	CHAIN SPEED	NET WEIGHT	 BL MOTOR	 BRAKE	 SOFT START
MULTI TOOL	DUC405	18V+18V Li-Ion	400mm (16")	0 - 20 m/s	5.5kg	YES	YES	-
	DUC252	18V+18V Li-Ion	250mm (10")	8.3 m/s	4.7kg	-	YES	YES
GRINDING	DUC254	18V Li-Ion	250mm (10")	0 - 24 m/s	3.2kg	YES	YES	YES

Petrol Chain Saw

	MODEL NO	GUIDE BAR	DISPLACEMENT	POWER RATING	FUEL TANK	CHAIN OIL TANK	WEIGHT
SAWING	EA3502S40B	400mm (16")	35 mL	1.7KW / 2.4PS	0.4L	0.29L	4.4kg
	EA4301F45B	450mm (18")	42.4 mL	2.2KW / 3.0PS	0.48L	0.28L	4.8kg
ROUTERING / PLANING	DCS5200	450mm (18")	52 mL	2.7KW / 3.7PS	0.56L	0.28L	4.6kg
	EA6100P	500mm (20")	60.7 mL	3.4KW / 4.6PS	0.8L	0.48L	6.0kg
CLEANING	DCS7301	600mm (24")	72.6 mL	4.2KW / 5.7PS	0.75L	0.42L	6.3kg
	DCS7901	700mm (28")	78.5 mL	4.6KW / 6.3PS	0.75L	0.42L	6.3kg
HEAT GUN / LASERS	DCS9010	740mm (34")	90 mL	4.9KW / 6.7PS	1L	0.4L	8.2kg

Electric Chain Saw

	MODEL NO	GUIDE BAR	POWER	CHAIN SPEED	NET WEIGHT	 BRAKE	 SOFT START
GARDEN TOOLS	5016B	405mm (16")	1,300W	400m/min	5.8Kg	-	-
	UC4041A	400mm (16")	1,800W	870m/min	4.7kg	YES	-
GENERATORS	UC4551A	450mm (18")	2,000W	870m/min	5.7kg	YES	YES

CORDLESS

FIXING / FASTENING

DRILLING / IMPACT DRILLING

CONCRETE DRILLING / DEMOLITION

CUTTING [CONCRETE/ MASONRY/ METAL]

MULTI TOOL

GRINDING

SANDING / POLISHING

SAWING

ROUTERING / PLANING

CLEANING

HEAT GUN / LASERS

PNEUMATIC TOOLS

GARDEN TOOLS

GENERATORS

DUC405 400mm (16") Acc Pg. A207-208

Cordless 18V+18V LXT Chain Saw



Cordless chain saws powered by two 18V Li-ion batteries

- Outer Rotor BL Brushless motor direct-drive system delivers 0-20 m/s
- With Captive nuts for solid bar retention
- Kickback brake and Variable speed trigger switch provide high operability
- Main power switch with auto power-off function for battery saving and avoiding unintentional start up

Specifications:-

Guide Bar Length	400 mm (16")
Cutting Length	370 mm (14-1/2")
Chain Pitch	3/8"
Chain Gauge	1.1 / 1.3 mm (0.043" / 0.050")
Chain Speed	0 - 20 m/s (0 - 1,200 m/min) (0 - 3,940 FPM)
Chain Oil Tank Volume	200 mL
Sound Pressure Level	87.7 dB(A)
Sound Power Level	100.4 dB(A)
Vibration Level	Cutting Wood: 5.3 m/s ²
Dimensions (L x W x H)	800x211x235 mm
Net weight	5.5 kg

Standard Equipment: Saw Chain, Guide Bar, Guide Bar Cover, Oil supply

AVAILABLE VARIANTS		
5.0Ah	3.0Ah	"Z" VARIANT
DUC405 PT2 INCLUDES 2 BATTERIES / 1 TWO PORT CHARGER	-	DUC405 Z TOOL ONLY (DOES NOT INCLUDE BATTERY / CHARGER)

DUC252 250mm (10") Acc Pg. A207-208

Cordless 18V+18V LXT Chain Saw



Cordless chain saws powered by two 18V Li-ion batteries

- Tool-less chain adjustment for convenient operation and maintenance
- Kickback brake & electric brake for maximum productivity and maximum operator safety
- Soft grip top handle is engineered for the user to more easily apply even cutting pressure
- Adjustable automatic chain lubrication with large oil reservoir
- Soft start feature gradually increases speed to eliminate start up shock

Specifications:-

Guide Bar Length	250 mm (10")
Chain Pitch	3/8"
Chain Gauge	1.3 mm
Chain Speed	8.3 m/s
Chain Oil Tank Volume	85 mL
Dimensions (L x W x H)	545x234x198 mm
Net weight	4.7 kg

Standard Equipment: Saw Chain, Guide Bar, Guide Bar Cover, Spike Bumper,

AVAILABLE VARIANTS		
5.0Ah	3.0Ah	"Z" VARIANT
DUC252 PT2 INCLUDES 2 BATTERIES / 1 TWO PORT CHARGER	DUC252 RF2 INCLUDES 2 BATTERIES / 1 CHARGER	DUC252 Z TOOL ONLY (DOES NOT INCLUDE BATTERY / CHARGER)

DUC254 - 250 mm (10") Acc Pg. A207-208

18V LXT - Lithium-ion Cordless Chain saw



High operating efficiency

Outer Rotor BL Motor provides high operating efficiency

High operability

Chain brake and Variable speed trigger switch provide high operability equivalent to engine chain saw.

Specifications:-

Guide Bar Length	250 mm (10")
Chain Pitch / Chain Gauge	3/8" / 1.1 mm (0.043")
	3/8" / 1.3 mm (0.050")
Chain Speed	0 - 24 m/s (0 - 1,440 m/min) (0 - 4,720 FPM)
Chain Oil Tank Volume	140 mL
Sound Pressure Level	92.2 dB(A)
Sound Power Level	103.2 dB(A)
Vibration Level	Cutting Wood: 3.1 m/s ²
Dimensions (L x W x H)	w/o Guide Bar : 258x184x191 mm
Net weight	3.2 kg

Standard Equipment: Saw Chain, Guide Bar, Guide Bar Cover, Wrench, Accessory Bag

AVAILABLE VARIANTS		
5.0Ah	3.0Ah	"Z" VARIANT
-	-	DUC254 Z TOOL ONLY (DOES NOT INCLUDE BATTERY / CHARGER OR CARRY CASE)



Max. chain speed
24 m/s
Saw chain: 90px or 91px

Work amount*
160 cut
BL1850B

*Work amount (approx): cuts (Cut 50mm cedar timber with 91PX saw chain under the normal condition.)

- CORDLESS
- FIXING / FASTENING
- DRILLING / IMPACT DRILLING
- CONCRETE DRILLING / DEMOLITION
- CUTTING [CONCRETE/ MASONRY/ METAL]
- MULTI TOOL
- GRINDING
- SANDING / POLISHING
- SAWING
- ROUTERING / PLANING
- CLEANING
- HEAT GUN / LASERS
- PNEUMATIC TOOLS
- GARDEN TOOLS
- GENERATORS

CORDLESS

FIXING / FASTENING

DRILLING / IMPACT DRILLING

CONCRETE DRILLING / DEMOLITION

CUTTING [CONCRETE/ MASONRY/ METAL]

MULTI TOOL

GRINDING

SANDING / POLISHING

SAWING

ROUTERING / PLANING

CLEANING

HEAT GUN / LASERS

PNEUMATIC TOOLS

GARDEN TOOLS

GENERATORS

Handy chain saw for Prune trees or cut firewood

EA3502S40B 400mm (16")



EA3502S40B 400mm (16")

Acc Pg. A207-208

Petrol Chain Saw

Entry class



Entry class chain saw for home and garden with more power.

- Rapid start and Touch & Stop switch for easy operating.
- Environment-friendly 2-stroke engine.
- Compact and lightweight body for better handling.
- Metal spike bumper firmly grips workpiece to provide more control, making cutting easier

Specifications:-



Standard guide bar	400mm (6")
Saw chain	Pitch : 3/8" / Gauge : 1.1mm / 1.3mm
Displacement	35.0mL
Engine power	1.7kW / 2.4PS
Fuel tank	0.4 L
Chain oil tank	0.29 L
Vibration level Front handle	4.9m/s ²
Vibration level Rear handle	5.0m/s ²
Dimensions (L x W x H)	415x247x273mm
Power head weight	4.4kg

Standard Equipment: Saw Chain, Guide bar, Guide Bar Cover, Socket Wrench, Screwdriver

EA4301F45B 450mm (18")

Acc Pg. A207-208

Petrol Chain Saw

Semi-professional



High Power & Higher Maneuverability semi-professional chain saw

- Rapid start, On-off choke combination switch and Primer pump for providing higher maneuverability
- A light touch on the switch stops the engine, and the switch returns automatically to the start position, eliminating irksome flooding of the carburetor
- Metal spike bumper firmly grips workpiece to provide more control, making cutting easier

Specifications:-



Guide bar length	450mm (18")
Saw chain	Pitch : 0.325" / Gauge: 1.3 mm
Displacement	42.4 mL
Engine power	2.2 kW / 3.0 PS
Fuel Tank Capacity	0.48 L
Chain Oil Tank Volume	0.28 L
Sound Pressure Level	100.8 dB(A)
Sound Power Level	110 dB(A)
Vibration Level Front Grip	3.6 m/s ²
Vibration Level Rear Grip	3.2 m/s ²
Dimensions (L x W x H)	416x248x279 mm
Power head weight	4.8 kg

Standard Equipment: Saw Chain, Guide Bar, Guide Bar Cover, Socket Wrench, Hex Wrench, Screwdriver

DCS5200 450mm (18")

Acc Pg. A207-208

Petrol Chain Saw

Semi-professional



Extra-rugged engine for max. performance in extra-tough jobs.

- Chill cast cylinder.
- Double air filtration system.
- Inertia chain brake.

Specifications:-



Standard guide bar	450mm (18")
Chain Blade	Pitch : 3/8" / Gauge : 0.058"
Displacement	52mL
Power rating	2.7kW / 3.7PS
Fuel tank	0.56L
Chain oil tank	0.28L
Power head weight	4.6kg (10.1lbs)

Standard Equipment: Chain Blade, Guide Bar Cover, Wrenches.

EA6100P 500mm (20") Acc Pg. A207-208

Petrol Chain Saw

Professional



3.4 kW (4.6 HP) professional chain saw

- Magnesium housing for improved durability and less weight
- Easy Start spring-assisted starter for quick starting with less force
- Heavy-duty cyclonic-cartridge air filter system for improved durability
- Touch & Stop single lever control shuts off engine with just a touch
- Stratified scavenging system complying with many exhaust emission regulations
- Perfect saw for felling and debranching in one machine
- Low-vibration system with damper springs to absorb vibration from engine

Specifications:-

Saw chain	Pitch : 0.325 or 3/8" Gauge: 1.5 mm (0.058")
Displacement	60.7 mL
Engine power	3.4 kW / 4.6 PS
Fuel Tank Capacity	0.8 L
Chain Oil Tank Volume	0.48 L
Sound Pressure Level	105 dB(A)
Sound Power Level	117 dB(A)
Vibration Level Front Grip	5.0 m/s ²
Vibration Level Rear Grip	4.0 m/s ²
Dimensions (L x W x H)	435x243x312 mm
Power head weight	6.0 kg

Standard Equipment: Chain Blade, Guide Bar Cover, Wrenches.

DCS7301 600mm (24") Acc Pg. A207-208

Petrol Chain Saw

Professional



Professional chain saw with ergonomic designed body.

- Improved air filtration through the Airmaster® air filter system.
- Simpler starting through semi automatic half-throttle stop.
- Vibration damping with tough, long-life steel springs.
- Rapid start.

Specifications:-

Standard guide bar	600mm (24")
Chain Blade	Pitch : 3/8" Gauge : 0.058"
Displacement	72.6 c.c.
Power rating	4.2KW / 5.7PS
Fuel tank	0.75L
Chain oil tank	0.42L
Power head weight	6.3kg (13.89lbs)

Standard Equipment: Chain Blade, Guide Bar Cover, Wrenches.

DCS7901 700mm (28") Acc Pg. A207-208

Petrol Chain Saw

Professional



Professional chain saw with ergonomic designed body.

- Improved air filtration through the Airmaster air filter system.
- Simpler starting through semi automatic half-throttle stop.
- Vibration damping with tough, long-life steel springs.
- Rapid start.

Specifications:-



Standard guide bar	700mm (28")
Chain Blade	Pitch : 3/8" Gauge : 0.058"
Displacement	78.5 c.c.
Power rating	4.6KW / 6.3PS
Fuel tank	0.75L
Chain oil tank	0.42L
Power head weight	6.3kg (13.89lbs)

Standard Equipment: Chain Blade, Guide Bar Cover, Wrenches.

DCS9010 740mm (29") Acc Pg. A207-208

Petrol Chain Saw

Professional

Heavy timber saw for the hardest working professionals.

- Armed with newly designed carburetor, ignition assembly, muffler and 7-tooth sprocket.
- Max. engine speed 13,500rpm.

Specifications:-

Standard guide bar	740mm (29")
Chain blade	Pitch: 3/8" Gauge: 0.058"
Displacement	90cc
Power rating	4.9kW/6.7PS
Fuel tank	1L
Chain oil tank	0.4L
Power head weight	8.2kg (18.1 lbs)

Standard Equipment: Chain Blade, Guide Bar Cover, Wrench, Screwdriver.

- CORDLESS
- FIXING / FASTENING
- DRILLING / IMPACT DRILLING
- CONCRETE DRILLING / DEMOLITION
- CUTTING [CONCRETE/ MASONRY/ METAL]
- MULTI TOOL
- GRINDING
- SANDING / POLISHING
- SAWING
- ROUTERING / PLANING
- CLEANING
- HEAT GUN / LASERS
- PNEUMATIC TOOLS
- GARDEN TOOLS
- GENERATORS

CORDLESS

FIXING / FASTENING

DRILLING / IMPACT DRILLING

CONCRETE DRILLING / DEMOLITION

CUTTING [CONCRETE/ MASONRY/ METAL]

MULTI TOOL

GRINDING

SANDING / POLISHING

SAWING

ROUTERING / PLANING

CLEANING

HEAT GUN / LASERS

PNEUMATIC TOOLS

GARDEN TOOLS

GENERATORS

EY2650H25H 25.4mL 4-stroke

Acc Pg. A207-208

Telescopic Petrol Pole Saw

Environment-friendly and cost-saving 25.4mL 4-stroke engine with multi-position lubrication system

Multi-position lubrication system enables the engine to be inclined to any angle for continuous operation without emission of the white smoke and the smell of burning engine oil.



Lightweight design

The Lightweight pole saw head reduces operator fatigue.

Rubberized soft grip

Guide bar length: 255mm (10")
Part No. 165695-7

2,720mm~3,920mm

Saw chain: 91VXL-39E
Pitch: 3/8"
Gauge: 1.3mm (0.050")
Part No. 196142-7

Guide bar cover
Part No. 452093-7

Adjustable oil pump

Chain oil tank capacity : 120mL



The pole length can be adjusted easily with a screw.



Specifications:-





Displacement	25.4mL
Engine power	0.77kW / 1.1PS
Fuel tank	0.6L
Guide bar length	255mm (10")
Chain blade	Gauge: 1.3mm / Pitch: 3/8"
Dimensions (L x W x H)	2,720 x 223 x 240mm
Net weight	7.2kg

Standard Equipment: Chain blade with guide bar and guide bar cover, 80ml 4T engine oil, Shoulder harness, Safety goggle, Tool set, Accessory bag

UC4551A 450mm (18") Acc Pg. A207-208 **153** 

Electric Chain Saw

New adjustment lever for easier Tool-less tension adjustment of saw chain.

- Improved oil pump keeps the delivery of chainoil constant regardless of temperature and the oil viscosity.
- Large view window of oil tank allows operator to easily check oil level.
- Large separate-type metal spike bumper.
- Longitudinal motor provides better maneuverability.
- Electronic control: Soft start and current limiter

Specifications:- 

Continuous rating input	2,000W
Chain speed per minute	870m/min
Guide bar length	450mm (18")
Chain blade	Pitch : 3/8" Gauge : 0.050"
Sound pressure level	90.8dB(A)
Sound power level	101.8dB(A)
Vibration level	5.2m/s ²
Dimensions (L x W x H)	505x200x220mm (19-7/8"x7-7/8"x8-5/8")
Net weight	5.7kg (12.5lbs)
Power supply cord	0.3m (0.98ft)

Standard Equipment: Chain blade, Guide bar cover, Hook complete, Wrench

UC4041A 400mm (16") Acc Pg. A207-208 **153** 

Electric Chain Saw



New adjustment lever for easier Tool-less tension adjustment of saw chain.

- Improved oil pump keeps the delivery of chainoil constant regardless of temperature and the oil viscosity.
- Large view window of oil tank allows operator to easily check oil level.
- Large separate-type metal spike bumper.
- Flat motor housing end.
- Easy-to-grip Front loop handle.

Specifications:- 

Continuous rating Input	1,800W
Chain speed per minute	870m/min (2,900ft/min)
Guide bar length	400mm (16")
Chain blade	Pitch : 3/8" Gauge : 1.1mm (.043") / or 1.3mm (.050")
Sound pressure level	90.3dB(A)
Sound power level	101.3dB(A)
Vibration level	4.7m/s ²
Dimensions (L x W x H)	455x245x200mm (17-7/8"x9-5/8"x7-7/8")
Net weight	4.7kg (10.5lbs)

Standard Equipment: Chain blade, Guide bar cover, Hook complete, Wrench



New adjustment lever for easier Tool-less tension adjustment of saw chain

Extendable to allow for easier saw chain tightening and higher tightening torque. Can be quickly retracted at any angle.



Improved oil pump

Keeps the delivery of chain oil constant regardless of temperature and the oil viscosity.



UC4041A 400mm **UC4551A** 450mm

DUP362

18V+18V LXT Lithium-Ion Cordless Pruning Shears



18V X2 (36V) LXT Li-Ion Battery Powered Pruning Shears

- Higher torque for increased cutting performance (DUP362)
- 18V solution for corded power demands
- Smooth cutting similar to that of a hand pruner
- Extra sharp, made-in-Japan forged blade

Specifications:-

Capacity	Max cutting : 33 mm Max blade opening : 54 mm
Cutting Torque	250 N
Sound Pressure Level	70 dB(A) or less
Vibration Level	2.5 m/s ² or less
Dimensions (L x W x H)	305x43x106 mm
Net weight	0.8 kg

Standard Equipment: Wrench set, Holster, Harness, Arm Band

AVAILABLE VARIANTS		
5.0Ah	3.0Ah	"Z" VARIANT
-	-	DUP362 Z TOOL ONLY (DOES NOT INCLUDE BATTERY / CHARGER)

- CORDLESS
- FIXING / FASTENING
- DRILLING / IMPACT DRILLING
- CONCRETE DRILLING / DEMOLITION
- CUTTING [CONCRETE/ MASONRY/ METAL]
- MULTI TOOL
- GRINDING
- SANDING / POLISHING
- SAWING
- ROUTERING / PLANING
- CLEANING
- HEAT GUN / LASERS
- PNEUMATIC TOOLS
- GARDEN TOOLS
- GENERATORS

- CORDLESS
- FIXING / FASTENING
- DRILLING / IMPACT DRILLING
- CONCRETE DRILLING / DEMOLITION
- CUTTING [CONCRETE/ MASONRY/ METAL]
- MULTI TOOL
- GRINDING
- SANDING / POLISHING
- SAWING
- ROUTERING / PLANING
- CLEANING
- HEAT GUN / LASERS
- PNEUMATIC TOOLS
- GARDEN TOOLS
- GENERATORS

DUH551 550mm (21-5/8") Acc Pg. A209 **442**

18V+18V LXT Lithium-Ion Cordless Hedge Trimmer



High maneuverability and environment friendly.

5 position adjustable handle

Locks at 45° and 90° left and right and 0°, for easy and fast trimming in any angle.

Well balanced tool design by positioning the batteries at rear end of the tool.



Runtime*
75-125min
BL1850B x2

*No load continuous run time (approx) : min

Specifications:-



Blade length	550mm (21-5/8")
Strokes per minute(spm)	2,000-3,600
Sound pressure level	81.5dB(A)
Sound power level	91dB(A)
Dimensions (L x W x H)	1,065 x 225 x 200mm
Max. output	0.32kW
Net weight	5.1kg (11.3lbs)

Standard Equipment: Blade cover.

AVAILABLE VARIANTS

5.0Ah	3.0Ah	"Z" VARIANT
		DUH551 Z TOOL ONLY (DOES NOT INCLUDE BATTERY / CHARGER)

DUN500W - 500 mm Acc Pg. A209

18V LXT - Lithium-ion Cordless Pole Hedge Trimmer



(Curved blades)

Cutting blade angle: °115 foldable for easy transport and storage:

- New triple-edged cutting teeth are designed to easily catch and firmly hold twigs, also featuring excellent sharpness
- Curved blades reduce friction resistance to suppress energy loss.
- Reverse rotation system frees the blade when it is jammed by thick branches

Specifications:-



Blade Length	500 mm (19-3/4")
Max Cutting Capacity	23.5 mm (15/16")
Sound Pressure Level	81.5 dB(A)
Sound Power Level	92.5 dB (A)
Vibration Level: Left hand (Front grip / Handle)	4.7 m/s ²
Vibration Level: Right hand (Rear grip)	2.5 m/s ² or less
Strokes Per Minute (SPM)	High / Med / Low: 4,400 / 3,600 / 2,000
Overall length	2,115 mm
Net weight	4.5 kg

Standard Equipment: Blade Cover, Harness

AVAILABLE VARIANTS

6.0Ah	3.0Ah	"Z" VARIANT
DUN500W RG2 2PCS OF BATTERIES / 1PC TWO PORT CHARGER (DOES NOT INCLUDE CARRY CASE)	-	DUN500W Z TOOL ONLY (DOES NOT INCLUDE BATTERY / CHARGER OR CARRY CASE)

DUH751 - 750 mm Acc Pg. A209

18V LXT - Lithium-ion Cordless Hedge Trimmer



double side blade



18V LXT BL Cordless Hedge Trimmer with double side blade

- Optimum blade shape for smooth cutting
- Reliable cutting performance like engine/AC hedge trimmers
- The no load continuous run time on a full battery charge is the same or longer than that on a full tank of petrol
- 5 position rotating rear handle

Specifications:-



Blade Length	750 mm
Max Cutting Capacity	23.5 mm
Sound Pressure Level	84 dB(A)
Sound power level	97 dB(A)
Vibration Level	2.5 m/s ²
Strokes Per Minute (SPM)	High / Med / Low: 0 - 4,400 / 0 - 3,600 / 0 - 2,000
Dimensions (L x W x H)	1,261x225x192 mm
Net weight	4.5 kg

Standard Equipment: Blade Cover, Safety Goggles

AVAILABLE VARIANTS

5.0Ah	3.0Ah	"Z" VARIANT
DUH751 PTE 2PCS OF BATTERIES / 1PC TWO PORT CHARGER (DOES NOT INCLUDE CARRY CASE)	-	DUH751 Z TOOL ONLY (DOES NOT INCLUDE BATTERY / CHARGER OR CARRY CASE)

DUH754S - 750 mm Acc Pg. A209 - 210

18V LXT - Lithium-ion Cordless Hedge Trimmer



single side blade



18V LXT BL Cordless Hedge Trimmer with single side blade

- Optimum blade shape for smooth cutting
- Reliable cutting performance like engine/AC hedge trimmers
- The no load continuous run time on a full battery charge is the same or longer than that on a full tank of petrol

Specifications:-



Blade Length	750 mm
Max Cutting Capacity	23.5 mm
Sound Pressure Level	80.6 dB(A)
Sound power level	91.6 dB (A)
Vibration Level	2.5 m/s ² or less
Strokes Per Minute (SPM)	High / Med / Low: 0 - 4,400 / 0 - 3,600 / 0 - 2,000
Dimensions (L x W x H)	1,198x280x147 mm
Net weight	4.1 kg

Standard Equipment: Blade Cover, Safety Goggles

AVAILABLE VARIANTS

5.0Ah	3.0Ah	"Z" VARIANT
-	-	DUH754 Z TOOL ONLY (DOES NOT INCLUDE BATTERY / CHARGER OR CARRY CASE)

UH5261 520mm (20-1/2") Acc Pg. A209 **419** 

Electric Hedge Trimmer



Ergonomically designed grips provides more control and comfort while minimizing hand fatigue.

- Stain-free shear blade surface obtained by non-electrolyzed nickel plating features high anti-abrasion surface for a long lasting coating.
- Protection of extension cord from breakage.

Specifications:- 

Continuous rating Input	400W
Blade length	520mm (20-1/2")
Strokes per minute (spm)	3,200
Dimensions (L x W x H)	921 x 194 x 194mm (36-1/4" x 7-5/8" x 7-5/8")
Net weight	3.0kg (6.5lbs)
Power supply cord	0.3m (0.98ft)

Standard Equipment: Blade Cover, Hook Complete, Cord holder Complete Set.

UH7580 750mm (29-1/2") **419** 

Electric Hedge Trimmer

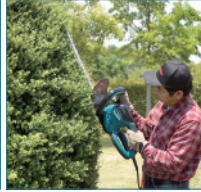

High power and superior operation.

- Ergonomically designed rubberized soft grips provide more control and comfort.
- Three switches are installed in handle, front grip and sub grip.
- Tool starts only when any two pair of the three switches are pressed at the same time.
- Guard is provided at the tip of blades to prevent kick-back.
- Blades are coated to improve durability.

Specifications:- 

Continuous rating Input	670W
Blade length	750mm (29-1/2")
Strokes per minute (spm)	3,000
Dimensions (L x W x H)	1,157 x 223 x 206mm (45-1/2" x 8-3/4" x 8-1/8")
Net weight	4.6kg (10.1lbs)
Power supply cord	0.3m (0.98ft)

Standard Equipment: Blade Cover, Hook Complete, Belt Hook.

UH6570 650mm (25-1/2") Acc Pg. A209 **419** 

Electric Hedge Trimmer



Comfortable operation by ergonomically designed rubberized soft grip.

- Three switches are installed in handle, front grip and sub grip.
- Tool starts only when any two pair of the three switches are pressed at the same time.
- Guard is provided at the tip of blades to prevent kick-back.
- Blades are coated to improve durability.

Specifications:- 

Continuous rating Input	550W
Blade length	650mm (25-1/2")
Strokes per minute (spm)	3,200
Dimensions (L x W x H)	1,042 x 223 x 206mm (41" x 8-3/4" x 8-1/8")
Net weight	3.7kg (8.1lbs)
Power supply cord	0.3m (0.98ft)

Standard Equipment: Blade Cover, Hook Complete, Belt Hook.

EN4950H 490mm(19-1/4") Acc Pg. A209

Petrol Pole Hedge Trimmer



4-stroke engine with the multi-position engine lubrication system

- Compact design for greater versatility in the garden as well as in commercial applications
- Angle adjustable hedge trimmer head
- 45° tilt-up to 90° tilt-down from the horizontal position
- Blade does not move while hedge trimmer head is 180° in the folded position
- 180° foldable for easy transport and storage
- 13 angle settings (11.25° each):

Specifications:- 

Blade length	490mm(19-1/4")
Displacement	25.4ml
Engine power	0.77kW / 1.1PS
Fuel tank	0.6L
Strokes per minute (spm)	4,200
Sound pressure level	90dB(A)
Sound power level	102.2dB(A)
Vibration level Front handle	6.3m/s ²
Vibration level Rear handle	8.9m/s ²
Dimensions (L x W x H)	2,550x242x241mm (100-1/2" x 9-1/2" x 9-1/2")
Net weight	6.9kg (15lbs)

Standard Equipment: Blade cover, Box driver, Accessory bag, Oil set, Shoulder strap, Safety goggles, End cover set, Hex wrench

CORDLESS

FIXING / FASTENING

DRILLING / IMPACT DRILLING

CONCRETE DRILLING / DEMOLITION

CUTTING [CONCRETE/ MASONRY/ METAL]

MULTI TOOL

GRINDING

SANDING / POLISHING

SAWING

ROUTERING / PLANING

CLEANING

HEAT GUN / LASERS

PNEUMATIC TOOLS

GARDEN TOOLS

GENERATORS

Petrol Hedge trimmer

Environment-friendly -2stroke engine



Longer lubrication cycle obtained by circulating grease in gear housing

Approx. **50**

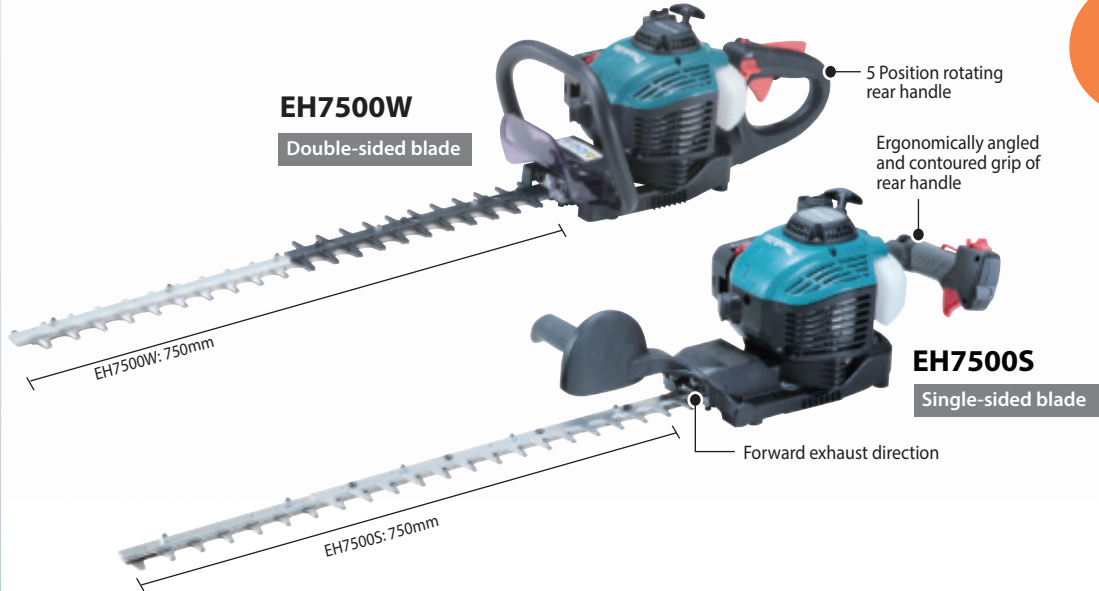

Anti-vibration System

Equipped with floating structure of engine section and handle section for anti-vibration; four damper springs absorb vibration from engine to integrated front and rear handles.

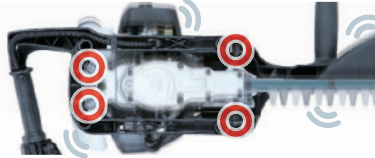

Blade Teeth with 3 Sharpened Edges

Stain-free shear blade surface of glittering silver obtained by non-electrolyzed nickel plating that features high anti-abrasion surface for long lasting coating



Sap on the blade (after 10 hour trimming of Boxwood)



5 Position Rotating Rear Handle (EH6000W, EH7500W)

can be locked at 0 degree and 90 /45 degrees left and right for vertical or angled trimming.



EH7500W 750mm (29-1/2")	Acc Pg. A209	EH7500S 750mm (29-1/2")	Acc Pg. A209-210
--------------------------------	--------------	--------------------------------	------------------

Petrol Hedge Trimmer

Specifications:-

Blade length	750mm (29-1/2")
Displacement	22.2mL
Power rating	0.68kW / 1.0PS
Fuel mixture	50 : 1
Fuel tank	0.4L
Dimensions (L x W x H)	1,259mm x 262mm x 216mm (49-1/2"x10-3/8"x8-1/2")
Net weight	5.2kg (11.4lbs)

Standard Equipment: Blade Cover, Tool Set.

Petrol Hedge Trimmer

Specifications:-

Blade length	750mm (29-1/2")
Displacement	22.2mL
Power rating	0.68kW (1.0PS)
Fuel mixture	50 : 1
Fuel tank	0.4L
Dimensions (L x W x H)	1,150mm x 323mm x 212mm (45-1/4"x12-3/4"x8-3/8")
Net weight	4.7kg(10.4lbs)

Standard Equipment: Blade Cover, Tool Set.



- CORDLESS
- FIXING / FASTENING
- DRILLING / IMPACT DRILLING
- CONCRETE DRILLING / DEMOLITION
- CUTTING (CONCRETE/ MASONRY/ METAL)
- MULTI TOOL
- GRINDING
- SANDING / POLISHING
- SAWING
- ROUTERING / PLANING
- CLEANING
- HEAT GUN / LASERS
- PNEUMATIC TOOLS
- GARDEN TOOLS
- GENERATORS

String Trimmers / Brushcutters



CORDLESS

FIXING / FASTENING

DRILLING / IMPACT DRILLING

CONCRETE DRILLING / DEMOLITION

CUTTING [CONCRETE/ MASONRY/ METAL]

MULTI TOOL

GRINDING

SANDING / POLISHING

SAWING

ROUTERING / PLANING

CLEANING

HEAT GUN / LASERS

PNEUMATIC TOOLS

GARDEN TOOLS

GENERATORS

UR101C / UR201C

Acc Pg. A210-212

18V+18V LXT Lithium-Ion Cordless Battery Powered Grass Trimmer



ADAPT TO METAL BLADE
 - Used with PDC01 power source kit
 - Excellent tool in continuous work
 - High power 1 kW equivalent to petrol tool
 - Electronic -3Speed control

NYLON CUTTING HEAD
Reverse switch
 for clearing entangled weeds and grass from cutting head

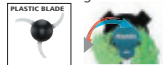

BL Motor
 Rear end mounted brushless motor makes the tool balance similar to engine grass trimmers



Runtime*
 Nylon cutting head (430mm)

Low	Mid	Hi
58	40	26
min		
PDC01 (BL1860B x4)		

*No load continuous run time (approx)

Specifications:-

Cutting Width	
No Load Speed (RPM)	
Spindle Size	
Vibration Level	
Dimensions (L x W x H)	
Net weight	

Standard Equipment: Safety Goggles, Hex Wrench

AVAILABLE VARIANTS		
5.0Ah	3.0Ah	"Z" VARIANT
		UR101C Z TOOL ONLY (DOES NOT INCLUDE BATTERY / CHARGER)

AVAILABLE VARIANTS		
5.0Ah	3.0Ah	"Z" VARIANT
		UR201C Z TOOL ONLY (DOES NOT INCLUDE BATTERY / CHARGER)

- CORDLESS
- FIXING / FASTENING
- DRILLING / IMPACT DRILLING
- CONCRETE DRILLING / DEMOLITION
- CUTTING [CONCRETE/ MASONRY/ METAL]
- MULTI TOOL
- GRINDING
- SANDING / POLISHING
- SAWING
- ROUTERING / PLANING
- CLEANING
- HEAT GUN / LASERS
- PNEUMATIC TOOLS
- GARDEN TOOLS
- GENERATORS

DUR369A

Acc Pg. A210-212

18V+18V LXT Lithium-Ion Cordless Grass Trimmer



Offset handle
Enabling user to work with less fatigue even in long continuous operation and allowing for a wider swing.

BL Motor
Rear end mounted brushless motor makes the tool balance similar to engine grass trimmers

Reverse switch
for clearing entangled weeds and grass from cutting head

Specifications:-

Cutting Width	Metal Blade: 255 mm Nylon Cutting Head: 430 mm Plastic Blade: 305 mm
No Load Speed (RPM)	Metal Blade (3 / 2 / 1): 0 - 7,000 / 0 - 5,500 / 0 - 4,600 Nylon Cutting Head (3 / 2 / 1): 0 - 5,500 / 0 - 5,000 / 0 - 4,600 Plastic Blade (305 mm) (3 / 2 / 1): 0 - 7,000 / 0 - 5,500 / 0 - 4,600 Plastic Blade (255 mm) (3 / 2 / 1): 0 - 5,500 / 0 - 5,000 / 0 - 4,600
Spindle Size	M10 x 1.25 LH
Vibration Level	Left / Right: 2.5 / 2.5 m/s ² or less
Dimensions (L x W x H)	1,846x628x530 mm
Net weight	6.3 kg

Standard Equipment: Safety Goggles, Hex Wrench

AVAILABLE VARIANTS

5.0Ah	3.0Ah	"Z" VARIANT
-	-	DUR369A Z TOOL ONLY (DOES NOT INCLUDE BATTERY / CHARGER)

DUR364L

Acc Pg. A210-212

18V+18V LXT Lithium-Ion Cordless Grass Trimmer



Loop handle

BL Motor
Outer Rotor BL Motor provides high operating efficiency

Direct drive system
for more power, more speed and longer run time

Reverse switch
for clearing entangled weeds and grass from cutting head

Specifications:-

Cutting Width	Trimmer Head: 350 mm
No Load Speed (RPM)	High / Low: 6,500 / 5,000
Spindle Size	M8 x 1.25 RH
Vibration Level	Front / Rear: 2.5 / 2.5 m/s ² or less
Dimensions (L x W x H)	1,754x310x229 mm
Net weight	4.4 kg

Standard Equipment: Safety Goggles, Hex Wrench

AVAILABLE VARIANTS

5.0Ah	3.0Ah	"Z" VARIANT
-	-	DUR364L Z TOOL ONLY (DOES NOT INCLUDE BATTERY / CHARGER)

DUR369N

Acc Pg. A210-212

18V+18V LXT Lithium-Ion Cordless Grass Trimmer



Loop handle

BL Motor
Rear end mounted brushless motor makes the tool balance similar to engine grass trimmers

Reverse switch
for clearing entangled weeds and grass from cutting head

Specifications:-

Cutting Width	Nylon Cutting Head: 430 mm Plastic Blade: 305 mm
No Load Speed (RPM)	Nylon Cutting Head (3 / 2 / 1): 0 - 5,000 / 0 - 4,600 / 0 - 4,000
Spindle Size	M10 x 1.25 LH
Vibration Level	Left / Right: 2.5 / 2.5 m/s ² or less
Dimensions (L x W x H)	1,834x226x301 mm
Net weight	6.1 kg

Standard Equipment: Safety Goggles, Hex Wrench

AVAILABLE VARIANTS

5.0Ah	3.0Ah	"Z" VARIANT
-	-	DUR369N Z TOOL ONLY (DOES NOT INCLUDE BATTERY / CHARGER)



DUR190 Acc Pg. A210-212

18V LXT - Lithium-ion Cordless Grass Trimmer



18V LXT BL ADT Cordless Grass Trimmer, Lightweight design with excellent tool balance for easy handling during operation

- Multifunctional control panel for power on-off / variable speed control / reversing blade rotation
- Nylon cutting head rotating clockwise prevents grass clippings from flying towards user's side
- Anti-weed winding guard - The guard integed with receive washer prevents weed winding.
- Toolless shaft lock for easy blade change

Specifications:-

Cutting Width	Trimmer Head: 300 mm Metal Blade: 230 mm Plastic Blade: 255 mm
Max Run Time (min)	66 / 89 / 210 (with nylon cutting head) (BL1860B)
No Load Speed (RPM)	3,500 - 6,000
Spindle Size	M10 x 1.25 LH
Dimensions (L x W x H)	1,836x610x473 mm
Net weight	3.4 kg

Standard Equipment: Safety Goggles, Hex Wrench

AVAILABLE VARIANTS		
5.0Ah	3.0Ah	"Z" VARIANT
DUR190 RT INCLUDES 2 BATTERIES / 1 CHARGER	-	DUR190 Z TOOL ONLY (DOES NOT INCLUDE BATTERY / CHARGER)

DUR189 Acc Pg. A210-212

Cordless 18V LXT Grass Trimmer



18V LXT BL ADT Cordless Grass Trimmer, Short Telescopic Pipe, Loop Handle (3 Speed Control)

- Comfortable short telescopic pipe provides easy handling in tight spaces
- Multifunctional control panel for power on-off / variable speed control / reversing blade rotation
- Nylon cutting head rotating clockwise prevents grass clippings from flying towards user's side

Specifications:-

Cutting Width	Trimmer Head: 300 mm
No Load Speed (RPM)	High / Medium / Low / ADT Mode: 6,000 / 5,000 / 4,000 / 4,000 - 6,000
Spindle Size	M8 x 1.25 RH
Vibration Level	Front / Rear: 2.1 / 1.6 or less
Dimensions (L x W x H)	1,518-1,618x258x369 mm
Max Run Time (min)	with BL1850B: 139
Net weight	3.4 kg

Standard Equipment: Safety Goggles, Hex Wrench

AVAILABLE VARIANTS		
5.0Ah	3.0Ah	"Z" VARIANT
-	DUR189 RFE INCLUDES 2 BATTERIES / 1 CHARGER	DUR189 Z TOOL ONLY (DOES NOT INCLUDE BATTERY / CHARGER)

UR100D Acc Pg. A210-212

Cordless CXT Li-Ion Grass Trimmer



12V max CXT Li-Ion Cordless Grass Trimmer

- Well balanced design with fully adjustable features to suit any operator
- Delivers 10,000 / 9,000 RPM for faster cutting
- Compact size is ideal for trimming and precise edging

Specifications:-

Cutting Width	Nylon Cutting Head: 260 mm
No Load Speed (RPM)	Nylon Cutting Head: 9,000
Spindle Size	M8 x 1.25 RH
Vibration Level	-
Dimensions (L x W x H)	835 - 1,185x267x210 - 315 mm
Max Run Time (min)	With BL1041B: 38
Net weight	2.3 kg

Standard Equipment: Safety Goggles, Hex Wrench

AVAILABLE VARIANTS		
4.0Ah	2.0Ah	"Z" VARIANT
UR100D WME INCLUDES 2 BATTERIES / 1 CHARGER	-	UR100D Z TOOL ONLY (DOES NOT INCLUDE BATTERY / CHARGER)

EM2500U 24.5mL - 2 Stroke Acc Pg. A210-212

Petrol String Trimmer / Brush Cutter



Ergonomic handle bar of asymmetrical design.

- Enables user to work in a comfortable posture with less fatigue through out operation.
- Provides easy handling.

Specifications:-

Displacement	24.5mL
Engine power	0.73kW / 1.0PS
Fuel tank	0.5L
Fuel mixture	50:1
Spindle Size	M8 x 1.25LH
Dimensions (L x W x H)	1,770 x 620 x 410 mm (69-3/4" x 24-3/8" x 16-1/8")
Net weight	4.5kg (9.9lbs)

Standard Equipment: String trimmer head (A-89143), Socket wrench, Hex wrench,

- CORDLESS
- FIXING / FASTENING
- DRILLING / IMPACT DRILLING
- CONCRETE DRILLING / DEMOLITION
- CUTTING [CONCRETE/ MASONRY/ METAL]
- MULTI TOOL
- GRINDING
- SANDING / POLISHING
- SAWING
- ROUTERING / PLANING
- CLEANING
- HEAT GUN / LASERS
- PNEUMATIC TOOLS
- GARDEN TOOLS
- GENERATORS

- CORDLESS
- FIXING / FASTENING
- DRILLING / IMPACT DRILLING
- CONCRETE DRILLING / DEMOLITION
- CUTTING [CONCRETE/ MASONRY / METAL]
- MULTI TOOL
- GRINDING
- SANDING / POLISHING
- SAWING
- ROUTERING / PLANING
- CLEANING
- HEAT GUN / LASERS
- PNEUMATIC TOOLS
- GARDEN TOOLS
- GENERATORS

RST250 24.5mL Acc Pg. A210-212

Petrol String Trimmer



Light weight and handy string trimmer.

- Automatic / bump line feed trimmer head.
- Low noise and vibration.
- Solid state ignition for easy starting.
- Carburetor : Diaphragm-type, Ignition system : Solid state ignition.

Specifications:-

Displacement	24.5 mL
Power rating	0.95KW / 1.3PS
Fuel tank	0.5L
Fuel mixture	25 : 1
Dimensions	1,490mm x 300mm x 485mm
Net weight	4.2kg (9.2lbs)

Standard Equipment: Tool kit.

EM2650UH 25.4mL-4stroke Acc Pg. A210-212

Petrol Brush Cutter



Maneuverable pole and handle.

- Ergonomically designed rubberized soft grip provides more control and comfort.
- Universal guard for both saw blade and Nylon cutter.
- Light weight.
- No choke at starting engine.
- Good oil maintenance feature.

Specifications:-

Displacement	25.4mL
Engine power	0.77kW / 1.1PS
Fuel tank	0.6L
Spindle size	M10 X 1.25LH
Dimensions (L x W x H)	1,765 x 620 x 474mm (69-1/2" x 24-3/8" x 18-2/3")
Net weight	5.5kg (12.14lbs)

Standard Equipment: Socket Wrench, Hex Wrenches

RBC411U 40.2mL Acc Pg. A210-212

Petrol Brush Cutter

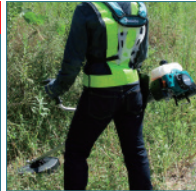

Makita robust brush cutter ideal for professional brush-cutting.

- Powerful and reliable 40.2mL engine designed for professionals and minimizing your maintenance job.
- Perfect balance and an excellent weight-to-power ratio.
- The rigid drive shaft, durable gear head & aluminum post ensure top-performance.
- Convenient swivel-post for any cutting positions.
- Carburetor: Float-type, Ignition system: Solid state ignition.
- Ergonomic soft grip

Specifications:-

Displacement	40.2 mL
Engine power	1.40 kW / 2.0 PS
Fuel Tank Capacity	1.1 L
Spindle Size	M10 x 1.25LH
Dimensions (L x W x H)	1,710x670x430 mm
Net weight	7.3 kg

Standard Equipment: Socket Wrench, Hex Wrenches

UR3000 Acc Pg. A210-212

Electric String Trimmer



Light weight AC string trimmers for do-it-yourselfers.

- Rigid aluminum pipe shaft.
- Easy-to-change spool assembly.
- Can be used as an edger.

Specifications:-

Continuous rating Input	450W
No load speed (rpm)	9,000
Dimensions (L x W x H)	1,110~1,310 x 310 x 260mm
Net weight	2.3kg
Power supply cord	0.3m

Standard Equipment: Safety goggles.

EM4350RH 43.0mL 4-stroke (Multi-position) Acc Pg. A210-212

Petrol Backpack Brush cutter



43.0mL 4-stroke backpack brushcutter for real professionals

- The flexible shaft between engine and shaft allowing efficiently work on slopes undulating ground or in narrow space.
- Professional-user type for superior maneuverability for heavy-duty applications in forestry and construction site area.
- Able to start/stop engine while carrying machine.
- Less recoil pulling power by mechanical decompression.
- Low vibration.

Specifications:- 

Displacement	43.0mL
Engine power	1.5kW / 2.1PS
Fuel tank	0.8L
Spindle size	M10 x 1.25LH
Sound pressure level	93dB(A)
Sound power level	111dB(A)
Vibration level Front handle	3.4m/s ²
Vibration level Rear handle	2.4m/s ²
Dimensions (L x W x H)	358x280x587mm (14-1/8"x11"x23-1/8")
Net weight	12.0kg (26.6lbs)

Standard Equipment: Tool set

EE2650H 25.4mL 4-stroke (Multi-position) Acc Pg. A210

Petrol Edger



Equipped with environment-friendly and cost-saving 25.4cc 4-stroke engine.





- Multi-position engine lubrication system.
- Straight shaft (solid shaft).
- Plate on gear housing for protection against contact to concrete etc.

Specifications:- 

Displacement	25.4mL
Engine power	0.77kW / 1.1PS
Fuel tank	0.6L
Sound pressure level	88.6dB(A)
Sound power level	98.4dB(A)
Vibration level Front handle	3.7m/s ²
Vibration level Rear handle	8.8m/s ²
Dimensions (L x W x H)	1,773x242x315mm (69-3/4"x9-1/2"x12-3/8")
Net weight	6.6kg (14.6lbs)

Standard Equipment: Socket wrench, Hex wrench

Product Comparison Chart - Petrol Brush Cutter

	 String Trimmer / Brush Cutter	 String Trimmer	 Brush Cutter	 Brush Cutter	 Backpack Brush Cutter
	EM2500U	RST250	EM2650UH	RBC411U	EM4350RH
Displacement	24.5mL	24.5mL	24.5mL	40.2mL	43mL
Engine	2 Stroke	2 Stroke	<i>MM4</i>	2 Stroke	<i>MM4</i>
Engine power	0.73kW	0.73kW	0.77kW	1.40kW	1.5kW
Fuel tank	0.5L	0.5L	0.6L	1.1L	0.8L
Overall length	1,770mm	1,490mm	1,765mm	1,710mm	358mm
Net weight	4.5kg	4.2kg	5.5kg	7.3kg	12kg
Handle type	Bike	Loop	Bike	Bike	Loop
Primer pump	✓	✓	✓		✓
Rapid start					✓
Anti vibration					✓
Decompression valve			✓		✓

- CORDLESS
- FIXING / FASTENING
- DRILLING / IMPACT DRILLING
- CONCRETE DRILLING / DEMOLITION
- CUTTING [CONCRETE/ MASONRY/ METAL]
- MULTI TOOL
- GRINDING
- SANDING / POLISHING
- SAWING
- ROUTERING / PLANING
- CLEANING
- HEAT GUN / LASERS
- PNEUMATIC TOOLS
- GARDEN TOOLS
- GENERATORS

Grass Shears

CORDLESS

FIXING / FASTENING

DRILLING / IMPACT DRILLING

CONCRETE DRILLING / DEMOLITION

CUTTING [CONCRETE/ MASONRY/ METAL]

MULTI TOOL

GRINDING

SANDING / POLISHING

SAWING

ROUTERING / PLANING

CLEANING

HEAT GUN / LASERS

PNEUMATIC TOOLS

GARDEN TOOLS

GENERATORS



Grass shears DUM604 & UM600D can be easily converted to hedge trimmer by simply replacing the grass shear blade with the optional hedge trimmer blade for a wide variety of purposes.

for Hedge
2-Tools in One
for Grass

DUM604

Acc Pg. A209-210

18V LXT - Lithium-ion Cordless Grass Shear



18V LXT Li-Ion Cordless 16 cm Grass Shear

- Ergonomically designed handle with sure grip provides more control and comfort
- Grass receiver for reduced grass clean-ups
- Up to 250 min of run time on a single battery BL1860B charge
- 2,500 SPM for efficient cutting
- 2 in 1: Both trimmer blade and shear blade can be attached

Specifications:-

Cutting Width	160 mm
Depth Adjustment	15, 20, 25 mm
Strokes Per Minute (SPM)	2,500
Continuous Use (min.)	with BL1860B / BL1850B/ BL1830B: 250 / 200 / 125min
Sound Pressure Level	76 dB(A)
Vibration Level	2.5 m/s ² or less
Dimensions (L x W x H)	337x177x131 mm
Net weight	1.8 kg

Standard Equipment: Grass shear blade, Grass Receiver, Blade Cover, Hedge Trimmer Blade (only with "z" variant)

AVAILABLE VARIANTS		
5.0Ah	3.0Ah	"Z" VARIANT
DUM604 RT INCLUDES 1 BATTERIES / 1 CHARGER + GRASS SHEAR BLADE	-	DUM604 ZX TOOL + GRASS SHEAR BLADE + HEDGE TRIMMER BLADE ONLY (DOES NOT INCLUDE BATTERY / CHARGER)

UM600D

Acc Pg. A209-210

12V MAX CXT - Lithium-ion Cordless Grass Shear



12V max CXT Li-Ion Cordless 16 cm Grass Shear

- Slimmer handle. More runtime. High performance
- Ergonomically designed handle with sure grip provides more control and comfort
- Up to 90 min of run time on a single battery BL1041B charge
- 2,500 SPM for efficient cutting
- 2 in 1: Both trimmer blade and shear blade can be attached

Specifications:-

Cutting Width	160 mm (6-5/16")
Depth Adjustment	15, 20, 25 mm
Strokes Per Minute (SPM)	2,500
Continuous Use (min.)	with BL1041B / BL1021B : 90 / 45min
Sound Pressure Level	75 dB(A)
Vibration Level	2.5 m/s ² or less
Dimensions (L x W x H)	329x177x131 mm
Net weight	1.5 kg

Standard Equipment: Grass shear blade, Grass Receiver, Blade Cover, Hedge Trimmer Blade (only with "z" variant)

AVAILABLE VARIANTS		
4.0Ah	2.0Ah	"Z" VARIANT
UM600D SM INCLUDES 1 BATTERIES / 1 CHARGER + GRASS SHEAR BLADE	-	UM600D ZX TOOL + GRASS SHEAR BLADE + HEDGE TRIMMER BLADE ONLY (DOES NOT INCLUDE BATTERY / CHARGER)

Blowers



DUB362

Acc Pg. A213

Cordless 18V+18V LXT Blower

36V LITHIUM-ION



18V X2 (36V) LXT BL Brushless Cordless Variable 6-Speed Blower

- Our most powerful cordless blower yet: Amazing 54 m/s & 13.4 m³/min operation
- Delivers up to 28 minutes of run time at 15,800RPM using 5.0Ah batteries
- 6-Stage air velocity/volume selection dial with variable speed control trigger
- 3-Stage telescopic long nozzle with adjustment range of 100 mm for user convenience

Specifications:-



Air volume	6.9-13.4m ³ /min
Air speed	27-54m/s
No load speed (rpm)	11,400-21,500
Sound power level	96dB(A)
Vibration level	0.3m/s ²
Dimensions (L x W x H)	830-930x205x295mm
Net weight	3.5kg

Standard Equipment: Nozzle, Shoulder belt.

AVAILABLE VARIANTS

5.0Ah	3.0Ah	"Z" VARIANT
-	-	DUB362 Z TOOL ONLY (DOES NOT INCLUDE BATTERY / CHARGER)

DUB363

Acc Pg. A213

18V+18V LXT Lithium-Ion Cordless Blower + Vacuum

36V LITHIUM-ION BL MOTOR XPT



50L
Dust bag
capacity

18V X2 (36V) LXT Li-Ion Cordless 2-Speed Blower + Vacuum function (can be used as a vacuum with a dust bag). Incredibly high power over 25ml engine blower

- Powerful: Amazing 65 m/s operation
- Variable trigger switch + Cruise control lever allows you to lock the variable speed control trigger at the desired power level.
- Mulching function: A shredding blade cuts sucked fallen leaves into fine mulch
- Motor interlock system: The motor does not start up until the nozzle and fan cover have been properly installed
- 3-stage telescopic long nozzle with adjustment range of 100mm



2 in 1
Blower
Vacuum

Specifications:-



Runtime*
30-75
min
BL1850B x2

Continuous run time (approx)

Max Air Volume	13.4 m ³ /min (Blower) / 12.7 m ³ /min (Vacuum)
Max Air Velocity	3.2kPa (Blower)
Max sealed suction	65 m/s (Vacuum)
No Load Speed (RPM)	0 - 7,850
Vibration level	0.8m/s ²
Sound power level	96dB(A)
Dimensions (L x W x H)	w/ 3-Stage Telescopic Long Nozzle: 737/786/836x200x415 mm
Net weight	6.6 kg

Standard Equipment: Nozzle, Vacuum Kit, Shoulder belt.

AVAILABLE VARIANTS

5.0Ah	3.0Ah	"Z" VARIANT
-	-	DUB363 ZV TOOL + VACUUM KIT (DOES NOT INCLUDE BATTERY / CHARGER)

CORDLESS

FIXING / FASTENING

DRILLING / IMPACT DRILLING

CONCRETE DRILLING / DEMOLITION

CUTTING [CONCRETE/ MASONRY/ METAL]

MULTI TOOL

GRINDING

SANDING / POLISHING

SAWING

ROUTERING / PLANING

CLEANING

HEAT GUN / LASERS

PNEUMATIC TOOLS

GARDEN TOOLS

GENERATORS

- CORDLESS
- FIXING / FASTENING
- DRILLING / IMPACT DRILLING
- CONCRETE DRILLING / DEMOLITION
- CUTTING [CONCRETE/ MASONRY/ METAL]
- MULTI TOOL
- GRINDING
- SANDING / POLISHING
- SAWING
- ROUTERING / PLANING
- CLEANING
- HEAT GUN / LASERS
- PNEUMATIC TOOLS
- GARDEN TOOLS
- GENERATORS

Acc Pg. A213

DUB361

Cordless 18V+18V LXT Blower



36V LITHIUM-ION

XPT



18V X2 (36V) LXT Li-Ion Cordless 2-Speed Blower

- Delivers up to 73 minutes of run time using two 4.0Ah 18V LXT batteries on low speed setting
- Makita-built motor produces a maximum air velocity of 93 m/s
- 2-Speed (10,000 & 17,000 RPM) design for optimum speed control
- Compact and lightweight for single handed operation
- Push button air volume selection (High / Low settings)

Specifications:-

Air volume	Hi: 4.4m ³ /min / Lo: 2.3m ³ /min
Air speed	Hi: 93m/s / Lo: 57m/s
No load speed (rpm)	Hi: 17,000 / Lo: 10,000
Sound pressure level	82.3dB(A)
Sound power level	94.7dB(A)
Dimensions (L x W x H)	905 x 141 x 194mm
Net weight	2.6kg

Standard Equipment: Nozzle, Shoulder belt.

AVAILABLE VARIANTS

5.0Ah	3.0Ah	"Z" VARIANT
-	-	DUB361 Z TOOL ONLY (DOES NOT INCLUDE BATTERY / CHARGER)

Acc Pg. A213

DUB184

18V LXT - Lithium-ion Cordless Blower



18V LITHIUM-ION

BL MOTOR XPT



18V LXT Li-Ion Powerful Cordless blower with BL motor

- Ideal for clearing fallen leaves on pavement, grass and hedge clippings or other light debris
- Efficient clearing thanks to a high-efficiency axial fan similar to that of 18Vx2 LXT model DUB362
- Variable speed control by trigger, with Cruise control lever for lock-on operation

Specifications:-

Blowing force	10.9N (with nozzle)
Max Air volume	13.0 m ³ /min (with nozzle)
Max air velocity	52.1 m/s (with nozzle)
Air pressure	5.8kPa
Air outlet diameter	ø40mm
No load speed (rpm)	0-18,000
Continuous run time	6.0Ah: 12mins / 5.0Ah: 10mins
Sound pressure level	86.6 dB(A)
Sound power level	93.5 dB(A)
Dimensions (L x W x H)	825x160x285 mm
Net weight	3kg

Standard Equipment: Nozzle, Hex Wrench

AVAILABLE VARIANTS

5.0Ah	3.0Ah	"Z" VARIANT
DUB184 RT 1 BATTERY + 1 CHARGER	-	DUB184 Z TOOL ONLY (DOES NOT INCLUDE BATTERY / CHARGER)

Acc Pg. A213

DUB185

18V LXT - Lithium-ion Cordless Blower



18V LITHIUM-ION

NEW



18V LXT Li-Ion Cordless blower with 3 variable speed and increased air volume for higher blowing efficiency

- Larger air volume has been obtained by increasing the air outlet diameter
- Compact and ergonomic design
- Lightweight for reduced operator fatigue
- Rubberized soft grip handle for increased operator comfort
- Vacuum option can enable with optional accessories

Specifications:-

Blowing force	3.1N (with nozzle)
Max Air volume	3.2m ³ /min (without nozzle)
Max air velocity	98m/s (with nozzle)
Air pressure	5.8kPa
Air outlet diameter	ø40mm
No load speed (rpm)	0-18,000
Continuous run time	5.0Ah: Hi:21 / Mi:50 / Lo: 130mins / 3.0Ah: Hi:13 / Mi:30 / Lo: 80mins
Noise level	83dB(A)
Dimensions (L x W x H)	517x156x210mm
Net weight	2.1kg

Standard Equipment: Nozzle

AVAILABLE VARIANTS

5.0Ah	3.0Ah	"Z" VARIANT
-	DUB185 RF 1 BATTERY + 1 CHARGER	DUB185 Z TOOL ONLY (DOES NOT INCLUDE BATTERY / CHARGER)

Acc Pg. A213

DUB182

18V LXT - Lithium-ion Cordless Blower



18V LITHIUM-ION



18V LXT Li-Ion Cordless Blower with 3 variable speed

- Compact and ergonomic design
- Lightweight for reduced operator fatigue
- Rubberized soft grip handle for increased operator comfort
- Vacuum option can enable with optional accessories

Specifications:-

Blowing force	2.4N (with nozzle)
Max Air volume	2.6m ³ /min (without nozzle)
Max air velocity	89m/s (with nozzle)
Air pressure	5.4kPa
Air outlet diameter	ø36mm
No load speed (rpm)	0-18,000
Continuous run time	5.0Ah: Hi:20 / Mi:42 / Lo: 125mins / 3.0Ah: Hi:12 / Mi:25 / Lo: 75mins
Noise level	87dB(A)
Dimensions (L x W x H)	525x155x212mm
Net weight	2.1kg

Standard Equipment: Nozzle

AVAILABLE VARIANTS

5.0Ah	3.0Ah	"Z" VARIANT
-	-	DUB182 Z TOOL ONLY (DOES NOT INCLUDE BATTERY / CHARGER)

UB100D Acc Pg. A213

12V MAX CXT Lithium-ion Cordless Blower



Compact cordless Blower Powered by Slide Li-ion Battery of Makita's 12Vmax Platform

- Variable speed control by trigger
- 3 air volume settings: Low, Medium, High
- Compact and lightweight design
- Ergonomic soft grip
- Vacuum function - can be used as a vacuum with a dust bag.

Specifications:-

Blowing Force	1.8 N
Max Air Volume	2.6 m³/min
Max Air Velocity	75 m/s
Max Sealed Suction	4.0 kPa
No Load Speed (RPM)	0 - 15,800
Run Time (min)	High / Mid / Low
Noise K Factor	3 dB(A)
Vibration Level	508 x 155 x 202 mm (with 4.0Ah)
Dimensions (L x W x H)	2.5 m/s² or less
Net weight	1.9kg (with 4.0Ah)

Standard Equipment: Rubber Nozzle

AVAILABLE VARIANTS		
4.0Ah	2.0Ah	"Z" VARIANT
		UB100D Z TOOL ONLY (DOES NOT INCLUDE BATTERY / CHARGER)

UB1103 Acc Pg. A213 303

Electric Blower



High output air volume

- Ergonomic designed handle with elastomer for more comfortable and controlled operation.
- With optional dust bag which allows to use as a vacuum.
- Self-standing design to put on the flat place/ turn upside down
- With variable speed control dial.

Specifications:-

Continuous rating Input	600W
Air volume	0-4.1m³/min
Air pressure	0-5.7kPa (0-580mm H2O)
No load speed (rpm)	0-16,000
Dimensions (L x W x H)	479x185x178mm (18-7/8"x7-1/4"x7")
Net weight	2.0kg (4.3bs)
Power supply cord	2.5m (8.2ft)

Standard Equipment: Nozzle assembly

UB1102 Acc Pg. A213 303

Electric Blower



High output air volume

- Ergonomic designed handle with elastomer for more comfortable and controlled operation.
- With optional dust bag which allows to use as a vacuum.
- Self-standing design to put on the flat place/ turn upside down

Specifications:-

Continuous rating Input	600W
Air volume	4.1m³/min
Air pressure	5.7kPa (580mm H2O)
No load speed (rpm)	16,000
Dimensions (L x W x H)	479x185x178mm (18-7/8"x7-1/4"x7")
Net weight	2.0kg (4.3bs)
Power supply cord	2.5m (8.2ft)

Standard Equipment: Nozzle assembly

UB0801V Acc Pg. A213

Electric Blower with Vacuum kit



1,650 W powerful motor for high performance in vacuum and blower applications

- Converts to vacuum and leaf shredder with optional vacuum kit
- Blades on internal fan shreds the bulky leaves to reduce the collected volume in dust bag to 1/8 with optional vacuum kit mounted
- Slide switch air volume selection (High / Low settings)
- Integrated locking system ensures that the extension pipe does not come loose when you attach the vacuum pipe with the blower

Specifications:-

Continuous rating input	1,650W
Max Air Volume (Blower)	High / Low: 7.1 / 3.6 m³/min
Max Air Velocity (Blower)	High / Low: 83 / 42 m/s
Max Air Volume (Vacuum)	11 m³/min
Air Pressure	4.1 kPa
Dust Bag Capacity	35 L
No Load Speed (RPM)	High / Low: 17,000 / 9,000
Vibration Level	2.5 m/s² or less
Sound Pressure Level	90.4 dB(A)
Sound Power Level	104.2 dB(A)
Dimensions (L x W x H)	with Blower Nozzle: 810x220x300 mm with Vacuum Nozzle: 1,180x220x560 mm
Net weight	with Blower Nozzle: 3.2 kg with Vacuum Nozzle: 3.8 kg
Power supply cord	2.5 m

Standard Equipment: Blower Nozzle, Vacuum pipes, Dust Bag

- CORDLESS
- FIXING / FASTENING
- DRILLING / IMPACT DRILLING
- CONCRETE DRILLING / DEMOLITION
- CUTTING [CONCRETE/ MASONRY/ METAL]
- MULTI TOOL
- GRINDING
- SANDING / POLISHING
- SAWING
- ROUTERING / PLANING
- CLEANING
- HEAT GUN / LASERS
- PNEUMATIC TOOLS
- GARDEN TOOLS
- GENERATORS

Petrol Backpack Blower

Low vibration for reduced operator stress and fatigue



HIGH AIR SPEED

EB5300TH : 98 m/s
EB7660TH : 92 m/s

HIGH AIR VOLUME

EB5300TH : 15 m³/min
EB7660TH : 20 m³/min



Easy-to-pull recoil starter

Tube-mounted throttle



Comfortable backpack harness

Cushioning back padding and shoulder straps are well-ventilated for effective sweat evaporation.



Adjust straps to provide a perfect fit for every user.



EB5300TH 52.5 mL 4-stroke Tube-mounted throttle Acc Pg. A213

Petrol Backpack Blower

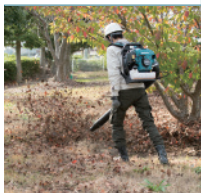

52.6 mL MM4 Backpack Blower, Tube Throttle

- 98 m/s high air speed with 15 m³/min high volume MM4 engine for lower emissions and greater fuel economy for the demanding professional
- Heavy duty anti-vibration mounts between frame and engine for improved operator comfort
- Padded shoulder straps engineered with multiple adjustments for improved fit
- Padded back panel is ventilated for improved operator comfort
- Powerful fuel efficient 52.6 mL MM4 commercial duty engine

Specifications:-

Displacement	52.5 mL
Power Rating	1.8 kW
Max Air Volume	15 m ³ /min
Max Air Velocity	98 m/s
Fuel Tank Capacity	1.8 L
No Load Speed (RPM)	2,800 - 6,400
Sound Pressure Level	96.0 dB(A)
Sound Power Level	102.5 dB(A)
Dimensions (L x W x H)	320x450x475 mm
Net weight	9.8kg

Standard Equipment: Oil bottle set, Box Wrench, Driver, Flexible Pipe, Swivel Pipe, Hose Clamp, End nozzle, Flat Nozzle, Long Pipe, Short Pipe, Accessory Bag, Cable Holder

EB7660TH 75.6 mL 4-stroke Tube-mounted throttle Acc Pg. A213

Petrol Backpack Blower



75.6 mL MM4 Backpack Blower, Tube Throttle

- 92 m/s high air speed with 20 m³/min high volume MM4 engine for lower emissions and greater fuel economy for the demanding professional
- Heavy duty anti-vibration mounts between frame and engine for improved operator comfort
- Padded shoulder straps engineered with multiple adjustments for improved fit
- Padded back panel is ventilated for improved operator comfort
- Powerful fuel efficient 75.6 mL MM4 commercial duty engine

Specifications:-

Displacement	75.6 mL
Power Rating	3.0 kW
Max Air Volume	20 m ³ /min
Max Air Velocity	92 m/s
Fuel Tank Capacity	1.9 L
No Load Speed (RPM)	2,800 - 7,200
Sound Pressure Level	102.8 dB(A)
Sound Power Level	110.7 dB(A)
Dimensions (L x W x H)	332x460x480 mm
Net weight	11.9kg

Standard Equipment: Oil bottle set, Box Wrench, Driver, Flexible Pipe, Swivel Pipe, Hose Clamp, End nozzle, Flat Nozzle, Long Pipe, Short Pipe, Accessory Bag, Cable Holder

BHX2500 24.5mL - 4 Stroke Acc Pg. A213

Petrol Blower



Take the hard work out of clearing leaves and garden debris.

- Clean exhaust emission and low fuel consumption.
- Compact and light weight.
- Mechanical decompression system for easy recoil pulling.
- Slim body for comfortable handling.

Specifications:-

Displacement	24.5 mL
Power Rating	0.81 kW
Max Air Volume	10.1 m ³ /min
Max Air Velocity	65 m/s
Fuel Tank Capacity	0.52 L
Sound Pressure Level	88.7 dB(A)
Sound Power Level	102 dB(A)
Vibration Level	5.2 m/s ²
No Load Speed (RPM)	3,500 - 7,800
Dimensions (L x W x H)	350x231x368 mm
Net weight	4.5 kg

Standard Equipment: Pipe, Nozzle, Socket Wrench

PM7650H 75.6mL 4-stroke Acc Pg. A213

Petrol Backpack Mist Blower



75.6 mL MM4 Mist Blower

- Efficient 4-Stroke Engine, No Fuel Mix Required
- Powerful fuel efficient 75.6 cc (3.67 HP), MM4 4-stroke, commercial duty engine
- L-shaped chemical tank lowers center of gravity for improved balance
- Single action switch to activate liquid chemical flow
- Padded shoulder straps retain their shape for easier re-shouldering

Specifications:-

Displacement	75.6 mL
Fuel Tank Capacity	1.8 L
Max Air Volume	14.1 m ³ /min
The velocity of the wind (without blower pipes)	85 m/s
Sound Pressure Level	98.3 dB(A)
Sound Power Level	110.7 dB(A)
Vibration Level	3.5 m/s ²
Dimensions (L x W x H)	420x440x595 mm
Net weight	13.9 kg

Standard Equipment: Oil bottle, Hand strap, Screwdriver, Diffusion cover, Hose clamp, Flexible pipe, Straight pipe

- CORDLESS
- FIXING / FASTENING
- DRILLING / IMPACT DRILLING
- CONCRETE DRILLING / DEMOLITION
- CUTTING [CONCRETE/ MASONRY/ METAL]
- MULTI TOOL
- GRINDING
- SANDING / POLISHING
- SAWING
- ROUTERING / PLANING
- CLEANING
- HEAT GUN / LASERS
- PNEUMATIC TOOLS
- GARDEN TOOLS
- GENERATORS

Lawn Mowers



CORDLESS

FIXING / FASTENING

DRILLING / IMPACT DRILLING

CONCRETE DRILLING / DEMOLITION

CUTTING [CONCRETE/ MASONRY/ METAL]

MULTI TOOL

GRINDING

SANDING / POLISHING

SAWING

ROUTERING / PLANING

CLEANING

HEAT GUN / LASERS

PNEUMATIC TOOLS

GARDEN TOOLS

GENERATORS

DLM382 Plastic Deck | Push Type

Acc Pg. A212

18V+18V LXT Cordless Lawn Mower



18vx2 380mm Cordless Lawn Mower with better usability.

- Grass box with grass level indicator
- Single-lever cutting height adjustment
- Easy installation and removal of the grass box
- Child lock key
- Single speed mode

Runtime
35min
BL1860B x2

560 m²

Recommended mowing area
BL1860B x2

Specifications:-



Cutting Width	380 mm
Cutting Height	20 - 75 mm
Deck Type	Plastic
No. of stages	13 stages
No Load Speed (RPM)	3,700
Dimensions (L x W x H)	1,380-1,410x450x985-1,005 mm
Net weight	16.9 kg

Standard Equipment: Socket wrench

AVAILABLE VARIANTS

5.0Ah	3.0Ah	"Z" VARIANT
		DLM382 Z TOOL ONLY (DOES NOT INCLUDE BATTERY / CHARGER)

DLM431 Plastic Deck | Push Type

Acc Pg. A212

18V+18V LXT Cordless Lawn Mower



18vx2 430mm Cordless Lawn Mower with better usability.

- Grass box with grass level indicator
- Single-lever cutting height adjustment
- Built-in ball bearing on axles for added durability
- Child lock key
- 2-speed mode

Runtime
30min
BL1850B x2

475 m²

Recommended mowing area
BL1850B x2

Specifications:-



Cutting width	430mm (17")
Cutting height	20-75mm
No load speed (rpm)	3,600
Recommended mowing area	500-1,000m ²
Grass box capacity	50L
Dimensions (L x W x H)	1,450x460x950mm
Max output	730W
Net weight	18.0kg

Standard Equipment: Socket wrench,

AVAILABLE VARIANTS

5.0Ah	3.0Ah	"Z" VARIANT
DLM431 PT2 INCLUDES 2 BATTERIES / 1 TWO PORT CHARGER		DLM431 Z TOOL ONLY (DOES NOT INCLUDE BATTERY / CHARGER)

DLM460 Steel Deck | Push Type Acc Pg. A212

18V+18V LXT Cordless Lawn Mower



- 18vx2 460mm Cordless Lawn Mower with better usability.**
- 3 in 1 (Cutting, Collecting, Mulching)
 - Grass box with grass level indicator
 - Single-lever cutting height adjustment
 - Built-in ball bearing on axles for added durability
 - Child lock key
 - 2-speed mode
 - IPX4 : water resistant

Runtime **21min**
BL1860B x2

800 m²

Recommended mowing area BL1860B x2

Specifications:-

Blade Type	2 Cutting Edges
Hole Diameter	10.0 mm (3/8")
Cutting Width	460 mm (18")
Cutting Height	20 - 75 mm (13/16" - 2-5/16")
No Load Speed (RPM)	2,500 - 3,300
Recommended mowing area	6.0Ah x2: 800 - 1,600 m ² / 5.0Ah x2: 680 - 1,360 m ²
Continuous Use (min.)	6.0Ah: 21min / 5.0Ah: 18min / 3.0Ah: 10min
Dimensions (L x W x H)	During operation: 1,319-1,518x532x879-1,138 mm
Net weight	27.6 kg

Standard Equipment: Socket wrench

AVAILABLE VARIANTS		
5.0Ah	3.0Ah	"Z" VARIANT
-	-	DLM460 Z TOOL ONLY (DOES NOT INCLUDE BATTERY / CHARGER)

DLM531 Steel Deck | Push Type | Side Discharge Acc Pg. A212

18V+18V LXT Cordless Lawn Mower with 4 battery slots



- 18vx2 430mm Cordless Lawn Mower with better usability.**
- Optimum blade design for less rotational speed reduction of the blade
 - Enhanced rigidity of handle
 - Grass box with grass level indicator
 - Single-lever cutting height adjustment
 - Built-in ball bearing on axles for added durability
 - Child lock key
 - 2-speed mode
 - Large grass discharge port

Runtime **50min**
BL1860B x4

2,300 m²

Recommended mowing area BL1860B x2

Specifications:-

Cutting Width	534 mm
Cutting Height	20 - 100 mm
Deck Type	Steel
No. of stages	10 stages
No Load Speed (RPM)	2,300 - 2,800
Propelling speed	2.5 - 5.0 km/h
Dimensions (L x W x H)	1,630-1,715x590x990-1,095 mm
Net weight	38.3 kg

Standard Equipment: Side Discharge, Socket wrench

AVAILABLE VARIANTS		
5.0Ah	3.0Ah	"Z" VARIANT
-	-	DLM531 Z TOOL ONLY (DOES NOT INCLUDE BATTERY / CHARGER)

DLM532 Steel Deck | Self Propelled | Side Discharge Acc Pg. A212

18V+18V LXT Cordless Lawn Mower with 4 battery slots



- 18vx2 430mm Cordless Lawn Mower with better usability.**
- Optimum blade design for less rotational speed reduction of the blade
 - Enhanced rigidity of handle
 - Grass box with grass level indicator
 - Single-lever cutting height adjustment
 - Built-in ball bearing on axles for added durability
 - Child lock key
 - 2-speed mode

Runtime **40min**
BL1860B x4

2,300 m²

Recommended mowing area BL1860B x2

Specifications:-

Cutting Width	534 mm
Cutting Height	20 - 100 mm
Deck Type	Steel
No. of stages	10 stages
No Load Speed (RPM)	2,300 - 2,800
Propelling speed	2.5 - 5.0 km/h
Dimensions (L x W x H)	1,630-1,715x590x990-1,095 mm
Net weight	42.9 kg

Standard Equipment: Side Discharge, Socket wrench

AVAILABLE VARIANTS		
5.0Ah	3.0Ah	"Z" VARIANT
-	-	DLM532 Z TOOL ONLY (DOES NOT INCLUDE BATTERY / CHARGER)

DLM533 Aluminium Deck | Self Propelled | Rear Discharge Acc Pg. A212

18V+18V LXT Cordless Lawn Mower with 4 battery slots



- 18vx2 460mm Cordless Lawn Mower with better usability.**
- 3 in 1 (Cutting, Collecting, Mulching)
 - Grass box with grass level indicator
 - Single-lever cutting height adjustment
 - Built-in ball bearing on axles for added durability
 - Child lock key
 - 2-speed mode
 - IPX4 : water resistant

Runtime **40min**
BL1860B x4

2,300 m²

Recommended mowing area BL1860B x2

Specifications:-

Cutting Width	534 mm
Cutting Height	20 - 100 mm
Deck Type	Aluminium
No. of stages	10 stages
No Load Speed (RPM)	2,300 - 2,800
Propelling speed	2.5 - 5.0 km/h
Dimensions (L x W x H)	1,655-1,740x590x990-1,100 mm
Net weight	47.9 kg

Standard Equipment: Socket wrench

AVAILABLE VARIANTS		
5.0Ah	3.0Ah	"Z" VARIANT
-	-	DLM533 Z TOOL ONLY (DOES NOT INCLUDE BATTERY / CHARGER)

- CORDLESS
- FIXING / FASTENING
- DRILLING / IMPACT DRILLING
- CONCRETE DRILLING / DEMOLITION
- CUTTING [CONCRETE/ MASONRY/ METAL]
- MULTI TOOL
- GRINDING
- SANDING / POLISHING
- SAWING
- ROUTERING / PLANING
- CLEANING
- HEAT GUN / LASERS
- PNEUMATIC TOOLS
- GARDEN TOOLS
- GENERATORS

- CORDLESS
- FIXING / FASTENING
- DRILLING / IMPACT DRILLING
- CONCRETE DRILLING / DEMOLITION
- CUTTING [CONCRETE/ MASONRY/ METAL]
- MULTI TOOL
- GRINDING
- SANDING / POLISHING
- SAWING
- ROUTERING / PLANING
- CLEANING
- HEAT GUN / LASERS
- PNEUMATIC TOOLS
- GARDEN TOOLS
- GENERATORS

ELM3320 330mm
Acc Pg. A212

Electric Lawn Mower

Type: Push
Deck: Plastic



Series motor

- Designed to stand upright for easy maintenance and storage
- D-shaped cutting height adjusting lever
- Improved mowing efficiency
- Improved grass collection efficiency
- Light weight plastic deck.
- Smooth running

Specifications:-

Continuous rating input	1,200W
Motor	Universal
Cutting Width	330 mm (13")
Cutting Height	20 - 55 mm (13/16" - 2-3/16")
No Load Speed (RPM)	3,400
Recommended mowing area up to	400 m ²
Grass box capacity	30 L
Wheel Size Front / Rear:	139 / 178 mm (5-1/2 / 7")
Vibration Level	2.5 m/s ² or less
Sound Pressure Level	83 dB(A)
Sound Power Level	94 dB(A)
Dimensions (L x W x H)	1,230x380x870 - 1,100 mm
Net weight	10.2 kg

Standard Equipment: Blade, Wrench

ELM3720 370mm
Acc Pg. A212

Electric Lawn Mower

Type: Push
Deck: Plastic



Series motor

- Designed to stand upright for easy maintenance and storage
- D-shaped cutting height adjusting lever
- Improved mowing efficiency
- Improved grass collection efficiency
- Light weight plastic deck.
- Smooth running

Specifications:-

Continuous rating input	1,400W
Motor	Universal
Cutting Width	370 mm (14-1/2")
Cutting Height	20 - 55 mm (13/16" - 2-3/16")
No Load Speed (RPM)	3,400
Recommended mowing area up to	500 m ²
Grass box capacity	40 L
Wheel Size Front / Rear:	139 / 178 mm (5-1/2 / 7")
Vibration Level	2.5 m/s ² or less
Sound Pressure Level	83 dB(A)
Sound Power Level	94 dB(A)
Dimensions (L x W x H)	1,330x415x890 - 1,120 mm
Net weight	11.6 kg

Standard Equipment: Blade, Wrench

ELM4110 410mm
Acc Pg. A212

Electric Lawn Mower

Type: Push
Deck: Steel



Increased maneuverability.

- Cutting height can be adjusted at 5 stages.
- Light weight grass box.
- Large throttle knob is easy to grip.
- Plastic front cover protects the steel deck.

Specifications:-

Continuous rating Input	1,600W
Cutting width	410mm (16-1/8")
Cutting height	20, 32, 44, 60, 75mm (3/4", 1-1/4", 1-3/4", 2-3/8", 3")
Recommended mowing area	600m ²
Grass box capacity	50L
Dimensions (L x W x H)	760 x 500 x 410mm (30" x 19-3/4" x 16-1/8")
Net weight	25.8kg (56.9lbs)

ELM4612 460mm
Acc Pg. A212

Electric Lawn Mower

Type: Push
Deck: Steel



Increased maneuverability.

- Wheels tucked under body to enhance performance & to cut grass close to fences, curbs, walls etc
- Cutting height can be adjusted at 8 stages.
- Grass box full indicator
- Compact & Stylish design
- Plastic front cover protects the steel deck.
- Easy to grip large throttle knob.

Specifications:-

Continuous rating Input	1,800W
Cutting width	460mm (18-1/8")
Cutting height	20, 25, 30, 38, 46, 55, 64, 75mm
Recommended mowing area	800m ²
Grass box capacity	60L
Dimensions (L x W x H)	785 x 560 x 380mm (31" x 22" x 15")
Net weight	29.5kg (65.0lbs)

Standard Equipment: Muching kit, Hex Wrench.

ELM4613 460mm Self Propelling Function Acc Pg. A212

Electric Lawn Mower

Type: Self propelled
Deck: Steel



Self propelled electric lawn mower with rear wheel drive.

- Wheels tucked under body to enhance performance & to cut grass close to fences, curbs, walls etc
- Cutting height can be adjusted at 8 stages.
- Grass box full indicator
- Compact & Stylish design
- Plastic front cover protects the steel deck.
- Easy to grip large throttle knob.

Specifications:- 

Continuous rating Input	1,800W
Cutting width	460mm (18-1/8")
Cutting height	20, 25, 30, 38, 46, 55, 64, 75mm
Propelling speed	3.6km/h
Recommended mowing area	1,000m ²
Grass box capacity	60L
Dimensions (L x W x H)	785 x 560 x 380mm (31" x 22" x 15")
Net weight	32.5kg

Standard Equipment: Mushing kit, Hex Wrench.

PLM4120N 410mm Acc Pg. A212

Petrol Lawn Mower

Type: Push
Deck: Steel



Increased maneuverability.

- Light weight grass box.
- Cutting height can be adjusted at 5 stages by one handle.
- Large throttle knob is easy to grip.
- Rubber tire for gripping lawn.
- Plastic front cover protects the steel deck.

Specifications:- 

Engine	B&S500E, 140mL
Cutting width	410mm (16-1/8")
Cutting height	25, 31, 43, 56, 70mm
Recommended mowing area	1,000m ²
Grass box capacity	50L
Dimensions (L x W x H)	760 x 500 x 410mm
Net weight	26.0kg (57.3lbs)

Standard Equipment: Mushing Plug

PLM4620N2 460mm Acc Pg. A212

Petrol Lawn Mower

Type: Push
Deck: Steel



Powerful engine and more efficient performance

- Powerful Briggs & Stratton Engine with ReadyStart function for Easy Start
- Edge trimming feature: able to cut close to walls and around obstacles obtained by offsetting blade position
- 2-in-1 feature for mulching and rear-discharging
- Ergonomic handle and soft grip for easy maneuvering
- Brake for maximum productivity and increased operator safety
- Single-lever cutting height adjustment with 5 positions

Specifications:- 

Engine	B&S625E R/S, 150mL
Cutting width	460mm
Cutting height	25, 31, 43, 56, 70mm
Recommended mowing area	Push type
Grass box capacity	1,200m ²
Dimensions (L x W x H)	60L
Net weight	800x540x400mm 27.6 kg

Standard Equipment: Mulch Plug.

PLM4621N2 460mm Self propelling (single speed) Acc Pg. A212

Petrol Lawn Mower

Type: Self Propelled
Deck: Steel



Self propelled, Powerful engine and more efficient performance

- Powerful Briggs & Stratton Engine with ReadyStart function for Easy Start
- Edge trimming feature: able to cut close to walls and around obstacles obtained by offsetting blade position
- 2-in-1 feature for mulching and rear-discharging
- Ergonomic handle and soft grip for easy maneuvering
- Brake for maximum productivity and increased operator safety
- Single-lever cutting height adjustment with 5 positions

Specifications:- 

Engine	B&S650EXI R/S, 163mL
Cutting width	460mm
Cutting height	25, 31, 43, 56, 70mm
Propelling speed	Self propelling (1 speed)
Recommended mowing	1,400m ²
Grass box capacity	60L
Dimensions (L x W x H)	800x540x410mm
Net weight	31.0 kg

Standard Equipment: Mulch Plug.

- CORDLESS
- FIXING / FASTENING
- DRILLING / IMPACT DRILLING
- CONCRETE DRILLING / DEMOLITION
- CUTTING [CONCRETE/ MASONRY/ METAL]
- MULTI TOOL
- GRINDING
- SANDING / POLISHING
- SAWING
- ROUTERING / PLANING
- CLEANING
- HEAT GUN / LASERS
- PNEUMATIC TOOLS
- GARDEN TOOLS
- GENERATORS

CORDLESS

FIXING / FASTENING

DRILLING / IMPACT DRILLING

CONCRETE DRILLING / DEMOLITION

CUTTING [CONCRETE/ MASONRY/ METAL]

MULTI TOOL

GRINDING

SANDING / POLISHING

SAWING

ROUTERING / PLANING

CLEANING

HEAT GUN / LASERS

PNEUMATIC TOOLS

GARDEN TOOLS

GENERATORS

PLM4622N 460mm (18-1/8") Self propelling

Petrol Lawn Mower

Type: Self Propelled
Deck: Steel



Self propelled petrol lawn mower.

- Light weight grass box.
- Cutting height can be adjusted at 5 stages by one handle.
- Large throttle knob is easy to grip.
- Rubber tire for gripping lawn.
- Plastic front cover protects the steel deck.

Specifications:-



Engine	B&S675EX S/R, 190mL
Cutting width	460mm (18-1/8")
Cutting height	25, 31, 43, 56, 70mm
Propelling speed	3 - 4.5km/h
Recommended mowing	1,800m ²
Grass box capacity	60L
Dimensions (L x W x H)	810 x 560 x 440mm (31-8/9" x 22" x 17-1/3")
Net weight	35.4kg (78.0lbs)

Standard Equipment: Mulch Plug.

PLM5113N2

Petrol Lawn Mower

Type: Self Propelled
Deck: Steel



Self propelled, Powerful engine and more efficient performance

- Powerful Briggs & Stratton Engine with ReadyStart function for Easy Start
- Edge trimming feature: able to cut close to walls and around obstacles obtained by offsetting blade position
- 3-in-1 feature for mulching and rear-discharging and side discharging
- Ergonomic handle and soft grip for easy maneuvering
- Brake for maximum productivity and increased operator safety
- Single-lever cutting height adjustment with 5 positions

Specifications:-



Engine	B&S675EX1 R/S, 163mL
Cutting width	510mm
Cutting height	25, 31, 40, 53, 70mm
Propelling speed	Self propelling (3 speed)
Recommended mowing	2,000m ²
Grass box capacity	65L
Dimensions (L x W x H)	890x570x440mm
Net weight	36kg

Standard Equipment: Mulch Plug.

PLM4630N2

Petrol Lawn Mower

Type: Push type
Deck: Steel



Premium class lawnmower with more functions for easy and powerful work

- Aluminum handle angle adjuster of aluminum. Powerful OHV engine with ready start function for easy start
- Makita metallic blue deck. Rubber tire for good gripping lawn
- Side-discharge is available with offset blade.
- Central height adjustment with 8 positions. Glass box with level indicator.
- Ball bearing wheel.

Specifications:-



Engine	B&S675EX1 R/S, 163mL
Cutting Width	460mm (18-1/8")
Cutting Height	25-70mm (1"-2-3/4")
Propelling speed	-
Recommended mowing area up to	1,200m ²
Grass box capacity	60L
Dimensions (L x W x H)	825x540x445 mm
Net weight	30.0 kg

Standard Equipment: Mulch Plug.

PF0410

Submersible Pump

400 WATT



Professional pump for dewatering cellars, basins and garden lakes with dirt water.

- Dewater dirt water contaminated with up to 35mm particles.
- Rigid plastic housing.
- Double gasket with oil depot in between ensures long life of the engine unit.
- Float switch automatically switches off the motor to protect the pump from running dry when the water level falls below the capacity.
- Comfortable transportation with solid and ergonomically formed handle.

Specifications:-

Continuous rating Input	400W
Suction & Discharge diameter	25mm (1")
Max. pumping capacity	140 L / min (37 gal/min)
Delivery head max	5m (16ft)
Submersion depth	5m (16ft)
Min. suction level	40mm (1-4/7")
Grain size inlet	35mm (1-3/8")
Dimensions (L x W x H)	160x168x345mm (6-5/16" x 6-5/8" x 13-5/8")
Net weight	4.3kg (9.5lbs)
Power supply cord	10m (33ft)

Standard Equipment: Elbow, Adaptor.

DVF104 10L

18V LXT Cordless Garden Sprayer



18V LXT Li-Ion Cordless 10 L Garden Sprayer

- Environment-friendly with no emission and extremely low noise
- Hand valve lever with two selectable modes
- Reduced running cost with rechargeable Li-ion battery
- Compact and lightweight cordless sprayer provides easy handling and high maneuverability
- Two different nozzles included as standard equipment for added versatility

Specifications:-



Max Pressure	0.3 MPa
Chemical tank	10 L
Dimensions (L x W x H)	315x225x415 mm
Net weight	4.1 kg

Standard Equipment: Upright Double-Headed Nozzle, Wide-Angle Herbicide Nozzle, Spray Pipe Holder, Shoulder Harness

AVAILABLE VARIANTS		
5.0Ah	3.0Ah	"Z" VARIANT
		DVF104 Z TOOL ONLY (DOES NOT INCLUDE BATTERY / CHARGER)

EF1550RH 24.5mL 4-stroke (Rotary pump type)

Backpack Sprayer

Rotary pump type sprayer suitable for spraying herbicides.



- 15L chemical tank
- Wide angle herbicide nozzle

Specifications:-

Displacement	24.5mL
Fuel tank	0.5L
Max. pressure	1.18Mpa (12kgf/cm ²)
Chemical tank	15L
Dimensions (L x W x H)	354x395x570mm (13-5/8" x 15-1/2" x 22-1/2")
Net weight	7.9kg (17.4lbs)

EVH2000 24.5mL 4-stroke (Plunger pump type)

Backpack Sprayer

Plunger pump type sprayer suitable for orchards, parks, gardens etc.

- High water pressure is obtained using a plunger pump.



Features "Rapid Start" that allows to pull the starter rope with less force for extra-easy startup.

Specifications:-

Displacement	24.5mL
Fuel tank	0.5L
Max. pressure	2.5Mpa (25kgf/cm ²)
Chemical tank	20L
Dimensions (L x W x H)	380x420x635mm (15" x 16-1/2" x 25")
Net weight	9.1kg (20.1lbs)

DCU180

18V LXT Battery Powered Wheelbarrow



Moving cart powered by LXT Li-ion battery
Two variations: Carrier type and Bucket type

Flat tray (Part no: 199009-8)

Bucket tray (Part no: 199008-0)

Please note Flat bed tray or Bucket tray will not be supplied with the wheelbarrow and need to be (ordered separately)



- Able to run with even one battery thanks to parallel battery connection.

Specifications:-

Max Run Time (min)	with BL1860B: 120
Max Load Capacity	130 kg (290 lbs.)
Traveling Speed	Forward, High / Low: 0 - 3.5 / 0 - 1.5 km/h Reverse: 0 - 1 km/h
Max Climbing Capacity	12°
Dimensions (L x W x H)	When carrier is installed / During operation: 1,315x1,060x900 mm
Net weight	44.8 kg

Standard Equipment: Lock Key, Support Legs, Wrenches

AVAILABLE VARIANTS		
5.0Ah	3.0Ah	"Z" VARIANT
		DCU180 Z TOOL ONLY (DOES NOT INCLUDE BATTERY / CHARGER / FLAT OR BUCKET TRAY)

- CORDLESS
- FIXING / FASTENING
- DRILLING / IMPACT DRILLING
- CONCRETE DRILLING / DEMOLITION
- CUTTING [CONCRETE/ MASONRY/ METAL]
- MULTI TOOL
- GRINDING
- SANDING / POLISHING
- SAWING
- ROUTERING / PLANING
- CLEANING
- HEAT GUN / LASERS
- PNEUMATIC TOOLS
- GARDEN TOOLS
- GENERATORS

- CORDLESS
- FIXING / FASTENING
- DRILLING / IMPACT DRILLING
- CONCRETE DRILLING / DEMOLITION
- CUTTING [CONCRETE/ MASONRY/ METAL]
- MULTI TOOL
- GRINDING
- SANDING / POLISHING
- SAWING
- ROUTERING / PLANING
- CLEANING
- HEAT GUN / LASERS
- PNEUMATIC TOOLS
- GARDEN TOOLS
- GENERATORS



GENERATORS

Extreme reliability and durability are achieved Heavy Duty OHV engine

Longer Operation
Fuel tank realizes continuously longer operation.

15L: EG2250A, EG2850A
25L: EG4550A, EG5550A, EG6050A

Extremely easy start
No kick-back Starting system

Recoil starter:
EG2250A, EG2850A
Electric starter/ Recoil
EG4550A, EG5550A, EG6050A
(* Battery is excluded)

Indication lamp
The lamp lights up to indicate the generator is producing power.

Oil Sensor equipped as a standard

DC output
12V - 8.3A

Current meter and Voltage meter

2 AC output
50Hz - 230V

Two wheels and handles for easy mobility

EG4550A, EG5550A, EG6050A only

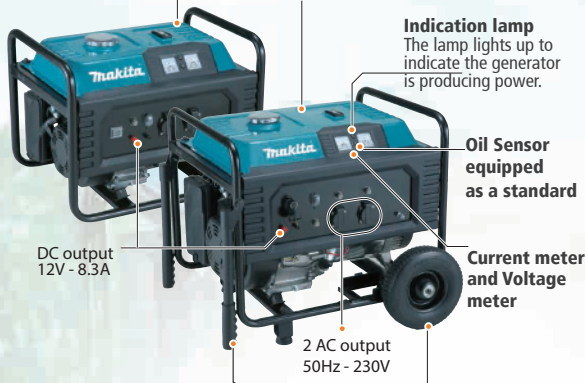

EG2250A 2.2kVA

Generator



High Performance by OHV Engine and AVR Alternator

- Extreme reliability and durability
- Fuel tank realizes continuously longer operation
- No kick-back Starting system (Recoil starter)
- Oil sensor automatically shut off the engine whenever oil level is too low

Specifications:-

Fuel tank	15L
Engine model	170F (210mL)
AC output	50Hz : 2.0kVA
Max. AC output VA	50Hz : 2.2kVA
Dimensions	600 x 442 x 450mm
Net weight	49.8kg (109.8lbs)

Standard Equipment: Accessory tool set

EG2850A 2.8kVA

Generator



High Performance by OHV Engine and AVR Alternator

- Extreme reliability and durability
- Fuel tank realizes continuously longer operation
- No kick-back Starting system (Recoil starter)
- Oil sensor automatically shut off the engine whenever oil level is too low

Specifications:-

Fuel tank	15L
Engine model	170F (210mL)
AC output	50Hz : 2.6kVA
Max. AC output VA	50Hz : 2.8kVA
Dimensions	600 x 442 x 450mm
Net weight	52.8kg (116.4bs)

Standard Equipment: Accessory tool set

EG4550A 4.5kVA

Generator



High Performance by OHV Engine and AVR Alternator

- Extreme reliability and durability
- Fuel tank realizes continuously longer operation
- No kick-back Starting system (Electric starter/ Recoil, battery is excluded)
- Oil sensor automatically shut off the engine whenever oil level is too low
- Two wheels and handles for easy mobility

Specifications:-

Fuel tank	25L
Engine model	190F (420mL)
AC output	50Hz : 4.0kVA
Max. AC output VA	50Hz : 4.5kVA
Dimensions	680 x 550 x 550mm
Net weight	95.5kg (210.5lbs)

Standard Equipment: Accessory tool set

EG5550A 5.5kVA

Generator



High Performance by OHV Engine and AVR Alternator

- Extreme reliability and durability
- Fuel tank realizes continuously longer operation
- No kick-back Starting system (Electric starter/ Recoil, battery is excluded)
- Oil sensor automatically shut off the engine whenever oil level is too low
- Two wheels and handles for easy mobility

Specifications:-

Fuel tank	25L
Engine model	190F (420mL)
AC output	50Hz : 5.0kVA
Max. AC output VA	50Hz : 5.5kVA
Dimensions	680 x 550 x 550mm
Net weight	98.5kg (217.2lbs)

Standard Equipment: Accessory tool set

EG6050A 6.0kVA

Generator



High Performance by OHV Engine and AVR Alternator

- Extreme reliability and durability
- Fuel tank realizes continuously longer operation
- No kick-back Starting system (Electric starter/ Recoil, battery is excluded)
- Oil sensor automatically shut off the engine whenever oil level is too low
- Two wheels and handles for easy mobility

Specifications:-

Fuel tank	25L
Engine model	190F (420mL)
AC output	50Hz : 5.5kVA
Max. AC output VA	50Hz : 6.0kVA
Dimensions	680 x 550 x 550mm
Net weight	100.5kg (221.6lbs)

Standard Equipment: Accessory tool set

CORDLESS

FIXING / FASTENING

DRILLING / IMPACT DRILLING

CONCRETE DRILLING / DEMOLITION

CUTTING [CONCRETE/ MASONRY/ METAL]

MULTI TOOL

GRINDING

SANDING / POLISHING

SAWING

ROUTERING / PLANING

CLEANING

HEAT GUN / LASERS

PNEUMATIC TOOLS

GARDEN TOOLS

GENERATORS

Makita - A Global Brand



Makita have established directly operated business bases in about 50 countries around the world, and have upgraded our sales network in over 170 countries and after-sales service capabilities to become one of the leading companies in our industry. In addition, Makita is producing power tools in plants in China, U.S.A., U.K., Germany, Brazil, Romania and Thailand. Currently, about 90% of our group's manufacturing work in terms of production volume is carried out overseas. Makita's worldwide sales and service network, as well as the stable, high production quality ensured at its plants worldwide, are the embodiment of the Makita brand.

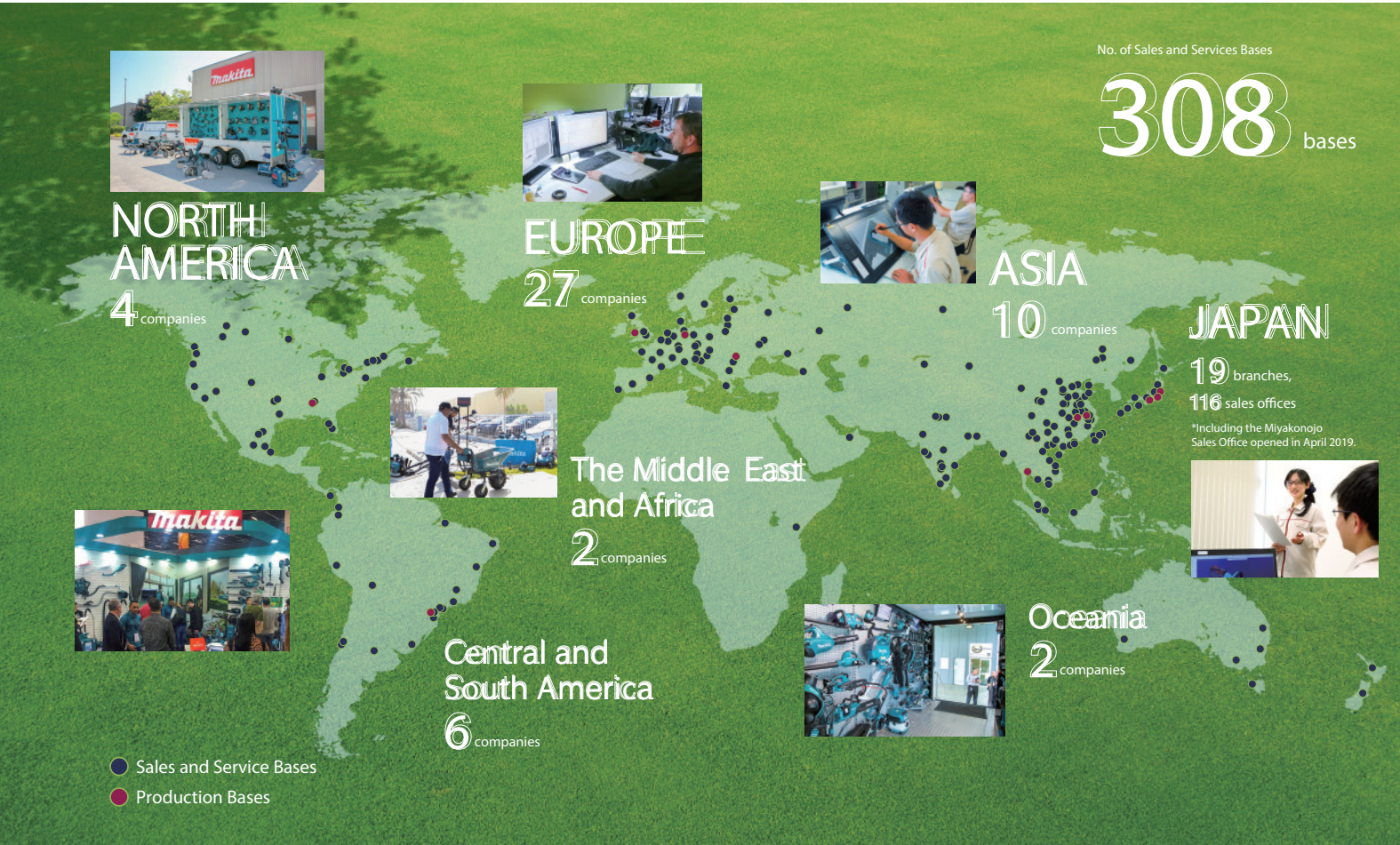

JAPAN
Makita Corporation Headquarters

JAPAN
Okazaki Plant

U.S.A.
Makita Corporation of America

UNITED KINGDOM
Makita Manufacturing Europe Ltd.

ROMANIA
SC Makita EU SRL

GERMANY
Makita Engineering Germany

BRAZIL
Makita do Brasil Ferramentas Elétricas Ltda.

CHINA
Makita (China) Co., Ltd.

CHINA
Makita (Kunshan) Co., Ltd.

THAILAND
Makita Manufacturing (Thailand) Co., Ltd.

JAPAN

Makita Corporation
Head office
3-11-8, Sumiyoshi-cho, Anjo,
Aichi 446-8502
Phone: +81-(0)566-98-1711
Fax: +81-(0)566-98-6021
www.makita.co.jp

Okazaki plant
22-1, Watarijima, Nemunoki-cho, Okazaki,
Aichi 444-0232
Phone: +81-(0)564-43-3111

Nisshin Office
349 Minamiyama, Komenoki-cho, Nisshin,
Aichi 470-0111
Phone: +81-(0)561-75-1500

Tokyo branch office
3-5-3, Hongo, Bunkyo-ku,
Tokyo 113-0033
Phone: +81-(0)3-3816-1141
Fax: +81-(0)3-3813-1633

Nagoya branch office
2-33, Namiki, Nakamura-ku,
Nagoya 453-0856
Phone: +81-(0)52-419-0561
Fax: +81-(0)52-413-0081

Osaka branch office
1-26-8, Tenma, Kita-ku,
Osaka 530-0043
Phone: +81-(0)6-6351-8771
Fax: +81-(0)6-6352-4607

Domestic sales offices
Sapporo, Sendai, Niigata, Utsunomiya,
Saitama, Chiba, Yokohama, Shizuoka, Gifu,
Kanazawa, Kyoto, Hyogo, Hiroshima,
Takamatsu, Fukuoka,
Kumamoto and other major cities

CHINA

Makita (China) Co., Ltd.
Head office & plant (MCC)
No.288 South Huangpujiang Road, Kunshan
Development Zone, Jiangsu.
Postcode:215335
Phone: +86-(0)512-57707710
Fax: +86-(0)512-57713623
www.makita.com.cn

Domestic sales department (MCS/MCCF)
No.318 South Wusongjiang Road, Kunshan
City, Jiangsu Province.
Postcode:215300
+86-(0)512-57037500
+86-(0)512-57037118
www.makita.com.cn

Guangzhou sales branch (CGZ)
Rome 1001 1002, The First Floor, Jinhao
Building, No.38, Middle Of Huadi Avenue, Li
Wan
District, Guangzhou, Guangdong, P.R.China
Phone: +86-(0)20-87518872
Fax: +86-(0)20-87518873

Shanghai sales branch (CSH)
Room.102&103, 1F, No.128, East Luoxiu
Road, Xuhui District, Shanghai, P.R.China
Phone: +86-(0)21-54487198
Fax: +86-(0)21-62476732

Tianjin sales branch (CTJ)
No.3 Office Building, No.23, Quanwang
Road, Wuqing Development
Area, Tianjin, P.R.China
Phone: +86-(0)22-29395799
Fax: +86-(0)22-29395769

Chengdu sales branch (CCD)
2F, Building 1, Hatcher Building, No.9, Wu Ke
Dong San Road, Wu Hou
District, Chengdu, Sichuan, P.R. China
Phone: +86-(0)28-85366002
Fax: +86-(0)28-87337018

Shenyang sales branch (CSY)
No.2, 10A, No.7 Street, Economic and
Technological Development Zone,
Shenyang, Liaoning, P.R. CHINA
Postcode : 110141
Phone: +86-(0)24-22530648
Fax: +86-(0)24-22530170

Xian sales branch (CXA)
1 & 2F, Xian Youzhi Science and Technology
Industrial Park NO.75 Mingguang Road,
Economic And Technological Development
Zone, Xian, Shanxi. P.R. CHINA
Postcode:710018
Phone: +86-(0)29-86223736
Fax: +86-(0)29-86229230

Changsha sales branch (CCS)
(Near Gaosheng Road)
No.3, Building 5, Youxin Mechanical And
Electrical Market, Yuhua District,
Changsha, Hunan, P.R.China
Phone: +86-(0)731-8526-7792
Fax: +86-(0)731-8526-7791

Shijiazhuang sales branch (CSJ)
No.15, F District, Wanlian International
Mechanical And Electrical City, No.560,
Heping East Road, Changan
District, Shijiazhuang, Hebei, P.R. CHINA
Postcode: 050000
Phone: +86-(0)311-89864089
Fax: +86-(0)311-85024612

Makita (Kunshan) Co. Ltd.
Nanzi Road, Kunshan Comprehensive Free
Trade Zone, Jiangsu.
Postcode: 215301
Phone: +86-(0)512-57367367
Fax: +86-(0)512-57365575

Makita Power Tools (HK) Ltd.
Head office
Unit 1, 17/F, Grandtech Centre,
8 On Ping Street, Shatin, N.T., Hong Kong
Phone: +852-2648-8683
Fax: +852-2648-5237

Macau Service Centre
Em Macau, Rua Do Volong N°11,
Rês-Do-Chão A
Phone: +853-2835-4587
Fax: +853-2835-4135
www.makita.com.hk

Makita (Taiwan) Ltd.
Head office
No.798, Sec. 2, Wenhua 3rd Rd.,
Linkou Dist., New Taipei City 24459, Taiwan
Phone: +886-(0)2-8601-9898
Fax: +886-(0)2-8601-2266
www.makita.com.tw

Taichung sales branch
No.131, Daxing Rd., Taiping Dist.,
Taichung City 411, Taiwan
Phone: +886-(0)4-2392-1650
Fax: +886-(0)4-2392-1653

Kaohsiung sales branch
No.105, Yucheng Rd., Sanmin Dist.,
Kaohsiung City 807, Taiwan
Phone: +886-(0)7-343-0292-4
Fax: +886-(0)7-341-3602

Hualien factory service center
No.247, Sec.2, Zhongyang Rd.,
Ji'an Township, Hualien County 973, Taiwan
Phone: +886-(0)3-852-8901
Fax: +886-(0)3-852-8515

Yunlin factory service center
No.197, Guangfu Rd.,
Huwei Township, Yunlin County 632, Taiwan
Phone: +886-(0)5-632-8200
Fax: +886-(0)5-632-8190

Pingtung factory service center
No.12&16, Ruimin Rd.,
Pingtung City 900, Taiwan
Phone: +886-(0)8-722-0001
Fax: +886-(0)8-722-0733

SINGAPORE

Makita Singapore Pte. Ltd.
7, Changi South Street 3,
Singapore 486348
Phone: +65-6546-8700
Fax: +65-6546-8711
www.makita.com.sg

Myanmar Service Center
No. D36/2, Lan Thit Road, Nant Thar Gone
District, Insein Township, Yangon
Phone: +95-(0)9-76232-6433
Phone: +95-(0)9-76911-5388

Cambodia Service Center
No.432, St.271,
Sangkat Tumnuop Teuk,
Khan Chamkarmon, Phnom Penh
Phone: +855-(0)23-994-071/2
Fax: +855-(0)23-994-073
https://www.makita.com.kh/

INDIA

Makita Power Tools India Pvt. Ltd.
Head Office
Unit 2, Sy. No. 93/3 & 93/4,
Koralur Village, Kasaba Hobli,
Hoskote Taluk, Bangalore – 560067, India.
Phone: +91-(0)80-2205-8200
Fax: +91-(0)80-2854-9007
www.makita.in

Delhi Branch
70/A 23, Rama Road Industrial Area,
Najafgarh Road, New Delhi – 110015, India.
Phone: +91(0)11-4701-4188

Chennai Branch
No.30, Koyambedu,
Chennai – 600107, India.
Phone: +91-(0)44-2479-2522
Fax: +91-(0)44-2479-2533

Kolkata Branch
P-46, Hide Road Extension,
Kolkata – 700088,
West Bengal, India.
Phone: +91-(0)33-2439-1030 / 1060

Bangalore Service Centre
Sowbhagya M Gopi Nilaya No. 66, Mission
Road, 2nd Main, Sudhamanagar, Bangalore
– 560027, India.
Phone: +91-80-2222-8200

Cochin Branch
Door No. XVI/443A, Jubilee Road, Kerala –
682040, India
Phone: +91(0)48-4320-0003

Mumbai Service Centre
Shop No. 11, Ground Floor, Satellite Silver,
Opp. Star Plus, Marol Naka, Andheri-Kurla
Road, Andheri (E), Mumbai – 400059, India.
Phone: +91(0)22-4974-4092

Ahmedabad Service Centre
Aniket Estate, Near Sawan Hotel, Near
Sarkhej – Sanand Chokdi, S. G. Highway,
Ahmedabad – 382210, India.
Phone: +91(0)79-2689-0111

Hyderabad Service Centre
3-3-10, Kings Way, Rashtra Pathi Road,
Secunderabad – 500003, India.
Phone: +91(0)040-4003-8000

Peenya Service Center
No. 36/B, F1, 2nd Phase, 1st Main Road,
KIADB, NTF Circle, Peenya Industrial
Area, Bangalore - 560058
Phone: Mob. +91 9606900302

Chawari Bazar Service Centre
Shop No. 4782, Bazar Ajmeri Gate, Hauz
Qazi, Delhi - 110006
Phone: Tel - 011-49145416

Pune Service Centre
Shop No. 104, First Floor, Plot No.
PAP/J/121/122, J Block, MIDC Bhoasari,
Pimpri Chinchwad, Pune - 411026
Phone: Mob. +91 7798779737

Rudrapur Service Centre
MIG-48, Ground Floor, Ward No. 19, New
Ward no. 38, Near Siddhu Palace, Awas
Vikas, Rudrapur, Uttarakhand - 263153
Phone: Mob. +91 7042597756

Trichy Factory Service Centre
NO.415, No.S1/17A, EGA PLAZA, Trichy
Tanjore Main Road, Thuvakudi, Trichy -
620015
Phone: Mob. +91 9600291989

Jamshedpur Service Centre
Shop no. 24, Shivaranjani Complex, Plot no.
ST-8, Mouzadindli, Adityapur, P.S. Adityapur
Ward no. 5, Saraikel (D), Kharswan,
Jharkhand State
Phone: Mob. +91 9830137136

Indore Service Centre
Unit No. B-34, Block No. B-18, Access B,
New Siyaganj, Poddar Plaza, HTL, Unit 2,
VIP Route No.1, Kachhi Mohalla, Indore
Phone: Mob. +91 9329217701

VIETNAM

Makita Vietnam Co. Ltd. Head office
Unit 06, Block 16 L1-L2,
Street 3, VSIP II Industrial Park,
Hoa Phu Ward, Thu Dau Mot City,
Binh Duong Province, Vietnam.
Phone: +84-274-362-8338
Fax: +84-274-362-8339
www.makita.com.vn

North Branch
Unit 05, No.01, Street 6,
VSIP Bac Ninh Intergrated
Township and Industrial Park,
Phu Chan Commune,
Tu Son Town, Bac Ninh Province, Vietnam.
Phone: +84-222-376-5942
Fax: +84-222-376-5941

Da Nang Service Center
102 Trieu Nu Vuong Street, Hai Chau 1
Ward,
Hai Chau District, Da Nang City, Vietnam.
Phone: +84-236-352-5079
Fax: +84-236-352-5479

Can Tho Service Center
226 Vo Van Kiet Street, An Thoi Ward,
Binh Thuy District, Can Tho City, Vietnam.
Phone: +84-292-389-4358
Fax: +84-292-389-4359

Buon Ma Thuot Service Center
60 Y Jut, Thong Nhat Ward, Buon Ma Thuot
City, Dak Lak Province, Vietnam.
Phone: +84-292-355-4556
Fax: +84-262-355-4557

Hai Phong Service Center
15 Pham Hong Thai, Pham Hong Thai Ward,
Hong Bang District, Hai Phong City, Viet
Nam
Phone: +84-225-883-1429/1529

Nha Trang Service Center
1053 Hai Thang Tu Street, Van Thanh Ward,
Nha Trang City, Khanh Hoa Province, Viet
Nam
Phone: +84-258-382-3338

Ho Chi Minh Branch
12 Trinh Van Can, Cau Ong Lanh Ward,
1 District, Ho Chi Minh City, Viet Nam
Phone: +84-283-821-5191

THAILAND

Makita Manufacturing (Thailand) Co., Ltd.
219/1 Moo 6, Tambol Bowin,
Amphur Sriracha, Chonburi, 20230
Phone: +66-3300-4750
Fax: +66-3300-4747

MALAYSIA

Makita Power Tools (Malaysia) Sdn. Bhd.
Head Office
Lot 824, Jalan Subang 5, Subang Industrial
Area,
47500 Subang Jaya, Selangor, Malaysia
Phone: +60-(0)3-8023-0824
Fax: +60-(0)3-8022-1448

Johor (Johor Bahru) Service Center
No. 12 & 14, Jalan Rosmerah 2/9,
Taman Johor Jaya, 81100 Johor Bahru,
Johor
Phone: +60-(0)7-364-9406
Fax: +60-(0)7-364-9407

Sarawak (Kuching) Service Center
No. 7, Lot 3330, Jalan Wan Alwi, Lorong 3A,
Taman Linang/ Suboh, 93350 Kuching
Sarawak
Phone: +60-(0)82-503-361
Fax: +60-(0)82-505-361

Sabah (Kota Kinabalu) Service Center
Lot 19, Jalan Buah Duku,
Kolombong Light Industrial Estate,
Off Kolombong, Kolombong Zone 1, 88450
Inanam, Kota Kinabalu, Sabah
Phone: +60-(0)88-388-278
Fax: +60-(0)88-388-279

AMERICAS

EUROPE

UNITED STATES

Makita U.S.A. Inc.
Corporate office
14930 Northam Street, La Mirada,
CA 90638-5753, USA
Phone: +1-714-522-8088
Fax: +1-714-522-8133
www.makitatools.com

Western regional
(Los Angeles) office
14930 Northam Street, La Mirada,
CA 90638-5753
Phone: +1-714-522-8088
Fax: +1-714-297-1544

(Western) office
10200 Military Rd, Reno, NV, 89506

Central regional
(Chicago) office
1450 Feehanville Drive, Mount Prospect,
IL 60056-6011
Phone: +1-847-297-3100
Fax: +1-847-297-1544

Eastern regional
(Atlanta) office
2660 Buford Highway, Buford,
GA 30518-6045
Phone: +1-770-476-8911
Fax: 866-521-3541
Free Dial USA only

Southern regional
(Dallas) office
910 E. Pleasant Run Road, Wilmer, TX
75172
Phone: +1-972-441-8099
Fax: +1-855-231-0468

Factory service centers
Atlanta, Boston, Chicago, Dallas, Denver,
Florida, Houston, Las Vegas, Los Angeles,
New Jersey, Portland, San Francisco

Makita Corporation of America
2650 Buford Highway, Buford,
GA 30518-6045
Phone: +1-770-932-2901
Fax: +1-770-932-2905

Makita Latin America Inc.
Head office
10801 NW 97th Street #13 Medley,
FL USA 33178
Phone: +1-305-882-0522
Fax: +1-305-882-0484
www.makitalatinamerica.com

Makita Latin America Inc.
Panama Branch
Local Comercial No.4, Albrook Office Center,
calle Diego Dominguez, Albrook,
Panama City, Panama
Phone: +507-315-0305
Fax: +507-315-0651

CANADA

Makita Canada Inc.
Head office
1950 Forbes Street, Whitby, ON L1N 7B7
Phone: +1-905-571-2200
Fax: +1-905-433-4779
www.makita.ca

Western regional office
11771 Hammersmith Way, Richmond,
BC V7A 5H6
Phone: +1-604-272-3104
Fax: +1-604-272-5416

Quebec and
Atlantic regional office
6389 Boul. Couture, St. Léonard,
Quebec H1P 3J5
Phone: +1-514-323-1223
Fax: +1-514-323-7708

Factory service centers
Burnaby (Vancouver), Calgary,
Dartmouth (Halifax), Edmonton, Les
Saulés (Quebec City),
London, Mississauga (Toronto),
Nepean (Ottawa),
Richmond (Vancouver), Saskatoon,
St. Leonard (Montreal), Whitby, Winnipeg

MEXICO

Makita México, S.A. de C.V.
Head office
Camino Viejo A San Lorenzo Tepaltitlan
(Jose Marti) No.227
Col. Tlacopa, Toluca, Estado De Mexico,
C.P. 50010
Phone: +52-722-385-8800
/ 237-3293
www.makita.com.mx

Mexico city factory service center
Norte 35 #780-C Col. Industrial Vallejo, Del.
Azcapotzalco Mexico, D.F. Mexico C.P.
02300
Phone: +52-55-5567-3387
/ 5368-2937

Guadalajara factory service center
AV.Sierra Mazamitla #5864
Col.Pinar De La Calma Zapopan, Jalisco
C.P. 45080
Phone: +52-33-3632-8032
/ 3632-8057

Monterrey factory service center
Avenida Pablo Livas #4207
Colonia Guadalupe victorina, Municipio
Guadalupe nuevo León, C.P.67180
Phone: +52-81-8372-4205
/ 8372-4193

Queretaro factory service center
Calle Av. Del Parque #1024
Col. Vista Alegre C.P.76074,
Queretaro, Queretaro
Phone: +52-442-222-6824
/ 222-9170

BRAZIL

Makita do Brasil Ferramentas Elétricas
Ltda.
Head office & plant
Rodovia BR 376, Km 506,1 - (pista norte)
Bairro Colônia Dona Luiza,
CEP 84043-450 - Ponta Grossa, PR
Phone: +55-(0)42-3302-2100
Fax: +55-(0)42-3302-2120
www.makita.com.br

São Paulo sales office
Rua Makita Brasil, 200 -Bairro Cooperativa -
São Bernardo do Campo - SP CEP
09852-080
Phone: +55-(0)11-4392-2411
/ 2199-2500
Fax: +55-(0)11-4392-2471

Bahia sales branch
Rua Itagi, 491 - Bairro
Pitangueiras - Lauro de Freitas,
BA CEP: 42701-370
Phone: +55-(0)71-3252-0154

Paraná sales branch
Rua Comendador Roseira,
499 Bairro Prado Velho,
Curitiba, PR CEP 80215-210
Phone: +55-(0)41-3333-8070

São Paulo service center
Rua Luis Gois, 111 Bairro Mirandópolis,
São Paulo, SP CEP 04043-250
Phone: +55-(0)11-5594-3900

Rio de Janeiro service center
Av. Das Américas, 2250 - Loja J/K - Barra da
Tijuca -
Rio de Janeiro, RJ CEP:22640-101
Phone: +55-(0)21-3151-7933

Pernambuco service center
Av. Marechal Mascarenhas de Moraes, 630,
Bairro Imbiribeira,
Recife, PE CEP 51170-000
Phone: +55-(0)81-3428-0210

Minas Gerais service center
Rua Juiz de Fora, 95 - Bairro Barro Preto,
Belo Horizonte, MG CEP 30180-060
Phone: +55-(0)31-2531-2017

Pará Sales Branch
Rodovia BR 316, Km 04 Loja 04-Bairro
Águas Lindas, Ananindeua / PA CEP
67020-000
Phone: +55-(0)91-3237-7186

Rio Grande do Sul service center
Av. Sertorio, 5539 - JD. Lindoia - Porto
Alegre - RS CEP: 91050-371
Phone: +55-(0)51-3344-1464

ARGENTINA

Makita Herramientas Eléctricas de
Argentina S.A.
LISANDRO DE LA TORRE 1246,
PARQUE INDUSTRIAL PILARICA,
FATIMA, PILAR PROVINCIA DE BUENOS
AIRES, CP1629
Phone: +54 (230)444-1100
Fax: +54 (230)444-1105
www.makita.com.ar

CHILE

Makita Chile Comercial Ltda.
Head Office
AVEL PARQUE 1307 PARQUE 5, MODULO 12,
SECTOR ENEA PONIENTE PUDAHUEL,
SANTIAGO, CHILE CP9031244
Phone: +56-2-2540-0400
www.makita.cl

Temuco factory service center
Av. Pedro de Valdivia #524, Temuco
Phone: +56-(0)2-2540-0460

PERU

Makita Peru S.A.
Panamericana Sur - Km. 29, Distrito de
Lurin, Provincia de Lima Centro de
Operaciones "MEGACENTRO LURIN"
Locales B1, B23, B24
Phone: +51-(1)-713-1212
www.makita.pe

Bolivia Branch
Av. Japón Nro. 3340 (3er. Anillo externo)
entre Av. Alemana y Mutualista
Phone: +59-(1)-3347-1147

COLOMBIA

MAKITA COLOMBIA S.A.S
Kilometro 7 Autopista Bogota - Medellín,
Centro Empresarial Celta Trade Park
Lote 123 Bodega 3 Funza - Cundinamarca,
Colombia
Phone: +57-1-742-9245
Fax: +57-1-896-6367
www.makita.com.co

Paloquemao factory service center
Carrera 22#18-63, Bogota,
Cundinamarca, Colombia
Phone: +57-1-742-9245 EXT.532

UNITED KINGDOM

Makita (U.K.) Ltd.
Head office
Michigan Drive, Tongwell, Milton Keynes,
Bucks MK15 8JD
Phone: +44-(0)1908-211678
Fax: +44-(0)1908-211400
www.makita.uk.com

Scotland factory service center
Unit 4A, Albion Trading Estate,
750 South Street, Glasgow, G14 0SY
Phone: +44-(0)141-9545861

London factory service center
V5 Vector Park, Forest Road, Felthm,
Middlesex, TW13 7EJ
Phone: +44-(0)20-88900586

Makita International Europe Ltd.
Michigan Drive, Tongwell, Milton Keynes,
Bucks MK15 8JD
Phone: +44-(0)1908-211678

Makita Manufacturing Europe Ltd.
Hortonwood 7, Telford, Shropshire TF1 7YX
Phone: +44-(0)1952-677688
Fax: +44-(0)1952-677678

FRANCE

Makita France SAS
Head office
37, avenue Graham Bell, ZAC Léonard de
Vinci,
Bussy Saint-Georges, 77607 Marne-la-Vallée
Cedex 3
Phone: +33-(0)1-6094-6400
Fax: +33-(0)1-6094-6380
www.makita.fr

Nantes office
Le Pan Loup, 44220 Couéron
Phone: +33-(0)2-5177-8977
Fax: +33-(0)2-4063-8376

Bordeaux office
137, Rue de la Croix-de-Monjous,
33170 Gradignan
Phone: +33-(0)5-5796-5270
Fax: +33-(0)5-5796-5275

Nord office
Village d'Entreprises, 51, Rue Trémière,
59650 Villeneuve d'Ascq
Phone: +33-(0)3-2059-7020
Fax: +33-(0)3-2047-2220

Dijon office
5, Rue Edmond Voisenet, 21000 Dijon
Phone: +33-(0)3-8054-0880
Fax: +33-(0)3-8054-0881

Toulouse office
15, Rue de Boudeville, Z.I. de Thibaud,
31104 Toulouse
Phone: +33-(0)5-6143-2200
Fax: +33-(0)5-6143-2201

SPAIN

Makita, S.A.
Head office
C/ Juan de la Cierva, 7-15,
28820 Coslada (Madrid)
Phone: +34-91-671-1262
Fax: +34-91-671-8293
www.makita.es

Barcelona factory service center
Carretera del Mig, nº 172 L'Hospitalet de
Llobregat (Barcelona)
Phone: +34-935-669-124

PORTUGAL

Makita Ferramentas Eléctricas,
Sociedade Unipessoal, Lda.
Centro empresarial de Alverca,
Vale das Ervas, Armazém C2
2615-187 Alverca do Ribatejo
Phone: +351-219-936-750
Fax: +351-219-574-982
www.makita.pt

ITALY

Makita S.p.A.
Via Sempione 269/A,
20028 San Vittore Olona (MI)
Phone: +39-0331-524111
Fax: +39-0331-420285
www.makita.it

GREECE

Makita Hellas S.A.
Tatoiou 34, Acharnes, ATTIKI PC13677
Phone: +30-210-8071241
Fax: +30-210-8072245
www.makita.gr

FINLAND

Makita Oy
Teilimäki 4 FIN-01530 Vantaa, Finland
Phone: +358-(0)9-857-880
Fax: +358-(0)9-857-88211
www.makita.fi

ESTONIA

Makita Oy Estonian Branch
Estonian office
Piirimäe 13, 76406 Saku vald, Harjumaa maakond
Phone: +372-6-510-380
Fax: +372-6-510-399
www.makita.ee

LATVIAN

Latvian factory service center
Vienības gatve 153/1, Mārupe Mārupes nov., LV-2167, LATVIA
Phone: +371 67969563

LITHUANIAN

Lithuanian factory service center
L. Zamenhofo g. 3, Vilnius, LT-06332, LITHUANIA
Phone: +370 5 236 0400

SWEDEN

Makita Sweden
Bergkällavägen 36 B
192 79 Sollentuna, Sweden.
Phone: +46-8-505-819-00
Fax: +46-8-505-819-69
www.makita.se

NORWAY

Makita Norway
Løxaveien 11A
N-1351 Rud Norway
Phone: +47-67 17 69 00
www.makita.no

THE NETHERLANDS

Makita Nederland B.V.
Park Forum 1101
5657HK Eindhoven
Phone: +31-(0)40-206-4040
Fax: +31-(0)40-206-4096
www.makita.nl

BELGIUM

S.A. Makita N.V.
Jan-Baptist Vinkstraat 2
3070 Kortenberg
Phone: +32-(0)2-257-1840
Fax: +32-(0)2-253-0101
www.makita.be

GERMANY

Makita Werkzeug GmbH
Head office
Makita Platz 1,
40885 Ratingen
Phone: +49 (0)2102 1004-0
Fax: +49 (0) 2102 1004-128
www.makita.de
https://www.dolmar.de/

Makita Service Center Hamburg

Jenfelder Strasse 38,
22045 Hamburg
Phone: +49 (0) 2102 1004-456

Makita Service Center Berlin

Gartenfelder Straße 29 – 37
Gebäude 44, 13599 Berlin

Makita Engineering Germany GmbH

Jenfelder Strasse 38,
22045 Hamburg
Phone: +49-(0)40-66986-0
Fax: +49-(0)40-66986-352
www.makita-engineering.de

DENMARK

Makita Elværktøj Danmark
Denmark office
Erhvervsbyvej 14,
8700 Horsens
Phone: +45-76-254400
Fax: +45-76-254401
www.makita.dk

SWITZERLAND

Makita SA
Chemin du Vuasset 7 CH-1028 Preverenges
Phone: +41-(0)21-811-5656
Fax: +41-(0)21-811-5678
www.makita.ch

Espace Mitteland Training Service Center

Lerchenweg 14
4538 Oberbipp
Phone: +41-(0)32 631 01 76
Fax: +41-(0)32 631 01 79

AUSTRIA

Makita Werkzeug Gesellschaft m.b.H.
Airportstraße 4, A-2401 Fischamend
Phone: +43-(0)2232-77700-0
Fax: +43-(0)2232-77700-13
www.makita.at

SLOVENIA

MAKITA d.o.o.
Brnčičeva 17, SI-1231 Ljubljana-Črnuče, Slovenia
Phone: +386(0) 590 83 600
Fax: +386(0) 590 83 601
www.makita-see.com

CROATIA

Croatia factory service center
Kreše Golika 3A, HR- 10000 Zagreb
Phone: +385 1 2078 252
www.makita-see.com

UKRAINE

Makita Ukraine LLC
Onikiyienka Oleha Str., building 61,
Brovary city, 07400
Phone: +38 (044) 494-23-70
+38 (044) 494-23-71
Fax: +38 (044) 494-23-73
www.makita.ua

POLAND

Makita Sp. z o.o.
Head office
ul. Bestwińska 103
43-346 Bielsko - Biala
Phone: +48-(0)33-484-0200
Fax: +48-(0)33-818-4059
www.makita.pl

Warsaw branch

Moszna-Parcela 29
05-840 Brwinów
Phone: +48-(0)22-177-7300

CZECH REPUBLIC

Makita, spol. s r.o.
Kaštanová 555/125d 620 00 Brno
Phone: +42-(0)5-432-16944
Fax: +42-(0)5-432-16946
www.makita.cz

Prague Service Center

K Bílému Vrchu 3040/16, 193 00 Prague 9
Phone: +42-(0)2-991-40585

SLOVAKIA

Makita s.r.o.
Jegorovova 35
974 01 Banská Bystrica
Phone: +421-(0)48-4161-772
Fax: +421-(0)48-4161-769
www.makita.sk

HUNGARY

Makita Elektromos Kíségértékesítő Kft.
8000, Székesfehérvár, Takarodó út 2
Phone: +36-22-507-472
Fax: +36-22-507-484
www.makita.hu

ROMANIA

Makita Romania S.R.L.
Str. I.C.Bratianu nr. 164 Depozit Faza 3
077030 Comuna Branesti jud. Ilfov
Romania
Phone: +40 21 569 80 61
+40 21 569 80 62
Fax: +40 21 569 80 59
www.makita.ro

SC Makita EU SRL

Str.I.C. Bratianu, nr.164, Comuna
Branesti,
jud. ILFOV, ROMANIA 077030
Phone: +40-21-310-7675
Fax: +40-21- 200-0219

BULGARIA

Makita Bulgaria EOOD
Okolovrasten Pat (circle road), No.373,
Sofia 1186, Bulgaria
Phone: +359-2-921-0551
Fax: +359-2-921-0550
www.makita.bg

RUSSIA

Makita LLC
1, build. 1, Permskaya str. , Moscow,
Russia, 107143
Phone: +7 (495)-915-88-66
Fax: +7 (495) 916 57 31
www.makita.ru

MAKITA LLC, Vladivostok branch

83, 1st RABOCHAYA str. ARTEM 692770,
RUSSIA
Phone: +7(423)202-65-23

MAKITA LLC, Novosibirsk branch

15, Dargomyzhskogo str., Novosibirsk,
Russia, 630047
Phone: +7 (383) 209 18 19
Fax: +7 (383) 209 18 19

MAKITA LLC, St.Petersburg branch

Shpalernaya street 54, letter B, premise
25-H,
Saint Petersburg, Russia, 191015
Phone: +7 (812) 244-47-84

MAKITA LLC, Samara Branch

3 Mirnaya str., Samara, Russia, 443035
Phone: +7 (846) 202 90 50
+7 (846) 202 42 83

MAKITA LLC, Krasnodar branch

32/2, Turgenevskoe, Takhtamukaisky
district, Adygea Republic, Russia,
385132
Phone: +7 (861) 238 24 97

MAKITA LLC, Yekaterinburg Branch

5, pereulok Avtomatik, Yekaterinburg,
Russia, 620049
Phone: +7 (343) 286 00 09

KAZAKHSTAN

Makita Kazakhstan LLP
Kommunalnaya 39, 050016, Almaty,
Kazakhstan
Phone: +7 727 233 0827
Fax: +7 727 382 7921

UNITED ARAB EMIRATES

Makita Gulf FZE
P.O. Box 17133,
Jebel Ali Free Zone, Dubai, UAE
Phone: +971-(0)4-8860-804
Fax: +971-(0)4-8860-805
www.makita.ae

TANZANIA

MAKITA AFRICA LIMITED
P.O. Box 20998,
2nd Floor, Staywell Office Building,
Haile Selassie Road, Masaki, Msasani Peninsula,
Dar es Salaam, Tanzania
Phone: +255 22 2602870

OCEANIA

AUSTRALIA

Makita (Australia) Pty. Ltd.

Head office
2 Litton Close Pemulwuy. NSW. 2145
Phone: +61 1300 361 690
Fax: +61 1300 361 770
www.makita.com.au

Hobart office

374A Kenwick Street Glenorchy, TAS 7010
Phone: +61 1300 361 690
Fax: +61 1300 361 770

Perth office

374A Kenwick Rd Maddington WA 6109
Phone: +61 1300 361 690
Fax: +61 1300 361 770

Factory Service Center

Sydney, Melbourne, Brisbane, Perth,
Hobart

NEW ZEALAND

Makita (New Zealand) Ltd.

Head office
46 Westpoint Drive, Hobsonville,
Auckland 0618
Phone: +64-(0)9-479-8251
Fax: +64-(0)9-479-8259
www.makita.co.nz

Christchurch Office

Unit10, 11, 8 Islington Ave,
Waterloo Park Christchurch
Phone: +64-(0)3-930-0500

Factory Service Center

Auckland, Christchurch

MAKITA AUTHORIZED DISTRIBUTORS IN MIDDLE EAST & AFRICA

BAHRAIN

M.H.AL.MAHROOS BSC (c)
P.O. BOX 65, Manama
Tel.: +973 17408090
Fax: +973 17404323
E-Mail: almahroos@almahroos.com

K.S.A

KHUSHEIM CO. FOR INDUSTRIAL EQPT.
DAMMAM 31411
P.O. BOX 119,
Tel.: +966 3 8333574
Fax: +966 3 8325451
E-Mail: makita@khusheim.com

KUWAIT

ARABI COMPANY W.L.L.
Makita Showroom Canada dry street
PO BOX 4090
Tel.: +965 24714551
Fax: +965 24742566
E-Mail: powertools@arabicompany.net

OMAN

**GULF SERVICES & INDUSTRIAL
SUPPLIES CO. LLC**
RUWI 112
PO BOX 2250
Tel.: +968 24814273
Fax: +968 24816146
E-Mail: cs@arabigsis.com

U.A.E.

NASER AL SAYER & CO. L.L.C.
PO BOX 1825, Dubai
Tel.: +971 4 2222471
Fax: +971 4 2275803
E-Mail: nasco@emirates.net.ae

AFGHANISTAN

SYAH KOH WAL LTD
Hilal-E-Ahmar Market
P.O.Box 1508
3rd Road Of Qowai Markaz Kabul
Tel.: +93 75 2021670
E-Mail: makita.kabul.afg@gmail.com

EGYPT

CHEHAB EGYPT COMPANY
14 Saray Al-Azbakia Street
Cairo, Egypt
Tel.: +202 25903120
Fax : +202 25927400
E-Mail: E-Mail: rehab@chehabegypt.com

IRAQ

AL USOOL GENERAL TRADING CO. LTD
P.O.Box 5508
Baghdad
Tel.: +971 4 3549933
Fax: +971 4 3549944
E-Mail: info@usoolgroup.com

JORDAN

**JORDAN INDUSTRIAL EQUIPMENT
ESTABLISHMENT**
P.O.Box 620624 Amman 11162
Tel.: +962 6 4772815
Fax: +962 6 4772809
E-Mail: info@makita.jo

LEBANON

CHEHAB BROTHERS S.A.L.
Saifi, Najib Houbaika Street, Chehab Bros
Bldg.
POB: 11-3651
1107 2140 Riad El-Solh, Beirut
Tel.: +961 1 566535
Fax: +961 1 562532
E-Mail: samir@chehab-bros.com

YEMEN

CATAH CADAS CO.
P.O.Box 1274
Doha Str., Sana'a
Tel.: +967 7 77 240537
Fax: +967 7 77 243857
E-Mail: cadas@y.net.ye

BURUNDI

BRUNO JAUMAIN
P.O.Box 658 Bujumbura
Tel.: +257 22 229431
Fax: +257 22 211518
E-Mail: bruno.frigo@hotmail.com

DJIBOUTI

ETS. TANI BOULAOS
P. O. Box 2035, Republique De Djibouti
Tel.: +253 21 250980
Fax: +253 21 352333
E-Mail: taniboulaos@intnet.dj

ETHIOPIA

ABDURAHMAN A. SHERIF
PO Box 2147, Merkato near Anwar Mesgid,
Addis Ketema Sub City
Addis Ababa
Tel.: +251 11 2755590
Fax: +251 11 2755122
E-Mail: asherif@ethionet.et

KENYA

INTERCROSS AGENCIES LTD.
Baricho Road, Plot# 33, Behind Toyota
Tel.: +254 20 6531982
Fax: +254 20 6531985
E-Mail: icross@swiftkenya.com

MAURITIUS

ALBERT TRADING LTD
17 Brabant Street, Port Louis, Republic of
Mauritius
Tel.: +230 2080199
Fax: +230 2112404
E-Mail: alberttrading@intnet.mu

RWANDA

Sofaru Limited
KN 1 RD 48, Boulevard De La Nyabugogo
PO Box 3290,
Kigali

Tel.: +250 786 394 551
E-Mail: sofaru10@yahoo.fr

SEYCHELLES

BODCO LTD
Bodco Building
Harbour trading Estate
Port Victoria
P.O.Box 270
Victoria, Mahe
Tel.: +248 4285700, 4285711, 4285712
Fax: +248 4224065
E-Mail: bodco@seychelles.net

TANZANIA

ASAR LTD.
10 India street, P.O. Box 674, Dar Es Salaam
Tel.: +25522 2121656
Fax: +25522 2113931
E-Mail: sales@asar.co.tz

UGANDA

KIBAO INVESTMENTS CO. LIMITED
Plot No : 108, Next to City Tyre,
6th Street, Industrial Area.
P.O.Box : 10356, Kampala - UGANDA (East
Africa)
Tel.: +256 41 4232207, 4286109
Fax: +256 41 4232212, 4343956
E-Mail: kibao@infocom.co.ug

Safety Precautions

When using electric tools, basic safety precautions should always be followed to reduce the risk of fire, electric shock, and personal injury, including the following.

/// KEEP WORK AREA CLEAN.

Cluttered areas and benches invite injuries.

/// CONSIDER WORK AREA ENVIRONMENT.

Don't use power tools in damp or wet locations. Keep work area well lit. Don't expose power tools to rain. Don't use power tool in presence of flammable liquids or gases.

/// KEEP CHILDREN AWAY.

All visitors should be kept away from work area. Don't let visitors touch the tool or extension cord.

/// STORE IDLE TOOLS.

When not in use, tools should be stored in a dry, high of locked up place, out of reach of children.

/// DON'T FORCE THE TOOL.

It will do the job better and safer at the rate for which it was intended.

/// USE THE RIGHT TOOL.

Don't force small tools or attachments to do the job of a heavy-duty tool. Don't use tools for purposes not intended.

/// DRESS PROPERLY.

Don't wear loose clothing or jewelry. They can be caught in moving parts. Rubber gloves and non-skid footwear are recommended when working outdoors. Wear protective hair covering to contain long hair.

/// USE SAFETY GLASSES.

Also use face or dust mask if the cutting operation is dusty.

/// DON'T ABUSE THE CORD.

Never carry the tool by the cord or yank it to disconnect it from the socket. Keep the cord away from heat, oil, and sharp edges.

/// SECURE WORK.

Use clamps or a vise to hold the work. It's safer than using your hand and it frees both hands to operate the tool.

/// DON'T OVERREACH.

Keep proper footing and balance at all times.

/// MAINTAIN TOOLS WITH CARE.

Keep cutting tools sharp and clean for better and safer performance. Follow instructions for lubrication and changing accessories. Inspect tool cord periodically and if damaged, have it repaired by an authorized service facility. Inspect extension cords periodically and replace, if damaged. Keep handles dry, clean and free from oil and grease.

/// DISCONNECT TOOLS.

When not in use, before servicing and when changing accessories such as blades, bits and cutters.

/// REMOVE ADJUSTING KEYS AND WRENCHES.

Form the habit of checking to see that keys and adjusting wrenches are removed from the tool before turning it on.

/// AVOID UNINTENTIONAL STARTING.

Don't carry a plugged-in tool with a finger on the switch. Ensure switch is OFF when plugging in.

/// USE OUTDOOR EXTENSION CORDS.

When tool is used outdoors, use only extension cords intended for outdoor use.

/// STAY ALERT.

Watch what you are doing. Use common sense. Don't operate tool when you are tired.

/// CHECK DAMAGED PARTS.

Before further use of the tool, a guard or other part that is damaged should be carefully checked to determine that it will operate properly and perform its intended function. Check for alignment of moving parts, free running of moving parts, breakage of parts, mounting and any other conditions that may affect its operation. A guard or other part that is damaged should be properly repaired or replaced by an authorized service center unless otherwise indicated in this instruction manual. Have defective switches replaced by an authorized service facility. Don't use the tool if the switch does not turn it on and off.

/// GUARD AGAINST ELECTRIC SHOCK.

Avoid body contact with earthed or grounded surfaces (e.g. pipes, radiators, ranges, refrigerators).

/// REPLACEMENT PARTS.

When servicing a tool, use only identical replacement parts.

/// VOLTAGE WARNING:

Before connecting the tool to a power source (receptacle, outlet, etc.) Be sure the voltage supplied is the same as that specified on the nameplate of the tool. A power source with voltage greater than that specified for the tool can result in SERIOUS INJURY to the user V as well as damage to the tool. If in doubt, DO NOT PLUG IN THE TOOL. Using a power source with voltage less than the nameplate rating is harmful to the motor.

Note

- Makita reserves the right to change specifications of parts and accessories without notice.
- Items of standard equipment and specifications may vary by country or area.
- Net weight and dimensions may differ by the type of battery.
- Standard export color for motor housing is Makita industrial green (blue).
- Please state required voltage when ordering. These offers are subject to availability in each country. Actual product color may differ slightly from color reproduced here.
- Weight data in this catalogue is the value measured by us according to EPTA Procedure.

Guarantee

Every Makita tool is thoroughly inspected and tested before leaving the factory. It is guaranteed against defective workmanship and materials. Should any trouble develop, return the COMPLETE tool prepaid to Makita or point of purchase. If inspection shows trouble is caused by defective workmanship of material, all repairs will be made without charge. The guarantee does not apply where repairs have been made or attempted by others; repairs are due to normal wear; the tool has been abused or in an accident; misuse is evident – caused by overloading the tool beyond its capacity, use of the tool after partial failure or use with improper accessories.