

Makita

2021 GENERAL CATALOGUE (ACCESSORIES)

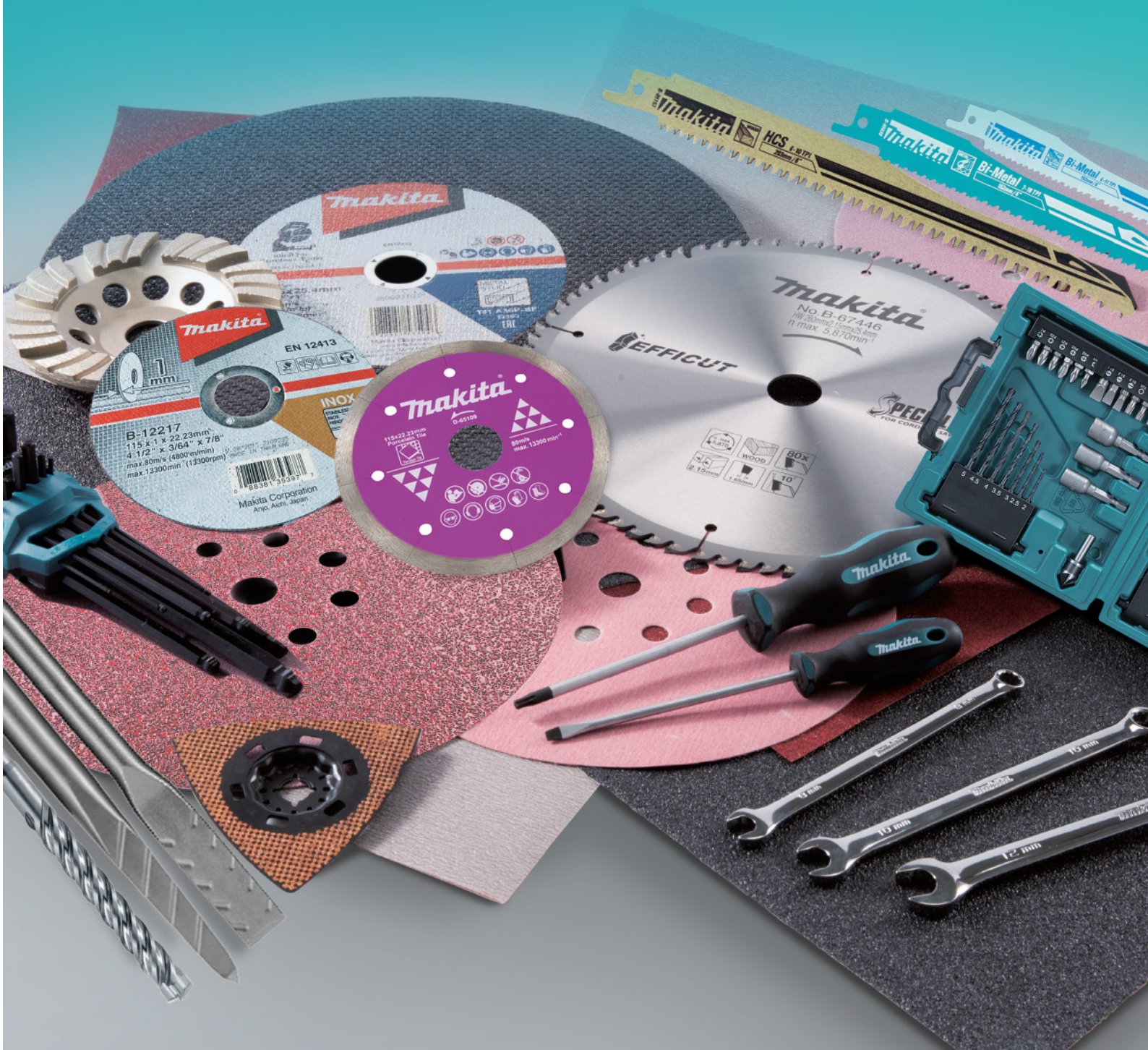

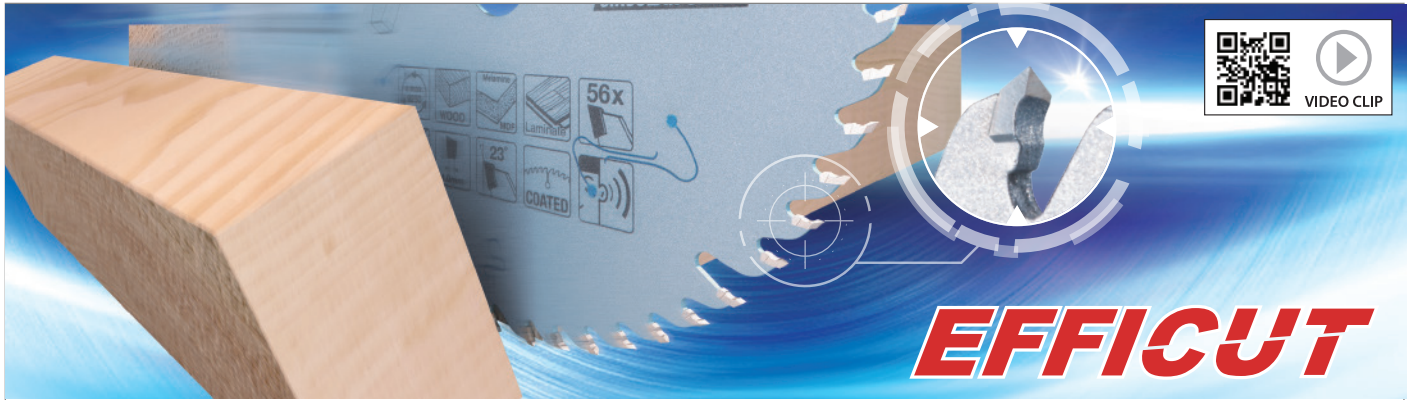

PREMIUM TCT SAW BLADES "EFFICUT" FOR WOOD



EFFICIENT SLIM TIP'S BOTTOM
reduces cutting resistance providing a longer runtime



EFFICIENT CURVED TIP'S BODY
allows excellent chip removal with reduced cutting resistance



EFFICIENT SHARP TIP'S TOP ANGLE
provides clear cutting with little effort

MORE CUTS PER CHARGE



FAST CUTTING



LONGER LIFE



PREMIUM TCT SAW BLADES EFFICUT FOR METAL



STRONG AND LEAST CHIPPING



RELEASE SWARF SMOOTHLY



SUPERIOR IN STRAIGHT CUTTING

MORE CUTS PER CHARGE



FAST CUTTING



LONGER LIFE



DRILLING INTO REINFORCED CONCRETE IS NO LONGER A HIT AND MISS APPLICATION

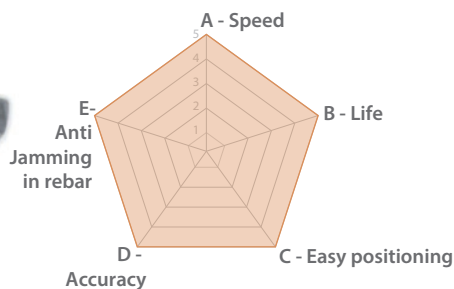

- Its unique symmetrical head geometry ensures precision drill holes.
- Perfect for use in the hardest of natural stone.
- Perfect for critical anchor fixings and where spot drilling is required.
- The Nemesis will drill up to 50% more holes than normal rotary hammer drill bits



INDEX

Makpac Cases	A 008	Hole Saw Material Chart	A 050	Multi Tool Accessories	A 089
Makpac Cases Type 1, 2, 3, 4	A 009	Hole Saw (Standard Range)	A 051	Applications Chart	A 090
Makpac Storage Box	A 009	Hole Saw (Premium Range)	A 052	Starlock	A 093-095
Makpac Cooler Box	A 009	Vacuum Brazed Diamond Hole Saw	A 053	OIS	A 096
Makpac Trolley	A 009	Diamond Wet Hole Saw	A 054	Abrasive Delta Paper	A 097
Makpac Adapter	A 009	Diamond Wet Core Cutters and Accessories	A 054	Diamond [Cutting / Grinding Concrete]	A 099
Batteries, Chargers & Adapters	A 010	Diamond Core Cutter and Accessories	A 055	Diamond Wheels Material Chart	A 100
Batteries	A 014	Broach Cutter and Accessories	A 056	Diamond Wheels - Segmented	A 101
Chargers	A 017	Mixing Blades and Accessories	A 057	Diamond Wheels - Segmented Wave	A 101
Adapters	A 020	Drill Stands and Vise	A 058	Diamond Wheels - Corrugated	A 102
Power Source Kit	A 021	Drill Chucks	A 059	Diamond Wheels - Corrugated Rim	A 102
Battery protectors and Tool Catchers	A 022	Angle Attachments	A 060	Diamond Wheels - Cordless Cutters	A 103
Bulb and Tripod	A 022	DRILL BITS & CHISELS	A 061	Diamond Wheels - Electro Deposited	A 103
Fixing / Fastening Accessories	A 023	[CONCRETE / HAMMER ACCESSORIES]		Diamond Wheels - X-Lock	A 104
Phillips bits	A 024	SDS-PLUS Nemesis Drill Bits - (Premium Range)	A 062	Diamond Wheels - Rescue Force	A 104
Insert Bits	A 026	SDS-PLUS Drill Bits (Standard Range)	A 063	Diamond Wheels - Vacuum Brazed - Rescue	A 104
Slotted Bits	A 026	SDS-PLUS 14 pcs Drill Bits Assortment	A 064	Diamond Wheels - Cordless Power Cutter	A 105
Flexible Shaft Bits	A 026	SDS-PLUS 13 pcs Drill Bits / Chisels Assortment	A 064	Diamond Wheels - Power Cutters / Angle Cutter	A 105
Phillips Magnetic bit holder	A 027	SDS-PLUS 6 pcs Drill Bits / Chisels Assortment	A 064	Diamond Wheels - Cosmos (Quasar)	A 105
Magnetic Bit holder / Magnetic Nut Setter	A 027	SDS-PLUS 5 pcs set Assortment	A 064	Diamond Wheels - Dia-Duran	A 105
Hex to Square Socket Adaptor	A 027	SDS-MAX Drill Bits - 4 Cutter (Premium Range)	A 065	Diamond Wheels - Wall Chaser	A 106
Maklok Chuck	A 027	SDS-MAX Drill Bits - 2 Cutter (Standard Range)	A 066	Offset Diamond Wheels (Cup Wheels)	A 106-107
31pcs Screwdriver Bit Set (in Battery Shape Case)	A 028	Hexagonal Shank (Premium Range)	A 067	Vacuum Brazed Diamond Core Bits	A 108
10pcs Screwdriver Bit Set (in Clamshell)	A 028	Hexagonal Shank (Standard Range)	A 067	Grinding Accessories	A 109
35pcs Impact BLACK Screwbits Set	A 028	Taper Shank / Taper Shank Adapter / Cotter Drift Key)	A 067	Angle Grinder Accessories	A 111-122
Torison Bits	A 029	SDS-MAX Mining Bits	A 068	- X-Lock Wheels	A 111
Socket Bits	A 030	Chisels Application Chart	A 069	- Thin Cutting Wheels	A 112
Locator Assembly	A 030	Self Sharpening Bull Point	A 070	- Cutting Wheels (Depressed Center)	A 113
Autofeed Attachment set	A 031	Premium Chisels	A 070	- Grinding Wheels (Depressed Center)	A 114
Drywall Screw Strip	A 031	Bull Point	A 071	- Flap Disc Series	A 115-117
Extension Handle bar (for Auto feed Screwdrivers)	A 031	Cold Chisels	A 071	- Abrasive Disc / Rubber Pad and Loc nut wrench	A 118
Impact Sockets (for impact wrenches)	A 032	Scaling Chisels	A 072	- Safety Flanges and Super Flanges	A 119
9pcs 1/2" Impact Socket with Socket Adapter Set	A 034	Grooving Chisels	A 072	- Safety Guidelines : Abrasive Wheels	A 120
14pcs 1/2" Drive Deep Impact Socket Bit Set	A 034	Clay Spade	A 073	- Wire Cup Brush	A 121-122
Extension for 1/2" Square Drive Impact Wrench	A 034	Rammer	A 073	Straight Grinder Accessories	A 123
Extension for 1/2" 3/5" 1" Square Drive Impact Wrench	A 035	Bushing Tool	A 074	- Grinding Wheel	A 123
Bit Adapter Assembly	A 035	Scraper Assembly	A 074	Bench Grinder Accessories	A 123
Universal Joint	A 035	Chisel Assortment (3Pcs Set) - SDS-PLUS	A 074	- Grinding Wheel	A 123
1/4" Hex shank screwdriver bits adapter	A 035	Chisel Adapter	A 074	- Eye Shields - Bench Grinders	A 123
Drill Chuck Assembly	A 035	Ratio Quick Core Bit / Extension / SDS-MAX Adapter	A 075	Die Grinder Accessories	A 124-125
Drill Bit Remover Set	A 036	TCT Hollow Core Bit and Accessories	A 075	- Tungsten Carbide Burrs	A 124
Earth Auger Drill Bit with socket and O ring	A 036	TCT Core Bit and Accessories	A 075	- Wheel Point	A 124
Angle Attachments and socket adapter for TL064 / TL065	A 036	Drill Chuck Adapter Assembly (for the slide chuck)	A 076	- Vise Holder	A 124
Socket adapter - WR100D	A 036	Dual Slot Adapter / Ground Rod Adapter	A 077	- Wheel Point	A 124
Grip Assembly	A 036	Quick Change Drill Chuck / Drill Chuck Assembly	A 077	- Collet Cone	A 125
DRILL BITS [WOOD / METAL / MASONRY]	A 037	Dust Extraction System Set (Attachment)	A 077	Stone Grinder Accessories	A 125
Wood Drilling Bits Classification	A 038	Dust Case and Filter	A 078	- Straight Cup Wheel	A 125
Standard 3 Point Wood Bit	A 039	Dust Cup Attachment	A 078	Other Accessories	A 125-128
Auger Bit	A 039	Dust Bag Assembly	A 078	- Dust Cover Attachment	A 125
Spade (Flat) Bit	A 040	Blow Out Bulb and Dust Cap	A 078	- Dust Bag Assembly	A 125
Self Feeding Bit Set	A 041	Grip	A 078	- Dust Collecting Guards	A 126
Forstner Bit Set	A 041	Hammer Trolley	A 078	- Dust Cover Attachment	A 126
Wood Drill Bit for SDS-Plus Hammers	A 041	Hammer Service Kit	A 079	- Wheel Covers	A 127
Glass and Tiles Drill Bit	A 041	Oil Supply and Grease Vessel	A 079	- Grip and Wrenches	A 128
HSS Drill Bits Classification / Material Chart	A 042	CUTTING [METAL]	A 080	Sanding / Polishing Accessories	A 129
HSS-G Metal Drill Bits	A 043	Metal Cutter Accessories (Efficut Saw Blades)	A 081	Abrasive Belt	A 130
19Pcs HSS-G Metal Drill Bit Set (Assorted Size)	A 044	Metal Cutter Accessories (Saw Blades)	A 082	Abrasive Paper	A 131
HSS-G Double Ended Drill Bits	A 044	Metal Cutting Saw Accessories (Saw Blades)	A 083	Abrasive Disc	A 133
HSS Co-Metal Drill Bits	A 045	Saw Blades for Aluminium Composite	A 083	Rubber Pad and Accessories	A 134-135
6pcs HSS Co-Metal Drill Bit Set	A 045	Portable Band Saw Accessories	A 084	Punch Plate	A 135
HSS-Tin Economy Drill Bits	A 046	Portable Cut-off Accessories (Abrasive Wheels)	A 084	Wool Pad / Felt Pad / Sponge Pad	A 136
19pcs HSS-Tin Economy Drill Bits	A 046	Power Cutter Accessories (Abrasive Wheels and Trolley)	A 085	Wheel Sander Accessories	A 136
HSS-Tin Economy Drill Bit with 1/4" Hex Shank	A 047	Thread Rot Cutter / Steel Rod Cutter Accessories	A 085	- Cotton Buff Wheel	A 136
HSS-Tin Drill Bits for SDS-Plus Hammers	A 047	Hole Puncher Accessories	A 086	- Wire Brush Wheel	A 136
HSS-Titanium Coated Drill Bit for 3 Jaw & Maklok Chucks	A 047	Shear and Nibblers Accessories	A 087	- Slit Paper Wheel	A 136
16pcs HSS-Titanium Coated Drill Bit for 3 Jaw Chucks	A 047	Tile Cutter Tool Accessories	A 088	- Nylon Brush Wheel	A 136
Straight Shank Drill Bits / Long Straight Shank Drill Bits	A 048	Wrenches	A 088		
Straight Shank Drill Bit Sets	A 048				

INDEX

Stone Polisher Accessories	A 137	Router / Planer Accessories	A 162	Three Bead Fluting Bit	A 173
Diamond Polishing Pad	A 137	Router Bits (Economy Range)	A 163	Cove & Bead Bit	A 174
Belt sander Accessories	A 137-138	Straight Bit (1 Flute)	A 163	Moulding Bit	A 174
- Sanding Shoe Assembly (For Belt Sander)	A 137	Straight Bit (2 Flute)	A 163	Multi Profile Bit Decorative Bead Bit	A 174
- Clamp Complete (For Belt Sander)	A 137	Flush Trim Bit	A 163	Classical Multi Profile Bit	A 174
- Step (For Belt Sander)	A 137	V Groove Bit	A 163	Multi Profile Bit	A 174
- Carbon Plate (For Belt Sander)	A 138	Round Nose Bit	A 164	Slotting Cutter	A 174
- Cork Rubber Plate (For Belt Sander)	A 138	Panel Pilot Bit	A 164	Variable Slot Cutter Set	A 175
- Steel Plate (For Belt Sander)	A 138	Core Box Bit	A 164	Thumb Mold Bit	A 175
- Stand Set (For Belt Sander)	A 138	Dovetail Bit	A 164	Classic Profile Bit	A 175
- Sanding Arm Assembly (For Belt Sander)	A 138	Classic Plunge Cut Bit	A 164	Traditional Table Edge Bit	A 175
- Belt Sander Stand (For Belt Sander)	A 138	Ovolo Bit	A 164	Classic Ogee Bit	A 175
Other Accessories	A 139	Roundover Bit with Bearing	A 164	Handrail Bit	A 175
- Paper Dust Bag Dust Bag Assembly / Dust Bag Nozzle	A 139	Beading Bit with Bearing	A 164	Decorative Bead Bit	A 176
- Grip / Loop Handle	A 139	Chamfer Bit with Bearing	A 165	Bullnose Mould Bit	A 176
- Wrenches	A 139	Roman Ogee Bit with Bearing	A 165	Decorative Bead Bit	A 176
Sawing Accessories	A 140	Ogee Bit- with Bearing	A 165	Crown Molding Bit	A 176
Blade Tooth Shape / Technical Term	A 141	Keyhole Bit	A 165	Raised Panel Bit-Wavy	A 176
Efficut Saw Blades for Metal	A 143	Reversible Glue Joint Bit (Straight Profile)	A 165	Door Edge Bit	A 176
Efficut saw Blades for Wood	A 143	Tongue & Groove Assembly	A 165	Solid Surface Cutters - Ogee	A 177
Saw Blade For Plunge Cut Circular Saw	A 144	Slotting Cutter - 3 Wing Slot Cutter	A 165	Board-Joining Bit	A 177
Saw Blade For Sandwich Panel	A 144	Slatwall Router Bit	A 165	Economy Tongue & Groove Set	A 177
Circular Saw Blades	A 144	Router Bits	A 166	Hinge Boring bit	A 177
Slide Compound / Miter Saw Blade	A 146	Straight Bit	A 166	Straight Sash Router Bit	A 177
Table Saw Blade	A-146	Drill Point Flush Trimming Bit	A 167	Double Drill Bit	A 178
Thin Kerf Blade	A 146	Flush Trim Bit	A 167	Ball Bearing	A 178
Specialized Tip Saw Blade for Construction	A 147	Bevel Trim Bit	A 167	Router Bit Set 12pc / 4pcs / 3pcs	A 178
"M" Force Blade	A 147	Panel Pilot Bit	A 167	Other Router Accessories	A 179-181
Specialized for MDF Cutting	A 147	Drill Point Double Flush Trimming Bit	A 167	Template Guide / Template Guide 25 / Template Guide 30	A 179
Specialized Blades for Cutting Aluminium	A 148	"V" Groove Bit	A 167	Straight Guide Assembly	A 180
Universal Blades for Cutting Aluminium	A 148	"U" Groove Bit	A 168	Guide Holder Assembly	A 180
T.C.T Saw Blade for Tile Cutter Machine 4100NH	A 148	Core Box Bit	A 168	Trimmer guide Assembly	A 180
Combination Saw Blade (H.S.S)	A 149	Ball Groove Bit	A 168	Guide Rail Adapter Set	A 180
Cross Cut saw Blade (H.S.S)	A 149	Beading Bit	A 168	Collet Sleeve	A 180
Wave Saw Blade	A 149	Cove Beading Bit	A 168	Collet Cone (Collet Chuck)	A 181
Rip Saw Blade	A 149	Ball Bearing Cove Beading Bit	A 169	Trimmer Shoe / Trimmer Base Assembly	A 181
Chisel Tooth Combination Saw Blade (H.S.S)	A 150	Dovetail Bit	A 169	Sash Router Base Assembly	A 181
Arbor and Ring Sizes	A 150	Ogee Bit	A 169	Base assembly for Trimmer (for model RT0700C)	A 181
Jig Saw Blades	A 150-155	Classic Panel Bit	A 169	Planner Blade and Accessories	A 182-184
- Jig Saw Blade Teeth Type and Material	A 151	Classic Beading Bit	A 169	Planer Blade / Mini Planer Blade	A 182
- Makita Type Jig Saw Blade for Wood / Metal	A 152	Pierce & Round Over Bit - Plunge Cutting	A 169	Sharpening Holder Assembly / Dressing Stone	A 182
- B Type Jig Saw Blade For Wood / Metal / Stainless Steel	A 153	Cove & Bead Bit	A 170	Blade Gauge Assembly	A 182
- B Type Saw Blade (Specialized)	A 154	Classical Plunge Bit	A 170	Edge Fence (guide Rule)	A 183
- B Type Jig Saw Blade (Super Express)	A 155	Classic Mold Bit	A 170	Extension Guide Set	A 183
- Jig Saw Blade Assortment	A 155	Rounding Over Bit	A 170	Hood Set	A 183
- Jig Saw blades - D-series	A 155	Ball Bearing Corner Rounding Bit	A 170	Nozzle Assembly	A 183
- Jig Saw for Sanding and Filing	A 155	Slotting Bit	A 171	Planer Stand	A 183
Reciprocating Saw Blade	A 156-157	Roman Ogee Bit	A 171	Triangular Rule	A 183
- Reciprocating Saw Blade for Wood / Metal / Bi-metal	A 156	Ogee Bit	A 171	Magnetic Holder	A 183
- Recipro Saw Blade - Super Express (5pcs and 2pcs set)	A 157	Ogee With Fillet Bit	A 171	Dust Bag Assembly	A 184
Scroll Saw Accessories	A 158	Classic Ogee Bit	A 171	Wrenches	A 184
- Scroll Saw Blade	A 158	Classic Roman Ogee Bit	A 171	Plate Joiner Accessories	A-185
Band Saw Accessories	A 158	Double Ball Bearing Round Corner Bit	A 172	Cutter Blade	A 185
- Band Saw blades	A 158	Double Round Bit	A 172	Cross-Cut Saw Blade	A 185
- Portable Band saw blades	A 158	Cove Bit	A 172	Set Plate and Ange Guide	A 185
Other Accessories	A 159	Chamfering Bit	A 172	Biscuits (1000 pcs set)	A 185
- Table and Stand	A 159	Chamfer Bit	A 172	Wrench and Dust Bag	A 185
- Guide Rail / Clamp Set / Guide Rail Adapter	A 160	Ball Bearing Chamfering Bit	A 172	Cut-out Tool Accessories	A 186
- Guide Rule	A 160	Cavetto Bit	A 173	Drywall Guide Bit	A 186
- Rip Fence Assembly / Vice Assembly	A 160	Wavy Mold Bit	A 173	Circular Guide	A 186
- Blade Clamp Assembly	A 161	Decor Sunk Bead Bit	A 173	Collet Sleeve and Nut and Cone	A 186
- Dust Bag Assembly / Dust Box Set	A 161	Bead & Cove Bit	A 173	Chain Mortiser Accessories	A 186
- Safety Goggles	A 161	Multi Reed Bit	A 173	Cutter Chain and Oil Supply	A 186

INDEX

Cleaner Accessories	A 187		
Cleaner Attachment Charts	A 188	21pcs Pass thru Socket Set	A 223
Hose and Pipes	A 189	14pcs Pass thru Socket Set	A 224
Nozzle assembly	A 190	Locking Flex Pass Thru Handle	A 224
Brushes and nozzles	A 191	Pass Thru Handle Straight	A 224
Cleaning Set	A 192	Pass Thru Socket	A 224
Filters and Dust Bags	A 192	Pass Thru Extension Bar	A 224
Cyclone Attachment	A 194	Socket Adapter	A 224
Battery Adapter for Stick Cleaner	A 194	Ratcheting Tap & die Handle	A 224
Wall Mount Bracket	A 194	Tap Adapter	A 224
AWS adapter	A 194	Twist Lock Die Adapter	A 224
Front Cuffs	A 194	40pcs Ratcheting tap & die set	A 225
Hoses for Dust Collecting	A 195	21pcs Screw Bit & Socket with Ratchet Handle	A 225
Accessories for 406, 407 440	A 196	Ratchet Screwdriver	A 226
High Pressure Washer Accessories	A 196	11pcs Ratchet Screwdriver Pouch with Ratchet Handle	A 226
Heat Gun / Laser Accessories	A 197	Screw drivers	A 226
Heat Gun Nozzles	A 198	Go through screwdrivers	A 226
Laser Accessories	A 199	Shock driver	A 227
Staples / Pin Nails / Brad Nails	A 200	LED Pen Light	A 228
Staples	A 201	10 pcs Bit Se	A 228
Brad Nails	A 202	49 pcs Maklok and 4-way Driver Set	A 228
Pin Nails	A 202	28 pcs Long Life Bit Set	A 228
Garden Tools Accessories	A 203	14 pcs Mini Chuck Set	A 228
Multi Function Power Head Attachments	A 204-205	Maklok Chuck	A 228
Chain saw Accessories	A 206	Screw Guide Set	A 228
Guide bar / Saw Chain / Bar cover	A 207	12 pcs 4-way Driver Set & Pouch	A 229
Rescue Chain and Chain Saw Chain Reels	A 208	17 pcs Maklok Drill and Driver Set	A 229
File and Handle / Screwdriver / Wrench	A 208	20 pcs Quick change Drill and Driver Set	A 229
Test and Diagnostic Tools	A 208	29 pcs Drill Bit, Guide / Driver Set	A 229
Hedge Trimmer/ Shear and Edger Accessories	A 209	Fast Change Countersink Set	A 230
Hedge Trimmer Blade and Blade Cover	A 209	18pcs Metal Drill Bit Set	A 230
Shear Blade	A 209	9pcs Drill Bit Sets	A 230
Chip Reciever	A 210	17 pcs General Purpose Set	A 230
Edger Blade2	A 210	26 pcs Drill Bits and Screwdriver Bits Set	A 230
Brush Cutter Blades (Metal and Plastic)	A 210	32 pcs Maklok Accessory Pouch With Belt Clip	A 231
Trimmer Head Assembly	A 211	Pilot Drill and Grub Screws	A 231
Nylon Cord (String)	A 211	Combination Sets	A 231-239
Nylon Cord (String) Four Leaf	A 212	65pcs Combination Set (For SDS-PLUS Hammers)	A 232
Lawn Mower Blades	A 212	34pcs, 71pcs, 104pcs Maccess Accessories Set	A 233-234
4 Swing Lawn Mower Blade	A 212	103pcs Bit and Hand Tool Display Set (5 Set Pack)	A 234
Blower Accessories	A 213	64 pcs Maklok Quick Change Accessory Set	A 235
Sprayer Accessories	A 214	78 pcs Technician's Fixing Kit	A 235
Oil	A 214	79 pcs Technician's Kit	A 236
Maintenance Kit	A 214	85 pcs Maklok General Purpose Accessory Set	A 236
Hand Tools / Combination Sets	A 215	96 pcs Electronics Kit with Zipper Case	A 237
Tape Measures	A 217	96 pcs Power Drill Accessory Set with Zipper Case	A 237
Tape Measure with Holder & safety lock	A 217	99 pcs Power Tool Accessory Set	A 238
Snap-off Knife	A 217	102 pcs Drill and Screwdriver Set	A 238
Retractable Utility Knife	A 217	138 pcs Power Drilling/Screw Driving Set	A 239
Quick Change Folding Utility Knife	A 217	Others	
Knife Blades Set	A 217	Carbon Brush	A 240
Hammer	A 218		
Flare nut wrench 5pcs. Set	A 218		
Double box wrench 5pcs. Set	A 218		
Pass Thru Adjustable wrench 11pcs set	A 220		
Double ratchet wrench 8pcs Set	A 221		
Combination wrench 9pcs. Set	A 221		
Adjustable wrench	A 221		
Locking adjustable wrench	A 222		
Box joint design Water pump pliers	A 222		
Water pump pliers	A 222		
Hex key set	A 222		
Aviation Snip	A 223		
34pcs 1/4" ratchet & Socket Set	A 223		
23pcs 1/2" ratchet & Socket Set	A 223		

BL4040 - 40v Max Li-ion XGT Battery (4.0Ah)

Adapted to XGT Tools



Pg. A 014

DC40RA - 40v MAX Li-ion XGT Charger

Adapted to XGT Batteries



Pg. A 017

Adapter ADP10

Charging adapter has enabled consumers to charge LXT batteries when using the XGT charger DC40RA



Pg. A 017

BAP18C - Battery Adapter

For 18v LXT Stick Type Cleaners



Pg. A 020

PDC01 - Portable Backpack Power Supply

Backpack utilizes four LXT batteries to provide longer run time for LXT Tools



Pg. A 020

Power Source Kit - XGT

2pcs of BL4040 (4.0Ah) + 1pc DC40RA Charger



Pg. A 021

10pcs Screwdriver Bit Set in Clampshell

The Screwdriver Bit Set can be attached to your waist belt

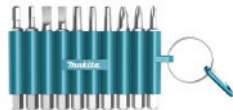

Pg. A 028

35pcs Impact BLACK Screwdriver Bit Set

High durability range for professional use. 10pcs set in counter display box.



Pg. A 028

19pcs HSS-Tin Metal Economy Drill Bits

From sizes 1mm to 10mm 10pcs set in counter display box.



Pg. A 047

Efficut Saw blades for Metal

Increased cutting speed, smoother cuts and more cuts per charge



Pg. A 081

Muti Tool Starlock Blade Set

The components of each set are packed in tool box complete.



Pg. A 095

X-Lock Diamond Wheel

High Durability & High Quality Ideal for Concrete, Granite, Marble



Pg. A 104

Vacuum Based Rescue Diamond Wheel

Used for rescue operation and can cuts various materials.



Pg. A 104

Diamond Wheel For Cordless Power Cutter

High Durability & High Quality Ideal for Stone and Concrete



Pg. A 105

X-Lock Abrasive Wheels

X-Lock Abrasive Cut-Off wheel X-Lock Abrasive Grinding wheel



Pg. A 111

Efficut Saw blades for Wood

Increased cutting speed, smoother cuts and more cuts per charge (for Circular Saw / Slide Compound Miter Saw)



Pg. A 143

Reciprocating Saw Blade Super Express

(2pcs per pack)



Pg. A 157

Folding Miter Saw Stand - WST07

Max extension length: 3,830mm Min length: 1,765 mm



Pg. A 159

Cyclone Cleaner Attachment

Designed to expand the capacity to collect debris.
For Stick Type Cleaners



Pg. A 194

Wall Mount Bracket

Easy Storage with Vacuum Wall Mount Bracket
Get the convenient storage
For Stick Type Cleaners



Pg. A 194

AWS Adapter - WUT02

Enables AC Dust Extractors connect with AWS Tools
For VC3210LX1 / VC3211HX1



Pg. A 194

Attachments for High Power Washers

For Model HW1300 AND HW1200



Pg. A 196

Blower Attachment - UB400MP

For multi function power head
(Powerful Blowing)



Pg. A 205

TCT Saw Blade for Brush Cutter

For Cutting Thick Grass



Pg. A 210

Trimmer head Assembly

Easy to replace nylon thread
without dismantling the trimmer head



Pg. A 211

Rotary Lawn Mower 4 Swing Blade

Provides a clean and efficient cut
for Cordless Lawn Mower DLM531 / 32 / 33



Pg. A 212

Snap-off Knife

Suitable for DIY user, repair shop, interior
decoration



Pg. A 216

Screwdrivers - Go Through Type

Go-Through construction provides greater
striking force than traditional cap ends



Pg. A 226

MAKPAC Cases

Cooler Box, Storage Cases, Makpac Trolley



MAKPAC

MAKPAC is the cases can be stacked on top of each other and locked together with the locking latches. The interconnected cases take up less storage space and are easy to transport to and from the work site. Strong and collapsible carry handles make the cases easy to move and store while the rounded grips make it easy to remove the individual cases.

MAKPAC CONNECTOR CASE

Innovative stackable case design for efficient organization, transporting and protection of tools
Can be stacked on top of any Makpack cases with the locking latches.

The **MAKPAC** connector case system consists of four cases varying in height.

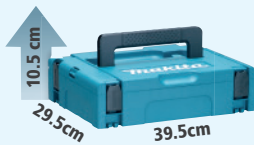

CASE TYPE 1

Part No.: 821549-5



CASE TYPE 2

Part No.: 821550-0



CASE TYPE 3

Part No.: 821551-8



CASE TYPE 4

Part No.: 142729-3

CASE TYPE 4

Part No.: 821552-6

MAKPAC STORAGE BOX

For to carry hand tools and accessories
Can be stacked on top of any Makpac cases with the locking latches.

Part No.: P-84137



MAKPAC COOL BOX



Cool box is a great chilling bin for summer groceries, drinks and ice. Ideal For: Jobsite, Travel, Camping, Sports & Recreation Use

The **MAKPAC** cool box system consists of two cases varying in height.



11L

500mL × 10 2L × 2

CASE TYPE 3

Part No.: 198254-2



18L

500mL × 20 2L × 4

CASE TYPE 4

Part No.: 198253-4

MAKPAC TROLLEY



The Makita MakPack Folding Trolley offers quick and easy transport of a stack of Makita MakPac cases. The maximum load of 125kg is more than enough to cope with a stack of power tools. A webbing belt secures the load to the trolley for safety. The handle is telescopic allowing you to select the most convenient height for comfortably moving the load around.

Part No.: TR00000002



Makpac ADAPTER SET

Makpac adapter set to connects with Makita Vacuum Cleaner

Suits only with Vacuum Model No.

VC3210LX1

VC3211HX1



Part No.: 198730-6

Battery / Chargers / Adapters



XGT is a new system with its own tools, batteries, and chargers. A combination of innovative tool design and higher output batteries provides a genuine solution for high demand industrial users

XGT

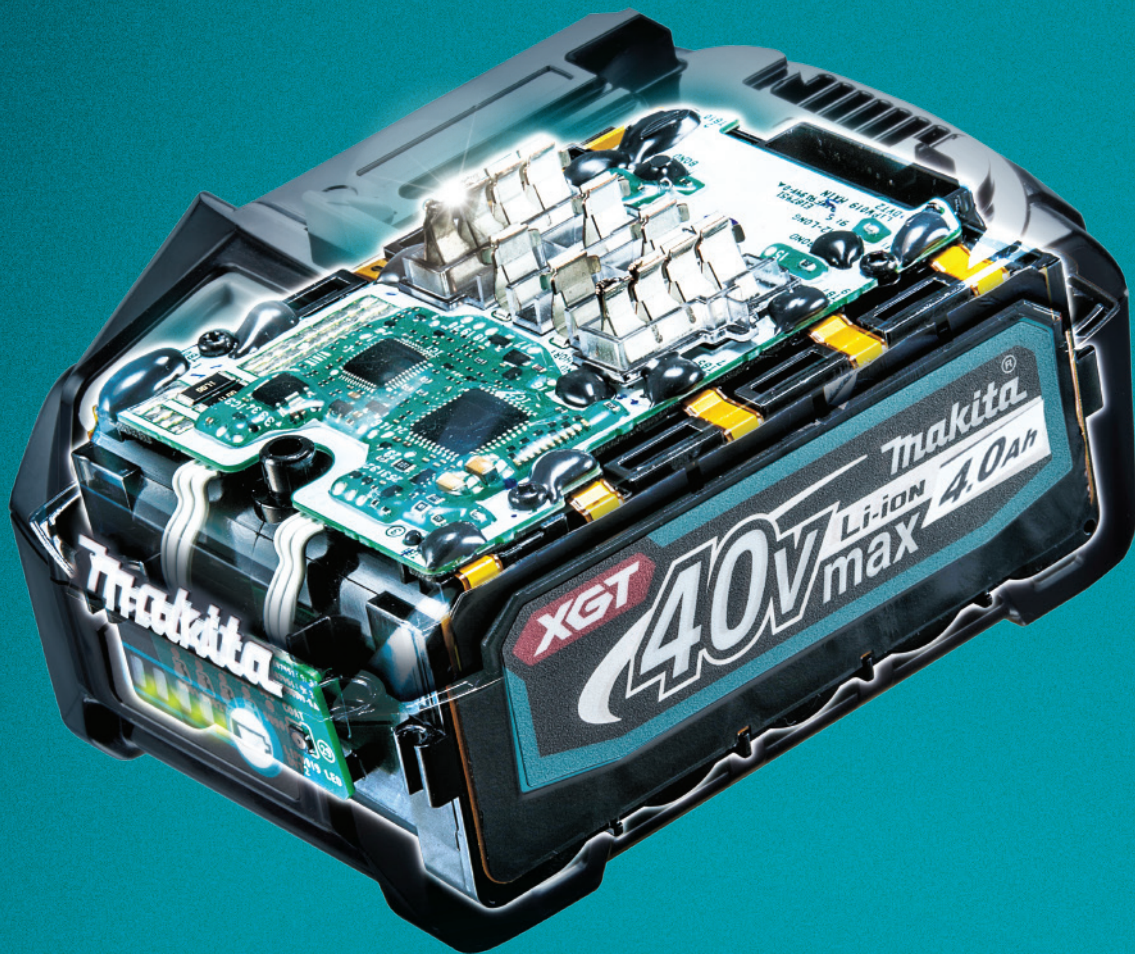

XGT
40V **Li-ion**
max

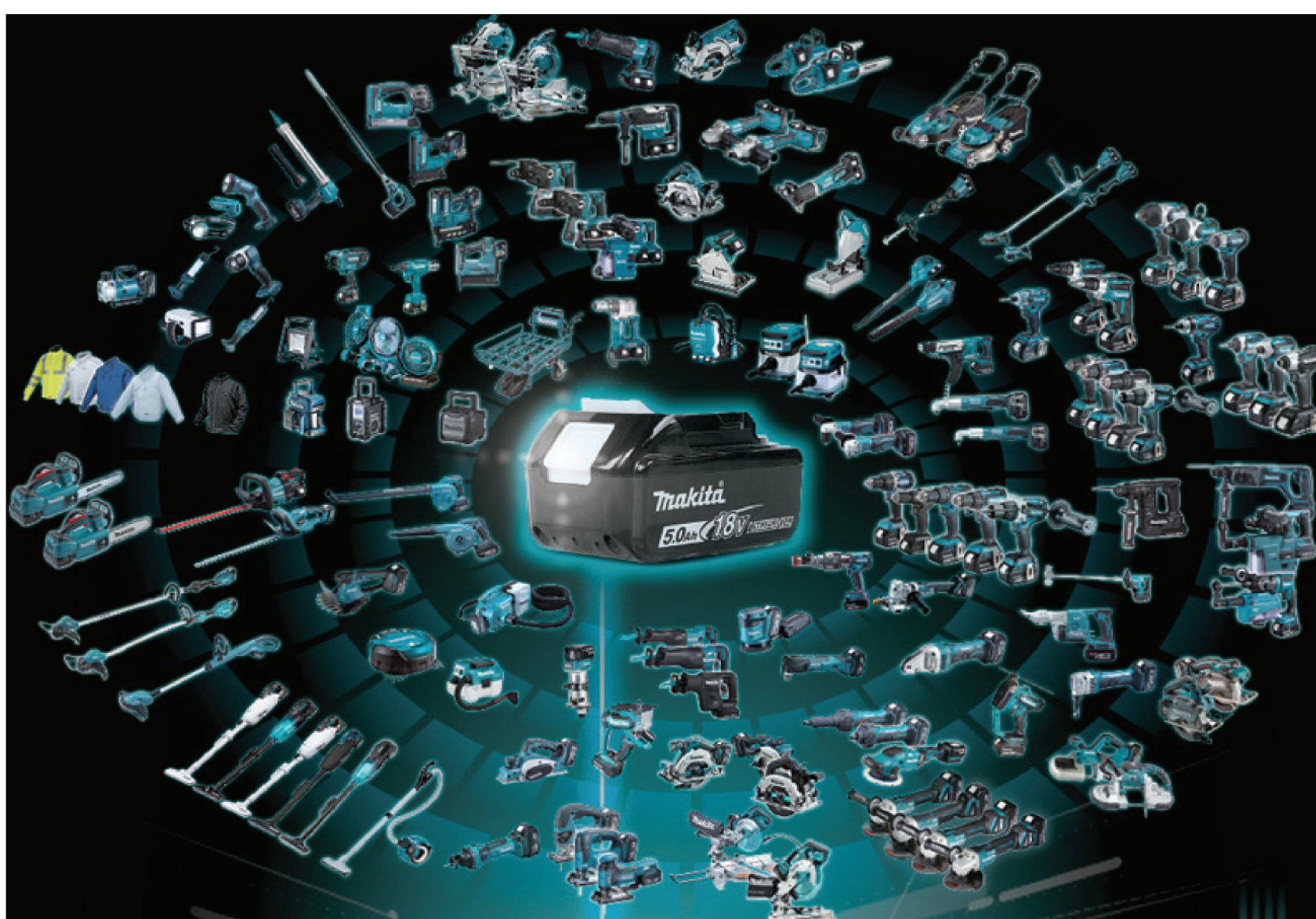

ADP10
**CHARGING
ADAPTER**



DC40RA
CHARGER

Makita

DC40RA



Li-Ion 40Vmax

XGT





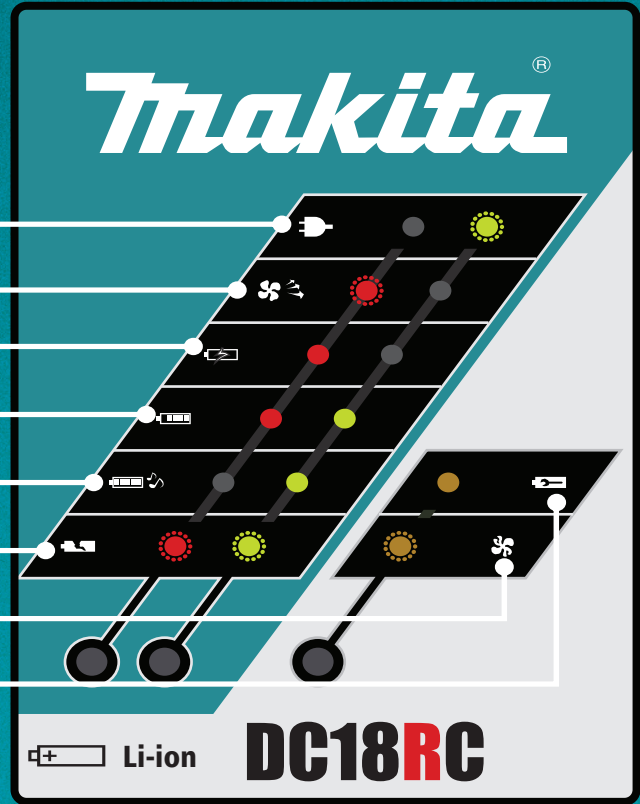

LITHIUM-ION BATTERY CHARGER FUNCTIONS

- Ready to Charge
- Delay Charge (Battery cooling or too cold battery)
- Charging (Below 50% charged)
- Charging (Above 70% charged)
- Charging Complete
- Defective Battery
- Cooling Abnormality
- Conditioning

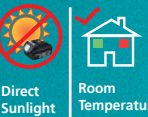

LITHIUM-ION BATTERY USAGE

-  **100%** ▶ Always charge battery to its maximum capacity.
-  ▶ Recharge battery as soon as there is a drop in performance. Do not run down battery to a critical level.
-  ▶ Avoid serious excessive force while operating cordless tools as this demands high amperages from the batteries causing them to overheat.
-  ▶ Discard batteries in a safe way.
-  ▶ Ambient temperature for charging 23°C - 32°C.
-  ▶ Store batteries in a cool, dry place below 40°C and away from the direct sunlight.

BATTERY / CHARGERS

FIXING FASTENING (SCREWDRIVER BITS / IMPACT SOCKETS)

DRILLING (WOOD / METAL / MASONRY)

DRILLING / DEMOLITION (CONCRETE)

CUTTING (METAL)

MULTI TOOL ACCESSORIES

DIAMOND (CUTTING / GRINDING)

GRINDING ACCESSORIES

SANDING / POLISHING ACCESSORIES

SAWING ACCESSORIES

ROUTERS / PLANERS ACCESSORIES

CLEANERS ACCESSORIES

HEAT GUN / LASERS ACCESSORIES

BRAD NAILS / PINS STAPLER

GARDEN TOOLS ACCESSORIES

HAND TOOLS / COMBINATION SETS

Lithium-ion Batteries

40V MAX XGT Lithium-ion Battery (4.0 Ah)



Battery ID	Type	Voltage	Ah	Fuel Gauge	Package	Part no
BL4040	Li-ion	40V max	4.0 Ah	✓	Single	191B26-6

Lithium-ion Battery 18V (6.0 Ah)



Battery ID	Type	Voltage	Ah	Fuel Gauge	Package	Part no
BL1860B	Li-ion	18v	6.0 Ah	✓	Single	197422-4

Lithium-ion Battery 18V (5.0 Ah)



Battery ID	Type	Voltage	Ah	Fuel Gauge	Package	Part no
BL1850B	Li-ion	18v	5.0 Ah	✓	Single	197280-8

Lithium-ion Battery 18V (3.0 Ah)



Battery ID	Type	Voltage	Ah	Fuel Gauge	Package	Part no
BL1830B	Li-ion	18v	3.0 Ah	✓	Single	197599-5

Lithium-ion Battery 18V (1.5 Ah)



Battery ID	Type	Voltage	Ah	Fuel Gauge	Package	Part no
BL1815N	Li-ion	18v	1.5 Ah	x	Bulk	632A54-1

Lithium-ion Battery 18V (1.3 Ah)



Battery ID	Type	Voltage	Ah	Fuel Gauge	Package	Part no
BL1815	Li-ion	18v	1.3 Ah	x	Single	195445-6

Lithium-ion Battery 14.4V (3.0 Ah)



Battery ID	Type	Voltage	Ah	Fuel Gauge	Package	Part no
BL1430B	Li-ion	14.4v	3.0 Ah	✓	Single	197615-3

Lithium-ion Battery 14.4V (1.5 Ah)



Battery ID	Type	Voltage	Ah	Fuel Gauge	Package	Part no
BL1415NA	Li-ion	14.4v	1.5 Ah	✓	Single	196280-5

Lithium-ion Battery 12V MAX CXT (Slide Battery)



Battery ID	Type	Voltage	Ah	Fuel Gauge	Package	Part no
BL1041B	Li-ion	12V	4.0 Ah	✓	Single	197406-2
BL1021B	Li-ion	12V	2.0 Ah	✓	Single	197396-9

Lithium-ion Battery 10.8V (1.3 Ah) (Stick battery)



Battery ID	Battery Ah	Type	Voltage	Part no
BL1013	1.3 Ah	Li-ion	10.8 V	196066-7

Lithium-ion Battery 7.2V (1.5Ah) (1.0Ah) (Stick battery)



Battery ID	Battery Ah	Type	Voltage	Part no
BL7015	1.5 Ah	Li-ion	7.2 V	198000-3
BL7010	1.0 Ah	Li-ion	7.2 V	194355-4

In-built batteries



For Model	Voltage	Ah	Type	Part no
CL105DWX	10.8v	1.3 Ah	Li-ion	632D82-4
DF001DW	3.6v	1.3 Ah	Li-ion	620693-3 comes with controller

Lithium-ion Battery 36V (12.0 Ah)



Battery ID	Battery Ah	Type	Voltage	Part no
BL36120A	12.0 Ah	Li-ion	36 V	BL36120A

Lithium-ion Battery 36V (2.6 Ah)



Battery ID	Battery Ah	Type	Voltage	Part no
BL3626	2.6 Ah	Li-ion	36 V	194873-2

G-Series Lithium-Ion Battery 18V (1.5 Ah)



Battery ID	Battery Ah	Type	Voltage	Part no
BL1815G	1.5 Ah	Li-ion G Series	18V	198186-3

G-Series Lithium-Ion Battery 14.4V (1.5 Ah)



Battery ID	Battery Ah	Type	Voltage	Part no
BL1415G	1.5 Ah	Li-ion G Series	14.4V	198192-8

BATTERY / CHARGERS

FIXING FASTENING (SCREWDRIVER BITS / IMPACT SOCKETS)

DRILLING (WOOD / METAL / MASONRY)

DRILLING / DEMOLITION (CONCRETE)

CUTTING (METAL)

MULTI TOOL ACCESSORIES

DIAMOND (CUTTING / GRINDING)

GRINDING ACCESSORIES

SANDING / POLISHING ACCESSORIES

SAWING ACCESSORIES

ROUTERS / PLANERS ACCESSORIES

CLEANERS ACCESSORIES

HEAT GUN / LASERS ACCESSORIES

BRAD NAILS / PINS STAPLER

GARDEN TOOLS ACCESSORIES

HAND TOOLS / COMBINATION SETS

BATTERY / CHARGERS

FIXING FASTENING (SCREWDRIVER BITS / IMPACT SOCKETS)

DRILLING (WOOD / METAL/ MASONRY)

DRILLING / DEMOLITION (CONCRETE)

CUTTING [METAL]

MULTI TOOL ACCESSORIES

DIAMOND [CUTTING / GRINDING]

GRINDING ACCESSORIES

SANDING / POLISHING ACCESSORIES

SAWING ACCESSORIES

ROUTERS / PLANERS ACCESSORIES

CLEANERS ACCESSORIES

HEAT GUN / LASERS ACCESSORIES

BRAD NAILS/ PINS STAPLER

GARDEN TOOLS ACCESSORIES

HAND TOOLS / COMBINATION SETS

Ni-Mh Batteries

18V Ni-Mh Battery



Battery ID	Battery Ah	Type	Voltage	Partno
1835	2.8 Ah	Cluster	18 V	193061-8

14.4V Ni-Mh Battery



Battery ID	Battery Ah	Type	Voltage	Partno
1435	2.8 Ah	Cluster	14.4 V	193060-0

9.6V Ni-Mh Battery



Battery ID	Battery Ah	Type	Voltage	Partno
9135	2.8 Ah	Cluster	9.6 V	193058-7

12V Ni-Mh Battery



Battery ID	Battery Ah	Type	Voltage	Partno
1235	3.0 Ah	Cluster	12 V	193059-5

Ni-Cd Stick Battery (9.6 V and 7.2 V)

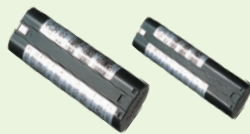

Battery ID	Battery Ah	Type	Voltage	Partno
7000	1.3 Ah	Stick	7.2 V	191679-9
9000	1.3 Ah	Stick	9.6 V	191681-2

Other Batteries



For Model	Battery Ah	Partno
6723DW	1.2Ah	TP00000164

DC40RA 40V MAX XGT Single Port Fast Charger



FAST CHARGING

The tough 40V Max design is supported by a charging system that charges batteries in 45minutes (XGT 40V Max battery BL4040 - 4.0Ah)

Battery Type	Battery Range	Voltage	Plug Pin Type	Part no
Li-ion	40V MAX	110-120	2	191E05-2
		220-240	2	191E13-3
		220-240	3	191E14-1

ADP10 **NEW**

Charging adapter has enabled consumers to charge LXT batteries when using the XGT charger DC40RA

Battery Type	Battery Range	Part no
Li-ion	18V LXT Batteries	191C11-5

DC18RC Single Port Fast Charger



- Very fast, 22 minute charge with audible warning when charging is completed. Makstar charging technology is designed to maximise the life cycle and work volume of every Makstar battery.
- Optimum Charging system with active current control, active thermal control and active voltage control; 2 way communication with battery via cpu chips.
- Can also charge Ni-Cd batteries 7.2V 9.6V, 12V, 14.4V, 18V if using the optional accessory adaptor available.

Battery Type	Battery Range	Voltage	Plug Pin Type	Part no
Li-ion	14.4V - 18V	110-120	2	195582-6
		220-240	2	195584-2
		220-240	3	197378-1

DC18RD Dual Port Fast Charger

Charges two batteries simultaneously, giving tool users unparalleled charging efficiency so their batteries spend more time working and less time sitting on the charger. For added convenience, the DC18RD has a USB port for charging compatible electronic devices.



Other Features:-

- LED charging display.
- Forced cooling system
- Electronic current limiter for overload protection.
- A USB port that provides 1.5A output for charging smart phones, tablets, etc.
- The charger communicates with the individual cell in battery with a built in CPU and then it controls current, voltage, and temperature for both rapid and optimum charge. Therefore the battery has longer life as it can be charged in the best method and duration.



Battery Type	Battery Range	Voltage	Plug Pin Type	Part no
Li-ion	14.4V - 18V	110-120	3	*196929-7
		220-240	2	196933-6
		220-240	3	196940-9

*IN FUTURE IT WILL BE AVAILABLE IN 2 PIN ONLY

DC18SF Four Port Standard Charger

Will accommodate up to four LXT Lithium-Ion batteries. It has two controller that directs charging energy to the battery and with two controllers the Makita 4-port charger is more efficient for faster charging (see charge times below):



Other Features:-

- Easy to see charging display.
- Compact design for easy to hold under arm
- Can be fastened to the wall with four screws.
- The charger communicates with the individual cell in battery with a built in CPU and then it controls current, voltage, and temperature for both rapid and optimum charge. Therefore the battery has longer life as it can be charged in the best method and duration.

Battery Type	Battery Range	Voltage	Plug Pin Type	Part no
Li-ion	14.4V -18V	220-240	3	196427-1

BATTERY / CHARGERS

FIXING FASTENING (SCREWDRIVER BITS / IMPACT SOCKETS)

DRILLING (WOOD / METAL/ MASONRY)

DRILLING / DEMOLITION [CONCRETE]

CUTTING [METAL]

MULTI TOOL ACCESSORIES

DIAMOND [CUTTING / GRINDING]

GRINDING ACCESSORIES

SANDING / POLISHING ACCESSORIES

SAWING ACCESSORIES

ROUTERS / PLANERS ACCESSORIES

CLEANERS ACCESSORIES

HEAT GUN / LASERS ACCESSORIES

BRAD NAILS/ PINS STAPLER

GARDEN TOOLS ACCESSORIES

HAND TOOLS / COMBINATION SETS

BATTERY / CHARGERS

FIXING FASTENING (SCREWDRIVER BITS / IMPACT SOCKETS)

DRILLING (WOOD / METAL/ MASONRY)

DRILLING / DEMOLITION (CONCRETE)

CUTTING (METAL)

MULTI TOOL ACCESSORIES

DIAMOND (CUTTING / GRINDING)

GRINDING ACCESSORIES

SANDING / POLISHING ACCESSORIES

SAWING ACCESSORIES

ROUTERS / PLANERS ACCESSORIES

CLEANERS ACCESSORIES

HEAT GUN / LASERS ACCESSORIES

BRAD NAILS/ PINS STAPLER

GARDEN TOOLS ACCESSORIES

HAND TOOLS / COMBINATION SETS

DC18RE

Two Port Charger (LXT + CXT Fast charger)

18V-14.4V + 12V MAX / 10.8V Li-Ion CXT



- Ability to charge both 18V LXT, 14.4V LXT and 12V MAX CXT battery platforms
- Fast charging - charges 18V Li-Ion 3.0Ah battery in only 22 minutes
- Built-in CPU - gathers information from the battery's memory chip to determine optimum charging method
- Forced air cooling fan - cools the battery to minimise charging time
- LED power display identifies the condition of the battery and charging condition

Battery Type	Battery Range	Voltage	Plug Pin Type	Part no
Li-ion	LXT: 18V-14.4V	110-120	2	198443-9
		220-240	2	198575-2
	CXT: 12VMAX	220-240	3	198447-1

DC18SE

Rapid Automotive Charger

Now you can charge your Makita 18v / 14.4v LXT Lithium-Ion batteries while driving. This new charger is compatible with 12V/ 24V DC cigarette lighter socket available in car, truck and boat.



This Charger will also be perfect for mobile utility and maintenance crews

Battery Type	Battery Range	Type	Part no
Li-ion	14.4V -18V	12V / DC cigarette light socket	194621-9

DC10SB

12V MAX / 10.8V Li-Ion CXT Fast Charger



Battery Type	Battery Range	Voltage	Plug Pin Type	Part no
Li-ion CXT	12V MAX - 10.8V	110-120	2	197435-5
		220-240	2	198576-0
		220-240	3	198433-2

DC36RA

- 22 minute charge for a 36V Lithium-ion Battery



Battery Type	Battery Range	Voltage	Plug Pin Type	Part no
Li-ion	36 V	127	2	194869-3
		220-240	3	194864-3

DC10WA

- Robust fast charger for 10.8v tools.
- Application: Cordless, 10.8 volt, batteries, charging



Battery Type	Battery Range	Voltage	Plug Pin Type	Part no
Li-ion	7.2-10.8 V	220-240	2	630584-0
Li-ion	7.2-10.8 V	220-240	3	630585-0

DC07SA

- Robust fast charger for 7.2v tools.
- Application: Cordless, 7.2 volt, batteries, charging



Battery Type	Battery Range	Voltage	Plug Pin Type	Part no
Li-ion	7.2 V	220-240	2	194320-3

DC18WA

- G Series Li-Ion Battery Charger
- 18V and 14.4V



Battery Type	Battery Range	Voltage	Plug Pin Type	Part no
G series Li-Ion	18V - 14.4V	127V	2	197812-1
		220-240	2	195423-6
		220-240	3	197130-7

DC1439 (Fast Charger)

- Fast charger for Ni-Cd batteries
- 9 - 15 minute charger for a wide variety of Makita Ni-CD Batteries



Battery Type	Battery Range	Voltage	Plug Pin Type	Part no
Ni-Cd	7.2V - 18V	220 - 240	2	192935-0

DC24SA

- Charge Ni-Cd batteries if using the optional accessory adaptor available below



Battery Type	Battery Range	Voltage	Plug Pin Type	Part no
NI-MH	7.2V 9.6V 12V 14.4V	220-240	2	194164-1
	18V 24V	220-240	3	194165-9

Interchangeable adapter ADP04 193947-6 (optional accessory).
Charger works only with the help of this adapter to recharge the NI-CD battery.



Automatic Refreshing Adapter ADP03 193682-6 (optional accessory).
Charger can work with this adapter to refresh NI-CD batteries .



DC1804

- Charger for Ni-Cd batteries.
- 30 and 45 charger for a wide variety of Makita Ni-CD Batteries



Battery Type	Battery Range	Voltage	Plug Pin Type	Part no
Ni-Cd	7.2V - 18V	127	-	193848-8
		220 - 240	2	193827-6
		220 - 240	3	197380-4

DC1414

- Charger for Ni-Cd batteries.
- 30 and 45 minutes charge for a wide variety of Makita Batteries



Battery Type	Battery Range	Voltage	Plug Pin Type	Part no
Ni-Cd	7.2V - 18V	220 - 240	2	193864-0

Refreshing adaptor

- Battery conditioning, refresh your batteries
- Automatic Refreshing.



Type	Part no
For DC18RC / DC24SA Chargers	193682-6

Interchangeable adapter (Converter)

- Converts slide battery charger into cluster type



Type	Part no
For DC18RC / DC24SA Chargers	193206-8
	193947-6

Wireless unit (Bluetooth chip)

- for AWS machines



MODEL	Part no
WUT01	198900-7

Adapters



For Model	Charging Time	Voltage	Plug Pin Type	Part No.
4072D (Cordless Vacuum Cleaner 7.2V)	3hrs	220	2	192737-4
	3hrs	240	3	192739-0
DF001DW (Cordless Screwdriver li-ion 3.6V) Adapter model - ADP07	3-5hrs	-	2	198363-7
			3	198369-5
DC1001 charger for CL105DWX (Cordless Cleaner Li-Ion 10.8V)	3hrs AC only	-	-	196990-4
BMR100	-	-	-	SE00000078
BCF201	-	-	3	TE00000173
DCF102 / CF101D	-	-	-	TE00000213
CF100D	-	-	-	TE00000211

BATTERY / CHARGERS

FIXING FASTENING (SCREWDRIVER BITS / IMPACT SOCKETS)

DRILLING (WOOD / METAL/ MASONRY)

DRILLING / DEMOLITION [CONCRETE]

CUTTING [METAL]

MULTI TOOL ACCESSORIES

DIAMOND [CUTTING / GRINDING]

GRINDING ACCESSORIES

SANDING / POLISHING ACCESSORIES

SAWING ACCESSORIES

ROUTERS / PLANERS ACCESSORIES

CLEANERS ACCESSORIES

HEAT GUN / LASERS ACCESSORIES

BRAD NAILS/ PINS STAPLER

GARDEN TOOLS ACCESSORIES

HAND TOOLS / COMBINATION SETS

BATTERY / CHARGERS

FIXING FASTENING (SCREWDRIVER BITS / IMPACT SOCKETS)

DRILLING (WOOD / METAL / MASONRY)

DRILLING / DEMOLITION (CONCRETE)

CUTTING [METAL]

DIAMOND

GRINDING ACCESSORIES

SANDING / POLISHING ACCESSORIES

SAWING ACCESSORIES

ROUTERS / PLANERS ACCESSORIES

CLEANERS ACCESSORIES

HEAT GUN / LASERS ACCESSORIES

BRAD NAILS/ PINS STAPLER

GARDEN TOOLS ACCESSORIES

HAND TOOLS / COMBINATION SETS

Battery Adapters

Enables to separate the battery from the tool to reduce the tool weight for less hand and arm fatigue.

BAP182



Type	For Model	Part no
BAP182	18+18V Li-ion	197581-4



For Model	Part no
18+18V Li-ion	197727-2

BAP36N



Type	For Model	Part no
BAP36N	36V Model	195311-7

BAP36N is not applicable for Brushcutter BBC300LRD

BCV01



Type	For Model	Part no
BCV01	36V Li-ion	195511-9

BAP18C

Specially designed for use with 18V LXT cordless cleaners
Transfers the battery weight from the cleaner to user's waist to reduce the stress on hand



Type	For Model	Part no
BAP18C	18V LXT (Stick Cleaners)	191M50-5

PDC01

Portable Backpack Power Pack (Compatible with LXT Li-ion Tools)



Backpack utilizes four Lithium-Ion batteries to provide longer run time for 18V LXT and 18V18+V LXT tools

- 2 times the runtime with 18Vx2 tools
- 4 times the runtime with 18V tools

Connector cord

Compatible with 18V+ 18V adapter (Standard)

18V adapter (Sold Separately)



Specification

Voltage	18V
Compatibility	For 18V LXT / 18V LXT x 2 (36V) tools
Battery Fuel Gauge	Yes (indicator for each battery)
USB port	NO
Main power switch with auto-off function	YES
Length of cable	1.7m (Cable to tool)
Dimensions (LxWxH)	400x195x132mm
Net weight (with 4 pcs. of BL1860B)	Battery box: 5.5kg Battery box with Harness: 7.0kg

Available Variants

TYPE	VARIANTS	BATTERIES	CHARGER	ADPATER	CARRY CASE
W/O BATTERY/ CHARGER	PDC01 (191A67-6)	0	0	18V + 18V Adapter	-

Accessories

18V + 18V Adapter

Part No. 191J51-5

(Standard)



18V Adapter

Part No. 191J50-7 (Optional)



Power Source Kit

A combination of Makita 18V Li-ion Batteries and Charger in a Makpac connector case with moulded inlay. Makita owns the world's largest cordless tool line-up in 18V Li-ion tools and offer them in different variants i.e. 6.0Ah, 5.0Ah, 3.0Ah. Tools are also offered without battery & charger. Now pick up the Makita Power source kit, then purchase the 18V "bare tools" and you get the job done. It's an ideal way to start building a Makita cordless tool line-up. Users who preowned "Tool only version" (i.e. Tool without battery and charger) can benefit with this power source kits.

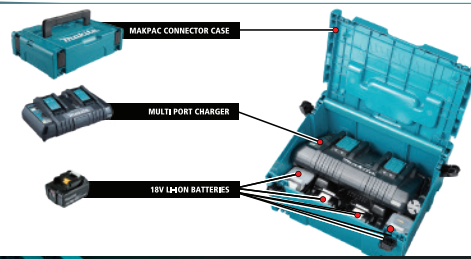

XGT (With 40V MAX - 4.0Ah Battery x 2pcs)

Part no	SET CONTENTS										
	BATTERY					CHARGER					MAKPAC CASE
	MODEL	VOLTS	AMPERE	FUEL GAUGE	QTY	MODEL	VOLTS	PORT	PIN	QTY	
191K03-2	BL4040	40 MAX	4.0Ah	✓	2pcs	DC40RA	40 MAX L-ION	1	3	1pc	Type 1

LXT (With 6.0Ah Battery x 2pcs)

Part no	SET CONTENTS										
	BATTERY					CHARGER					MAKPAC CASE
	MODEL	VOLTS	AMPERE	FUEL GAUGE	QTY	MODEL	VOLTS	PORT	PIN	QTY	
198082-5	BL1860B	18V Li-ion	6.0Ah	✓	2pcs	DC18RD	14.4V - 18V Li-ion	2	3	1pc	Type 3

LXT (With 6.0Ah Battery x 1pc)

Part no	SET CONTENTS										
	BATTERY					CHARGER					MAKPAC CASE
	MODEL	VOLTS	AMPERE	FUEL GAUGE	QTY	MODEL	VOLTS	PORT	PIN	QTY	
198108-3	BL1860B	18V Li-ion	6.0Ah	✓	1pc	DC18RC	14.4V - 18V Li-ion	1	3	1pc	Type 1

LXT (With 5.0Ah Battery x 4pcs)

Part no	SET CONTENTS										
	BATTERY					CHARGER					MAKPAC CASE
	MODEL	VOLTS	AMPERE	FUEL GAUGE	QTY	MODEL	VOLTS	PORT	PIN	QTY	
198568-9	BL1850B	18V Li-ion	5.0Ah	✓	4pcs	DC18RD	14.4V - 18V Li-ion	2	3	1pc	Type 3
197626-8	BL1850B	18V Li-ion	5.0Ah	✓	4pcs	DC18RD	14.4V - 18V Li-ion	2	2	1pc	Type 3

LXT (With 5.0Ah Battery x 2pcs)

Part no	SET CONTENTS										
	BATTERY					CHARGER					MAKPAC CASE
	MODEL	VOLTS	AMPERE	FUEL GAUGE	QTY	MODEL	VOLTS	PORT	PIN	QTY	
198567-1	BL1850B	18V Li-ion	5.0Ah	✓	2pcs	DC18RD	14.4V - 18V Li-ion	2	3	1pc	Type 3
197629-2	BL1850B	18V Li-ion	5.0Ah	✓	2pcs	DC18RD	14.4V - 18V Li-ion	2	2	1pc	Type 3

LXT (With 3.0Ah Battery x 4pcs)

Part no	SET CONTENTS										
	BATTERY					CHARGER					MAKPAC CASE
	MODEL	VOLTS	AMPERE	FUEL GAUGE	QTY	MODEL	VOLTS	PORT	PIN	QTY	
197972-9	BL1830B	18V Li-ion	3.0Ah	✓	4pcs	DC18RD	14.4V - 18V Li-ion	2	3	1pc	Type 3

LXT (With 3.0Ah Battery x 1pc)

Part no	SET CONTENTS										
	BATTERY					CHARGER					MAKPAC CASE
	MODEL	VOLTS	AMPERE	FUEL GAUGE	QTY	MODEL	VOLTS	PORT	PIN	QTY	
191A26-0	BL1830B	18V Li-ion	3.0Ah	✓	1pc	DC18RC	14.4V - 18V Li-ion	1	3	1pc	Type 1

LXT/CXT (With 4.0Ah CXT Battery x 1pc and 5.0Ah LXT Battery x 1pc)

Part no	SET CONTENTS										
	BATTERY					CHARGER					MAKPAC CASE
	MODEL	VOLTS	AMPERE	FUEL GAUGE	QTY	MODEL	VOLTS	PORT	PIN	QTY	
199360-6	BL1041B	12VMAX Li-ion	4.0Ah	✓	1pc	DC18RE	LXT + CXT	MULTI	3	1pc	Type 3
	BL1850B	18V Li-ion	5.0Ah	✓	1pc						
199359-1	BL1041B	12VMAX Li-ion	4.0Ah	✓	1pc	DC18RE	LXT + CXT	MULTI	2	1pc	Type 3
	BL1850B	18V Li-ion	5.0Ah	✓	1pc						

- BATTERY / CHARGERS
- FIXING / FASTENING [SCREWDRIVER BITS / IMPACT SOCKETS]
- DRILLING [WOOD / METAL / MASONRY]
- DRILLING / DEMOLITION [CONCRETE]
- CUTTING [METAL]
- DIAMOND
- GRINDING ACCESSORIES
- SANDING / POLISHING ACCESSORIES
- SAWING ACCESSORIES
- ROUTERS / PLANERS ACCESSORIES
- CLEANERS ACCESSORIES
- HEAT GUN / LASERS ACCESSORIES
- STAPLES / PINS NAILS BRAD NAILS
- GARDEN TOOLS ACCESSORIES
- HAND TOOLS / COMBINATION SETS

BATTERY / CHARGERS

FIXING FASTENING (SCREWDRIVER BITS / IMPACT SOCKETS)

DRILLING (WOOD / METAL / MASONRY)

DRILLING / DEMOLITION (CONCRETE)

CUTTING (METAL)

DIAMOND

GRINDING ACCESSORIES

SANDING / POLISHING ACCESSORIES

SAWING ACCESSORIES

ROUTERS / PLANERS ACCESSORIES

CLEANERS ACCESSORIES

HEAT GUN / LASERS ACCESSORIES

BRAD NAILS/ PINS STAPLER

GARDEN TOOLS ACCESSORIES

HAND TOOLS / COMBINATION SETS

Battery Protector

Type A: Shock absorbing frame protects batteries from damage



Type A

For Battery	Part No.
BL1430, BL1830, BL1850, BL1860	194649-7

Type B: Designed to protect the battery cartridge from dust and dripping water in outdoor applications or harsh environments



Type B

For Model	For Battery	Part No.
DTD134	BL1415, BL1430, BL1440	195797-5
DTD146, DTD147, DTD148, DTS141,	BL1815/N, BL1830, BL1840, BL1850	195798-3

Bulb for Cordless Torch

2pcs per set



For model	Voltage	Part No.
BML185Z	18V	A-90261
ML120, ML140	14.4V, 12V	A-83973
ML121	9.2V, 12V	A-30673
ML702	7.2V	192242-1
ML902, ML903	9.6V	192545-3

Tool Catcher Set

- Enables to hook the machine on a snap hook of waist belt.
- This is convenient for temporarily hanging the tool from belt.
- Usage of this clip helps users to keep their hands free while working at elevated work site.

Type A: Tool catcher set can be used for below types of cordless machine

- DDA ANGLE DRILL
- DDF DRIVER DRILL
- DHP PERCUSSION DRIVER DRILL
- DTD IMPACT DRIVER
- DTP 4 MODE IMPACT DRIVER
- DTW IMPACT WRENCH
- DPT PIN NAILER
- DST STAPLER



Type B: Tool catcher set with shoulder belt

Can be used with DTD152, DTD134, DTD148, DTD170, DTS141, DTW190, DTW250, DTW251, DTW280, DTW281, DTW285



For model	Part No.
Type A	197043-2
Type B	197941-0

Work Light Stand (Tripod)



Type: A



Type: B



Type: C



For Model	Mount Type	Type	Set Screw	Part No.
DML805	992-1,750mm (Up to two lights can be mounted)	A	M8	GM00001381
DML809, DML811	1,300-2,000mm (Up to two lights can be mounted)	B	M10 bolt & nut	GM00002073
DML805	Vise - Use for mounting DML805 on a scaffolding pipe	C	M8	GM00001396

Fixing / Fastening

Screwdriver Bits, Impact Sockets







BATTERY / CHARGERS

Phillips bits

Wide variety of bit types for all screwdriving needs

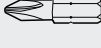
FIXING FASTENING (SCREWDRIVER BITS / IMPACT SOCKETS)

Driver type Shank type		1/4" Hex. Shank type			1/4" Hex. Shank type		NZ	1/4" Hex. Shank type		NZ
		A	C-form		B	E-form (Single Ended)		C	E-form (Double Ended)	
Phillips (PH)	Slotted (SL)									

DRILLING (WOOD / METAL / MASONRY)

Phillips bits

DRILLING / DEMOLITION [CONCRETE]

CUTTING [METAL]

MULTI TOOL ACCESSORIES

DIAMOND [CUTTING / GRINDING]

GRINDING ACCESSORIES

SANDING / POLISHING ACCESSORIES

SAWING ACCESSORIES

ROUTERS / PLANERS ACCESSORIES

CLEANERS ACCESSORIES

HEAT GUN / LASERS ACCESSORIES

BRAD NAILS/ PINS STAPLER

GARDEN TOOLS ACCESSORIES

HAND TOOLS / COMBINATION SETS

	Driver	Size	Length (mm)	Shank Type	Per Pkg	Part No
		Ph 2	45	NZ - C	3	798308-1
		Ph 2	45	NZ - C, Hard	1	784229-3
		Ph 2	65	NZ - C	3	B-04787
		Ph 2	65	NZ - C	1	784203-1
		Ph 2	65	NZ - C, Hard	1	784230-8
		Ph 2	82	NZ - B	3	798336-6
		Ph 2	110	NZ - B	1	784234-0
		Ph 2	110	NZ - C	3	798337-4
		Ph 2	110	NZ - C	1	784206-5

Phillips bits

	Driver	Size	Length (mm)	Shank Type	Per Pkg	Part No	
	+	Ph 2	117	NZ - B for model 6834	5	A-12697	BATTERY / CHARGERS FIXING FASTENING (SCREWDRIVER BITS / IMPACT SOCKETS)
	+	Ph 2	132	NZ - B for model 6835D	5	A-16536	DRILLING (WOOD / METAL/ MASONRY) DRILLING / DEMOLITION [CONCRETE]
	+	Ph 2	146	for model 6834	5	A-19825	CUTTING [METAL]
	+	Ph 2	150	NZ - C	3	798338-2	MULTI TOOL ACCESSORIES
	+	Ph 2	162	NZ - B for model 6842 DFR550	5	B-10481	DIAMOND [CUTTING / GRINDING] GRINDING ACCESSORIES
	+	Ph 2	250	NZ - C	1	784221-9	SANDING / POLISHING ACCESSORIES
	+	Ph 3	45	NZ - C	3	798310-4	SAWING ACCESSORIES
	+	Ph 3	50	NZ - C	10	P-06080	ROUTERS / PLANERS ACCESSORIES CLEANERS ACCESSORIES
	+	Ph 3	65	NZ - C	3	798311-2	HEAT GUN / LASERS ACCESSORIES
	—	Ph 3	110	NZ - C	3	798339-0	BRAD NAILS/ PINS STAPLER
	+ -	Ph 2 - SL 0.8	45	NZ - C	1	784614-0	GARDEN TOOLS ACCESSORIES HAND TOOLS / COMBINATION SETS

BATTERY / CHARGERS

FIXING FASTENING (SCREWDRIVER BITS / IMPACT SOCKETS)

DRILLING (WOOD / METAL / MASONRY)

DRILLING / DEMOLITION (CONCRETE)

CUTTING (METAL)

DIAMOND

GRINDING ACCESSORIES

SANDING / POLISHING ACCESSORIES

SAWING ACCESSORIES

ROUTERS / PLANERS ACCESSORIES

CLEANERS ACCESSORIES

HEAT GUN / LASERS ACCESSORIES

BRAD NAILS / PINS STAPLER

GARDEN TOOLS ACCESSORIES

HAND TOOLS / COMBINATION SETS

Phillips insert bits



	Drive	Size	Overall Length (mm)	Shank Type	Per Pkg	Part No
	+	PH 1	25	A	10	P-06030
	+	Ph 2	25	A	10	P-06052 / B-23466
	+	Ph 2	25	A	3	798398-4
	+	PH 3	25	A	3	798314-6

Slotted bits

- Wide variety of bit types for all screwdriving needs



	Drive	A(mm)	B(mm)	Length (mm)	Shank Type	Per Pkg	Part No
	⊖	0.6	5.0	45	NZ - B	3	798301-5
	⊖	0.8	6.0	70	NZ - B	3	798298-8
	⊖	1.0	6.35	45	NZ - B	3	798299-6
	⊖	1.2	8.0	45	NZ - B	3	798300-7
	⊖	1.2	8.0	70	NZ - B	3	798302-3
	⊖	1.2	10	52	NZ - B	3	798303-1
	⊖	1.2	10	70	NZ - B	3	798304-9
	⊖	0.8	5.0	82	NZ - B	3	798335-8

Flexible shaft bit

- Flexible extension for screwing in confined, difficult to access corners.
- Application: Kitchens, Joinery, Drilling
- Suitable for carpenters, interior decoration suppliers, plumbers, electric equipment supplier and car maintenance suppliers.

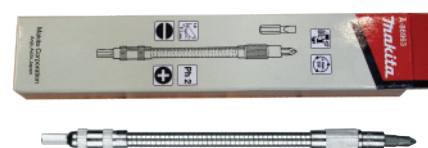

Length (mm)	Per Pkg	Part No
300mm	1	B-51867

Phillips Magnetic bit holder

(For insert bit)



	TYPE	SIZE (MM)	LENGTH (MM)	FOR MODEL	PER PKG	PART NO
	Magnetic	6.35	60	6821	1	784811-8
	Magnetic	6.35	60	6821	1	P-05979
	Magnetic	6.35	75	6823, 6824, 6825	1	P-05985
	Magnetic	6.35	76	6823, 6824, 6825	1	784801-1
	Non-Magnetic	6.35	76	-	1	784604-3

BATTERY / CHARGERS

FIXING / FASTENING [SCREWDRIVER BITS / IMPACT SOCKETS]

DRILLING [WOOD / METAL / MASONRY]

DRILLING / DEMOLITION [CONCRETE]

CUTTING [METAL]

DIAMOND

GRINDING ACCESSORIES

SANDING / POLISHING ACCESSORIES

SAWING ACCESSORIES

ROUTERS / PLANERS ACCESSORIES

CLEANERS ACCESSORIES

HEAT GUN / LASERS ACCESSORIES

STAPLES / PINS NAILS BRAD NAILS

GARDEN TOOLS ACCESSORIES

HAND TOOLS / COMBINATION SETS

Magnetic Bit holder

Holds all 1/4" bits securely for use with 3 Jaw or Maklok Chuck and 1/4" Hex drive tools

	Type / Size	Part No
	1 x Magnetic Bit Holder Size: 1/4" x 75mm	P-51982

Magnetic Nut Setter

For use with 3 Jaw, Maklok chuck and 1/4" Hex drive tools

	Type / Size	Part No
	1x Magnetic Nut Setter Size: 7mm	P-51708
	1x Magnetic Nut Setter Size: 5/16" mm	P-51742
	1x Magnetic Nut Setter Size: 8mm	P-51714
	1x Magnetic Nut Setter Size: 10mm	P-51720
	1x Magnetic Nut Setter Size: 13mm	P-51736

Hex to Square Socket Adaptor

For use with 3 Jaw, Maklok chuck and 1/4" Hex drive tools

	Type / Size	Part No
	1x Hex to Square Socket Adaptor Size: 1/4" x 3/8"	P-51839
	1x Hex to Square Socket Adaptor Size: 1/4" x 1/2"	P-51845

Maklok Chuck

For use on 1/4" Drive Tools and 3 Jaw Chucks

	Type / Size	Part No
	1x Maklok Quick Change Chuck	P-51421

BATTERY / CHARGERS

FIXING FASTENING (SCREWDRIVER BITS / IMPACT SOCKETS)

DRILLING (WOOD / METAL / MASONRY)

DRILLING / DEMOLITION (CONCRETE)

CUTTING [METAL]

MULTI TOOL ACCESSORIES

DIAMOND [CUTTING / GRINDING]

GRINDING ACCESSORIES

SANDING / POLISHING ACCESSORIES

SAWING ACCESSORIES

ROUTERS / PLANERS ACCESSORIES

CLEANERS ACCESSORIES

HEAT GUN / LASERS ACCESSORIES

BRAD NAILS/ PINS STAPLER

GARDEN TOOLS ACCESSORIES

HAND TOOLS / COMBINATION SETS

31pcs Screw Bit Set In Battery Type Case

- 31pcs Screw Bit set comes in Makita original battery shaped case with a transparent cover.
- Ideal for equipment repairmen, construction workers, carpenters and DIY users.
- Comes in a Clamshell package.
- It is convenient for single hand opening because of one-touch button
- Can be put in the space for spare battery in a power tool plastic case.



• Note: Battery case can not be attached to makita power tools

TYPE	SHANK	SIZE	LENGTH	PKG WITH COUNTRY OF ORIGIN	PART NO
Screwbit	C-form	PH0, PH1, PH2x4, PH3, PZ0, PZ1, PZ2x4, PZ3, T10, T15, T20x2, T25x2, T27, T30, T40 HEX3, HEX4, HEX5, HEX6 SL 0.6X4.5, SL 0.8X5.5, SL 1.2X6.5	25mm	YES	B-69901
Bit holder	1/4" Hex		60mm		

10pcs Screw Bit Set In Battery Clamshell

- The Screwdriver Bit Set can be attached to your waist belt using the carabiner hook to avoid dropping and for safety in working in a high place.

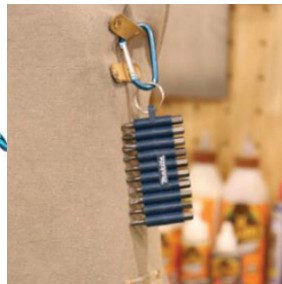

TYPE	SHANK	SHANK LENGTH	SIZE	PACKAGE TYPE	PART NO
Screw Bits	1/4" Hex	50mm	PH0, PH1, PH2x4, PH3, PZ0, PZ1, PZ2x4, PZ3, T10, T15, T20x2, T25x2, T27, T30, T40 HEX3, HEX4, HEX5, HEX6 SL 0.6X4.5, SL 0.8X5.5, SL 1.2X6.5	Plastic + Cardboard Clamshell	D-67620

35pcs Impact BLACK Screw Bit Set



- Impact Black is a high durability range for professional use.
- 35pcs set comes in a Plastic case + Cardboard clamshell as 10pcs set



Black coating is designed to prevent rusting



x10

TYPE	SHANK	SIZE	LENGTH	PKG WITH COUNTRY OF ORIGIN	PCS	PART NO
Screw Bits	C-form	1xPH1,3xPH2,1xPH3 1xPZ1,3xPZ2, 1xPZ3 1xT15, 2xT20, 2xT25,1xT30	25mm	YES	10PC SET	E-06638-10
	E-form	1xPH1,2xPH2,1xPH3 1xPZ1,2xPZ2, 1xPZ3 1xT15,1xT20,2xT25,1xT30 1xSL0.8x5.5	50mm			
Magnetic bit holder			60mm			
Magnetic Nut setter:6mm,8mm,10mm,13mm			50mm			

Torsion bits

- a) Double ended torsion bits
- b) Double ended twist torsion bits

Advantages of Torsion bits

The high torque produced by impact drivers will damage standard screwdriver bits but the new Makita double ended torsion screwdriver bit out performs beyond all expectations, lasting up to 10 times longer than a standard bit.

- Torsion bits can last longer than a regular screw bit.
- Absorbs the shock on contact
- Prevents the bit from chipping and extends the life
- For continuous high torque fastening with impact drivers.
- Ideal for self-drilling metal screws and long wood screws

a) Double ended torsion bits

- Can last up to 10x longer than a regular screw bit.
- Double ended 65mm in length
- For continuous high torque fastening
- Shock absorbing
- Magnetic
- Ideal for self-drilling and long screws



TYPE	SHAPE	LENGTH (MM)	FOR	PER PKG	PKG WITH COUNTRY OF ORIGIN	PART NO
Magnetic	PH2	65	Impact drivers	3	Yes	B-55376

b) Double ended twist torsion bits

- Can last up to 20x longer than a regular screw bit.
- Double ended 65mm in length
- For continuous high torque fastening
- Shock absorbing
- Magnetic
- Ideal for self-drilling and long screws
- The bottle has both magnetizing and demagnetizing function.

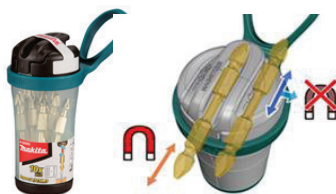
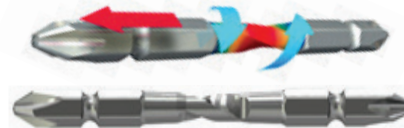

Magnetic Bottel



TYPE	SHAPE	LENGTH (MM)	FOR	PER PKG	PART NO
Magnetic	PH2	65	Impact drivers	10pcs of bit in each bottle.	B-63127

BATTERY / CHARGERS

FIXING FASTENING (SCREWDRIVER BITS / IMPACT SOCKETS)

DRILLING (WOOD / METAL/ MASONRY)

DRILLING / DEMOLITION [CONCRETE]

CUTTING [METAL]

MULTI TOOL ACCESSORIES

DIAMOND [CUTTING / GRINDING]

GRINDING ACCESSORIES

SANDING / POLISHING ACCESSORIES

SAWING ACCESSORIES

ROUTERS / PLANERS ACCESSORIES

CLEANERS ACCESSORIES

HEAT GUN / LASERS ACCESSORIES

BRAD NAILS/ PINS STAPLER

GARDEN TOOLS ACCESSORIES

HAND TOOLS / COMBINATION SETS

BATTERY / CHARGERS

FIXING FASTENING (SCREWDRIVER BITS / IMPACT SOCKETS)

DRILLING (WOOD / METAL / MASONRY)

DRILLING / DEMOLITION (CONCRETE)

CUTTING [METAL]

MULTI TOOL ACCESSORIES

DIAMOND [CUTTING / GRINDING]

GRINDING ACCESSORIES

SANDING / POLISHING ACCESSORIES

SAWING ACCESSORIES

ROUTERS / PLANERS ACCESSORIES

CLEANERS ACCESSORIES

HEAT GUN / LASERS ACCESSORIES

BRAD NAILS/ PINS STAPLER

GARDEN TOOLS ACCESSORIES

HAND TOOLS / COMBINATION SETS

Socket bit

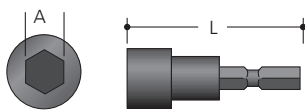

Type	Bolt Size	A(mm)	L(mm)	Shank Type	Per Pkg	Part No
Non-Magnetic	M3	5.5	55	NZ - B	1	784401-7
Non-Magnetic	M4	7.0	55	NZ - B	1	784402-5
Non-Magnetic	M5	8.0	55	NZ - B	1	784403-3
Non-Magnetic	M6	10	55	NZ - B	1	784405-9
Non-Magnetic	M5	8.0	65	MZ - B	1	784415-6
Magnetic	M6	10	65	MZ - B	1	784806-1
Non-Magnetic	M6	10	70	NZ - B	1	784406-7
Non-Magnetic	M8	12	86	NZ - B	1	784407-5
Non-Magnetic	M8	13	55	NZ - B	1	784408-3
Non-Magnetic	M8	14	55	NZ - B	1	784409-1
Non-Magnetic	M10	17	55	NZ - B	1	784416-4

Type	Bolt Size	A(inches)	L(mm)	Shank Type	Per Pkg	Part No
Magnetic	1/8"	1/4"	65	MZ - B	1	784803-7
Magnetic	3/16"	5/16"	55	NZ - B	1	784808-7
Magnetic	3/16"	5/16"	65	MZ - B	1	784804-5
Magnetic	1/4"	3/8"	65	MZ - B	1	784802-9
For self drilling screw	1/4"	3/8"	55	NZ - B	1	784404-1
Magnetic	1/4"	3/8"	55	NZ - B	1	784809-5
Magnetic	1/2"	7/16"	65	MZ - B	1	784805-3
Non-Magnetic	1/2"	7/16"	65	MZ - B	1	784414-8

Locator assembly

- For Screwdrivers and Drywall Screwdrivers

	For Model	Per Pkg	Part No
	6801B	1	122211-8
	6820V	1	122450-0
	6821	1	152483-1
	6823	1	151760-8
	6824, 6825	1	151726-8
	6826	1	152823-3
	FS2300, FS4300, FS6300	1	158876-0

Front cap

- For socket bit
- For Screwdrivers and Drywall Screwdrivers



For Model	Size (mm)	Per Pkg	Part No
6801B, 6850BV, 6827, FS2700	12	1	322070-2

Autofeed attachment set

- For Drywall screwdrivers
- Able to fasten even in a tight corner
- Reverse function
- One-touch attachment / removal with 8 angle settings



For Model	Standard Equipment Bit	Part No
DFS250, DFS452, FS2300, FS4300, FS6300	Phillips No.2, Square No.2	199078-9



Optional Bits for Autofeed attachment set
Phillips No.2 (5pcs)
Part No. **199155-7**

BATTERY / CHARGERS

FIXING FASTENING (SCREWDRIVER BITS / IMPACT SOCKETS)

DRILLING (WOOD / METAL / MASONRY)

DRILLING / DEMOLITION [CONCRETE]

CUTTING [METAL]

MULTI TOOL ACCESSORIES

DIAMOND [CUTTING / GRINDING]

GRINDING ACCESSORIES

SANDING / POLISHING ACCESSORIES

SAWING ACCESSORIES

ROUTERS / PLANERS ACCESSORIES

CLEANERS ACCESSORIES

HEAT GUN / LASERS ACCESSORIES

BRAD NAILS / PINS STAPLER

GARDEN TOOLS ACCESSORIES

HAND TOOLS / COMBINATION SETS



Drywall screw strip

- For Auto Feed Screwdrivers
- 50pcs x 20 strips per box

	For Model	Diameter (mm)	Per Pkg	Part No
	DFR550, 6832, 6834, 6835D, 6842	ø3.9 x 41	1000	P-04139
		ø4.0 x 32	1000	A-12413
		ø4.0 x 40	1000	A-12429

Extension handle bar

- For Auto Feed Screwdrivers
- More comfortable and less fatigue and faster installation
- Enables user to use auto feed screwdriver on floor or ceiling

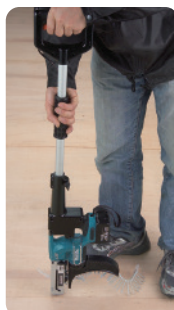

For Model	Dimension	Per Pkg	Part No
6832, 6834	890-990mm	1	192501-3
DFR550	-	1	194500-1

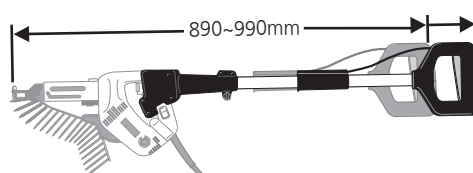

BATTERY / CHARGERS

FIXING FASTENING (SCREWDRIVER BITS / IMPACT SOCKETS)

DRILLING (WOOD / METAL / MASONRY)

DRILLING / DEMOLITION (CONCRETE)

CUTTING (METAL)

MULTI TOOL ACCESSORIES

DIAMOND (CUTTING / GRINDING)

GRINDING ACCESSORIES

SANDING / POLISHING ACCESSORIES

SAWING ACCESSORIES

ROUTERS / PLANERS ACCESSORIES

CLEANERS ACCESSORIES

HEAT GUN / LASERS ACCESSORIES

BRAD NAILS/ PINS STAPLER

GARDEN TOOLS ACCESSORIES

HAND TOOLS / COMBINATION SETS

Impact socket for impact wrenches

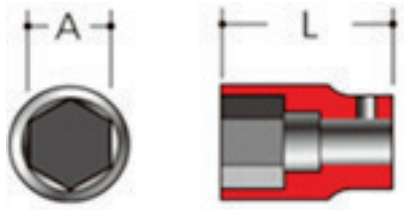

For 1/2"(12.7mm) anvil
Length 81.5mm



A (MM)	L (MM)	PART NO
08mm	81.5mm	B-52146
10mm	81.5mm	B-52152
11mm	81.5mm	B-52168
12mm	81.5mm	B-52174
13mm	81.5mm	B-52180
14mm	81.5mm	B-52196
16mm	81.5mm	B-52205
17mm	81.5mm	B-52211
18mm	81.5mm	B-52227
19mm	81.5mm	B-52233
21mm	81.5mm	B-52249
22mm	81.5mm	B-52255
24mm	81.5mm	B-52261
27mm	81.5mm	B-52277
30mm	81.5mm	B-52283
32mm	81.5mm	B-52299

O ring set for 1/2"square impact socket



Size	Set	Part No
8mm -16mm	3pc	B-54542
17mm	3pc	B-54558
18mm and 19mm	3pc	B-54564
20mm - 32mm	3pc	B-54570

Pin set for 1/2"square impact socket



Size	Set	Part No
8mm -16mm	3pc	B-54586
17mm	3pc	B-54592
18mm and 19mm	3pc	B-54601
20mm-32mm	3pc	B-54617

(all the above sockets are without O-ring & Pin)



Impact sockets for impact wrenches

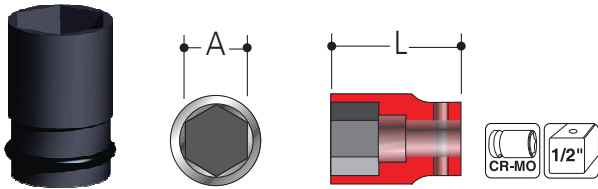

- For Impact Wrenches with 12.7mm (1/2") square drive.
- For model: 6953, 690VH, 6905B, TW0350, DTW285, DTW251, DTW181, DTW190, DTW450, DTW701, DTW300

A (mm)	L (mm)	Per Pkg	Part No
12	75	1	134867-5
13	38	1	134825-1
13	52	1	134827-7
14	38	1	134826-9
14	52	1	134828-5
17	38	1	134829-3
17	52	1	134830-8
19	38	1	134831-6
19	52	1	134832-4
19	78	1	134837-4
21	38	1	134838-2
21	52	1	134833-2
21	78	1	134839-0
22	38	1	134851-0
22	52	1	134834-0
23	38	1	134840-5
23	52	1	134835-8
24	45	1	134841-3
24	52	1	134836-6
26	50	1	134842-1
26	78	1	134843-9

- For Impact Wrenches with 12.7mm (1/2") square drive.
- For model: 6953, 690VH, 6905B, TW0350, DTW285, DTW251, DTW181, DTW190, DTW450, DTW300, DTW701

A (mm)	L (mm)	Per Pkg	Part No
27	50	1	134844-7
27	78	1	134845-5
30	50	1	134846-3
30	78	1	134847-1
32	50	1	134848-9
32	78	1	134849-7



- For Impact Wrenches 19mm (3/4") square drive.
- For model: 6906, DTW1001



A (mm)	L (mm)	Per Pkg	Part No
17	50	1	A-85494
17	95	1	A-85503
19	50	1	A-85519
19	95	1	A-85525
21	52	1	A-85531
21	95	1	A-85547
22	52	1	A-85553
22	95	1	A-85569
24	52	1	A-85575
24	95	1	A-85581
26	52	1	134853-6
26	95	1	134854-4
27	52	1	134855-2
27	95	1	134856-0
30	52	1	134857-8
30	95	1	134858-6
32	52	1	134871-4
32	95	1	134859-4
35	56	1	134860-9
36	56	1	134862-5
36	95	1	134863-3

- For Impact Wrenches with 25.4mm (1") square drive.
- For model: 6910, TW1000



A (mm)	L (mm)	Per Pkg	Part No
35	80	1	134864-1
36	80	1	134865-9
41	80	1	134872-2

(all the above sockets are with Pin and O-Ring)

BATTERY / CHARGERS

FIXING FASTENING (SCREWDRIVER BITS / IMPACT SOCKETS)

DRILLING (WOOD / METAL / MASONRY)

DRILLING / DEMOLITION [CONCRETE]

CUTTING [METAL]

MULTI TOOL ACCESSORIES

DIAMOND [CUTTING / GRINDING]

GRINDING ACCESSORIES

SANDING / POLISHING ACCESSORIES

SAWING ACCESSORIES

ROUTERS / PLANERS ACCESSORIES

CLEANERS ACCESSORIES

HEAT GUN / LASERS ACCESSORIES

BRAD NAILS / PINS STAPLER

GARDEN TOOLS ACCESSORIES

HAND TOOLS / COMBINATION SETS

BATTERY / CHARGERS

FIXING FASTENING (SCREWDRIVER BITS / IMPACT SOCKETS)

DRILLING (WOOD / METAL / MASONRY)

DRILLING / DEMOLITION (CONCRETE)

CUTTING [METAL]

MULTI TOOL ACCESSORIES

DIAMOND [CUTTING / GRINDING]

GRINDING ACCESSORIES

SANDING / POLISHING ACCESSORIES

SAWING ACCESSORIES

ROUTERS / PLANERS ACCESSORIES

CLEANERS ACCESSORIES

HEAT GUN / LASERS ACCESSORIES

BRAD NAILS/ PINS STAPLER

GARDEN TOOLS ACCESSORIES

HAND TOOLS / COMBINATION SETS

9pcs 1/2" Impact Socket with Socket Adapter Set

- It allows impact driver to fasten or loosen bolt and nut
- Ball type socket adapter allows easy attaching or detaching sockets

Sizes: 8, 10, 12, 13, 14, 15, 17, 18mm
Socket adapter 50mm



(1pc Socket Adaptor and 8pcs Impact Socket)



Rubber holder with Blister pack



TYPE	SHANK TYPE	SIZE	FOR	PER PKG	PKG WITH COUNTRY OF ORIGIN	PART NO
1/4"Hex (NZ)	NZ-B	SQ 1/2"	Impact drivers	9pcs/ (1 set)	Yes	B-55762

14pcs 1/2" Drive Deep Impact Socket Bit Set

- Deep socket makes it possible to fasten and loosen the nut to further long bolt and able to work on such a long protruded bolt



DESCRIPTION	SIZE (MM)	PER PKG	PKG WITH COUNTRY OF ORIGIN	PART NO
For 1/2" (12.7mm) anvil with O-ring and Pin	10, 11, 12, 13, 14, 16, 17, 19, 21, 22, 24, 27, 30, 32 x 81.5mm	14pcs/ (1 set)	Yes	B-52308

Extension for 1/2" Square Drive Impact Wrench

- To fasten bolts and nuts wherever deep socket cannot reach
- It has ball type extension which allows easy attaching or detaching sockets

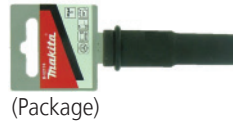
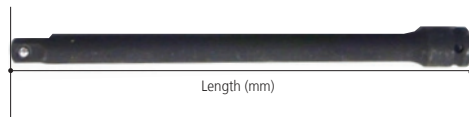

SIZE	LENGTH (MM)	PER PKG	PART NO EXTENSION	PART NO PIN	PART NO O-RING
1/2"	250	1	B-55706	B-54586	B-54542
1/2"	150	1	B-55712	B-54586	B-54542
1/2"	75	1	B-55728	B-54586	B-54542

Pin and O-ring are included with the socket

Extension for 1/2" | 3/5" | 1" Square Drive Impact Wrench

- To fasten bolts and nuts wherever deep socket cannot reach



FOR MODEL	SIZE	LENGTH (MM)	PER PKG	PART NO
6918D , 6953, 6904VH, DTW190, DTW181, DTW251, DTW281, DTW285, DTW300, DTW450, DTW701	1/2"	100	1	134874-8
DTW1001, 6906	3/4"	150	1	134997-2
6910, TW1000	1"	200	1	134870-6

(All the above sockets are with O-ring & Pin)

Bit Adapter Assembly

- For 1/2" Impact Wrenches.
- Enables tool to fasten machine screws.
- Comes with Pin and O ring
- Application: Cladding roofing steel



FOR MODEL	SIZE	PER PKG	PART NO
6918D , 6953, 6904VH, DTW190, DTW181, DTW251, DTW281, DTW285, DTW300, DTW450, DTW701	1/2"	1	134873-0

Universal Joint

- Universal joint alters angle of drive for impact wrenches.
- For use in a limited space where the tool cannot be held in line with the axis of the bolt or nut.
- Greater flexibility.

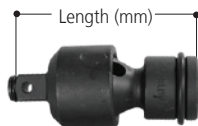

FOR MODEL	SIZE	LENGTH (MM)	PER PKG	PART NO
6918D , 6953, 6904VH, DTW190, DTW181, DTW251, DTW281, DTW285, DTW300, DTW450, DTW701	1/2"	84	1	134877-2
6906	3/4"	150	1	134998-0

(All the above sockets are with O-ring & Pin)

1/4" Hex shank screwdriver bits adapter

- for 1/2" square driver impact wrenches
- Enables tool to fasten machine screws.

Connects to 1/4" Hex shank

Sleeve chuck like the Impact driver's sleeve mechanism

Connects with 1/2" Square drive Impact Wrenches

Comes with Pin and O ring

1/4" Hex shank bits

Adapter

1/2" 1/2 Square Drive Impact Wrenches

FOR MODEL	SIZE	PER PKG	PART NO
6918D , 6953, 6904VH, DTW190, DTW181, DTW251, DTW281, DTW285, DTW300, DTW450, DTW701	1/2"	1	B-68476

Drill Chuck Assembly

For Impact Driver



FOR MODEL	PER PKG	PART NO.
CONNECT BIT 6.35-48 NZ FOR IMPACT DRIVER	1	191880-6

BATTERY / CHARGERS

FIXING FASTENING (SCREWDRIVER BITS / IMPACT SOCKETS)

DRILLING (WOOD / METAL / MASONRY)

DRILLING / DEMOLITION [CONCRETE]

CUTTING [METAL]

MULTI TOOL ACCESSORIES

DIAMOND [CUTTING / GRINDING]

GRINDING ACCESSORIES

SANDING / POLISHING ACCESSORIES

SAWING ACCESSORIES

ROUTERS / PLANERS ACCESSORIES

CLEANERS ACCESSORIES

HEAT GUN / LASERS ACCESSORIES

BRAD NAILS / PINS STAPLER

GARDEN TOOLS ACCESSORIES

HAND TOOLS / COMBINATION SETS

BATTERY / CHARGERS

Drill Bit Remover Set

Use it with the impact wrench for removing SDS-MAX bit stuck on rebar in concrete.



FOR MODEL

Use with impact Wrench

PER PKG

1

PART NO.

195870-1

FIXING FASTENING (SCREWDRIVER BITS / IMPACT SOCKETS)

DRILLING (WOOD / METAL/ MASONRY)

Earth Auger Drill Bits with 3/4" Impact Sockets and O ring

Earth Auger Drill Bit for 3/4" Impact Wrench (DTW1001 / TW001G)

These auger bits are suitable for installing wooden/metal poles on the ground for preparing Greenhouse or farming. These drill bits can also be used for installing fence for camping sites and fixing poles in desert camp areas



CUTTING [METAL]

MULTI TOOL ACCESSORIES

DIAMOND [CUTTING / GRINDING]

Size	Type	Part no:
20mm dia x 600mm long	with 3/4" Socket, Pin & O ring	B-54302
25mm dia x 600mm long	with 3/4" Socket, Pin & O ring	B-54318
30mm dia x 600mm long	with 3/4" Socket, Pin & O ring	B-54324
35mm dia x 600mm long	with 3/4" Socket, Pin & O ring	B-54330
40mm dia x 600mm long	with 3/4" Socket, Pin & O ring	B-57576

GRINDING ACCESSORIES

Angle Attachments for TL064 / TL065

Impact driver Impact Wrench

Straight head



Part No.

192440-7

Ratchet head



Part No.

192439-2

Socket Adapter for TL064 / TL065

Impact driver Impact Wrench

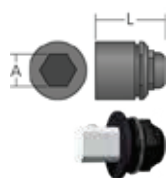

use with Ratchet head

Size Part No.

9.5mm (3/8") 134745-9
12.7mm (1/2") 134746-7



Socket adapter - WR100D

Ratchet Wrench

use with Ratchet head

NEW

Size Part No.

9.5mm (3/8") 191A50-3
6.3mm (1/4") 191A51-1



HEAT GUN / LASERS ACCESSORIES

BRAD NAILS/ PINS STAPLER

Grip Assembly

• For Impact Wrenches.



FOR MODEL

6906

6910

6910

TW1000

PER PKG

1

1

1

1

PART NO

122464-9

123018-5

122464-9

122727-3

GARDEN TOOLS ACCESSORIES

HAND TOOLS / COMBINATION SETS

DRILL BITS

[WOOD / METAL / MASONRY /
OTHER DRILL ACCESSORIES]

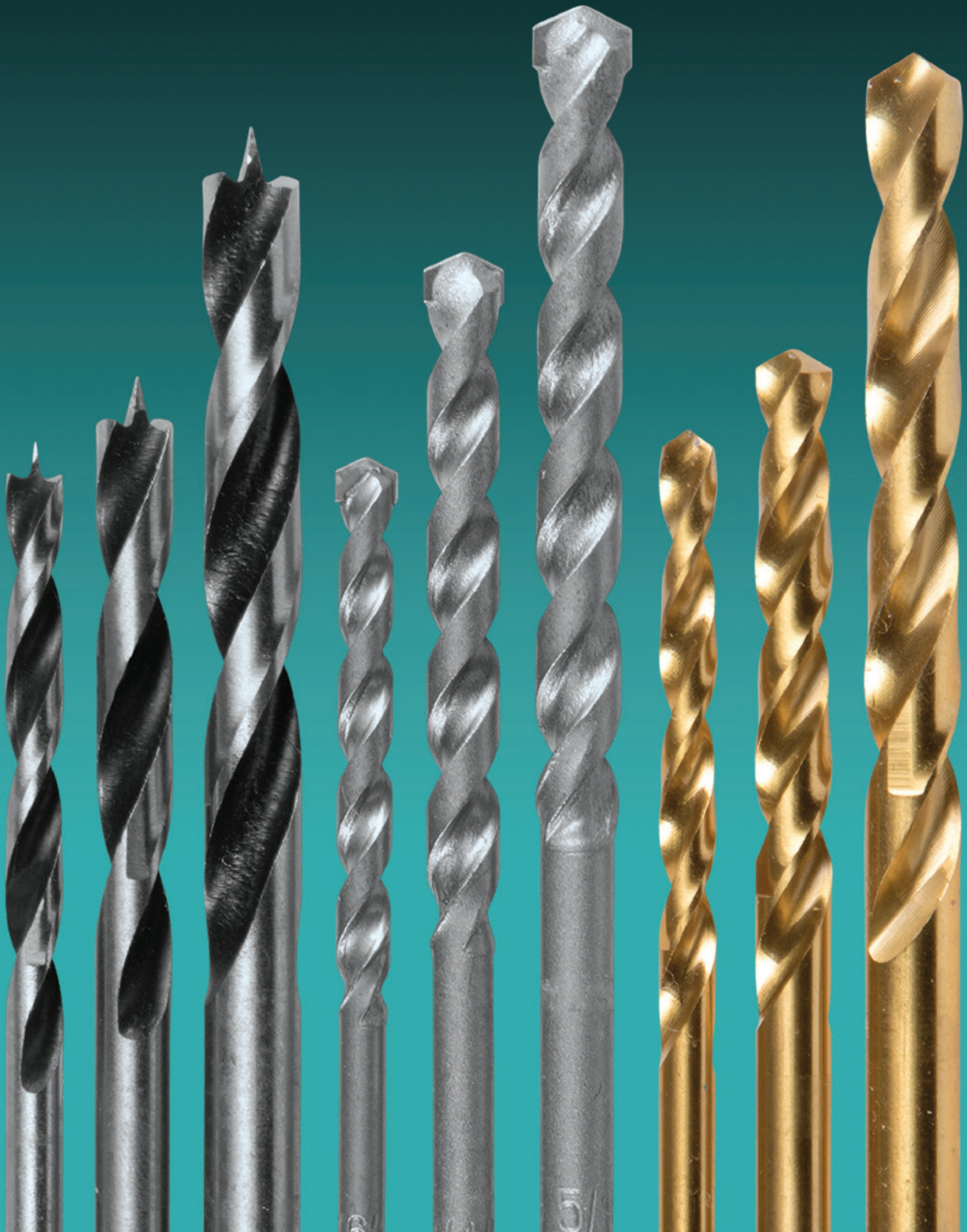

- BATTERY / CHARGERS
- FIXING FASTENING (SCREWDRIVER BITS / IMPACT SOCKETS)
- DRILLING (WOOD / METAL / MASONRY)**
- DRILLING / DEMOLITION [CONCRETE]
- CUTTING [METAL]
- MULTI TOOL ACCESSORIES
- DIAMOND [CUTTING / GRINDING]
- GRINDING ACCESSORIES
- SANDING / POLISHING ACCESSORIES
- SAWING ACCESSORIES
- ROUTERS / PLANERS ACCESSORIES
- CLEANERS ACCESSORIES
- HEAT GUN / LASERS ACCESSORIES
- BRAD NAILS/ PINS STAPLER
- GARDEN TOOLS ACCESSORIES
- HAND TOOLS / COMBINATION SETS

Wood drill bits classification

Wood drill bit



Suitable for: Drilling holes with small to medium diameter.

Applications: Soft plastics and general wood.

Features: Highly effective for boring more clean and precise holes than flat bit.



Auger bit



Suitable for: Drilling of deep holes with medium to large diameter holes

Applications: Soft and hard wood.

Features: Threaded screw point push the bit into the work piece to providing a fast, easy to use and self feeding action. Highly effective for boring clean and precise holes compared to flat bit and wood drill bit.



Flat bit



Suitable for: Drilling holes with medium to large diameters

Applications: Soft wood or soft plastic.

Features: Hexagon shank prevents chuck slipping. Grooved notch in head and outer cutting tips at the circumference of the hole



Standard 3 Point Wood Bit

- These bits are excellent when applied to soft to medium wood.
- They have a polished steel body with a centering point.

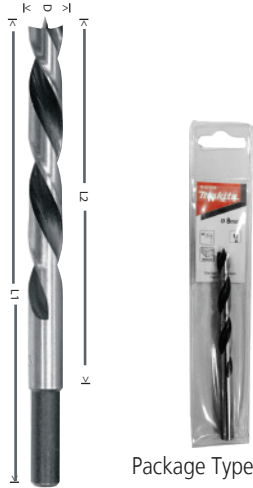

Bit Dia (D) (mm)	Overall Length (L1) (mm)	Working Length (L2)(mm)	Per Pkg	Part No
3	60	33	1	D-07026
4	75	43	1	D-07032
5	85	52	1	D-07048
6	95	57	1	D-07054
7	110	69	1	D-07060
8	115	75	1	D-07076
9	125	81	1	D-07082
10	135	87	1	D-07098
12	155	101	1	D-07107
14	170	108	1	D-07113
16	180	105	1	D-07129
18	200	120	1	D-07135
20	200	130	1	D-07141

BATTERY / CHARGERS

FIXING FASTENING (SCREWDRIVER BITS / IMPACT SOCKETS)

DRILLING (WOOD / METAL/ MASONRY)

DRILLING / DEMOLITION [CONCRETE]

CUTTING [METAL]

MULTI TOOL ACCESSORIES

Auger Bits

- Drilling of deep holes with medium to large holes.
- The bits comes in sizes 6mm to 30mm, self feeding and with a high cutting rate.

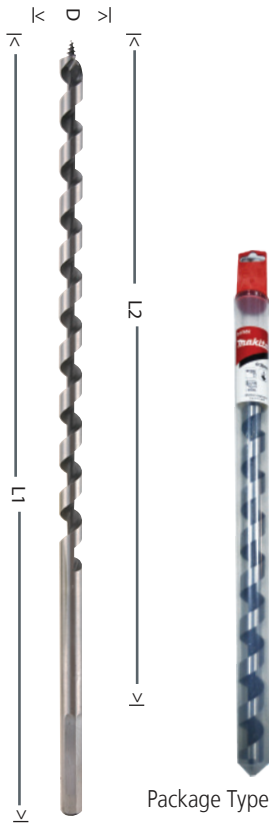

Bit Dia (D) (mm)	Overall Length (L1) (mm)	Working Length (L2)(mm)	Per Pkg	Part No
6	250	180	1	D-07331
8	250	180	1	D-07347
10	250	180	1	D-07353
12	250	180	1	D-07369
14	250	180	1	D-07375
16	250	180	1	D-07381
18	250	180	1	D-07397
20	250	180	1	D-07406
22	250	180	1	D-07412
24	250	180	1	D-07428

DIAMOND [CUTTING / GRINDING]

GRINDING ACCESSORIES

SANDING / POLISHING ACCESSORIOIES

SAWING ACCESSORIES

ROUTERS / PLANERS ACCESSORIES

Bit Dia (D) (mm)	Overall Length (L1) (mm)	Working Length (L2)(mm)	Per Pkg	Part No
8	450	380	1	D-07559
10	450	380	1	D-07565
12	450	380	1	D-07571
14	450	380	1	D-07587
16	450	380	1	D-07593
18	450	380	1	D-07602
20	450	380	1	D-07618
22	450	380	1	D-07624
24	450	380	1	D-07630
26	450	380	1	D-07646
28	450	380	1	D-07652
30	450	380	1	D-07668

CLEANERS ACCESSORIES

HEAT GUN / LASERS ACCESSORIES

BRAD NAILS/ PINS STAPLER

GARDEN TOOLS ACCESSORIES

HAND TOOLS / COMBINATION SETS

- BATTERY / CHARGERS
- FIXING FASTENING (SCREWDRIVER BITS / IMPACT SOCKETS)
- DRILLING (WOOD / METAL / MASONRY)
- DRILLING / DEMOLITION [CONCRETE]
- CUTTING [METAL]
- MULTI TOOL ACCESSORIES
- DIAMOND [CUTTING / GRINDING]
- GRINDING ACCESSORIES
- SANDING / POLISHING ACCESSORIES
- SAWING ACCESSORIES
- ROUTERS / PLANERS ACCESSORIES
- CLEANERS ACCESSORIES
- HEAT GUN / LASERS ACCESSORIES
- BRAD NAILS/ PINS STAPLER
- GARDEN TOOLS ACCESSORIES
- HAND TOOLS / COMBINATION SETS

Spade (Flat) Bit

- Contractor quality flat bits, suitable for soft woods.
- Diameters 6 - 36mm Hex shank for high torque application.
- Hexagon shank prevents chuck slippage. Grooved notch in head and outer cutting tips at the circumference of the hole



Package Type

Bit Dia (D) (mm)	Overall Length (L1) (mm)	Per Pkg	Part No
6	150	1	D-07674
8	150	1	D-07680
10	150	1	D-07696
12	150	1	D-07705
14	150	1	D-07711
15	150	1	D-07727
16	150	1	D-07733
18	150	1	D-07749
20	150	1	D-07755
22	150	1	D-07761
24	150	1	D-07777
25	150	1	D-07783
26	160	1	D-07799
28	160	1	D-07808
30	160	1	D-07814
32	160	1	D-07820
34	160	1	D-07836
35	160	1	D-07842
36	160	1	D-07858

5pcs Flat Bit

For use with any 3 Jaw chuck, Maklok chuck and 1/4" Hex Drive Tools



Working Length (mm)	length (mm)	Size (mm)	Pc/ Pkg	Part No
120	150	16	1	P-46084
120	150	18	1	
120	150	22	1	
120	150	25	1	
120	150	32	1	

8pcs Flat Bit

For use with any 3 Jaw chuck, Maklok chuck and 1/4" Hex Drive Tools

With plastic case



Working Length (mm)	length (mm)	Size (mm)	Pc/ Pkg	Part No
120	150	12	1	P-52093
120	150	14	1	
120	150	16	1	
120	150	18	1	
120	150	20	1	
120	150	22	1	
120	150	25	1	
120	150	32	1	

7 pcs. Self feeding bit set



- Suitable for drilling large diameter holes for pipe and conduit in wood.
- Threaded screw point pull the bit into the work piece providing a fast, easy to use self feeding action. Suitable for plumbing and electrical installation, etc.

Bit Dia / Type	Per Pkg	Part No
1"(25mm)	1	D-36005
1-1/4"(32mm)	1	
1-1/2"(38mm)	1	
2"(51mm)	1	
2-9/16"(65mm)	1	
3"(76mm)	1	
Extension bar 5-1/2"(140mm)	1	
Screw point 1-1/4" x 2"	3	
Screw point 3/8" x 2"-3/4"	1	
Hex wrench	2	
Replacement screw	2	

BATTERY / CHARGERS

FIXING FASTENING (SCREWDRIVER BITS / IMPACT SOCKETS)

DRILLING (WOOD / METAL/ MASONRY)

DRILLING / DEMOLITION [CONCRETE]

CUTTING [METAL]

MULTI TOOL ACCESSORIES

Forstner bit 5pcs. set with wooden case

- Suitable for drilling of blind holes or penetrating holes of medium to large diameter with high quality. Suitable for precise working like a making furniture



Bit Dia	Per Pkg	Part No
15mm	1	D-47357
20mm	1	
25mm	1	
30mm	1	
35mm	1	

DIAMOND [CUTTING / GRINDING]

GRINDING ACCESSORIES

SANDING / POLISHING ACCESSORIES

SAWING ACCESSORIES

SDS-PLUS WOOD DRILL BIT

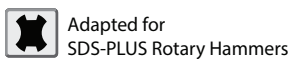

Can be used on SDS PLUS Hammers to drill wood without the need of having an additional chuck.



Bit Dia (mm)	Overall Length (mm)	Working Length (mm)	Per Pkg	Part No
4	105	43	1	B-57489
5	116	52	1	B-57495
6	123	57	1	B-57504
8	147	75	1	B-57510
10	163	87	1	B-57526

ROUTERS / PLANERS ACCESSORIES

CLEANERS ACCESSORIES

HEAT GUN / LASERS ACCESSORIES

Glass and Tiles Drill Bit

- 1/4" Hex shank
- Used in Rotary mode with almost any hammer drill and rotary drill
- Ideal for drilling holes in glass and tiles
- Gives a quick, clean and precise hole without cracks



Bit Dia (D) (mm)	Overall Length L1 (mm)	Per Pkg	Part No
4	65	1	D-15942
5	65	1	D-15958
6	65	1	D-15964
8	70	1	D-15970
10	80	1	D-15986

BRAD NAILS/ PINS STAPLER

GARDEN TOOLS ACCESSORIES

HAND TOOLS / COMBINATION SETS

HSS metal drill bit series

Range

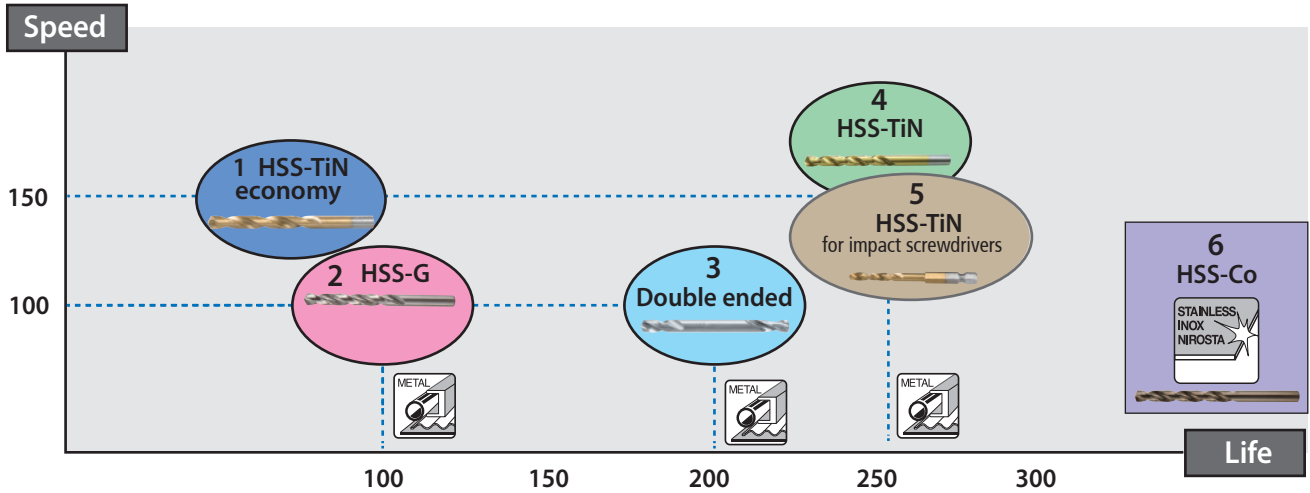

Description	2	2	3	4	5	6
Range	★★★	★★★	★★★	★★★★	★★★★	Specialized
Description	HSS-TiN economy	HSS-G	Double ended	HSS-TiN	HSS-TiN impact screwdrivers	HSS-Co5%
Made of						
Process of manufacturing			Ground			
Tip geometry	Split point 135° 	Chisel edge 118° 	Split point 135° 			Split point 135°
Surface	TiN coating Long life	Bright finish 		TiN coating Long life		Amber finish (Rust resistant)
Shank		Straight (Cylindrical) 		Straight (Cylindrical) Straight or 1/4"Hex 	Straight or 1/4"Hex 	Straight (Cylindrical)

Ground:
Drill bits ground from the block with excellent surface quality

135°split point:
Ensure no walking and start fast, on contact

Material chart		1	2	3	4	5	6
Material	Wood	A	A	A	A	A	
	Plastic	AA	AA	AA	AA	AA	
	Non-ferrous metal	AA	AA	AA	AA	AA	A
	Sheet steel	AA	AA	AA	AA	AA	A
	Cast iron	AA	AA		AA	AA	AA
	Alloy steel	AA	AA		AA	AA	AA
	Stainless steel	A	A		A	A	AA

AA : Recommended

A : Acceptable

Non-ferrous metal (Such as Copper, Nickel and Zinc)

- BATTERY / CHARGERS
- FIXING FASTENING (SCREWDRIVER BITS / IMPACT SOCKETS)
- DRILLING (WOOD / METAL / MASONRY)
- DRILLING / DEMOLITION [CONCRETE]
- CUTTING [METAL]
- MULTI TOOL ACCESSORIES
- DIAMOND [CUTTING / GRINDING]
- GRINDING ACCESSORIES
- SANDING / POLISHING ACCESSORIES
- SAWING ACCESSORIES
- ROUTERS / PLANERS ACCESSORIES
- CLEANERS ACCESSORIES
- HEAT GUN / LASERS ACCESSORIES
- BRAD NAILS/ PINS STAPLER
- GARDEN TOOLS ACCESSORIES
- HAND TOOLS / COMBINATION SETS

HSS-G metal drill bit

- Ground point drill bits suitable for ferrous and non-ferrous metals, offering good drilling speeds and extended working life.
- Available in 1.5mm - 13mm in multipacks.
- Multipack Ground Point HSS drills
1.5mm - 8mm : 10pc pack
8.25mm - 13mm : 5pc pack



Bit Dia (mm)	Overall Length (L1) (mm)	Working Length (L2) (mm)	Per Pkg	Part No
1.50	40	18	10	D-06236
1.75	46	22	10	D-06242
2.0	49	24	10	D-06258
2.25	53	27	10	D-06264
2.50	57	30	10	D-06270
2.75	61	33	10	D-06286
2.90	61	33	10	D-46648
3.0	61	33	10	D-06292
3.20	65	36	10	D-34942
3.25	65	36	10	D-06301
3.30	65	36	10	D-46567
3.50	70	39	10	D-06317
3.75	70	39	10	D-06323
4.0	75	43	10	D-06339
4.20	75	43	10	D-17762
4.25	75	43	10	D-06345
4.50	80	47	10	D-06351
4.75	80	47	10	D-06367
5.0	86	52	10	D-06373
5.20	86	52	10	D-34986
5.25	86	52	10	D-06389
5.30	86	52	10	D-46654
5.50	93	57	10	D-06395
5.75	93	57	10	D-06404
6.0	93	57	10	D-06410
6.25	101	63	10	D-06426
6.50	101	63	10	D-06432
6.75	101	69	10	D-06448
6.80	109	69	10	D-46779
7.0	109	69	10	D-06454
7.25	109	69	10	D-06460
7.50	109	69	10	D-06476
7.75	117	75	10	D-06482
8.0	117	75	10	D-06498
8.25	117	75	5	D-06507
8.50	117	75	5	D-06513
8.75	125	81	5	D-06529
8.80	125	81	5	D-46785
9.0	125	81	5	D-06535
9.25	125	81	5	D-06541
9.50	125	81	5	D-06557
9.75	133	87	5	D-06563
10.0	133	87	5	D-06579
10.3	133	87	5	D-46791
10.5	133	87	5	D-06591
10.8	142	94	5	D-46800
11.0	142	94	5	D-06600
11.5	142	94	5	D-06616
12.0	151	101	5	D-06622
12.5	151	101	5	D-06638
13.0	151	101	5	D-06644

BATTERY / CHARGERS

FIXING FASTENING (SCREWDRIVER BITS / IMPACT SOCKETS)

DRILLING (WOOD / METAL/ MASONRY)

DRILLING / DEMOLITION [CONCRETE]

CUTTING [METAL]

MULTI TOOL ACCESSORIES

DIAMOND [CUTTING / GRINDING]

GRINDING ACCESSORIES

SANDING / POLISHING ACCESSORIES

SAWING ACCESSORIES

ROUTERS / PLANERS ACCESSORIES

CLEANERS ACCESSORIES

HEAT GUN / LASERS ACCESSORIES

BRAD NAILS/ PINS STAPLER

GARDEN TOOLS ACCESSORIES

HAND TOOLS / COMBINATION SETS

- BATTERY / CHARGERS
- FIXING FASTENING (SCREWDRIVER BITS / IMPACT SOCKETS)
- DRILLING (WOOD / METAL / MASONRY)

19 Pcs HSS-G metal drill bit set

- 1 pc each 1.0 to 10.0mm in steps of 0.5mmes)

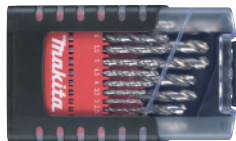

- DRILLING / DEMOLITION [CONCRETE]
- CUTTING [METAL]
- MULTI TOOL ACCESSORIES
- DIAMOND [CUTTING / GRINDING]
- GRINDING ACCESSORIES
- SANDING / POLISHING ACCESSORIES
- SAWING ACCESSORIES
- ROUTERS / PLANERS ACCESSORIES
- CLEANERS ACCESSORIES
- HEAT GUN / LASERS ACCESSORIES
- BRAD NAILS/ PINS STAPLER
- GARDEN TOOLS ACCESSORIES
- HAND TOOLS / COMBINATION SETS

(HSS-G) Double Ended Drill Bit

Double ended drill bits are derivative of HSS-G and both ends are drills

Materials: Same material as HSS-G and fully ground.

Cutting edge: 135° split point geometry which ensures no walking and slipping. The total and working lengths are shorter than other HSS drill bits.

Size: Total 21 sizes from 2.0mm to 10.0mm including 3.1mm, 3.2mm, 3.3mm which are suitable sizes for drilling holes for rivets.

Depth of hole: 30% shorter than HSS-G. Suitable for thin metal sheets because of the length.

Package: Each size 10 pieces a pack.

Application: While drilling many holes on thin metal sheets, double ended drill bits are preferred because of their short length and long life.

Type of industry: Sheet metal work, automotive body shop and maintenance jobs.



Double ended drill bits with angle drill makes very comfortable working at narrow spaces

Bit Dia (mm)	Per Pkg	Part No (With country of origin)
1, 1.5, 2, 2.5, 3, 3.5, 4, 4.5, 5, 5.5, 6, 6.5, 7, 7.5, 8, 8.5, 9, 9.5, 10	Each 1pc	D-50740

Bit Dia (D) (mm)	Overall Length (L1) (mm)	Working Length (L2) (mm)	Per Pkg	Part No	New Part No (With country of origin)
2.0	38	7.5	10	B-26652	B-26864
3.0	46	10.6	10	B-26668	B-26870
3.1	49	11.0	10	B-26674	-
3.2	49	11.0	10	B-26680	-
3.3	49	11.0	10	B-26696	-
3.5	52	13.0	10	B-26705	B-26917
3.8	55	14.0	10	B-26711	-
4.0	55	14.0	10	-	B-26939
4.1	55	14.0	10	B-26733	B-26945
4.2	55	14.0	10	B-26749	-
4.3	55	14.0	10	B-26755	-
4.5	58	16.0	10	B-26761	B-26973
4.8	62	17.0	10	B-26777	-
4.9	62	17.0	10	B-26783	-
5.0	62	17.0	10	B-26799	B-27006
5.1	62	17.0	10	B-26808	-
5.2	62	17.0	10	B-26814	-
5.5	66	19.0	10	B-26820	-
6.0	66	19.0	10	B-26836	B-27040
8.0	79	25.0	10	B-26842	-
10.0	89	25.0	10	B-26858	-



HSS Co-Metal drill bit

- HSS drill bits with 5% cobalt content for easy drilling of high alloy or high tensile steels.
- Body ground for further accuracy and to reduce resistance.
- Use on mild, stainless and high alloy steels and difficult to machine materials, welded seams and car body work.
- Ideal for stainless steel and cast iron.



Bit Dia (D) (mm)	Overall Length (L1) (mm)	Working Length (L2) (mm)	Per Pkg	Part No
2.0	49	24	5	D-16623
2.5	57	30	5	D-16639
3.0	61	33	5	D-16645
3.5	70	39	5	D-16667
4.0	75	43	5	D-16673
4.5	80	47	5	D-16689
5.0	86	52	5	D-16695
5.5	93	57	5	D-16704
6.0	93	57	5	D-16710
6.5	101	63	5	D-16726
7.0	109	69	5	D-16732
7.5	109	69	5	D-16748
8.0	117	75	5	D-16754
8.5	117	75	5	D-16760
9.0	125	81	5	D-16776
9.5	125	81	5	D-16782
10.0	133	87	5	D-16798
10.5	133	87	5	D-16807
11.0	142	94	5	D-16813
11.5	142	94	5	D-16829
12.0	151	101	5	D-16835
12.5	151	101	5	D-16841
13.0	151	101	5	D-16857

- BATTERY / CHARGERS
- FIXING FASTENING (SCREWDRIVER BITS / IMPACT SOCKETS)
- DRILLING (WOOD / METAL/ MASONRY)
- DRILLING / DEMOLITION [CONCRETE]
- CUTTING [METAL]
- MULTI TOOL ACCESSORIES
- DIAMOND [CUTTING / GRINDING]
- GRINDING ACCESSORIES
- SANDING / POLISHING ACCESSORIES
- SAWING ACCESSORIES
- ROUTERS / PLANERS ACCESSORIES
- CLEANERS ACCESSORIES
- HEAT GUN / LASERS ACCESSORIES
- BRAD NAILS/ PINS STAPLER
- GARDEN TOOLS ACCESSORIES
- HAND TOOLS / COMBINATION SETS

6 Pcs HSS-Co metal drill set

Type: Straight (Cylindrical)



Bit Dia (mm)	Per Pkg	Part No
2 x 24mm 3 x 33mm 4 x 43mm 5 x 52mm 6 x 57mm 8 x 75mm	Each 1pc	D-57168

- BATTERY / CHARGERS
- FIXING FASTENING (SCREWDRIVER BITS / IMPACT SOCKETS)
- DRILLING (WOOD / METAL / MASONRY)
- DRILLING / DEMOLITION [CONCRETE]
- CUTTING [METAL]
- MULTI TOOL ACCESSORIES
- DIAMOND [CUTTING / GRINDING]
- GRINDING ACCESSORIES
- SANDING / POLISHING ACCESSORIES
- SAWING ACCESSORIES
- ROUTERS / PLANERS ACCESSORIES
- CLEANERS ACCESSORIES
- HEAT GUN / LASERS ACCESSORIES
- BRAD NAILS/ PINS STAPLER
- GARDEN TOOLS ACCESSORIES
- HAND TOOLS / COMBINATION SETS

HSS-Tin Metal Economy Drill Bits

- The bits surface is coated with Titanium Nitride which is extremely hard and highly wear-resistant, therefore enhances the quality and extends the life of the product.
- The Drill bit tip has a 135° split point geometry which ensures that there is no walking and slipping during operation.
- Available in various sizes from 2.0mm to 13mm and are sold at packs of 5 and 10 pcs.

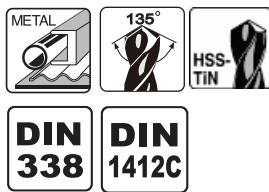

Bit Dia (D) (mm)	Overall Length (L1) (mm)	Working Length (L2) (mm)	Per Pkg	Part No
2.0	49	24	10	D-64272
2.5	57	30	10	D-64288
3.0	61	33	10	D-64294
3.5	70	39	10	D-64303
4.0	75	43	10	D-64319
4.5	80	47	10	D-64325
5.0	86	52	10	D-64331
5.5	93	57	10	D-64347
6.0	93	57	10	D-64353
6.5	101	63	10	D-64369
7.0	109	69	10	D-64375
8.0	117	75	10	D-64397
8.5	117	75	5	D-64406
9.0	125	81	5	D-64412
9.5	125	81	5	D-64428
10.0	133	87	5	D-64434
10.5	133	87	5	NEW D-64440
11.0	142	94	5	D-64456
12.0	151	101	5	D-64478
12.5	151	101	5	D-64484
13	151	101	5	NEW D-64490

19pcs HSS-Tin Metal Economy Drill Bits

Comes as 10pcs set



Plastic Case



Drill holder will stand automatically when the case opened. Drill bits can be take out easily

x10



10pcs set comes in a counter display carton box

Size (mm)	Pkg	Country of origin	Part No
1pc each of 1, 1.5, 2, 2.5, 3, 3.5, 4, 4.5, 5, 5.5, 6, 6.5, 7, 7.5, 8, 8.5, 9., 9.5, 10	10pcs set	Yes	D-72229-10

HSS-TiN Impact Drill Bit with 1/4" Hex. shank

- It is easy to mount and apply the 1/4 Hex Shank to the Impact Driver.
- It has a 135deg split point to avoid drill walking while drilling.
- Realized great durability applying TiN coating which is superior in heat and wear resistance.



Bit diameter (mm)	Length (mm)	Working length (mm)	Pc/ Pkg	Part No (WITH COUNTRY OF ORIGIN)
3	64	26	1	B-51085
3.5	70	29	1	B-51116
4	71	30	1	B-51122
6	80	37	1	B-51172
10	102	50	1	B-51247

BATTERY / CHARGERS

FIXING FASTENING (SCREWDRIVER BITS / IMPACT SOCKETS)

DRILLING (WOOD / METAL/ MASONRY)

DRILLING / DEMOLITION [CONCRETE]

CUTTING [METAL]

MULTI TOOL ACCESSORIES

DIAMOND [CUTTING / GRINDING]

GRINDING ACCESSORIES

SANDING / POLISHING ACCESSORIES

SAWING ACCESSORIES

ROUTERS / PLANERS ACCESSORIES

CLEANERS ACCESSORIES

HEAT GUN / LASERS ACCESSORIES

BRAD NAILS/ PINS STAPLER

GARDEN TOOLS ACCESSORIES

HAND TOOLS / COMBINATION SETS

HSS-TiN Metal Drill Bit For SDS-PLUS Hammers

Fully ground HSS drill bit



Adapted for SDS-PLUS Rotary Hammers

Can be used on SDS PLUS Hammers to drill metal sheet without the need of having an additional chuck.



Bit Dia (mm)	Overall Length (mm)	Working Length (mm)	Per Pkg	Part No
3	90	33	1	B-57401
3.5	100	39	1	B-57417
4	105	43	1	B-57423
4.5	110	47	1	B-57439
5	116	52	1	B-57445
6	123	57	1	B-57467

HSS Drill Bit - Titanium coated with Hex. shank

For use with 3 Jaw & Maklok chucks and 1/4" Hex drive tools



	Size (mm)	Pc/ Pkg	Part No
	1.5	1	P-51611
	2	1	P-51661
	3	1	P-51677
	3.2	1	P-51627
	5	1	P-51633

16pcs HSS Drill Bit - Titanium coated

For use with 3 Jaw chucks With plastic case



Size (mm)	Pc/ Pkg	Part No
1.5, 2, 2.5, 3, 3.2, 3.5, 4, 4.5, 5, 5.5, 6, 6.5, 7, 8, 10	each 1 pc	P-51873

BATTERY / CHARGERS

FIXING FASTENING (SCREWDRIVER BITS / IMPACT SOCKETS)

DRILLING (WOOD / METAL/ MASONRY)

DRILLING / DEMOLITION [CONCRETE]

CUTTING [METAL]

MULTI TOOL ACCESSORIES

DIAMOND [CUTTING / GRINDING]

GRINDING ACCESSORIES

SANDING / POLISHING ACCESSORIES

SAWING ACCESSORIES

ROUTERS / PLANERS ACCESSORIES

CLEANERS ACCESSORIES

HEAT GUN / LASERS ACCESSORIES

BRAD NAILS/ PINS STAPLER

GARDEN TOOLS ACCESSORIES

HAND TOOLS / COMBINATION SETS

Straight shank (Masonry drill bit)

- Straight shank tungsten carbide-tipped masonry drill bit



Bit Dia (D) (mm)	Overall Length (L1) (mm)	Working Length (L2)(mm)	Per Pkg	Part No	New Part No (With country of origin)
3	60	30	1	-	D-05393
4	70	35	1	-	D-05402
5	85	45	1	-	D-05418
6	100	60	1	-	D-05424
6	150	90	1	-	D-05430
7	100	55	1	-	D-05446
7	150	90	1	-	D-05452
8	110	60	1	-	D-05468
8	150	90	1	-	D-05474
9	150	90	1	-	D-05480
10	150	90	1	-	D-05496
11	150	90	1	D-05337	D-05505
12	150	90	1	-	D-05511
13	150	85	1	-	D-05527
14	150	85	1	-	D-05533
15	150	85	1	D-05371	D-05549
16	150	85	1	-	D-05555

Long straight shank (Masonry drill bit)

- Straight shank tungsten carbide-tipped masonry drill bit
- Ideal for application where deeper holes are required

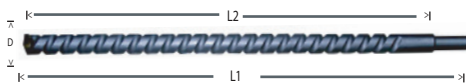

Bit Dia (D) (mm)	Overall Length (L1) (mm)	Working Length (L2)(mm)	Per Pkg	Part No
12	400	315	1	D-17697
12	600	505	1	D-17728
16	400	315	1	D-17706
16	600	505	1	D-17734
20	400	315	1	D-17712
20	600	505	1	D-17740

4 pcs straight shank (Masonry drill bit)



Bit Dia (mm)	Overall Length (mm)	Working Length (mm)	Per Pkg	Part No
5	85	-	1	P-10182
6	100	-	2	
8	120	-	1	

5 pcs straight shank (Masonry drill bit)



Bit Dia (mm)	Overall Length (mm)	Working Length (mm)	Per Pkg	Part No
4	85	50	5	P-35520
5	85	50	5	P-35536
6	100	60	5	P-35242
8	120	-	5	P-35558
10	120	80	5	P-35564
12	150	-	5	P-35570

5 pcs straight shank
(Masonry drill bit)



Bit Dia (mm)	Overall Length (mm)	Working Length (mm)	Per Pkg	Part No
7	100	55	5	D-16508
8	110	60	5	D-16514

BATTERY / CHARGERS

FIXING FASTENING (SCREWDRIVER BITS / IMPACT SOCKETS)

5 pcs straight shank
(Masonry drill bit)



Type	length (mm)	Pc/ Pkg	Part No	New Part No (With country of origin)
4	70	1	D-05175	D-03894
5	85	1		
6	100	1		
8	100	1		
10	100	1		

DRILLING (WOOD / METAL/ MASONRY)

DRILLING / DEMOLITION [CONCRETE]

CUTTING [METAL]

8 pcs straight shank
(Masonry drill bit)



Bit Dia (mm)	Overall Length (mm)	Working Length (mm)	Per Pkg	Part No
3	70	-	1	P-35514
4	85	-	1	
5	85	-	1	
6	100	-	1	
7	100	-	1	
8	120	-	1	
9	120	-	1	
10	120	-	1	

MULTI TOOL ACCESSORIES

DIAMOND [CUTTING / GRINDING]

GRINDING ACCESSORIES

SANDING / POLISHING ACCESSORIES

13 pcs Masonry Drill Bits

For use with 3 Jaw chucks
With plastic case



Size (mm)	Overall Length (mm)	Working Length (mm)	Per Pkg	Part No
4	-	-	1	P-51889
5	-	-	1	
5.5	-	-	3	
6	-	-	2	
6.5	-	-	2	
7	-	-	2	
8	-	-	2	

SAWING ACCESSORIES

ROUTERS / PLANERS ACCESSORIES

CLEANERS ACCESSORIES

HEAT GUN / LASERS ACCESSORIES

Masonry Drill Bits

For use with 3 Jaw & Maklok chucks
and 1/4" Hex drive tools



Size (mm)	Overall Length (mm)	Working Length (mm)	Per Pkg	Part No
4	-	-	1	P-51758
5	-	-	1	P-51764
5.5	-	-	1	P-51770
6	-	-	1	P-51786
6.5	-	-	1	P-51792
7	-	-	1	P-51801
8	-	-	1	P-51817

BRAD NAILS/ PINS STAPLER

GARDEN TOOLS ACCESSORIES

HAND TOOLS / COMBINATION SETS

BIM Hole saw (Standard range)

- Hole saws have 4/6 vari-pitch tooth design
- Recommended for cutting steel and cast iron pipe plates, aluminum copper and brass.



Size (mm)	Standard range
14	D-35368
16	D-16994
17	D-35374
19	D-17005
20	D-17251
21	D-35380
22	D-17011
24	D-17027
25	D-17033
27	D-35396
29	D-17267
30	D-35405
32	D-17049
33	D-35411
35	D-17055
37	D-35427
38	D-17061

Size (mm)	Standard range
40	D-17273
41	D-35433
43	D-35449
44	D-17077
46	D-35455
48	D-35461
51	D-17083
52	D-35477
56	D-35483
57	D-17099
59	D-35499
67	D-35508
68	D-17108
73	D-35514
76	D-17114
79	D-35520
83	D-17120

Size (mm)	Standard range
86	D-35536
89	D-35542
92	D-17136
95	D-35558
98	D-35564
102	D-35570
105	D-17142
108	D-35586
111	D-35592
114	D-35601
121	D-35617
127	D-17158
140	D-35623
152 (Premium Range)	P-35106

Mandrel and pilot drill (for Hole saw)



Type	Fits Hole saws	Premium range Part no	Standard range Part no
Mandrel with Pilot Drill			
For 10mm Drill	14-29mm		D-17170
For 13mm Drill	32-152mm		D-17186
For SDS-PLUS	14-29mm		D-17603
For SDS-PLUS	32-76mm		D-17619
Mandrel quick change system			
For SDS-PLUS	32-210mm	P-35190	

Pilot Drill			
102mm long		P-35215	
71mm long	All		D-17192

Hole saw (Assorted)

Six most common sizes for Plumber & Electrician. Comes in plastic carry case



Size (mm)	Part No.
19,22,29,38,44,57mm	D-16938 / D-47117
16,20,25,32,40,51mm	D-16944

BATTERY / CHARGERS

FIXING FASTENING (SCREWDRIVER BITS / IMPACT SOCKETS)

DRILLING (WOOD / METAL/ MASONRY)

DRILLING / DEMOLITION (CONCRETE)

CUTTING (METAL)

MULTI TOOL ACCESSORIES

DIAMOND (CUTTING / GRINDING)

GRINDING ACCESSORIES

SANDING / POLISHING ACCESSORIES

SAWING ACCESSORIES

ROUTERS / PLANERS ACCESSORIES

CLEANERS ACCESSORIES

HEAT GUN / LASERS ACCESSORIES

BRAD NAILS/ PINS STAPLER

GARDEN TOOLS ACCESSORIES

HAND TOOLS / COMBINATION SETS

- BATTERY / CHARGERS
- FIXING FASTENING (SCREWDRIVER BITS / IMPACT SOCKETS)
- DRILLING (WOOD / METAL/ MASONRY)
- DRILLING / DEMOLITION [CONCRETE]
- CUTTING [METAL]
- MULTI TOOL ACCESSORIES
- DIAMOND [CUTTING / GRINDING]
- GRINDING ACCESSORIES
- SANDING / POLISHING ACCESSORIES
- SAWING ACCESSORIES
- ROUTERS / PLANERS ACCESSORIES
- CLEANERS ACCESSORIES
- HEAT GUN / LASERS ACCESSORIES
- BRAD NAILS/ PINS STAPLER
- GARDEN TOOLS ACCESSORIES
- HAND TOOLS / COMBINATION SETS

BIM Hole saw for sheet metal (Premium range)

- Heavy duty
- Cutting capacity thickness for metal is 0.8-5mm and for stainless is 0.8-2mm
- Longer life due to Bi-Metal with 8% Cobalt

The stopper absorbs the impact when hole saw goes through the materials



Its very easy to take out a piece of sheet metal due to ejector spring

High quality Bi-metal with 8% Cobalt

Size (mm)	Part no
16	B-29670
19	B-29692
20	B-29701
22	B-29723
25	B-29739
29	B-29751
32	B-29773
35	B-29795

Size (mm)	Part no
38	B-29804
40	B-29810
51	B-29854
60	B-29882
64	B-29898
65	B-35994
68	B-36011
70	B-36027

Size (mm)	Part no
76	B-36049
83	B-36061
89	B-36083
102	B-36099
127	B-36108
152	B-36114

Mandrel and pilot drill (For hole saw)

New Mandrel for ϕ 38-152mm Hole saw size



Adapter with O ring

Type	Fits Hole saws	With Pilot drill	Part no
Mandrel with Pilot Drill			
For 10mm Drill	16-35mm	HSS6542	B-36120
For 13mm Drill	38-152mm	HSS6542	B-36136

Pilot Drill

60mm long	All		B-36142
-----------	-----	--	----------------

Hole saw for sheet metal (Assorted)

Six most common sizes for Plumber & Electrician.



9.5/11mm Adapters with 1pcs of pilot drill

Size (mm)	Part No.
20,25,32,38,51,64mm	B-38679
19,22,29,38,44,57mm	B-38663

How to use mandrel



Pull down the silver part and hold it



Adjust positions pins and put them into the hole saw

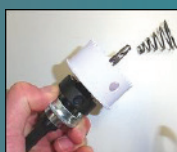

Fasten a hole saw to the adapter



Attach the spring

Vacuum Brazed Diamond Hole Saw



- Can drill holes for various materials
- Thick wall and brick can be run through less efforts and less working time to drill holes

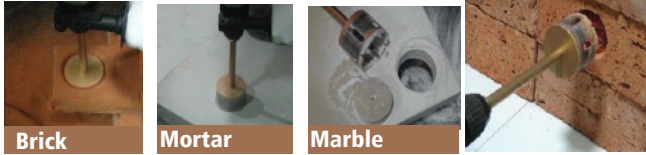

For Machine: 10 - 13mm Drill
Hole Saw: Material of Tip: Diamond
Material of Body: Carbon Steel
Centre Drill Bit: Material fo Tip: Tungsten Carbide
Angle of Tip: 135deg / Use by driver mode
Extension Rod: 150mm Straight Shank for Hole Saw of all sizes
RPM: 16mm-64mm, 3000-500rpm

Diamond wet Hole Saw For Hard Ceramics



- Suitable in wet drilling application
- Recommended to use with DC drills to work on hard ceramics with water
- Diamond Grit for faster cutting and longer life even on hard materials
- Easy centering on hard ceramic - These hole saws come with Spring-Loaded, Retractable Shaft pilot bit.



Retractable Starter Pilot Bit

Bit Dia (mm)	Working Length (mm)	Part no
16	40	B-45870
19	40	B-45886
25	40	B-45892
30	40	B-45901
32	40	B-45917
35	40	B-45923
38	40	B-45939
45	40	B-45945
50	40	B-45951
53	40	B-45967
57	40	B-45973
64	40	B-45989

Size (mm)	Part no
19	D-61210
20	D-61226
22	D-61232
25	D-61248
29	D-61254
32	D-61260
35	D-61276
38	D-61282
41	D-61298
44	D-61307
51	D-61313
54	D-61329
57	D-61335
60	D-61341
64	D-61357
65	D-61363
67	D-61379
68	D-61385
70	D-61391
76	D-61400
79	D-61416
83	D-61422
(Adapter 9.5mm Hex (for 19-29mm Holesaw	D-61438
(Adapter 11mm Hex (for 32-83mm Holesaw	D-61444
Retractable Starter Pilot Bit	D-61450

BATTERY / CHARGERS
FIXING FASTENING (SCREWDRIVER BITS / IMPACT SOCKETS)
DRILLING (WOOD / METAL/ MASONRY)
DRILLING / DEMOLITION [CONCRETE]
CUTTING [METAL]
MULTI TOOL ACCESSORIES
DIAMOND [CUTTING / GRINDING]
GRINDING ACCESSORIES
SANDING / POLISHING ACCESSORIES
SAWING ACCESSORIES
ROUTERS / PLANERS ACCESSORIES
CLEANERS ACCESSORIES
HEAT GUN / LASERS ACCESSORIES
BRAD NAILS/ PINS STAPLER
GARDEN TOOLS ACCESSORIES
HAND TOOLS / COMBINATION SETS

BATTERY / CHARGERS

FIXING FASTENING (SCREWDRIVER BITS / IMPACT SOCKETS)

DRILLING (WOOD / METAL/ MASONRY)

DRILLING / DEMOLITION [CONCRETE]

CUTTING [METAL]

MULTI TOOL ACCESSORIES

DIAMOND [CUTTING / GRINDING]

GRINDING ACCESSORIES

SANDING / POLISHING ACCESSORIES

SAWING ACCESSORIES

ROUTERS / PLANERS ACCESSORIES

CLEANERS ACCESSORIES

HEAT GUN / LASERS ACCESSORIES

BRAD NAILS/ PINS STAPLER

GARDEN TOOLS ACCESSORIES

HAND TOOLS / COMBINATION SETS

Diamond Wet Core Cutters

For Model: DBM131/DBM230 (Diamond Core Drill)

Material: These can be used for soft, hard and reinforced concrete.

Features: Fast starting , Easy centering, Low friction and Time saving

Connection thread: 1 1/4" UNC

- Fast Starting
- Easy Centering
- Low Friction
- Time Saving

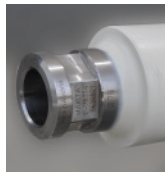

Core bit (Fitting)



Core bit



Outer Dia (mm)	Length (mm)	Part No.
32	420	P-65953
42	420	P-78330
52	420	P-78346
62	420	P-65969
65	420	P-78352
72	420	P-78368
78	420	P-78374
82	420	P-65975
92	420	P-78380
102	420	P-65981
107	420	P-78396
112	420	P-78405
122	420	P-65997
127	420	P-78411
132	420	P-66008
152	420	P-66014
162	420	P-66020
202	420	P-66036
225	420	P-66042

Accessories for Core Cutters

Diamond core cutter - Steel Hex Extension Bar

Female 1 1/4" UNC to Male 1 1/4" UNC



DBM230 can be directly attached to cutter.

DBM131 can be connected to the cutter using Adapter M18 (Part No. P-42151)



For model	Length (mm)	Part No.
DBM131, DBM230	100mm	P-41604
	300mm	P-41626

Oil for Diamond Core Drill Machine

Oil for DBM230 (Diamond Core Drill)



		Part No.
1000ml	PE150	EE7100036

Diamond Core Cutters

- To be used with the Drill Chuck System
- For Model: 8419B-2, 8420, HP2000, HP2010N, HP2050/F, HP2070
- Note: Use core cutters only with rotary mode.



Diameter (mm)	Effective Length (mm)	Part No.
22	300	P-25535
28	300	P-25541

DRY Drilling Core cutters (PRB7 Slotted body)

- A: 13MM Drill Chucks - Used with P-34562 Adapter
- B: HR1830,HR2460, HR2470 - Used with P-30031 Adapter
- C: HR3000C - Used with P-30031 Adapter
- D: DBM131 - Used with P-49286 Adapter











PRB7 Core Bit (Fitting)

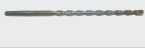

PRB7 Core Bit

For model	Diameter (mm)	Effective Length (mm)	Part No.
A, B, C, D	32	150	P-44731
A, B, C, D	38	150	P-25557
A, B, C, D	48	150	P-25563
A, B, C, D	52	150	P-25579
B, C, D	65	150	P-25585
C, D	78	150	P-25591
C, D	91	150	P-25600
D	107	150	P-25616
D	117	150	P-25622
D	127	150	P-25638
D	152	150	P-25644
D	162	150	P-44753

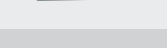
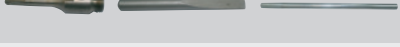
Accessories for Dry Core Drills

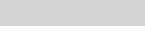
Type / For model	Part No.
 1/2" BSP male For 13mm Chuck Adapter	P-34562
 SDS Plus chuck adaptor- R½ For models: HR1830, HR2460, HR2470, HR2432, HR3000C	P-30031
 ½" BSP Male For Model DBM131	P-49286
 Drift Key (to remove pilot drill)	P-34752
 10mm Pilot Drill A Taper	P-34724
 Guide Rod	P-34746
 Spring Point Guide A Taper	P-49301
 Adaptor Pack- SDS Plus (Chuck Adapter, Guide Rod, Drift Key)	P-34730
 Barrel Extension 100mm R½	P-41551
 Barrel Extension 300mm R½	P-34718

BATTERY / CHARGERS

FIXING FASTENING (SCREWDRIVER BITS / IMPACT SOCKETS)

DRILLING (WOOD / METAL/ MASONRY)

DRILLING / DEMOLITION [CONCRETE]

CUTTING [METAL]

MULTI TOOL ACCESSORIES

DIAMOND [CUTTING / GRINDING]

GRINDING ACCESSORIES

SANDING / POLISHING ACCESSORIES

SAWING ACCESSORIES

ROUTERS / PLANERS ACCESSORIES

CLEANERS ACCESSORIES

HEAT GUN / LASERS ACCESSORIES

BRAD NAILS/ PINS STAPLER

GARDEN TOOLS ACCESSORIES

HAND TOOLS / COMBINATION SETS

- BATTERY / CHARGERS
- FIXING FASTENING (SCREWDRIVER BITS / IMPACT SOCKETS)
- DRILLING (WOOD / METAL / MASONRY)
- DRILLING / DEMOLITION [CONCRETE]
- CUTTING [METAL]
- MULTI TOOL ACCESSORIES
- DIAMOND [CUTTING / GRINDING]
- GRINDING ACCESSORIES
- SANDING / POLISHING ACCESSORIES
- SAWING ACCESSORIES
- ROUTERS / PLANERS ACCESSORIES
- CLEANERS ACCESSORIES
- HEAT GUN / LASERS ACCESSORIES
- BRAD NAILS/ PINS STAPLER
- GARDEN TOOLS ACCESSORIES
- HAND TOOLS / COMBINATION SETS

Broach cutter for magnetic drilling machine



Short = 25mm Depth		Long = 50mm Depth	
Diameter	Part No.	Diameter	Part No.
12mm Short	(MM)12S	12mm Long	(MM)12L
13mm Short	(MM)13S	13mm Long	(MM)13L
14mm Short	(MM)14S	14mm Long	(MM)14L
15mm Short	(MM)15S	15mm Long	(MM)15L
16mm Short	(MM)16S	16mm Long	(MM)16L
17mm Short	(MM)17S	17mm Long	(MM)17L
18mm Short	(MM)18S	18mm Long	(MM)18L
19mm Short	(MM)19S	19mm Long	(MM)19L
20mm Short	(MM)20S	20mm Long	(MM)20L
21mm Short	(MM)21S	21mm Long	(MM)21L
22mm Short	(MM)22S	22mm Long	(MM)22L
23mm Short	(MM)23S	23mm Long	(MM)23L
24mm Short	(MM)24S	24mm Long	(MM)24L
25mm Short	(MM)25S	25mm Long	(MM)25L
26mm Short	(MM)26S	26mm Long	(MM)26L
27mm Short	(MM)27S	27mm Long	(MM)27L
28mm Short	(MM)28S	28mm Long	(MM)28L
29mm Short	(MM)29S	29mm Long	(MM)29L
30mm Short	(MM)30S	30mm Long	(MM)30L
31mm Short	(MM)31S	31mm Long	(MM)31L
32mm Short	(MM)32S	32mm Long	(MM)32L
33mm Short	(MM)33S	33mm Long	(MM)33L
34mm Short	(MM)34S	34mm Long	(MM)34L
35mm Short	(MM)35S	35mm Long	(MM)35L
36mm Short	(MM)36S	36mm Long	(MM)36L
37mm Short	(MM)37S	37mm Long	(MM)37L
38mm Short	(MM)38S	38mm Long	(MM)38L
39mm Short	(MM)39S	39mm Long	(MM)39L
40mm Short	(MM)40S	40mm Long	(MM)40L
41mm Short	(MM)41S	41mm Long	(MM)41L
42mm Short	(MM)42S	42mm Long	(MM)42L
43mm Short	(MM)43S	43mm Long	(MM)43L
44mm Short	(MM)44S	44mm Long	(MM)44L
45mm Short	(MM)45S	45mm Long	(MM)45L
46mm Short	(MM)46S	46mm Long	(MM)46L
47mm Short	(MM)47S	47mm Long	(MM)47L
48mm Short	(MM)48S	48mm Long	(MM)48L
49mm Short	(MM)49S	49mm Long	(MM)49L
50mm Short	(MM)50S	50mm Long	(MM)50L

Broach cutter pilot pin



Pilot pin small (mm)Pilot-S-25

Pilot Pin large (mm)Pilot-L-50

Pilot Pin	Part No.
25mm	(MM)PILOT S
50mm	(MM)PILOT L

Chuck adapter for broach cutter



For use with	Part No.
For MM32 only	MMCHU03

Cutting Oil for HB500 (Electro Magnetic Drill Press)









500ml	Part No.
	MMOIL02



1 Litre Empty Container

Mixing blade for Mixer

Mixing blade for model UT1400 / UT120							
	Materials	Mixing Effect	Diameter	Mixing Quantity	Shaft	Total Length	Part No.
	Thin, light and fluid materials, such as colours, base, sludges	Top to bottom	120 mm	16 - 30 kg	M14	590 mm	P-22012
The steep set wings produce a high level of cutting power for paints and liquid materials. Prevents the formation of lumps. Especially designed for continuous masses.							
	Sticky and viscous materials, such as mortar, plasters	Bottom to top	120 mm	10 - 15 kg	M14	590 mm	P-22028
Very good movement of material from bottom to top, flat helix places less demand on user and machine.							
	Sticky and viscous materials, such as mortar, plasters	Bottom to top	135 mm	15 - 30 kg	M14	590 mm	P-22040
Very good movement of material from bottom to top, flat helix places less demand on user and machine.							
	Thin, light and fluid materials, such as colours, base, sludges	Top to bottom	120 mm	10 - 25 kg	M14	590 mm	P-22056
Uses three mixing blades to compress the material from top to bottom, no splashes, but increased machine demands, therefore it is especially suited to fluid and fibrous materials, or fine, creamy, plasters. Prevents the formation of lumps.							

Mixing blade for model DUT130 / UT1305 / UT2204													
Shape	Dia	Material	Part #	Specs	Type	With Bolt	Twin Blade	Bolt		Shaft			For Model
								Size	Part #	Thread	Size	Part #	
	130 mm	INOX	A-43670	Low load to motor due to small diameter	A			M8 x 18	265220-5	M12	L=584mm D=12mm	321086-4	DUT130 UT1305
	135 mm	Aluminium	A-43723	The blade angle is narrow. For heavy mixing material such as concrete	B	✓		W5/16 x 16	265475-2	M12	L=584mm D=12mm	A-43773	DUT130 UT1305 UT2204
	150 mm	INOX	A-43686	The blade is upward and has the ring around it. This can decrease kickback when hitting to side or bottom of vessel	A			---	---	M12	L=584mm D=12mm	321086-4	DUT130 UT1305 UT2204
	165 mm	INOX	A-43692	Four big holes can be can make easy for moving up and down	A	✓		M8 x 18	265220-5	M12	L=584mm D=12mm	321086-4	DUT130 UT1305
	175 mm	Aluminium	A-43701	Less wearing and long life	B	✓	✓	W5/16 x 16	265475-2	M12	L=584mm D=12mm	A-43773	UT1305 UT2204
	183mm	Aluminium	A-43739	The blade angle is narrow. For heavy mixing material such as concrete	B	✓	✓	W5/16 x 16	265475-2	M12	L=584mm D=12mm	A-43773	UT1305 UT2204
	190mm	Steel	A-33065	For two blades. Less wearing and long life	B	✓	✓	W5/16 x 16	265475-2	M12	L=584mm D=12mm	A-43773	UT2204
	200mm	-	A-43745	Less wearing and long life	B	✓		Thread Type	-	M12	L=584mm D=12mm	A-43773	UT2204
	201mm	Steel	A-33071	For two blades (as twice as mixing ability). Light due to aluminium	B	✓	✓	W5/16 x 16	265475-2	M12	L=584mm D=12mm	A-43773	UT2204
	220mm	Aluminium	A-43717	Big diameter and mixing widely. light due to aluminium	B	✓		M8 x 16	265440-1	M12	L=584mm D=12mm	A-43773	UT2204

A: Mixing low viscosity materials such as paints.
 B: Mixing for high viscosity materials such as mortar or Plaster/

BATTERY / CHARGERS

FIXING FASTENING (SCREWDRIVER BITS / IMPACT SOCKETS)

DRILLING (WOOD / METAL/ MASONRY)

DRILLING / DEMOLITION [CONCRETE]

CUTTING [METAL]

MULTI TOOL ACCESSORIES

DIAMOND [CUTTING / GRINDING]

GRINDING ACCESSORIES

SANDING / POLISHING ACCESSORIES

SAWING ACCESSORIES

ROUTERS / PLANERS ACCESSORIES

CLEANERS ACCESSORIES

HEAT GUN / LASERS ACCESSORIES

BRAD NAILS/ PINS STAPLER

GARDEN TOOLS ACCESSORIES

HAND TOOLS / COMBINATION SETS

BATTERY / CHARGERS

FIXING FASTENING (SCREWDRIVER BITS / IMPACT SOCKETS)

DRILLING (WOOD / METAL / MASONRY)

DRILLING / DEMOLITION [CONCRETE]

CUTTING [METAL]

MULTI TOOL ACCESSORIES

DIAMOND [CUTTING / GRINDING]

GRINDING ACCESSORIES

SANDING / POLISHING ACCESSORIES

SAWING ACCESSORIES

ROUTERS / PLANERS ACCESSORIES

CLEANERS ACCESSORIES

HEAT GUN / LASERS ACCESSORIES

BRAD NAILS/ PINS STAPLER

GARDEN TOOLS ACCESSORIES

HAND TOOLS / COMBINATION SETS

Diamond Drill Stand (DBM131)

This stand is used when drilling holes larger than 70mm. But it is advisable to use at all times to avoid core bit and machine damage. (For DBM131)

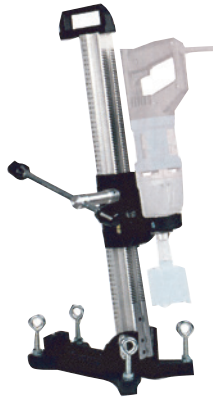

Description	Part No.
Diamond Drill Stand (For DBM131)	P-40082

Diamond Drill Stand (DBM230)

This stand is to be used for All applications. (For DBM230)



Description	Part No.
Diamond Drill Stand (For DBM230)	P-54190

Vise (For TB131)

This stand is to be used for model TB131

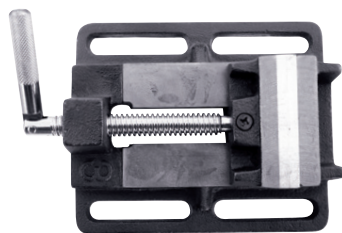

Description	Part No.
Vise (For TB131)	(TB)KK00000100

Type 43 Drill Stand

This stand is to be used for models with neck diameter 43mm



Description	Part No.
Type 43 Drill Stand	A-36712

Anchor Systems for Diamond Drill Stand

For DBM131 / DBM230

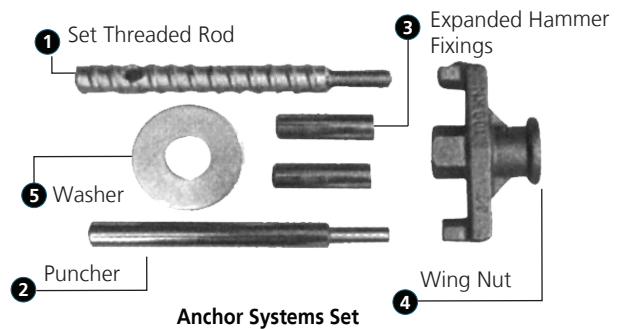

Description	Type	Part No.
Anchor System Set	Includes 1,2,3,4 and 5	P-40098
Threaded Rod	1	P-41735
Puncher	2	P-40288
Expanded fixing	3	P-41741
Wing Nut	4	P-41713
Washer	5	Washer will not be available separately. It will be included with the anchor system set

Drill a 15mm hole, fix the expanded hammer fixing, and set the threaded rod as shown below, place the stand then attach washer and nut (wing nut)

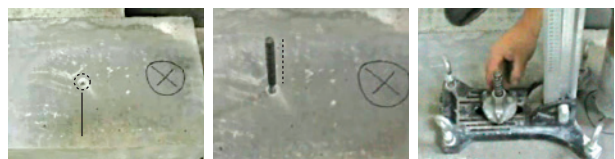

Expanded hammer fixing

Threaded rod

Drill chuck and chuck key



For Model	Capacity (mm)	Thread size	Single Part #	Bulk Part #	Chuck Key
DF0300, HP0300	1.0-10	1/2-20 UNF		766012-0	KEYLESS
650, DP2010	6.5	3/8-24 UNF	192887-5		763418-3
6010B, 6010BVR		3/8" - 24UNF	192970-8	763418-3	763418-3
6408	0.8-10	3/8-24 UNF	192016-0	763132-1	KEYLESS
6413	0.8-10	3/8-24 UNF		763242-4	KEYLESS
6300-4, 6305, DP4700, DS4011, 8419B 8419B 8416, 8420V, HP2000, HP2010N, HP20: HP2050, HP2070	2.0-13	1/2-20 UNF	192877-8		763432-9
6300-4, 6301, 6305, DA4000LR, DP4700, DS4011, DS5000, 8416, HP2000 HP2010N, HP2070, NHP1300S, NHP1320S	4.5-16	1/2-20 UNF		763066-8	763432-9
6016	16	(jacob staper No.3)		763011-3	763429-8
DA3010, DDA350				763174-5	763415-9
6408, DA392DW			192016-0		KEYLESS
TB131				(TB)KK00000060	(TB)KK00000061
HP1230	1.5-10	3/8" - 24UNF	192879-4		763415-9
HP1631K			196193-0	766017-0	KEYLESS
HP1630K, HP1640K			196008-1	766016-2	763448-4
DA4000LR, 6304LR			193318-7		763432-9
DP4010, HP2050			193067-6		763440-0
DA3000			193442-6	763068-4	763414-1
6080B			763003-2		KEYLESS
DF001G, DHP481, DDF481	1.5-13	1/2-20 UNF		763252-1	KEYLESS
HP001G				136229-3	KEYLESS
DDF481, DHP181	1.5-13	1/2-20 UNF		763248-2	KEYLESS
DDF451, DHP451, DDF441, DHP441	1.5-13	1/2-20 UNF		763196-5 / 763191-5	KEYLESS
DDF482, DDF484, DDF456, DDF459, DF457D, DHP482, DHP484, DHP456, DHP459, HP457D,	1.5-13	1/2-20 UNF		766027-7	KEYLESS
DDF483, DHP483	1.5-13	1/2-20 UNF		763241-6	KEYLESS
DA333D, DF330D, DF331D	0.8-10	3/8-24 UNF		763228-8	KEYLESS
DF332D, DF333D, HP332D, HP333D	0.8-10	3/8-24 UNF		763238-5	KEYLESS
DF347D	0.8-10	1/2-20 UNF		766002-3	KEYLESS
HP330D, HP331D, HP347D	0.8-10	1/2-20 UNF		763229-6	KEYLESS
DDF453, DF457D, DHP453, HP457D	1.5-13	1/2-20 UNF		766004-9	KEYLESS
DA331D	0.8-10	3/8-24 UNF		766007-3	KEYLESS

BATTERY /
CHARGERS

FIXING FASTENING
(SCREWDRIVER BITS
/ IMPACT SOCKETS)

DRILLING
(WOOD / METAL/
MASONRY)

DRILLING
/ DEMOLITION
(CONCRETE)

CUTTING
(METAL)

MULTI TOOL
ACCESSORIES

DIAMOND
(CUTTING / GRINDING)

GRINDING
ACCESSORIES

SANDING
/ POLISHING
ACCESSORIES

SAWING
ACCESSORIES

ROUTERS
/ PLANERS
ACCESSORIES

CLEANERS
ACCESSORIES

HEAT GUN / LASERS
ACCESSORIES

BRAD NAILS / PINS
STAPLER

GARDEN TOOLS
ACCESSORIES

HAND TOOLS /
COMBINATION SETS

BATTERY / CHARGERS

FIXING FASTENING (SCREWDRIVER BITS / IMPACT SOCKETS)

DRILLING (WOOD / METAL/ MASONRY)

DRILLING / DEMOLITION [CONCRETE]

CUTTING [METAL]

MULTI TOOL ACCESSORIES

DIAMOND [CUTTING / GRINDING]

GRINDING ACCESSORIES

SANDING / POLISHING ACCESSORIES

SAWING ACCESSORIES

ROUTERS / PLANERS ACCESSORIES

CLEANERS ACCESSORIES

HEAT GUN / LASERS ACCESSORIES

BRAD NAILS/ PINS STAPLER

GARDEN TOOLS ACCESSORIES

HAND TOOLS / COMBINATION SETS

Locking Keyless Drill Chucks

Makita's unique chuck-lock system prevents the bit from slipping or being overtightened. Chuck snap out to unlock; in to lock.



For Models	Spindle Thread	Part No.
6301, 6013BR, 6300-4, 8416, 8419B, 8419B2, 8420V, DP4700, HP2000, HP2010N, HP2050N, HP2050/F, HP2070, NHP1300S, NHP1320S	3/8" - 24UNF	192282-9
6333DW	-	192284-5

Angle Attachment

For drilling in close quarters, incorners, between joints and studs.

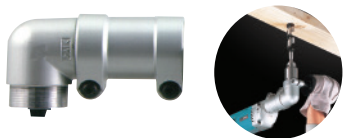

For Model	No Load Speed	Part No.
DS4011, 6013BR, 6300LR	High: 800rpm Low: 350rpm	STEX122177

A: Grip assembly B: Grip Complete

For Model	Type	Grip
DBM131	B	EE7DE33695
UT2204	B	152892-4
6013BR / 6016 / 6300-4 / DA4000LR / DS4011 / DP4700	B	152492-0 151965-0
8419B2	C	273627-1
8419B	C	273479-0
8416 / 8420V / HP2000 / HP2010N	C	273627-1
8416 / 8420V / HP2000 / HP2010N	A	123018-5
NHP1300S / NHP1320S	B	152491-2
HP2050/F, HP2051/F, HP2070/F, HP2071/F, HP1640/F, HP1641/F, HP1630 HP1631, HP1230	B	153503-4
HP2010N, HP2000	A	122428-3
DF001G	A	127552-7
HP001G	A	127551-9
DDF481	A	126412-0
DHP481	A	126413-8
UT1305	B	152892-4

DRILL BITS / CHISELS

[CONCRETE / HAMMER ACCESSORIES]





- BATTERY / CHARGERS
- FIXING FASTENING (SCREWDRIVER BITS / IMPACT SOCKETS)
- DRILLING (WOOD / METAL/ MASONRY)
- DRILLING / DEMOLITION [CONCRETE]
- CUTTING [METAL]
- MULTI TOOL ACCESSORIES
- DIAMOND [CUTTING / GRINDING]
- GRINDING ACCESSORIES
- SANDING / POLISHING ACCESSORIES
- SAWING ACCESSORIES
- ROUTERS / PLANERS ACCESSORIES
- CLEANERS ACCESSORIES
- HEAT GUN / LASERS ACCESSORIES
- BRAD NAILS/ PINS STAPLER
- GARDEN TOOLS ACCESSORIES
- HAND TOOLS / COMBINATION SETS

SDS-PLUS DRILL BITS

Adapted for SDS-PLUS Rotary Hammers

PREMIUM RANGE

Best in its class

For more productivity and accuracy

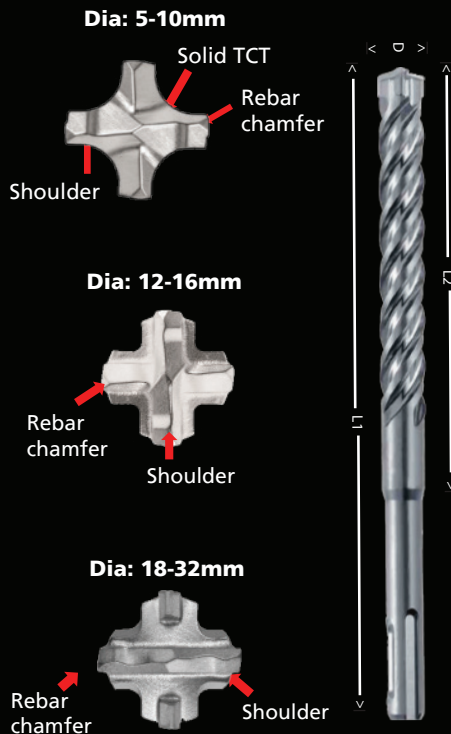

Solid Type TCT -

For maximum impact and torsion forces as well as prolonged service life

Shorter Entrance -

The drilling dust travels quickly from the drill head into the spiral flute

Rebar Chamfer -

Leads to an increased life time and optimum drilling behavior in reinforcement strikes

Shoulder -

Two elevation on the cutting edge, provide improved breaking performance in concrete and optimal reinforcement strength

Innovated Flute Geometry -

the drilling dust is removed faster, while at the same time ensuring low-vibration drilling and a high degree of fracture safety

Wearing Mark -

Wearing mark serves as an indication on the life of the drill bit and a high degree of fracture safety

BIT DIA (D) (MM)	OVERALL LENGTH (L1) (MM)	WORKING LENGTH (L2) (MM)	PER PKG	NEMESIS II PART NO (NEW)	NEMESIS PART NO
5	115	50	1	B-57897	-
5	165	100	1	B-57906	-
6	115	50	1	B-57962	-
6	165	100	1	B-57978	-
6	215	150	1	B-57984	-
6	265	200	1	B-57990	-
7	115	50	1	B-58067	B-11754
7	165	100	1	B-58073	-
8	115	50	1	B-58095	-
8	165	100	1	B-58104	-
8	215	150	1	B-58110	-
8	265	200	1	B-58126	B-11807
10	115	50	1	B-58198	-
10	165	100	1	B-58207	-
10	215	150	1	B-58213	-
10	265	200	1	B-58229	-
10	315	250	1	B-58235	-
10	455	390	1	B-58257	-
12	160	110	1	B-58322	-
12	210	160	1	B-58338	-
12	260	210	1	B-58344	-
12	310	260	1	B-58350	-
12	450	400	1	B-58366	-
14	160	110	1	B-58431	-
14	210	160	1	B-58447	-
14	260	210	1	B-58453	-
14	310	260	1	B-58469	-
14	450	400	1	B-58475	-
15	160	110	1	B-58506	B-14205
15	210	160	1	B-58512	B-14211
16	160	110	1	B-58540	-
16	210	160	1	B-58556	-
16	260	210	1	B-58562	-
16	310	260	1	B-58578	-
16	450	400	1	B-58584	-
18	250	200	1	B-58615	-
18	450	400	1	B-58621	-
20	250	200	1	B-58637	-
20	450	400	1	B-58659	-
22	250	200	1	B-58665	-
22	450	400	1	B-58687	-
24	250	200	1	B-58693	B-12108
24	450	400	1	B-58702	B-12114
25	250	200	1	B-58718	-
25	450	400	1	B-58724	-
28	250	200	1	B-58746	-
28	450	400	1	B-58752	B-12158
30	250	200	1	B-58768	B-12164
30	450	400	1	B-58774	B-12170
32	450	400	1	B-58780	-

SDS-PLUS DRILL BITS



Adapted for
SDS-PLUS Rotary Hammers



STANDARD RANGE

- 2 cutter SDS plus drill bits suitable for masonry and concrete.
- The solid carbide tip with centering point and optimized flutes offers fast drilling speeds.

BIT DIA (D) (MM)	OVERALL LENGTH (L1) (MM)	WORKING LENGTH (L2)(MM)	PER PKG	PART NO	PART NO WITH COUNTRY OF ORIGIN
4.0	110	50	1		D-00402
5.0	110	50	1		D-00418
5.0	160	100	1		D-00424
5.0	210	150	1		D-66628
5.5	110	50	1		D-00430
6.0	110	50	1		D-00446
6.0	160	100	1		D-00452
6.0	210	150	1		D-00468
6.5	260	200	1		D-66634
7.0	110	50	1		D-00496
7.0	160	100	1		D-00505
8.0	110	50	1		D-00511
8.0	160	100	1		D-00527
8.0	210	150	1		D-00533
8.0	260	200	1		D-00549
9.0	160	100	1	D-08056(A)	
9.0	210	150	1		D-00555
10	160	100	1		D-00561
10	210	150	1		D-00577
10	260	200	1		D-00583
10	310	250	1		D-00599
10	350	290	1		D-66656
11	160	100	1	D-00212(A)	-
11	160	100	1		D-00608
11	260	200	1		D-66678
12	160	100	1		D-00614
12	210	150	1		D-00620
12	260	200	1		D-00636
12	310	250	1		D-66684
12	460	400	1		D-29088
13	160	100	1		D-00642

BIT DIA (D) (MM)	OVERALL LENGTH (L1) (MM)	WORKING LENGTH (L2)(MM)	PER PKG	PART NO	PART NO WITH COUNTRY OF ORIGIN
14	160	100	1		D-00658
14	260	200	1		D-00664
14	310	250	1		D-66709
14	460	400	1		D-29094
15	160	100	1		D-00670
16	210	150	1		D-00686
16	310	250	1		D-00692
16	460	400	1		D-29103
17	210	150	1		D-00701
18	210	150	1		D-00717
18	300	250	1		D-00723
18	460	400	1	D-17566	-
19	210	150	1		D-00739
19	460	400	1	D-16293	-
20	210	150	1		D-00745
20	310	250	1		D-00751
20	460	400	1		D-16900
22	260	200	1		D-00767
22	310	250	1	D-08062(A)	-
22	460	400	1		D-16916
24	460	400	1	D-16302	
25	260	200	1		D-00773
25	310	250	1	D-08517(A)	-
25	460	400	1		D-16922
26	260	200	1		D-00789
26	460	400	1	D-15263	-
28	460	400	1	D-16318	-
30	460	400	1	D-17572	-

BATTERY / CHARGERS

FIXING FASTENING (SCREWDRIVER BITS / IMPACT SOCKETS)

DRILLING (WOOD / METAL/ MASONRY)

DRILLING / DEMOLITION [CONCRETE]

CUTTING [METAL]

MULTI TOOL ACCESSORIES

DIAMOND [CUTTING / GRINDING]

GRINDING ACCESSORIES

SANDING / POLISHING ACCESSORIES

SAWING ACCESSORIES

ROUTERS / PLANERS ACCESSORIES

CLEANERS ACCESSORIES

HEAT GUN / LASERS ACCESSORIES

BRAD NAILS/ PINS STAPLER

GARDEN TOOLS ACCESSORIES

HAND TOOLS / COMBINATION SETS

BATTERY / CHARGERS

FIXING FASTENING (SCREWDRIVER BITS / IMPACT SOCKETS)

DRILLING (WOOD / METAL / MASONRY)

DRILLING / DEMOLITION [CONCRETE]

CUTTING [METAL]

MULTI TOOL ACCESSORIES

DIAMOND [CUTTING / GRINDING]

GRINDING ACCESSORIES

SANDING / POLISHING ACCESSORIES

SAWING ACCESSORIES

ROUTERS / PLANERS ACCESSORIES

CLEANERS ACCESSORIES

HEAT GUN / LASERS ACCESSORIES

BRAD NAILS/ PINS STAPLER

GARDEN TOOLS ACCESSORIES

HAND TOOLS / COMBINATION SETS

14 pcs SDS-PLUS drill bit

(Assorted) with aluminum case.



Adapted for SDS-PLUS Rotary Hammers



Bit Dia (mm)	Overall Length (mm)	Working Length (mm)	Per Pkg	Part No
5	110	42	1	D-21325
6	110	42	1	
6	160	92	1	
7	110	42	1	
7	160	92	1	
8	110	42	1	
8	160	92	1	
10	160	92	1	
10	210	140	1	
12	160	92	1	
12	210	140	1	
14	160	92	1	
14	210	140	1	
16	210	140	1	

13 pcs SDS-PLUS drill bit / chisel set

(Assorted) with aluminum case.



Adapted for SDS-PLUS Rotary Hammers



Bit Dia (mm)	Overall Length (mm)	Working Length (mm)	Per Pkg	Part No	
5	110	42	1	D-20111	
6	110	42	1		
6	160	92	1		
7	110	42	1		
7	160	92	1		
8	110	42	1		
8	160	92	1		
10	160	92	1		
12	160	92	1		
14	160	92	1		
16	210	140	1		
Bull Point 250mm			1		
Cold Chisel 20x250mm			1		

6 pcs SDS-PLUS drill bit / chisel set

(Assorted)



Adapted for SDS-PLUS Rotary Hammers



Bit Dia (mm)	Overall Length (mm)	Working Length (mm)	Per Pkg	Part No	
5	160	100	1	D-58920	
6	160	100	1		
8	160	100	1		
Bull Point 250mm			1		
Cold Chisel 20x250mm			1		
Scaling Chisel 40x250mm			1		

5 pcs SDS-PLUS drill bit

(Assorted) with plastic case.



Adapted for SDS-PLUS Rotary Hammers



Bit Dia (mm)	Overall Length (mm)	Working Length (mm)	Per Pkg	Part No	Part No
5	110	42	1	P-29751	D-00795
6	110	42	1		
6	160	92	1		
8	110	42	1		
8	160	92	1		

SDS-MAX ZENTRO DRILL BITS

PREMIUM RANGE

Ø 12 to 15 mm : 2 cutter

Ø 16 - 50mm: 4 Cutter new carbides for better performance in reinforce concrete

Ø 32mm to 50mm: 4 Cutter and additionally reinforced carbide tip



Adapted for SDS-MAX Hammers

Power

Specially developed robust head geometry ensures that even toughest applications can be mastered.

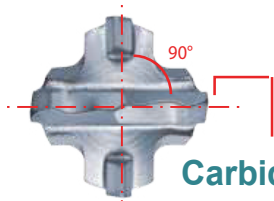

Carbide Tip

The optimal 4x90° carbide cutting edge symmetry prevents seizing up on hitting reinforcing steel.

Fast Drilling

Large, robust secondary cutters with dynamically curved cutting tips actively support the main carbide tip during fast drilling.

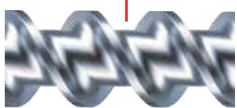

Flute

The drilling debris is transported fast in the large-volume flute geometry.

Accuracy

Centering point with 130° point angle ensures highly accurate, precise drilling and guarantees optimal drill guidance.

The individual wear marking is an indicator for evaluating the dimensional stability of the anchor holes.



Impact Energy

The reinforced-core flute achieves the optimum between volume and break resistance. Vibrations are dampened and resulting in more impact energy on the carbide tip.

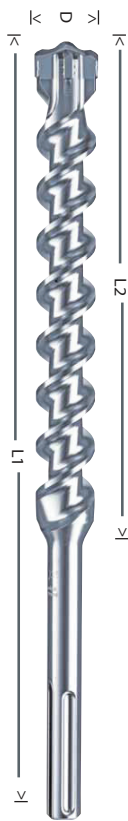

BIT DIA (MM)	OVERALL LENGTH (MM)	WORKING LENGTH (MM)	PER PKG	PART NO	PART NO
12	340	200	1	P-17033	—
12	540	400	1	P-17049	—
12	690	550	1	P-17055	—
14	340	200	1	P-17077	—
14	540	400	1	P-17083	—
15	340	200	1	P-17108	—
15	540	400	1	P-17114	—
16	340	200	1	—	P-77730
16	540	400	1	—	P-77746
18	340	200	1	—	P-77774
18	540	400	1	—	P-77780
20	320	200	1	—	P-77811
20	520	400	1	—	P-77827
20	920	800	1	—	P-77833
22	320	200	1	—	P-77855
22	520	400	1	—	P-77861
22	920	800	1	—	P-77877
24	320	200	1	—	P-77899
24	520	400	1	—	P-77908
25	320	200	1	—	P-77914
25	520	400	1	—	P-77920
25	920	800	1	—	P-77936
28	370	250	1	—	P-77964
28	570	450	1	—	P-77970
28	670	550	1	P-17310	P-77986
30	370	250	1	P-17326	P-78019
30	570	450	1	—	P-78025
32	370	250	1	P-17348	P-78031
32	570	450	1	—	P-78047
32	920	800	1	—	P-78053
35	370	250	1	—	P-78075
35	570	450	1	—	P-78081
35	670	550	1	P-17398	P-78097
38	370	250	1	P-17407	P-78134
38	570	450	1	P-17413	P-78140
40	370	250	1	P-17429	P-78156
40	570	450	1	—	P-78162
40	920	800	1	P-17441	P-78178
40	1320	1200	1	—	P-78184
45	570	450	1	—	P-78190
50	570	450	1	—	P-78215

BATTERY / CHARGERS
FIXING FASTENING (SCREWDRIVER BITS / IMPACT SOCKETS)
DRILLING (WOOD / METAL/ MASONRY)
DRILLING / DEMOLITION [CONCRETE]
CUTTING [METAL]
MULTI TOOL ACCESSORIES
DIAMOND [CUTTING / GRINDING]
GRINDING ACCESSORIES
SANDING / POLISHING ACCESSORIES
SAWING ACCESSORIES
ROUTERS / PLANERS ACCESSORIES
CLEANERS ACCESSORIES
HEAT GUN / LASERS ACCESSORIES
BRAD NAILS/ PINS STAPLER
GARDEN TOOLS ACCESSORIES
HAND TOOLS / COMBINATION SETS

- BATTERY / CHARGERS
- FIXING FASTENING (SCREWDRIVER BITS / IMPACT SOCKETS)
- DRILLING (WOOD / METAL/ MASONRY)
- DRILLING / DEMOLITION [CONCRETE]
- CUTTING [METAL]
- MULTI TOOL ACCESSORIES
- DIAMOND [CUTTING / GRINDING]
- GRINDING ACCESSORIES
- SANDING / POLISHING ACCESSORIES
- SAWING ACCESSORIES
- ROUTERS / PLANERS ACCESSORIES
- CLEANERS ACCESSORIES
- HEAT GUN / LASERS ACCESSORIES
- BRAD NAILS/ PINS STAPLER
- GARDEN TOOLS ACCESSORIES
- HAND TOOLS / COMBINATION SETS

SDS-MAX rotary hammer drill bits

STANDARD RANGE



Adapted for SDS-MAX Hammers

- 2 cutter T.C.T Drill bits
- Solid carbide centering tip
- Optimized flutes for fast drilling
- Long Life



BIT DIA (D) (MM)	OVERALL LENGTH (L1) (MM)	WORKING LENGTH (L2)(MM)	PER PKG	PART NO	NEW PART NO (WITH COUNTRY OF ORIGIN)
12	340	200	1	-	D-34506
12	540	400	1	D-33881	D-34512
14	340	200	1	-	D-34528
14	540	400	1	-	D-34534
15	340	200	1	-	D-34540
15	540	400	1	D-33928	D-34556
16	340	200	1	-	D-34562
16	540	400	1	-	D-34578
18	340	200	1	-	D-34584
18	540	400	1	-	D-34590
20	340	200	1	-	D-34609
20	540	400	1	-	D-34615
22	340	200	1	-	D-34621
22	540	400	1	-	D-34637
24	340	200	1	-	D-34643
24	540	400	1	-	D-34659
25	340	200	1	-	D-34665
25	540	400	1	-	D-34671
28	370	250	1	-	D-34687
28	570	450	1	-	D-34693
30	370	250	1	-	D-34702
30	570	450	1	-	D-34718
32	370	250	1	-	D-34724
32	570	450	1	-	D-34730
35	370	250	1	-	D-34746
35	570	450	1	-	D-34752
38	370	250	1	-	D-34768
38	570	450	1	-	D-34774
40	370	250	1	-	D-34780
40	570	450	1	-	D-34796

Hexagonal shank



Premium range

Tungsten carbide-tipped bit



For Model	Bit Dia (D) (mm)	Overall Length (L1) (mm)	Working Length (L2) (mm)	Per Pkg	Part No
HR3850, HR4030C	16	550	-	1	P-02799
	18	280	-	1	P-02808
	18	550	-	1	P-02814
	18	550	-	1	P-02814
	19	280	-	1	P-02820
	19	550	-	1	P-02836
	20	280	-	1	P-02842
	20	550	-	1	P-02858
	20	555	-	1	B-00153
	22	550	-	1	P-02870
	22	905	-	1	791202-6
	22	905	-	1	P-02892
	25	280	-	1	P-02892
	25.5	905	-	1	791203-4
	28	280	-	1	P-02923
	28	550	-	1	P-02939
	28	905	-	1	P-02945
	30	280	-	1	P-02951
	30	550	-	1	P-02967
	32	550	-	1	P-02989
35	280	-	1	P-02995	
35	905	-	1	P-03012	
38	280	-	1	P-03028	
38	550	-	1	P-03034	
38	555	-	1	B-00228	

Standard range

Tungsten carbide-tipped bit

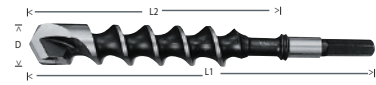

For Model	Bit Dia (D) (mm)	Overall Length (L1) (mm)	Working Length (L2) (mm)	Per Pkg	Part No
HR3520, HR3530, HR3540C, HR3850, HR4030C	16	280	155	1	D-20127
	16	505	365	1	D-20133
	18	280	155	1	D-20149
	18	505	365	1	D-20155
	19	280	155	1	D-20161
	19	505	365	1	D-20177
	20	280	155	1	D-20183
	20	505	365	1	D-20199
	22	280	155	1	D-20208
	22	505	365	1	D-20214
	25.5	280	155	1	D-20220
	25.5	505	365	1	D-20236
	28	280	155	1	D-20242
	28	505	365	1	D-20258
	32	280	140	1	D-20264
	32	505	360	1	D-20270
	35	280	140	1	D-20286
	35	505	360	1	D-20292

Taper Shank



For Model	Bit Dia(mm)	Overall length (mm)		Part No.
All Rotary Hammers Except SDS-PLUS SDS-MAX	6.5	90	1	791152-5
	7.5	90	1	791153-3
	8	100	1	791154-1
	8.5	100	1	791155-9
	9.5	120	1	791156-7
	10	120	1	A-21113
	10.5	120	1	791054-5
	10.5	160	1	791215-7
	11	120	1	791017-1
	11.5	120	1	791055-3
	12	120	1	791018-9
	12.5	120	1	791056-1
	13.3	120	1	791026-0
	18	120	1	791016-3
	12.7	120	1	791216-5
	13	160	1	791218-1
	16	160	1	791166-4
	18	220	1	791167-2
	19	220	1	791168-0
	20	220	1	791169-8
	21.5	110	1	791165-6
	21.5	135 (morse taper # 2 model HR3850)	1	791019-7
22	220	1	791170-3	

Taper Shank Adapter



Allows the use of taper shank bits

Shank	Bit Type	Part No.
For model: HR2510, HR2220		
	Morse taper #1	798131-4
	A-taper	798176-2
For model: HR3520, HR3850		
	Morse taper #1	798001-7
	Morse taper #1	A-47597
	Morse taper #2	798002-5
	A-taper	798004-1
	B-taper	798005-9
	For model: HR3520B, HR3850B	
	Morse taper #1	798328-5
	A-taper	798135-6
For model: 8050		
For model 8050	B-taper	798210-8
Cotter (Drift Key)		
To remove bit from taper shank adapter.		
Type	Part No.	
Cotter	765010-1	

BATTERY / CHARGERS

FIXING FASTENING (SCREWDRIVER BITS / IMPACT SOCKETS)

DRILLING (WOOD / METAL / MASONRY)

DRILLING / DEMOLITION [CONCRETE]

CUTTING [METAL]

MULTI TOOL ACCESSORIES

DIAMOND [CUTTING / GRINDING]

GRINDING ACCESSORIES

SANDING / POLISHING ACCESSORIES

SAWING ACCESSORIES

ROUTERS / PLANERS ACCESSORIES

CLEANERS ACCESSORIES

HEAT GUN / LASERS ACCESSORIES

BRAD NAILS / PINS STAPLER

GARDEN TOOLS ACCESSORIES

HAND TOOLS / COMBINATION SETS

- BATTERY / CHARGERS
- FIXING FASTENING (SCREWDRIVER BITS / IMPACT SOCKETS)
- DRILLING (WOOD / METAL/ MASONRY)
- DRILLING / DEMOLITION [CONCRETE]
- CUTTING [METAL]
- MULTI TOOL ACCESSORIES
- DIAMOND [CUTTING / GRINDING]
- GRINDING ACCESSORIES
- SANDING / POLISHING ACCESSORIES
- SAWING ACCESSORIES
- ROUTERS / PLANERS ACCESSORIES
- CLEANERS ACCESSORIES
- HEAT GUN / LASERS ACCESSORIES
- BRAD NAILS/ PINS STAPLER
- GARDEN TOOLS ACCESSORIES
- HAND TOOLS / COMBINATION SETS

SDS-MAX Mining bits



Adapted for SDS-MAX Hammers

- Can drill into rocks and natural stones which are extremely hard.
- Suitable for drilling holes for dynamite bar and tunnels in mining fields.
- Longer life & high speed compare

BIT DIA (D) (MM)	OVERALL LENGTH (L1) (MM)	WORKING LENGTH (L2)(MM)	PER PKG	PART NO
26	670	550	1	B-39431
30	720	600	1	B-39447
32	570	450	1	B-39453
32	920	800	1	B-39469

Durable and Longer life



+37% carbide

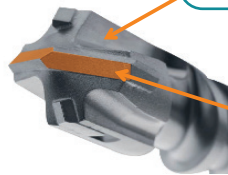

High volume flute entries: Drilling debris leads to less friction in hole

Optimized for regrinding

Recommended procedure to prevent breakage - Mining bits

To prevent from bit breakage, we recommended to perform the drilling in 3 stages as below

Stage 1: Drilling with a drill bit of 340mm long at initial stage



Stage 2: Drilling with a drill bit of 570mm long in between initial and final stage



Stage 3: Drilling with a drill bit of 920mm long at final stage



These stages will help to avoid bending of the drill bit when the longer one is used and will be convenient to use as well. Use of either a blower or vacuum cleaners is recommended to remove the debris while drilling.

Our normal P-series SDS Max drill bits can be used for smaller lengths.









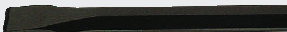

Chisels

The right chisel for every chiseling job

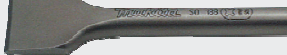
Advantages:

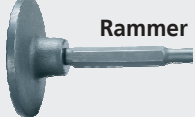
- Use of high-grade tempered steel
- Special processing and hardening process for optimal tool-life
- Minimized wear and tear
- Increased surface hardness and endurance range

Application	FOR SDS-PLUS HAMMERS	FOR SDS-MAX HAMMERS	17MM HEX	19MM HEX	21MM HEX	28.6MM HEX	30MM HEX	MAKITA SMALL
Self sharpening bull point  <p>Demolition and adjustment work in masonry and concrete. Chipping and breaking in masonry and concrete. Starts holes in concrete. No time consuming resharpening is needed.</p>		●				●	●	
Bull point  <p>Demolition and adjustment work in masonry and concrete. Chipping and breaking in masonry and concrete. Starts holes in concrete</p>	●	●	●	●	●	●	●	●
Cold chisel  <p>Adjustment work in masonry and concrete. Chipping, breaking, edging and channeling in masonry and concrete.</p>	●	●	●	●	●	●	●	
Grooving chisel  <p>Cutting channels in concrete.</p>	●		●		●			
Scaling chisel  <p>Removing concrete residues.</p>	●	●	●	●	●	●	●	●
Clay spade  <p>Digging in clay, hard gravel, hard packed gravel, soil and dirt.</p>	●	●	●	●	●	●	●	
Rammer  <p>Tamping asphalt and compacting gravel, soil and dirt.</p>		●	●	●	●	●		
Bushing tool  <p>Roughing concrete and asphalt up.</p>	●	●	●		●			
Scraper  <p>Scraping floor tiles, linoleum floor and clean-up.</p>	●							●

BATTERY / CHARGERS

FIXING FASTENING (SCREWDRIVER BITS / IMPACT SOCKETS)

DRILLING (WOOD / METAL/ MASONRY)

DRILLING / DEMOLITION [CONCRETE]

CUTTING [METAL]

MULTI TOOL ACCESSORIES

DIAMOND [CUTTING / GRINDING]

GRINDING ACCESSORIES

SANDING / POLISHING ACCESSORIES

SAWING ACCESSORIES

ROUTERS / PLANERS ACCESSORIES

CLEANERS ACCESSORIES

HEAT GUN / LASERS ACCESSORIES

BRAD NAILS/ PINS STAPLER

GARDEN TOOLS ACCESSORIES

HAND TOOLS / COMBINATION SETS

- BATTERY / CHARGERS
- FIXING FASTENING (SCREWDRIVER BITS / IMPACT SOCKETS)
- DRILLING (WOOD / METAL/ MASONRY)
- DRILLING / DEMOLITION [CONCRETE]
- CUTTING [METAL]
- MULTI TOOL ACCESSORIES
- DIAMOND [CUTTING / GRINDING]
- GRINDING ACCESSORIES
- SANDING / POLISHING ACCESSORIES
- SAWING ACCESSORIES
- ROUTERS / PLANERS ACCESSORIES
- CLEANERS ACCESSORIES
- HEAT GUN / LASERS ACCESSORIES
- BRAD NAILS/ PINS STAPLER
- GARDEN TOOLS ACCESSORIES
- HAND TOOLS / COMBINATION SETS

Premium chisels

- No need to re-sharpen It is possible to demolish concrete for a longer time
- Suitable for indoor decorators, constructors and masonry worker who use SDS-PLUS and SDS-MAX hammers





Special shape of the tip gives superior performance

Long Life





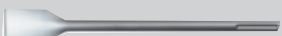

New technology ensures our steels remain sharp and efficient through out their life time. With a higher material removal rate and no repeated re-sharpening these new sheets reduces downtime and are significantly more cost effective



Shank type	Chisels	length (mm)	Width (mm)	Part no
 FOR SDS-PLUS HAMMERS	Premium Bull point 	250	-	B-64238
	Premium Cold chisel 	250	20	B-64244
	Premium Scaling chisel 	250	40	B-64250
 FOR SDS-MAX HAMMERS	Premium Bull point 	400	-	B-64266
	Premium Cold chisel 	400	25	B-64272
	Premium Scaling chisel 	380	50	B-64288







Bull Point

- For demolishing concrete

Suitable For	Length (mm)	Part No.	New Part No (With country of origin)	Part No.
 Adapted for all SDS-MAX hammers	280			A-80787
	300		D-34425	-
	400		D-34431	A-80793
	600		D-34447	P-16259
	600		-	A-87476
 Adapted for all SDS-PLUS hammers	160	D-08034	D-20731	-
	250		D-07864	-
	400	D-19015	-	-
 HR3520B, HR3850B, HR5000	300		D-29234	-
	450		D-29240	-
 17 mm HR3520, HR3850, HR4030C, HM0810, HM0810T, HM1130	210	D-16374	D-26565	-
	280	D-08682	D-08676	-
	450		-	A-80547
 21 mm HM1201	320		-	A-82747
	450	-	-	A-80553
	600	D-30994	-	-
 30 mm HM1302, HM1303, HM1304, HM1305, HM1306, HM1307C, HM1317C	410		D-15279	A-80466
 28.6 mm HM1800, HM1801, HM1810, HM1812, HM1802	410		D-20747	
Makita small shank HK1800, HK1810, DHK180	220	-	-	B-06921

Cold Chisel

- For chipping, edging, channeling and breaking concrete chunks

Suitable For	Length (mm)	Part No.	New Part No (With country of origin)	Part No.
 Adapted for all SDS-MAX hammers	24 x 600			P-16287
	25 x 280			A-80802
	25 x 300		D-34453	
	25 x 400		D-34469	A-80818
	25 x 600		D-34475	
 Adapted for all SDS-PLUS hammers	20 x 250		D-07870	
	20 x 400	D-19021		
 HR3520B, HR3850B, HR5000	26 x 300		D-29250	798139-8
	26 x 450		D-29262	
 17 mm HR3520, HR3850, HR4030C, HM0810, HM0810T, HM1130	17 x 280		D-08698	A-80569
	17 x 450			A-80575
 21 mm HM1201	26 x 450			A-80581
 30 mm HM1302, HM1303, HM1304, HM1305, HM1306, HM1307C, HM1317C	36 x 410		D-15291	
 28.6 mm HM1800, HM1801, HM1810, HM1812, HM1802	28 x 410	D-17647	D-20753	798383-7

BATTERY / CHARGERS

FIXING FASTENING (SCREWDRIVER BITS / IMPACT SOCKETS)

DRILLING (WOOD / METAL / MASONRY)

DRILLING / DEMOLITION [CONCRETE]

CUTTING [METAL]

MULTI TOOL ACCESSORIES

DIAMOND [CUTTING / GRINDING]

GRINDING ACCESSORIES

SANDING / POLISHING ACCESSORIES

SAWING ACCESSORIES

ROUTERS / PLANERS ACCESSORIES

CLEANERS ACCESSORIES

HEAT GUN / LASERS ACCESSORIES

BRAD NAILS/ PINS STAPLER







GARDEN TOOLS ACCESSORIES

HAND TOOLS / COMBINATION SETS

Scaling Chisel

- Wide chisels for chipping away scale of concrete spatter





Suitable For	Length (mm)	Part No.	New Part No (With country of origin)	Part No.
 Adapted for all SDS-MAX hammers	50 x 300		D-34481	A-80830
	50 x 400		D-34497	A-80824
	80 x 300		D-07886	
 Adapted for all SDS-PLUS hammers	40 x 250			A-87052
	50 x 215	D-25616		
	80 x 250		D-61020	
	80 x 150		D-61042	
 HR3520B, HR3850B, HR5000	50 x 215			A-86387
	50 x 300		D-29278	
 17 mm HR3520, HR3850, HR4030C, HM0810, HM0810T, HM1130	50 x 280	D-20694	D-26618	A-80606
 21 mm HM1201	70 x 320	D-20672		
 30 mm HM1302, HM1303, HM1304, HM1305, HM1306, HM1307C, HM1317C	75 x 310	D-23868		
 28.6 mm HM1800, HM1801, HM1810, HM1812, HM1802	75 x 520	D-20725	D-26646	
MAKITA SMALL SHANK HK1800, HK1810, DHK180	50 x 150			B-07347
	20 x 220			B-07004
	50 x 220			B-07010

Grooving chisels

- For grooving, channeling or removal of heavy scale



Suitable For	Length (mm)	Part No.
 Adapted for all SDS-PLUS hammers	8 x 170	A-30075
	12 x 170	A-86371
 HR3520B, HR3850B, HR5000	22 x 300	798142-9
	26 x 300	798143-7
 17 mm HR3520, HR3850, HR4030C, HM0810, HM0810T, HM1130	26 x 280	A-48561
 21 mm HM1201	22 x 370	798275-0
MAKITA SMALL SHANK HK1800, HK1810, DHK180	12 x 170	A-21559

Clay Spade

• For digging in clay, scale etc.









Suitable For	Length (mm)	Part No.
 Adapted for all SDS-PLUS hammers	105 x 400	A-17653
 HR3520B, HR3850B, HR5000	105 x 400	798148-7
		798035-0
 21 mm HM1201	120 x 450	A-47391
 30 mm HM1302, HM1303, HM1304, HM1305, HM1306, HM1307C, HM1317C	120 x 500	B-10300
 28.6 mm HM1800, HM1801, HM1810, HM1812, HM1802	140 x 546	A-44644
		798384-5

Rammer

• For tamping operations



Suitable For	Length (mm)	Part No.
 Adapted for all SDS-MAX hammers	140	A-19875
 HR3520B, HR3850B, HR5000	140	798149-5
		798390-0
 17 mm HR3520, HR3850, HR4030C, HM0810, HM0810T, HM1130	140	798390-0
 21 mm HM1201	140	798224-7 / A-21434
 30 mm HM1302, HM1303, HM1304, HM1305, HM1306, HM1307C, HM1317C	200	A-31485
 28.6 mm HM1800, HM1801, HM1810, HM1812, HM1802	200	798385-3

BATTERY / CHARGERS

FIXING FASTENING (SCREWDRIVER BITS / IMPACT SOCKETS)

DRILLING (WOOD / METAL / MASONRY)

DRILLING / DEMOLITION [CONCRETE]

CUTTING [METAL]

MULTI TOOL ACCESSORIES

DIAMOND [CUTTING / GRINDING]

GRINDING ACCESSORIES

SANDING / POLISHING ACCESSORIES

SAWING ACCESSORIES

ROUTERS / PLANERS ACCESSORIES

CLEANERS ACCESSORIES

HEAT GUN / LASERS ACCESSORIES

BRAD NAILS/ PINS STAPLER

GARDEN TOOLS ACCESSORIES

HAND TOOLS / COMBINATION SETS

BATTERY / CHARGERS

FIXING FASTENING (SCREWDRIVER BITS / IMPACT SOCKETS)

DRILLING (WOOD / METAL/ MASONRY)

DRILLING / DEMOLITION [CONCRETE]

CUTTING [METAL]

MULTI TOOL ACCESSORIES

DIAMOND [CUTTING / GRINDING]

GRINDING ACCESSORIES

SANDING / POLISHING ACCESSORIES

SAWING ACCESSORIES

ROUTERS / PLANERS ACCESSORIES

CLEANERS ACCESSORIES

HEAT GUN / LASERS ACCESSORIES

BRAD NAILS/ PINS STAPLER





GARDEN TOOLS ACCESSORIES

HAND TOOLS / COMBINATION SETS

Bushing Tool

- For concrete surface removal
- Type A: Use with shank (A-19897)



Suitable For	Length (mm)	Type	Part No.
 Adapted for all SDS-MAX hammers	67 x 67	A	A-19881
 HR3520B, HR3850B, HR5000	67 x 67	-	798144-5
 17 mm HR3520, HR3850, HR4030C, HM0810, HM0810T, HM1130	60 x 60	-	A-21484
 21 mm HM1201	60 x 60	-	A-21490

MULTI TOOL ACCESSORIES

DIAMOND [CUTTING / GRINDING]

Scraper Assembly

- For removing linoleum tile and other flooring

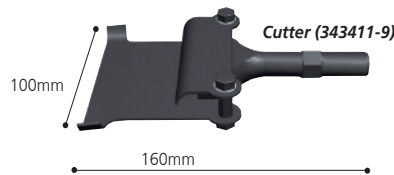

Suitable For	Length (mm)	Part No.
 Adapted for all SDS-PLUS hammers	100	A-30106

GRINDING ACCESSORIES

SANDING / POLISHING ACCESSORIES

SAWING ACCESSORIES

ROUTERS / PLANERS ACCESSORIES

SDS-PLUS Chisel Assortment (3pcs/set)

With aluminum case.

-  Adapted for all SDS-PLUS hammers



Suitable For	Length (mm)	Part No.	New Part No (With country of origin)
Bull point	250	D-05181	D-08763
Cold chisel	20 x 250		
Scaling chisel	40 x 250		

HEAT GUN / LASERS ACCESSORIES

BRAD NAILS/ PINS STAPLER

GARDEN TOOLS ACCESSORIES

Chisel adapter



Suitable For	Part No.
HR2470, HR2470T, HR3000C, HR3200C, HR3210C	122547-5

Core Bit

For use in Concrete, Masonry and Natural stone

Makita offers a comprehensive range of tools and accessories for heavy rotary hammer drills.

Ratio Quick Core Bit

Ratio Quick core bit, together with pilot bits, flute bodies, shank extensions and adapters make up the Ratio System a tool system which allows the individual components to be used in various combinations.

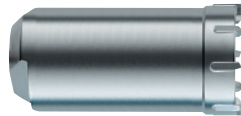

Core Bit Ø (mm)	Core bit Length	Max drilling Depth (mm)	Part No.
40	105	150	P-16813(H)
65	105	150	P-16835(H)
68	105	150	P-16841(H)

Ratio SDS-MAX Adapter (Versio System)



SDS-MAX	195	P-03888(H)
---------	-----	-------------------

Please Note: Ratio Core Bits and accessories are not interchangeable with any other core bit system

TCT Hollow Core Bit System



For Core Bit Dia. (mm)	Max. drilling depth (mm)	Hollow core Cutter	Centering Bit 1:20	Drift Key
		Part No.	Part No.	Part No.

For Model: HR4000C, HR4001C, HR4002, HR4011C, HR4500C, HR4501C, HR4511C, HR5001C, HR5201C

65	100	P-03791	P-03838 11 x 120	P-03763 140mm
----	-----	----------------	----------------------------	-------------------------

Hollow Core Bit Adapter



Adapted for SDS-PLUS hammers



Adapted for SDS-MAX hammers

	Overall Length (mm)	Part No.
--	---------------------	----------

Adapted for SDS-MAX hammers

	180	P-16994
	450	P-17005

For Model: HR3520B, HR3850B, HR4040C, HR5000

	216	P-03707
	436	P-03713

For Model: HR3520, HR3530, HR3850, HR4030

	185	P-03729
	450	P-03735

Please Note: TCT Hollow Core Bits and accessories are not interchangeable with any other core bit system

BATTERY / CHARGERS

FIXING FASTENING (SCREWDRIVER BITS / IMPACT SOCKETS)

DRILLING (WOOD / METAL / MASONRY)

DRILLING / DEMOLITION [CONCRETE]

CUTTING [METAL]

MULTI TOOL ACCESSORIES

DIAMOND [CUTTING / GRINDING]

GRINDING ACCESSORIES

SANDING / POLISHING ACCESSORIES

SAWING ACCESSORIES

ROUTERS / PLANERS ACCESSORIES

CLEANERS ACCESSORIES

HEAT GUN / LASERS ACCESSORIES

BRAD NAILS/ PINS STAPLER

GARDEN TOOLS ACCESSORIES

HAND TOOLS / COMBINATION SETS

- BATTERY / CHARGERS
- FIXING FASTENING (SCREWDRIVER BITS / IMPACT SOCKETS)
- DRILLING (WOOD / METAL/ MASONRY)
- DRILLING / DEMOLITION [CONCRETE]
- CUTTING [METAL]
- MULTI TOOL ACCESSORIES
- DIAMOND [CUTTING / GRINDING]
- GRINDING ACCESSORIES
- SANDING / POLISHING ACCESSORIES
- SAWING ACCESSORIES
- ROUTERS / PLANERS ACCESSORIES
- CLEANERS ACCESSORIES
- HEAT GUN / LASERS ACCESSORIES
- BRAD NAILS/ PINS STAPLER
- GARDEN TOOLS ACCESSORIES
- HAND TOOLS / COMBINATION SETS

TCT Core Bit

Please Note: TCT Core Bits and accessories are not interchangeable with any other core bit system



Outer dia (mm)	Depth (mm)	Max. drilling depth (mm)	Part No.
----------------	------------	--------------------------	----------

For Model: HR2440, HR2450, HR2460, HR2470/T, HR2810, HR3000C, HR3200C, HR3210C

* These sizes are not advisable for HR2440 / HR2450

*66	108	180	A-86620
*79	108	180	A-86636

For Model: HR3520, HR3850, HR4000C, HR4002, HR4030C, HR4500C, HR4501C, HR4511C, HR5000C, HR5001C, HR5201C

40	150	200	798045-7
----	-----	-----	-----------------

For Model: HR3520, HR3520B, HR3850, HR3850B, HR4000C, HR4002, HR4030C, HR4500C, HR4501C, HR4511C, HR5000, HR5001C, HR5201C

40	150	315	798151-8
45	150	315	798046-5

The below accessories for TCT Core bits which are not interchangeable with any other core bit system

Core Bit Adapter

(with center bit, O ring & rod)



Shank	For Core bit dia (mm)	Max. drilling depth (mm)	Part No.
-------	-----------------------	--------------------------	----------

For Model: HR3520, HR3850, HR4030C

	25-40	200	798006-7
---	-------	-----	-----------------

For Model: HR4000C, HR4002, HR4500C, HR4501C, HR4511C, HR5000, HR5001C

	25-40	200	A-19358
---	-------	-----	----------------

For Model: HR3520B, HR3850B

	40-118	315	798138-0
---	--------	-----	-----------------

For Model: 8050

	40-118	315	798007-5
--	--------	-----	-----------------

• Rod

[used to remove core bits]



For Model: HR2440 / F, HR2450 / F, HR2460, HR2470, HR2800, HR2810, HR3000C, HR3520, HR3520B, HR3200C, HR3210C, HR3850/B, HR4000C, HR4002, HR4501C, HR5000, HR5201C

For Core bit dia (mm)	Part No.
25-40	256806-6

• Center Bit

[for centering core bit.]



For Core bit dia (mm)	Part No.
-----------------------	----------

For Model: HR2440/F, HR2450/F, HR2460, HR2470, HR2800, HR2810, HR3000C, HR3210C

35-79	752031-2
-------	-----------------

For Model: HR3520, HR3520B, HR3850, HR3850B, HR4000C, HR4002, HR4501C, HR5000, HR5001C, HR5201C



25-40	752045-1
-------	-----------------

40-118	752027-3
--------	-----------------

Drill Chuck Adapter Assembly (For the slide chuck)

	For Models	Part No.	New Part No (With country of origin)
With screw M6 x 22 	HR2440/F, HR2450/F, HR2010, HR2400/10, HR2430, HR2800/10, HR3000C, HR3200C/10C	-	D-14087
For the swivel chuck (with screw M6 x 22) 	HR2010, HR2400, HR2410	122331-8	-
With screw M6 x 22 	HR2510	321637-360	-

Dual Slot Adapter

	Shank	Part No.
SDS-PLUS  SDS-MAX Shank	For use of SDS-PLUS drill bits with SDS-MAX hammers Adapter SDS-MAX to SDS-PLUS	P-17027
SDS-PLUS  13mm Hex Shank	For use of SDS-PLUS drill bits with 13mm Hex shank hammers Adapter 13mm Hex shank to SDS-PLUS	P-04195

Ground Rod Adapter

- For driving electrical grounding tools

	Shank	Part No.
	 17 mm HM0810/T, HM1130, HR3520, HR3850	798393-4
	 Splined Shank HR3520B, HR3850B	798132-2

Quick Change Drill Chuck

	For Models	Part No.
Quick change drill chuck set 	HR2450T/FT, HR2470T / HR2610T / HR2611FT / HR2630T / HR2630FT / DHR242	194079-2
	DHR281, DHR283, HR002G	199139-5
Quick Change drill Chuck Tool Holder Set 	HR2450T/FT, HR2470T / HR2610T / HR2611FT / HR2630T / HR2630FT	194080-7
	DHR281, DHR283, HR002G	199138-7

Drill Chuck Assembly

For SDS-Plus Hammers

		
For Models	Type	Part No.
For SDS-Plus Hammers	1/2" Keyed Chuck	122574-2

Dust Extraction System set

For SDS-Plus Hammers



For Models	Type	Part No.
HR002G	DX14	191E58-1
HR003G	DX12	191E52-3
DHR280	DX08	199579-7
DHR281, DHR283	DX09	199583-6
DHR242	DX01	195897-1

BATTERY / CHARGERS

FIXING FASTENING (SCREWDRIVER BITS / IMPACT SOCKETS)

DRILLING (WOOD / METAL / MASONRY)

DRILLING / DEMOLITION [CONCRETE]

CUTTING [METAL]

MULTI TOOL ACCESSORIES

DIAMOND [CUTTING / GRINDING]

GRINDING ACCESSORIES

SANDING / POLISHING ACCESSORIES

SAWING ACCESSORIES

ROUTERS / PLANERS ACCESSORIES

CLEANERS ACCESSORIES

HEAT GUN / LASERS ACCESSORIES

BRAD NAILS/ PINS STAPLER

GARDEN TOOLS ACCESSORIES

HAND TOOLS / COMBINATION SETS

Dust case & Filter



For Model	Type	Part No.
HR2661	Dust case + Filter	198982-9
HR2661	Filter	196164-7
DX05 (DHR182)	Dust case + Filter	199595-9
DX05 (DHR182)	Filter	199596-7
DX08, DX09, DX12, DX14	Dust case + Filter	199555-1
DX01, DX08, DX09, DX12, DX14	Filter	199557-7

Dust Cup Attachment

Suited for interior or overhead drilling where dust exposure must be controlled.



For some models grip base set is required to attach the dust cup set with the hammer

For Model	Grip base set Part no	Dust cup Set Part no
HR1841F, DHR182, DHR171, HR166D	194581-5	198362-9
DHR202, DHR263	194582-3	
HR2800, HR2810	-	195179-1
HR002G, DHR281, DHR283, HR2610T, HR2611FT, HR2630T, HR2631FT	-	
HR003G, DHR242, DHR280, HR2600, HR2630, HR2631F, HR2661	-	195173-3

Dust bag Assembly



For Model	Type	Part No.
HR2430	Standard	122614-6
HR2432	Standard	122708-7

Blow Out Bulb

To be used after drilling to clean out the hole



Part No.
765009-6

Dust Cap



Bit diameter (mm)	Part No.
6 - 14.5	421342-3
12 - 16	421664-1

Grip



For Model	Side Handle Assembly	Grip assembly	Grip 36 Complete
DHR280, 282, HR002G, HR003G, HR3011FC		126882-3	
HR2010	-	-	153503-4
HR2020 / HR2432	-	135302-6	153503-4
HR2600, 10/10T, 11F/FT, HR2630/T, HR2631F/1FT	-	122878-2	154935-8
BHR2005J	-	-	152624-9
DHR202 / HR1830 / HR2475 / HR2800 / HR2810 / DHR182	-	-	158057-6
HR3000C	-	134889-5	152554-4
HR4000C	-	134803-1	158131-0
HR3530 / HR4002 / HR4030C / HM0870C / HM0871C / HM0860C	-	-	158131-0
HR3200C, HR3210C	-	135197-7	
HR3530	-	321248-4	158131-0
HR3540C / HR3541FC / HR4001C / HR4011C / HR4501C / HR4511C	134890-0	135209-6	
HR4500C	134915-0	134916-8	273472-4
HR5201C / HR5211C	135269-8	-	
HR5202C, HR5212C		135629-4	273472-4
HR5001C	134945-1	-	
HR3520 / HR3850	-	-	273472-4
HR5000	134887-9	-	273472-4
HM0810T	-	-	273457-0
HM1101C / HM1111C	134890-0	-	-
HM1201	-	-	273467-7
HM1203C / HM1213C	135269-8	-	-
HM1214C / HR5202C / HR5212C	135283-4	-	-

Hammer Trolley

- Supports the weight in transit
- Features: Trolley for 30kg Hammer

Type A



Type B



For model	Type	Part No.
For HM1801 / HM1810T	A	791000
For HM1802, HM1812, HM1801 / HM1810T	B	D-54972

Hammer Service Kits

Essential for effective maintenance of the hammers
Consists of Carbon brush, O-rings and grease
Required whenever carbon brushes are replaced



For Breakers & Demolition Hammers

For Model	Part No.
HK0500	193397-5
HK1810	193394-1
HK1820	195194-5
HM0810T	193242-4
HM0860C	195204-8
HM0871C, HM0870C	195113-1
HM1101C, HM1111C	195260-8
HM1130	193405-2
HM1201	193244-0
HM1202C, HM1202	193391-7
HM1203C, HM1213C, HM1214C	195114-9
HM1303	193393-3
HM1304	195201-4
HM1305	183952-1
	195203-0
HM1306	195212-9
HM1307C, HM1317C	195103-4
HM1801 / HM1810	195205-6
HM1812, HM1802	197127-6

Oil Supply and Grease Vessel

For all oil lubricating machines 

Contents	Type	Part No.
Oil 100 ml	—	181118-7

For all grease lubricating machines 

Grease 30 g	R No. 00	181490-7
-------------	----------	----------

For use on the shank of the bit 

Contents	Type	Part No.
Grease 100 ml	—	194683-7

For 18 - 24mm Hammers 

Grease 100 g	FA No. 2	188088-1
--------------	----------	----------

For Rotary Hammers

A: Use with Slide-Chuck System

B: Use with Swivel-Chuck System

For Model	Type	Part No.
DHR171		198564-7
DHR182		199544-6
DHR202		195193-7
HR003G, DHR280		199233-3
HR002G, DHR242, DHR281, DHR283		195833-7
DHR263		195189-8
DHR400		197298-9
HR1830 (LOW VOLTAGE)		188388-9
HR1830		195198-7
HR2010	A	193395-9
HR2010	B	193396-7
HR2020, HR2432, HR2440, HR2450/F/T		195196-1
HR2400 (Red Chuck)	A	193386-0
HR2400 (Black Chuck)	B	193387-8
HR2410, HR2420	B	193389-4
HR2410, HR2420, HR2430, HR2431	A	193388-6
HR2460, HR2470, HR2470T		195263-2
HR2475		195109-2
HR2510		193404-4
HR2600, HR2610		195105-0
HR2611F		195107-6
HR2630		196968-7
HR2631FT, HR2611FT		195108-4
HR2631F		196967-9
HR2630T, HR2610T		195106-8
HR2800, HR2810		195206-4
HR3000C		193390-9
HR3200C, HR3210C		195199-5
HR3520		193280-6
HR3530		195211-1
HR3540, HR3541FC		195192-9
HR3850, HR3850B		193281-4
HR4000C		193283-0
HR4001C, HR4011C, HR4002		195195-3
HR4030C		195207-2
HR4003C, HR4013C		196532-4
HR4500C		193407-8
HR4501C, HR4511C		195210-3
HR5000		193284-8
HR5001C		193392-5
HR5201C, HR5211C		195191-1
HR5212C, HR5202C		196865-7

BATTERY / CHARGERS

FIXING FASTENING (SCREWDRIVER BITS / IMPACT SOCKETS)

DRILLING (WOOD / METAL / MASONRY)

DRILLING / DEMOLITION (CONCRETE)

CUTTING (METAL)

MULTI TOOL ACCESSORIES

DIAMOND (CUTTING / GRINDING)

GRINDING ACCESSORIES

SANDING / POLISHING ACCESSORIES

SAWING ACCESSORIES

ROUTERS / PLANERS ACCESSORIES

CLEANERS ACCESSORIES

HEAT GUN / LASERS ACCESSORIES

BRAD NAILS / PINS STAPLER

GARDEN TOOLS ACCESSORIES

HAND TOOLS / COMBINATION SETS

Cutting Metal

Metal Cutter Blades, Abrasive Cut-off wheel for Powercutter & Cut-Off Saw / Band Saw Blades / Threaded Road Cutter and Shear and Nibbler Accessories



Makita

No. B-69456
HT 150mmx1.1mmx20mm
n max. 4,680min⁻¹



Makita

405x3x25.4mm
16" x 1/8" x 1"
A-87694

max.72m/s
(4300 m/min)
max.3380min⁻¹
(3380rpm)

01048



Metal Cutting Saw Blades

Efficut Saw blades for Metal Cutter



Designed with the Efficut specific tip shape that allows for increased cutting speed, smoother cuts and more cuts per charge when paired with your Makita cordless metal cutting saws.

- The Efficut saw blades are 2.5 times faster compared to standard saw blades.
- The new tip design reduces contact with the material, increases efficiency of release waste and has a sharper bevel angle.
- Cuts are more efficient and makes your battery last longer than compared to a standard blade.



EFFICUT
Metal 7

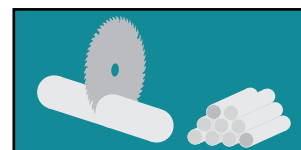

MORE CUTS PER CHARGE



FAST CUTTING



LONGER LIFE

Blade Dia (mm)	Suitable for Models	(Bore) Hole dia. (mm)	(Kerf) Tip Thickness (mm)	Plate (mm)	Hook Angle (deg)	No. of teeth	Material	Part No.
150	DCS553	20	1.1	0.95	0	33	Metal	B-69440
150	DCS553	20	1.1	0.95	0	48	Metal & SUS	B-69456

BATTERY /
CHARGERS

FIXING FASTENING
(SCREWDRIVER BITS
/ IMPACT SOCKETS)

DRILLING
(WOOD / METAL/
MASONRY)

DRILLING
/ DEMOLITION
[CONCRETE]

CUTTING
[METAL]

MULTI TOOL
ACCESSORIES

DIAMOND
[CUTTING / GRINDING]

GRINDING
ACCESSORIES

SANDING
/ POLISHING
ACCESSORIES

SAWING
ACCESSORIES

ROUTERS
/ PLANERS
ACCESSORIES

CLEANERS
ACCESSORIES

HEAT GUN / LASERS
ACCESSORIES

BRAD NAILS/ PINS
STAPLER

GARDEN TOOLS
ACCESSORIES

HAND TOOLS /
COMBINATION SETS

- BATTERY / CHARGERS
- FIXING FASTENING (SCREWDRIVER BITS / IMPACT SOCKETS)
- DRILLING (WOOD / METAL/ MASONRY)
- DRILLING / DEMOLITION [CONCRETE]
- CUTTING [METAL]**
- MULTI TOOL ACCESSORIES
- DIAMOND [CUTTING / GRINDING]
- GRINDING ACCESSORIES
- SANDING / POLISHING ACCESSORIES
- SAWING ACCESSORIES
- ROUTERS / PLANERS ACCESSORIES
- CLEANERS ACCESSORIES
- HEAT GUN / LASERS ACCESSORIES
- BRAD NAILS/ PINS STAPLER
- GARDEN TOOLS ACCESSORIES
- HAND TOOLS / COMBINATION SETS

Specialized Saw Blade for Metal Cutter



DCS553 (DC)



4131 (AC)



Blade Dia (mm)	Suitable for Models	(Bore) Hole dia. (mm)	(Kerf) Tip Thickness (mm)	Hook Angle (deg)	No. of teeth	Tooth Shape	Material / Application	Type	Part No.
136	DCS550	20	1.5	0	30	MTCG	Mild steel	-	B-07319
150	DCS553	20	1.5	0	32	MTCG	Mild steel	-	B-46296
150	DCS553	20	1.1	0	60	SMTCG	Stainless/Mild steel	Laser Slit	B-47014
185	4131	20	1.9	0	36	ATB	Mild steel (2 - 6mm)	A	B-04628
185	4131	20	2.0	0	48	MTCG	Thin mild steel (2 - 4mm)	-	A-83967
185	4131	20	1.7	-10	70	FTG	Corrugated thin plate (Less than 2mm)	-	A-86446

A: Cermet tip type (Ceramic / Metal), Long Life

Carbide-Tipped Metal Blades for Many Applications with Metal Cutter DCS551 / DCS553

		PIPE	CHANNEL	TUBING	METAL SHEET			
		STEEL	STEEL	STAINLESS STEEL	STEEL	STAINLESS STEEL	STAINLESS STEEL	
PART NO.	SIZE (MM)	THICKNESS	ø25 t=1.2mm	40x45mm t=1.6mm	40x45mm t=1.6mm	30x30mm t=1.5mm	30x30mm t=1.5mm	t=1.5mm
B-46296	150mm x 32T		●	●	✕	●	✕	✕
B-47014	150mm x 60T (CERMET TIP)		✕	✕	○	✕	●	●

Metal Cutting Saw Blades Cutting Tips

*** Secure the workpiece to a stable platform**

When cutting a long workpiece, always use support to minimize the risk of blade pinching and kickback. It is important to support the workpiece properly to minimize the risk of injury and damage to the teeth of the saw blade.

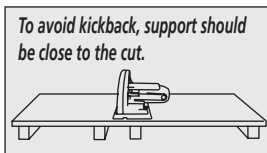
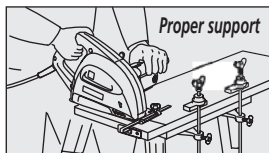

*** Always use metal cutting saw blades appropriate for your job**

The use of inappropriate saw blades may cause a poor cutting performance and present a risk of personal injury.

*** Adjust the cutting depth to the thickness of the workpiece**

Less than a full tooth of the blade should be exposed below workpiece.

*** The base should be placed on the workpiece flat and firmly**

No plunge cutting.

*** Keep your cutting line straight and your speed constant**

Too slow cutting result in premature blade worn-out.

Never twist nor force the tool while cutting.



Caution ! Always wear safety glasses, gloves, protective equipment and follow instructions provided with power tool. Do not touch blade or workpiece immediately after cut.

Metal Cutting Saw (LC1230) Accessories

Specialized Saw Blade for Portable Cut-Off



LC1230 (AC)



Blade Dia (mm)	Suitable for Models	(Bore) Hole dia. (mm)	(Kerf) Tip Thickness (mm)	Hook Angle (deg)	No. of teeth	Tooth Shape	Material / Application	Type	Part No.
305	LC1230	25.4	2.4	0	60	TCG	For cutting mild steel	Laser slit	A-86723
305	LC1230	25.4	2.4	0	78	MTCG	For thinner mild steel	-	A-87127
305	LC1230	25.4	2.3	0	76	-	For stainless steel	-	A-87579
305	LC1230	25.4	2.1	0	60	TCG	For mild steel	-	A-87242

BATTERY / CHARGERS

FIXING FASTENING (SCREWDRIVER BITS / IMPACT SOCKETS)

DRILLING (WOOD / METAL / MASONRY)

DRILLING / DEMOLITION [CONCRETE]

CUTTING [METAL]

Carbide-Tipped Metal Blades for Many Applications with Metal Cutting Saw LC1230



PART NO.	SIZE (MM)	MATERIAL	TIP THICKNESS	NOMINAL THICKNESS								
				6 mm	4 mm	3 mm	4.5 mm	2.3 mm	3.2 mm	3.8 mm	4 mm	1.5 mm
A-87242	305 x 60T	Mild steel	2.1 mm	○	○	○	△	×	●	●	×	×
A-86723	305 x 60T	Mild steel (LESS NOISE)	2.4 mm	●	●	●	○	×	●	●	×	×
A-87127	305 x 78T	Thin steel	2.3 mm	△	△	△	×	○	△	△	×	×
A-87579	305 x 76T	Stainless steel	1.95 mm	○	○	△	×	●	△	●	○	○

● Excellent ○ Good △ Fair × Not Applicable

MULTI TOOL ACCESSORIES

DIAMOND [CUTTING / GRINDING]

GRINDING ACCESSORIES

SANDING / POLISHING ACCESSORIES

SAWING ACCESSORIES

ROUTERS / PLANERS ACCESSORIES

CLEANERS ACCESSORIES

Aluminium Composite (CA5000XJ) Accessories

Specialized Blade for Aluminium composite

CA5000XJ (AC)



Blade Dia (mm)	Suitable for Models	(Bore) Hole dia. (mm)	Plate (mm)	(Kerf) Tip Thickness (mm)	Hook Angle (deg)	No. of teeth	Tooth Shape	Part No.
118	CA5000XJ	20	6	14	5	6	90°	B-48832
118	CA5000XJ	20	6	18	5	6	135°	B-48860

HEAT GUN / LASERS ACCESSORIES

BRAD NAILS / PINS STAPLER

GARDEN TOOLS ACCESSORIES

HAND TOOLS / COMBINATION SETS

- BATTERY / CHARGERS
- FIXING FASTENING (SCREWDRIIVER BITS / IMPACT SOCKETS)
- DRILLING (WOOD / METAL/ MASONRY)
- DRILLING / DEMOLITION (CONCRETE)
- CUTTING [METAL]**
- MULTI TOOL ACCESSORIES
- DIAMOND [CUTTING / GRINDING]
- GRINDING ACCESSORIES
- SANDING / POLISHING ACCESSORIES
- SAWING ACCESSORIES
- ROUTERS / PLANERS ACCESSORIES
- CLEANERS ACCESSORIES
- HEAT GUN / LASERS ACCESSORIES
- BRAD NAILS/ PINS STAPLER
- GARDEN TOOLS ACCESSORIES
- HAND TOOLS / COMBINATION SETS

Portable Band Saw Accessories

Portable Band Saw Blades



For Model : DPB180 / 2106/ 2106W / 2107FK

Blade type	WX L (mm)	Thickness (mm)	Thickness of work piece	Teeth Per Inch (TPI)	Application	Pcs per package	Part No.
Carbon steel	1140 x 13mm	0.5	-	6	Wood	3	792567-9
Carbon steel	1140 x 13mm	0.5	More than 5mm	14	Plastics and non ferrous metals. Mild steel, cast steel and cast iron	3	792560-3
Carbon steel	1140 x 13mm	0.5	4 - 5mm	18		3	792559-8
Carbon steel	1140 x 13mm	0.5	Less than 4mm	24		3	792558-0
Bi-Metal	1140 x 13mm	0.5	More than 5mm	14	Plastics and non ferrous metals. Mild steel, cast steel and cast iron. Hard steel and stainless steel	1	792557-2
Bi-Metal	1140 x 13mm	0.5	4 - 5mm	18		1	792556-4
Bi-Metal	1140 x 13mm	0.5	Less than 4mm	24 WAVE TEETH		1	194692-6

For Model: DPB181 / DPB182 / DPB183

Blade type	WX L (mm)	Thickness (mm)	Thickness of work piece	Teeth Per Inch (TPI)	Application	Pcs per package	Part No.
Bi-Metal	835 x 13mm	0.5	3mm-6 mm	14 WAVE TEETH	Plastics and non-ferrous metal. Mild steel, cast steel and cast iron. Hard steel and stainless steel.	5	B-40543
Bi-Metal	835 x 13mm	0.5	2 mm- 3 mm	18 WAVE TEETH		5	B-40559
Bi-Metal	835 x 13mm	0.5	less than 2mm	24 WAVE TEETH		5	B-40565

Portable Band Saw Stand / Cover and Wax

For accurate square cutting operations

Blade type	Width x Length (mm)		Part No.
2106	Portable band saw stand	<p>Stand Cover Wax</p>	STEX122370
2107FK	Portable band saw stand		194026-3
2107FK	Cover		194070-0
2107FK	Portable band saw stand & Cover set		194069-5
DPB181	Cover		197975-3
Cutting Wax For Portable Band Saw			191897-9

Portable Cut-Off Accessories

Abrasive cut-off wheel (for Portable Cut-off)

- 3mm thickness
- For all ferrous materials - Steel, Cast iron and other hard metals



Size (mm)	Grit	Type	Pc Per Pkg	Max. RPM	Part No.
305 x 3.0 x 25.4	A36P	Smooth	25	4,500	A-87650-25
355 x 3.0 x 25.4	A36P	Smooth	25	3,900	A-87672-25
405 x 3.0 x 25.4	A36P	Smooth	25	3,380	A-87694-25

Power Cutter Accessories

Abrasive cut-off wheel (For power cutter)

- Always ensure the max RPM of the wheel matches the power cutter



Size (mm)	Grit	Max. RPM	Part No.
230 x 2.0 x 22.23	Metal	6600 min ⁻¹	D-18792
300 x 3.5 x 20 mm	Metal	5100 min ⁻¹	B-70792
350 x 4.0 x 25.4 mm	Metal	5500 min ⁻¹	B-70839
350 x 4.0 x 25.4 mm	Stone	5500 min ⁻¹	B-70823

Trolley kit (For power cutter)

A: Trolley with water attachment kit



Trolley	For Models	Type	Part no
DT2010	EK7301	A	394369600
DT4000	EK7650H / EK7651H	A	394369610
Water attachment kit	EK7301	-	394365602

Pressurised Metal Water Tank (For power cutter)

The Pressurised Water Tank makes applications like wet cutting possible in areas where water is limited or unavailable.

Portable and Easy to Operate



Max Operation Pressure:	Max water capacity	Part no
6 Bar	10 Litres	957802600

BATTERY / CHARGERS

FIXING FASTENING (SCREWDRIVER BITS / IMPACT SOCKETS)

DRILLING (WOOD / METAL / MASONRY)

DRILLING / DEMOLITION [CONCRETE]

CUTTING [METAL]

MULTI TOOL ACCESSORIES

DIAMOND [CUTTING / GRINDING]

GRINDING ACCESSORIES

SANDING / POLISHING ACCESSORIES

SAWING ACCESSORIES

ROUTERS / PLANERS ACCESSORIES

CLEANERS ACCESSORIES

HEAT GUN / LASERS ACCESSORIES

BRAD NAILS / PINS STAPLER

GARDEN TOOLS ACCESSORIES

HAND TOOLS / COMBINATION SETS

Threaded Rod Cutters / Steel Rod Cutter Blades and Accessories

Specialized Saw Blade for Portable Cut-Off



For Model	Type	Size	Part no:
DSC121	Mild Steel - Stainless Steel	M12	SC09002720
DSC121	Mild Steel - Stainless Steel	M10	SC09002710
DSC121	Mild Steel - Stainless Steel	M8	SC09002700



For Model	Type	Size	Part no:
DSC102	Mild Steel - Stainless Steel	M6	199082-8
DSC102	Mild Steel - Stainless Steel	M8	199085-2
DSC102	Mild Steel	M10	199083-6



For Model	Type	Part no:
DCS163	Cutter blade set	SC09002470



For Model	Type	Size	Part no:
DSC251	TCT Saw Blade	110mm	SC09003260

Spacer part # SC09030550 used with DSC250 to fit the above accessory

Hole Puncher accessories

Combination of punch and die

- Punching holes through a thin structural metal plate may cause deformation of the plate and burr on the holes.
- If you need precision punching, see the tables below to select an optimum combination of punch and die.



● Round punching

○ Oblong punching



● Round punching						
Punch		Die		Cutting material		
				Tensile Mild Steel (65,000 psi)	Channel	Tensile Stainless Steel (89,000 psi)
Hole diameter (mm)	Part No.	Hole diameter (mm)	Part No.	Thickness		
6	SC05340040	SB6	SC00000203	t2-t4		t3-t4
6.5	SC05340050	SB6.5	SC00000205	t2-t6		t3-t4
8	SC05340060	SB8	SC00000207	t2-t6		t3-t4
8.5	SC05340070	SB8.5	SC00000209	t2-t6		t3-t4
10	SC05340080	SB10	SC00000211	t2-t6	t7.5	t3-t4
11	SC05340090	SB11	SC00000213	t2-t8	t7.5	t3-t6
12	SC05340100	SB12	SC00000215	t2-t8	t7.5	t3-t6
13	SC05340110	SB13	SC00000217	t2-t8	t7.5	t3-t6
14	SC05340120	SB14	SC00000219	t2-t8	t7.5	t3-t6
15	SC05340130	SB15	SC00000221	t2-t8	t7.5	t3-t6
16	SC05340140	SB16	SC05332710	t2-t8	t7.5	t3-t6
18	SC05340150	SB18	SC00000223	t2-t8	t7.5	t3-t6
20	SC05340160	SB20	SC05352510	t2-t8	t7.5	t3-t6

○ Oblong punching						
Punch		Die		Cutting material		
				Tensile Mild Steel (65,000 psi)	Channel	Tensile Stainless Steel (89,000 psi)
Hole diameter (mm)	Part No.	Hole diameter (mm)	Part No.	Thickness		
6.5 x 10	SC05340200	6.5 x 10B	SC00000244	t2-t6		t3-t4
6.5 x 13	SC05340210	6.5 x 13B	SC00000246	t2-t6		t3-t4
8.5 x 13	SC05340220	8.5 x 13B	SC00000248	t2-t6		t3-t4
8.5 x 17	SC05340230	8.5 x 17B	SC00000250	t2-t6		t3-t4
9 x 13.5	SC05340240	9 x 13.5B	SC00000252	t2-t6		t3-t4
9 x 18	SC05340250	9 x 18B	SC00000254	t2-t6		t3-t4
10 x 15	SC05340260	10 x 15B	SC00000256	t2-t8	t7.5	t3-t6
10 x 20	SC05340270	10 x 20B	SC00000258	t2-t8	t7.5	t3-t6
11 x 16.5	SC05340280	11 x 16.5B	SC00000260	t2-t8	t7.5	t3-t6
12 x 18	SC05340290	12 x 18B	SC00000262	t2-t8	t7.5	t3-t6
13 x 19.5	SC05340300	13 x 19.5B	SC00000264	t2-t8	t7.5	t3-t6
14 x 21	SC05340310	14 x 21B	SC00000266	t2-t8	t7.5	t3-t6

Stand

- Used with Hole Puncher



Work stand
Allows the tool to be stationed over a flat surface



Slide stopper
Allows the workpiece to be positioned up to 40mm from the edge



For model	Type	Part No.
DPP200	A	SC03801080
DPP200	B	SC03300790

Oil

- Used with Threaded Rod Cutters / Hole Puncher



For model	Size	Type	Part No.
DSC163, DPP200	35mL	A	SC00000106
DSC163, DPP200	1,000mL	B	SC00000270

- BATTERY / CHARGERS
- FIXING FASTENING (SCREWDRIVER BITS / IMPACT SOCKETS)
- DRILLING (WOOD / METAL / MASONRY)
- DRILLING / DEMOLITION (CONCRETE)
- CUTTING [METAL]
- MULTI TOOL ACCESSORIES
- DIAMOND [CUTTING / GRINDING]
- GRINDING ACCESSORIES
- SANDING / POLISHING ACCESSORIES
- SAWING ACCESSORIES
- ROUTERS / PLANERS ACCESSORIES
- CLEANERS ACCESSORIES
- HEAT GUN / LASERS ACCESSORIES
- BRAD NAILS/ PINS STAPLER
- GARDEN TOOLS ACCESSORIES
- HAND TOOLS / COMBINATION SETS

Shear and Nibbler accessories

Shear accessories

Shear Head Assembly

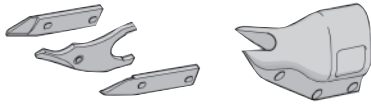

For Model	Part No
JS1300	125112-9

Shear Blade Set

Two per set in blister pack

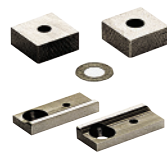

For Model	Part No
JS1600, JS1602	191383-0
JS1660, JS1601, DJS101	792533-6
JS3200, JS3201	792287-5

Side Blade

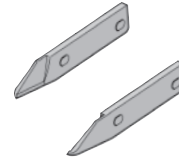

For Model	Part No
JS1300 (R)	792742-7
JS1300 (L)	792743-5

Center Blade



For Model	Part No
JS1300	792744-3
JS1660, JS1601, DJS101	792534-4

Thickness Gauge



To set blades at the proper gap

For Model	Part No
JS3200, JS3201	762007-1
JS1660, JS1601	762013-6

BATTERY /
CHARGERS

FIXING FASTENING
(SCREWDRIVER BITS
/ IMPACT SOCKETS)

DRILLING
(WOOD / METAL/
MASONRY)

DRILLING
/ DEMOLITION
(CONCRETE)

CUTTING
[METAL]

MULTI TOOL
ACCESSORIES

DIAMOND
(CUTTING / GRINDING)

GRINDING
ACCESSORIES

SANDING
/ POLISHING
ACCESSORIES

SAWING
ACCESSORIES

ROUTERS
/ PLANERS
ACCESSORIES

CLEANERS
ACCESSORIES

HEAT GUN / LASERS
ACCESSORIES

BRAD NAILS/ PINS
STAPLER

GARDEN TOOLS
ACCESSORIES

HAND TOOLS /
COMBINATION SETS

Nibbler Accessories

Punch

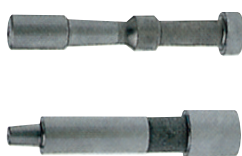

For Model	Part No
JN1601, DJN161	A-83951
JN3200, JN3201	792728-1

Die

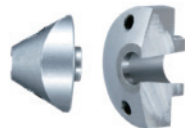

For Model	Part No
JN101, DJN161	A-15051
JN3200, JN3201	792292-2

Washer

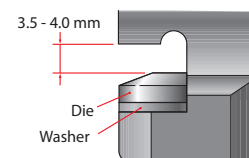

To keep clearance of 3.5 to 4.0mm, use a washer or two under the die when installing a resharpened die.

For Model	Part No
JN3200, JN3201	341796-7

Wrench



For Model	Part No
JN3200, JN3201	781019-5

Hex Wrench



For Model	Size	Part No
JN3200, JN3201, JS1660, JS1601, JS1602	3.0mm	783201-2
JN1601	2.5mm	783208-8

- BATTERY / CHARGERS
- FIXING FASTENING (SCREWDRIVER BITS / IMPACT SOCKETS)
- DRILLING (WOOD / METAL/ MASONRY)
- DRILLING / DEMOLITION [CONCRETE]
- CUTTING [METAL]**
- MULTI TOOL ACCESSORIES
- DIAMOND [CUTTING / GRINDING]
- GRINDING ACCESSORIES
- SANDING / POLISHING ACCESSORIES
- SAWING ACCESSORIES
- ROUTERS / PLANERS ACCESSORIES
- CLEANERS ACCESSORIES
- HEAT GUN / LASERS ACCESSORIES
- BRAD NAILS/ PINS STAPLER
- GARDEN TOOLS ACCESSORIES
- HAND TOOLS / COMBINATION SETS

Tile Cutter Accessories

Ware supply pipe for Cutter



For Model	Part No.
4100NH	164405-9
4101RH	153409-6
4107R, 4107RH	164350-8
4140	153555-5

Vinyl tube for Cutter



For Model	Size(mm)	Part No.
4100NH, 4101RH, 4140	5 x 7 x5,000	412010-9
4107R, 4107RH	5 x 9 x5,000	412028-0

Dust bag assembly

For Dustless cutter



Suitable for	Part No.
4105KB	123185-6

Rip Fence (Guide Rule)

4101RH (Use with **924206-5** Wing bolt M5 X 10)
4131 (Use with **265701-9** Wing bolt M6 X 14)



For Model	Part No.
4191D, 4100NH, 4101RH, 4131, DCS550Z,	164095-8

Wrenches

Wrench / Socket / Hex Wrench

- Used with Cutters / Portable cutt-off, Wall chaser, Hole puncher, Rod cutter

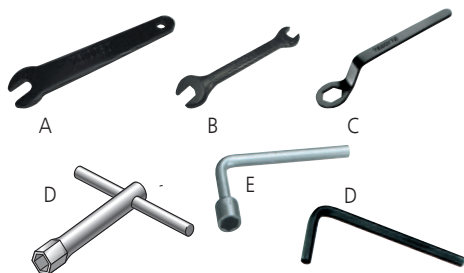

For model	Size	Type	Part No.
4105KB, 4140 / 4100NH	22	A	781011-1
4107R	22	C	782017-2
4100NH, 4100NB, 4140, 9308	9	D	782209-3
4107R	13	E	782212-4
2414 / 2414B / 2414NB / 2416S / 4131 / LC1230	17	D	782210-8
SG1250 / SG1251	6	F	783204-6

MULTI TOOL ACCESSORIES

STAR LOCK SERIES / SANDING PAD

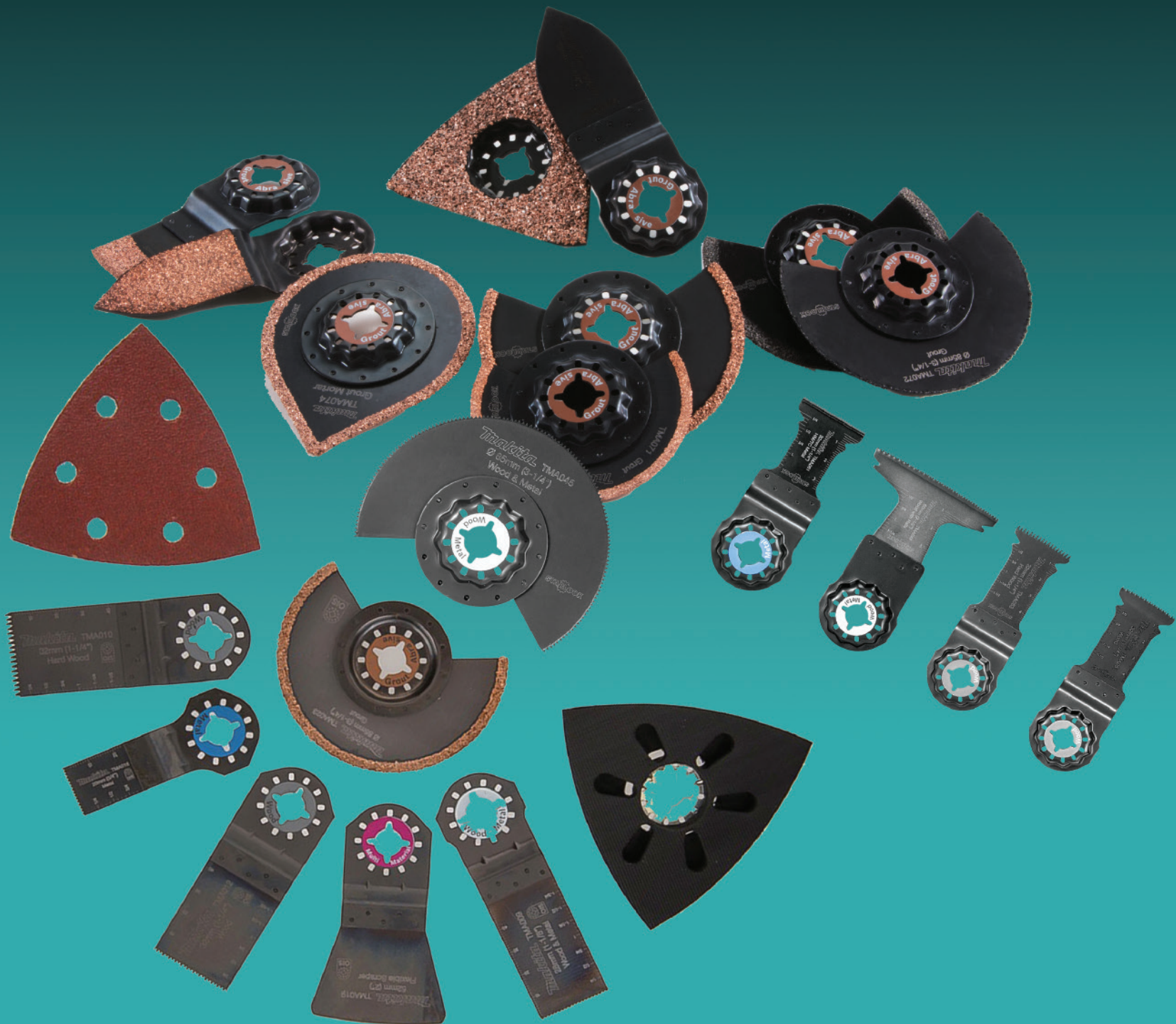



Color coding for application

Rating Suitability for application:

AA = Especially Suitable

A = Suitable

n. r = No Rating

Width (mm)	Teeth per inch	Blade Material	Curve Teeth	Japan Teeth	Wood & Metal								
					Wood				Metal				
					Wood	Plywood	Chipboard	Plaster board	Non ferrous metal	Sheet metal	Stainless	Soft nail	

Sawing

TMA045	85	18	BiM			AA	AA	AA	A	AA	A	n. r	AA
TMA046	100	15	BiM			AA	AA	AA	A	A	n. r	n. r	n. r
TMA049	85	18	HCS			A	A	n. r	n. r	n. r	n. r	n. r	n. r
TMA064	85	18	BiM			AA	AA	AA	AA	AA	A	n. r	AA

Plung Cutting

TMA047	32	20	BiM	●		AA	AA	AA	A	A	AA	n. r	AA
TMA048	65	20	BiM	●		AA	AA	AA	AA	A	A	n. r	AA
TMA050	24	18	HCS			A	A	A	n. r	n. r	n. r	n. r	n. r
TMA051	32	18	HCS	●		A	A	A	n. r	n. r	n. r	n. r	n. r
TMA052	65	20	HCS	●		A	A	A	n. r	n. r	n. r	n. r	n. r
TMA053	32	14	BiM	●	●	AA	AA	AA	A	n. r	n. r	n. r	n. r
TMA054	32	14	HCS	●	●	A	A	n. r	n. r	n. r	n. r	n. r	n. r
TMA055	65	14	BiM	●	●	AA	AA	AA	A	n. r	n. r	n. r	n. r
TMA056	65	14	HCS	●	●	A	A	n. r	n. r	n. r	n. r	n. r	n. r
TMA057	10	20	BiM			AA	AA	AA	AA	AA	AA	n. r	AA
TMA058	20	20	BiM			AA	AA	AA	AA	AA	AA	n. r	AA
TMA059	32	20	BiM			A	A	A	AA	AA	AA	n. r	AA
TMA060	20	23	TC			A	A	A	AA	AA	AA	n. r	AA
TMA061	32	23	TC			A	A	A	AA	AA	AA	AA	AA
TMA079	45	23	TC			A	A	A	AA	AA	A	A	A
TMA080	32	20	TC	●		A	A	A	AA	AA	A	A	A
TMA081	53	14	BiM	●		n. r	A	AA	AA	n. r	n. r	n. r	A

Scraping

TMA065	52	-	HCS			n. r	n. r	n. r	n. r	n. r	n. r	n. r	n. r
TMA066	52	-	HCS			n. r	n. r	n. r	n. r	n. r	n. r	n. r	n. r

Cutting

TMA063	100	-	BiM			n. r	n. r	n. r	n. r	n. r	n. r	n. r	n. r
TMA067	28	-	HCS			n. r	n. r	n. r	n. r	n. r	n. r	n. r	n. r
TMA082	12	-	Stainless			n. r	n. r	n. r	n. r	n. r	n. r	n. r	n. r
TMA068	11	-	HCS			n. r	n. r	n. r	n. r	n. r	n. r	n. r	n. r
TMA070	85	-	Diamond			n. r	n. r	n. r	A	n. r	n. r	n. r	n. r

Removing

TMA074	70	-	TC #40			n. r	n. r	n. r	A	n. r	n. r	n. r	n. r
TMA076	32	-	TC #40			n. r	n. r	n. r	n. r	n. r	n. r	n. r	n. r
TMA077	32	-	TC #100			n. r	n. r	n. r	n. r	n. r	n. r	n. r	n. r

Routing

TMA069	85	-	TC #30			n. r	n. r	n. r	A	n. r	n. r	n. r	n. r
TMA071	70	-	TC #50			n. r	n. r	n. r	A	n. r	n. r	n. r	n. r
TMA072	85	-	TC #40			n. r	n. r	n. r	A	n. r	n. r	n. r	n. r
TMA074	70	-	TC #40			n. r	n. r	n. r	n. r	n. r	n. r	n. r	n. r
TMA075	32	-	TC #50			n. r	n. r	n. r	n. r	n. r	n. r	n. r	n. r

Sanding

TMA073	78	-	TC #20			n. r	n. r	n. r	n. r	n. r	n. r	n. r	n. r
TMA076	32	-	TC #40			AA	n. r	n. r	n. r	n. r	n. r	n. r	n. r
TMA077	32	-	TC #100			AA	n. r	n. r	n. r	n. r	n. r	n. r	n. r
TMA083	90	-	TC #20			A	A	A	n. r	n. r	n. r	n. r	n. r
TMA084	90	-	TC #40			A	A	A	n. r	n. r	n. r	n. r	n. r
TMA085	90	-	TC #60			AA	AA	AA	n. r	n. r	n. r	n. r	n. r
TMA086	90	-	TC #100			AA	AA	AA	n. r	n. r	n. r	n. r	n. r



Multi Tool Accessories

Wide selection of accessories for various applications

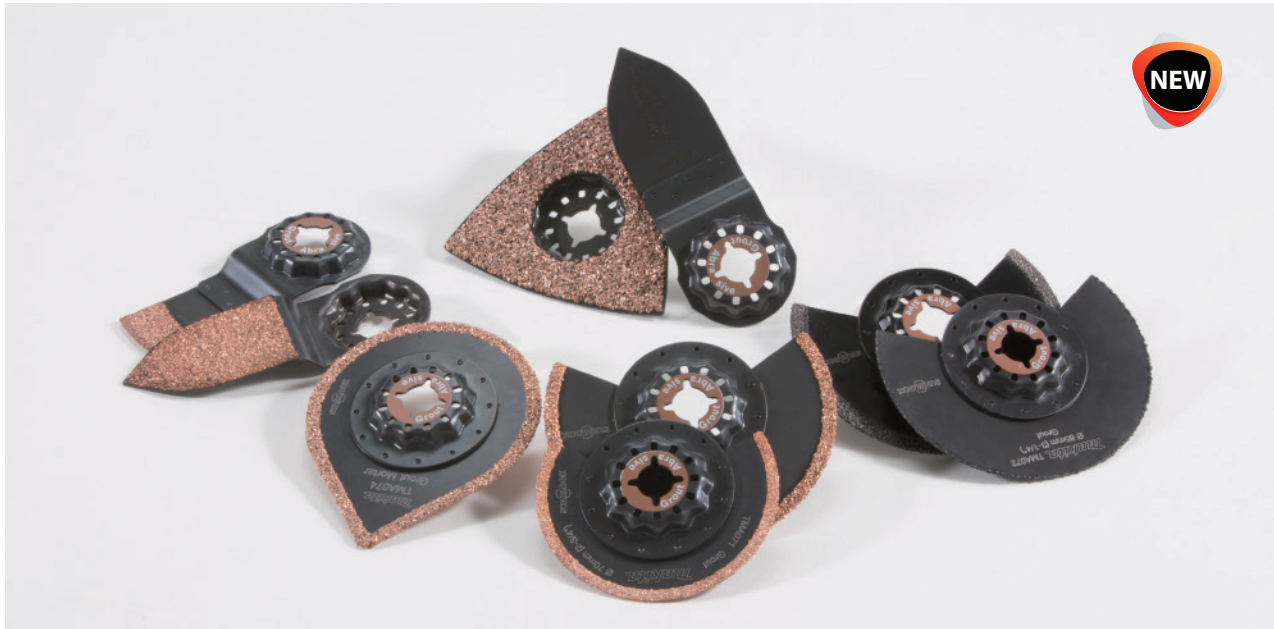

BATTERY / CHARGERS

FIXING FASTENING (SCREWDRIVER BITS / IMPACT SOCKETS)

DRILLING (WOOD / METAL / MASONRY)

DRILLING / DEMOLITION [CONCRETE]

CUTTING [METAL]

MULTI TOOL ACCESSORIES

DIAMOND [CUTTING / GRINDING]

GRINDING ACCESSORIES

SANDING / POLISHING ACCESSORIES

SAWING ACCESSORIES

ROUTERS / PLANERS ACCESSORIES

CLEANERS ACCESSORIES

HEAT GUN / LASERS ACCESSORIES

BRAD NAILS/ PINS STAPLER

GARDEN TOOLS ACCESSORIES

HAND TOOLS / COMBINATION SETS

Plunge Cutting

Applications:
Cutting of various materials such as oak wood, drywalls, plastics, copper pipes, non-hardened nails, etc.

Benefits:

- Different from jigsaws, able to make a plunge cut in the wall for electrical connection box, lighting, exhaust fan, etc.
- The blade can be positioned in twelve different angles to allow easy operation in tight spaces.



Cutting

Applications:
Cutting of various materials such as oak wood, drywalls, plastics, copper pipes, non-hardened nails, etc.

Benefits:

- Able to perform long distance push cut.
- The segment shape allows flush cutting



Sanding

Applications:
Sanding wood, stone and paint removal, etc. with a full range of abrasive papers.

Benefits:

- Able to sand in corners.
- Quick hook and loop fastening.
- Polishing pads also available.
- Connectable to vacuum cleaner with optional dust



Removing Grout / Cutting Tiles

Applications:
Replacing broken wall, floor tile removal, grout and adhesive removal.

Benefits:

- Less amount of dust scattering thanks to oscillating action.
- The segment shape allows flush cutting and cutting into corners



Scraping

Applications:
Removing mortar, tile adhesive, hardened glue, window putty, caulking, paint, etc.

Benefits:
Low-profile blade with a narrow tip allows easy removal of caulking, window putty, etc



Segment saw blade 85

TMA045

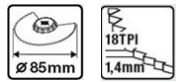

Application/ Recommended Use
Wood&Metal/ Suitable for flush cutting
Cut-off door frame to length on the floor
Cut-out parquet/laminate flooring
Cut-off smaller mouldings to length

Diameter (mm)	Type	Per pkg.	Part No.
85	BiM, Wood&Metal	1	B-64799

Segment saw blade 100

TMA046

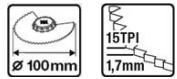

Application/ Recommended Use
Wood&Metal/ Suitable for deep cutting
Cut-off door frame to length on the floor
Cut-out parquet/laminate flooring
Cut-off smaller mouldings to length

Diameter (mm)	Type	Per pkg.	Part No.
100	BiM, Wood&Metal	1	B-64808

Segment saw blade 85

TMA049

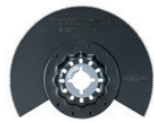
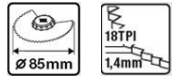

Application/ Recommended Use
Wood/ Suitable for flush cutting
Plunge-cut in solid wood
Cut-off plastic pipe(PVC) to length

Diameter (mm)	Type	Per pkg.	Part No.
85	HCS, Wood	1	B-64836

Segment saw blade 85

TMA064

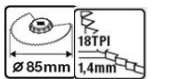

Application/ Recommended Use
Non-ferrous metal, FRP, PVC / Suitable for corners.
Plunge cut in plasterboard or cement-bonded fiber boards
Cut-off smaller mouldings to length
Cutting recesses in epoxy/glass fiber reinforced plastic

Diameter (mm)	Type	Per pkg.	Part No.
85	BiM-TiN, Multi Material	1	B-64973

Bow Shape plunge cut saw blade 32

TMA047

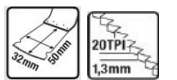

Application/ Recommended Use
Wood and Metal / Suitable for Precisely plunge cut
Plunge cut in hardwood

Size (mm)	Type	Per pkg.	Part No.
32 x 50	BiM, Wood&Metal	1	B-64814

Bow Shape plunge cut saw blade 65

TMA048



Application/ Recommended Use
Wood and nails/ Suitable for plunge cutting
Cutting wood with nails
Cutting a door frame to length
Plunge cuts in laminated panels

Size (mm)	Type	Per pkg.	Part No.
65 x 40	BiM, Wood&Metal	1	B-64820

Plunge cut saw blade 24

TMA050



Application/ Recommended Use
Wood
Plunge-cut in softwood
Cutting a recess in furniture components
Flush cutting wooden components to length

Size (mm)	Type	Per pkg.	Part No.
24 x 50	HCS, Wood	1	B-64842

Bow Shape plunge cut saw blade 32

TMA051

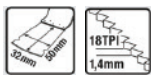

Application/ Recommended Use
Wood/ Suitable for Precisely plunge cut
Cutting a recess in furniture components
Plunge-cut in softwood

Size (mm)	Type	Per pkg.	Part No.
32 x 50	HCS, Wood	1	B-64858

Bow Shape plunge cut saw blade 32

TMA053



Application/ Recommended Use
Hard Wood/ Suitable for Precisely plunge cut
Plunge cut in hardwood
Cutting a recess in furniture components
Plunge cut in laminate panels

Diameter (mm)	Type	Per pkg.	Part No.
32 x 50	BiM, Wood	1	B-64870

Plunge cut saw blade 10

TMA057



Application/ Recommended Use
Metal/ Suitable for flush cutting in nails or plasterboard
Filigree adjustment work on non-ferrous profiles
Plunge cuts in plasterboard

Diameter (mm)	Type	Per pkg.	Part No.
10 X 30	BiM, Wood	1	B-64917

BATTERY / CHARGERS

FIXING FASTENING (SCREWDRIVER BITS / IMPACT SOCKETS)

DRILLING (WOOD / METAL/ MASONRY)

DRILLING / DEMOLITION (CONCRETE)

CUTTING (METAL)

MULTI TOOL ACCESSORIES

DIAMOND (CUTTING / GRINDING)

GRINDING ACCESSORIES

SANDING / POLISHING ACCESSORIES

SAWING ACCESSORIES

ROUTERS / PLANERS ACCESSORIES

CLEANERS ACCESSORIES

HEAT GUN / LASERS ACCESSORIES

BRAD NAILS/ PINS STAPLER

GARDEN TOOLS ACCESSORIES

HAND TOOLS / COMBINATION SETS

BATTERY / CHARGERS

FIXING FASTENING (SCREWDRIVER BITS / IMPACT SOCKETS)

DRILLING (WOOD / METAL / MASONRY)

DRILLING / DEMOLITION (CONCRETE)

CUTTING [METAL]

MULTI TOOL ACCESSORIES

DIAMOND [CUTTING / GRINDING]

GRINDING ACCESSORIES

SANDING / POLISHING ACCESSORIES

SAWING ACCESSORIES

ROUTERS / PLANERS ACCESSORIES

CLEANERS ACCESSORIES

HEAT GUN / LASERS ACCESSORIES

BRAD NAILS / PINS STAPLER

GARDEN TOOLS ACCESSORIES

HAND TOOLS / COMBINATION SETS

Plunge cut saw blade 20

TMA058

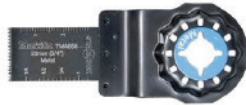
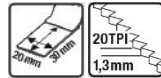

Application/ Recommended Use

Metal/ Suitable for flush cutting in nails or copper pipe
Plunge cuts in plasterboard

Diameter (mm)	Type	Per pkg.	Part No.
20 x 30	BiM, Metal	1	B-64923

Plunge cut saw blade 32

TMA059



Application/ Recommended Use

Metal/ Suitable for flush cutting in nails or copper pipe
Plunge cuts in plasterboard

Diameter (mm)	Type	Per pkg.	Part No.
32 x 50	BiM, Metal	1	B-64939

TC Bar plunge cut saw blade 45

TMA079



Application/ Recommended Use

Metal/ Suitable for flush cutting in nails or copper pipe
Plunge cuts in plasterboard

Diameter (mm)	Type	Per pkg.	Part No.
45 x 40	TC/HM, Metal	1	B-69755

TC Bar Bow Shape plunge cut saw blade 32

TMA080



Application/ Recommended Use

Multi material/ Suitable for precisely plunge cut
Plunge cut plasterboard, fiberglass, epoxy, aluminum, stainless

Diameter (mm)	Type	Per pkg.	Part No.
32 x 40	TC/HM, Multi Material	1	B-69761

Bow Shape plunge cut saw blade 53

TMA081



Application/ Recommended Use

Multi material/ Suitable for precisely and fast plunge cut in plasterboard
1 Blade does the job of 2 (Plunge & Cut on). Cutting plasterboard, wood, epoxy

Diameter (mm)	Type	Per pkg.	Part No.
53 x 40	BiM, Multi Material	1	B-69777

Scraper 52 Rigid

TMA0651



Application/ Recommended Use

Removing mortar or tile adhesive
Removing mortar and concrete residues
Removing hard, brittle carpet adhesive residues

Diameter (mm)	Type	Per pkg.	Part No.
52 x 26	HCS	1	B-64989

Scraper 52 Flexible

TMA066



Application/ Recommended Use

Removing soft carpet adhesive residues
Removing paint residues
Removing silicone joints

Diameter (mm)	Type	Per pkg.	Part No.
52 x 40	HCS	1	B-64995

General Joint Cutter

TMA067



Application/ Recommended Use

Cutting soft expansion joints
Cutting window putty
Cutting insulation materials

Diameter (mm)	Type	Per pkg.	Part No.
28 x 40	HCS	1	B-65006

Universal Purpose Knife

TMA082



Application/ Recommended Use

Cutting teaksealant, caulking material

Size (mm)	Type	Per pkg.	Part No.
12 x 29	Stainless	1	B-69783

TC Remover

TMA074

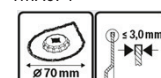

Application/ Recommended Use

Routing joints on wall and floor tiles
Removing mortar or tile adhesive
Removing joints in the smallest of corners with the tungsten carbide tip

Diameter (mm)	Type	Per pkg.	Part No.
70	TC/HM grit #40	1	B-65078

TC Seg Saw Blade 85

TMA069

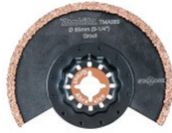
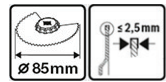

Application/ Recommended Use

Routing joints on wall and floor tiles
Smaller cutouts in soft wall tiles
Routing grooves in porous concrete, for laying concealed cables and pipes

Diameter (mm)	Type	Per pkg.	Part No.
85	TC/HM grit #30	1	B-65028

TC Seg Saw Blade 70

TMA071

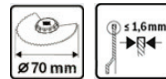

Application/ Recommended Use

Routing extra-thin 1/16" joints on wall tiles
Routing recesses in epoxy/glass fiber reinforced plastic
Routing grooves in porous concrete, for laying concealed cables and pipes

Diameter (mm)	Type	Per pkg.	Part No.
70	TC/HM grit #50	1	B-65040

Diamond Seg Saw blade 85

TMA070

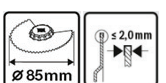

Application/ Recommended Use

Cutout of soft wall tiles and FRP
Routing recesses in epoxy/glass fiber reinforced plastic
Routing joints on wall tiles

Diameter (mm)	Type	Per pkg.	Part No.
85	Diamond grit #40	1	B-65034

TC Sanding Plate 78

TMA073

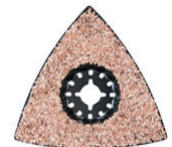

Application/ Recommended Use

Removing mortar or tile adhesive
Removing carpet adhesive residues from a mineral surface

Size (mm)	Type	Per pkg.	Part No.
78	TC/HM grit #20	1	B-65062

TC Sanding Plate 90

TMA083



Application/ Recommended Use

Removing mortar, tile adhesive, paint on fiberglass
Removing carpet adhesive residues from a mineral surface

Size (mm)	Type	Per pkg.	Part No.
90	TC/HM grit #20	1	B-69799

TC Sanding Plate 90

TMA084



Application/ Recommended Use

Sanding in wood with paint, paint of fiberglass
Removing mortar, tile adhesive, carpet adhesive residues from a mineral surface

Size (mm)	Type	Per pkg.	Part No.
90	TC/HM grit #40	1	B-69808

TC Sanding Plate 90

TMA085

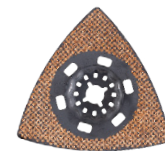

Application/ Recommended Use

Sanding in wood, wood with paint roughly

Size (mm)	Type	Per pkg.	Part No.
90	TC/HM grit #60	1	B-69814

TC Sanding Plate 90

TMA086

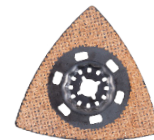

Application/ Recommended Use

Sanding in wood for fine surfaces

Diameter (mm)	Type	Per pkg.	Part No.
90	TC/HM grit #100	1	B-69820

Sanding pad

TMA078

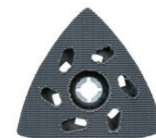

Application/ Recommended Use

Use with Riff sanding pad

Diameter (mm)	Type	Per pkg.	Part No.
93	hook & loop	1	B-65115

Multi tool Starlock Blade Set (with Tool box)



The components of each set are packed in tool box complete.
Tool box can insert to the plastic case of TM3010C and DTM51

Type	Part No.
TMA045, TMA047, TMA053, TMA058, TMA078	199542-0

BATTERY /
CHARGERS

FIXING FASTENING
(SCREWDRIVER BITS
/ IMPACT SOCKETS)

DRILLING
(WOOD / METAL/
MASONRY)

DRILLING
/ DEMOLITION
[CONCRETE]

CUTTING
[METAL]

MULTI TOOL
ACCESSORIES

DIAMOND
[CUTTING / GRINDING]

GRINDING
ACCESSORIES

SANDING
/ POLISHING
ACCESSORIES

SAWING
ACCESSORIES

ROUTERS
/ PLANERS
ACCESSORIES

CLEANERS
ACCESSORIES

HEAT GUN / LASERS
ACCESSORIES

BRAD NAILS/ PINS
STAPLER

GARDEN TOOLS
ACCESSORIES

HAND TOOLS /
COMBINATION SETS

BATTERY / CHARGERS

FIXING FASTENING (SCREWDRIVER BITS / IMPACT SOCKETS)

DRILLING (WOOD / METAL / MASONRY)

DRILLING / DEMOLITION (CONCRETE)

CUTTING [METAL]

MULTI TOOL ACCESSORIES

DIAMOND [CUTTING / GRINDING]

GRINDING ACCESSORIES

SANDING / POLISHING ACCESSORIES

SAWING ACCESSORIES

ROUTERS / PLANERS ACCESSORIES

CLEANERS ACCESSORIES

HEAT GUN / LASERS ACCESSORIES

BRAD NAILS/ PINS STAPLER

GARDEN TOOLS ACCESSORIES

HAND TOOLS / COMBINATION SETS



Sawing

Segment saw blade 65

TMA002

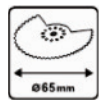

Application/ Recommended Use

Non-ferrous metal, FRP, PVC/ Suitable for corners
Cutting recesses in epoxy/glass fiber reinforced plastic
Cutting sheet metal up to 1mm
Removing old window putty

	Diam (mm)	Type	Part No.)
OIS	65	BiM-TiN, Multi Material, flat	B-21288

Sawing

Round saw blade 65

TMA004

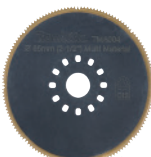
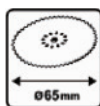

Application/ Recommended Use

Non-ferrous metal, FRP, PVC
Cutting recesses in epoxy/glass fiber reinforced plastic
Cutting sheet metal up to 1mm
Removing old window putty

	Diam (mm)	Type	Part No.)
OIS	65	BiM-TiN, Multi Material, flat	B-21303

Cutting

General Joint Cutter

TMA021

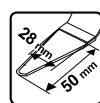

Application/ Recommended Use

Cutting soft expansion joints
Cutting window putty
Cutting insulation materials

	Diam (mm)	Type	Part No.)
OIS	28 x 50	HCS	B-21478

Routing and Rasping

HM Remover

TMA022

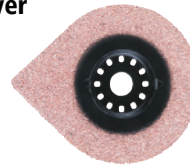

Application/ Recommended Use

Routing joints on wall and floor tiles
Removing mortar or tile adhesive
Removing joints in the smallest of corners with the tungsten carbide tip

	Dia (mm)	Type	Part No.
OIS	70	HM grit #40	B-21484

Diamond Seg Saw Blade

TMA026



Application/ Recommended Use

Cutout of soft wall tiles and FRP
Routing recesses in epoxy/glass fiber reinforced plastic
Routing joints on wall tiles

	Dia (mm)	Type	Part No.
OIS	85	Diamond grit #40	B-21521

Scraping

Scraper 52 Flexible

TMA019



Application/ Recommended Use

Removing soft carpet adhesive residues
Removing paint residues
Removing silicone joints

	Dia (mm)	Type	Part No.
OIS	52 x 45	HCS	B-21456

Riff sanding plate

HM Sanding Plate 78

TMA025

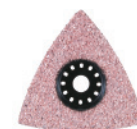
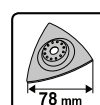

Application/ Recommended Use

Removing mortar or tile adhesive
Removing carpet adhesive residues from a mineral surface

	Dia (mm)	Type	Part No.
OIS	78	HM grit #30	B-21515

Multi tool papers applications

Rating Suitability for application:

AA = Especially Suitable

A = Suitable

n.r = No Rating

		Grit	Product Application and Rating on Each Material	Paint	Varnish	Filler	Roughcast	Wood / Wooden materials	Soft wood	Hard wood	Plywood	Chipboard / MDF	Glass fiber reinforced plastics	Metal	Steel (mild steel / carbon steel)	Stone	Marble	Granite	Glass	Perspex	Imitation marble	Glass fiber reinforced plastics		
Wood Long life	Coarse 60																							
	Medium 100	n.r	n.r	n.r	n.r	AA	AA	AA	AA	AA	A	AA	A	n.r	n.r	n.r	n.r	n.r	n.r	n.r	n.r			
	Fine 180																							
Wood	Coarse 60																							
	Medium 100	n.r	n.r	n.r	n.r	AA	A	AA	AA	AA	A	n.r	n.r	n.r	n.r	n.r	n.r	n.r	n.r	n.r	n.r	n.r	n.r	
	Fine 180																							
Paint	Coarse 60																							
	Medium 100	AA	AA	AA	AA	n.r	n.r	A	n.r	n.r	n.r	A	A	n.r	n.r	n.r	n.r	n.r	n.r	n.r	n.r	n.r	n.r	
	Fine 240																							
Stone	Medium 120																							
	Fine 240																							
	Fine 400	A	AA	n.r	n.r	n.r	n.r	n.r	n.r	n.r	n.r	n.r	n.r	n.r	A	A	A	A	A	A	A	A	A	A
	Very Fine 600																							
	Very Fine 1200																							

BATTERY / CHARGERS

FIXING FASTENING (SCREWDRIVER BITS / IMPACT SOCKETS)

DRILLING (WOOD / METAL / MASONRY)

DRILLING / DEMOLITION [CONCRETE]

CUTTING [METAL]

MULTI TOOL ACCESSORIES

DIAMOND [CUTTING / GRINDING]

GRINDING ACCESSORIES

SANDING / POLISHING ACCESSORIES

SAWING ACCESSORIES

ROUTERS / PLANERS ACCESSORIES

CLEANERS ACCESSORIES

HEAT GUN / LASERS ACCESSORIES

BRAD NAILS/ PINS STAPLER

GARDEN TOOLS ACCESSORIES

HAND TOOLS / COMBINATION SETS

Abrasive delta paper

Wood / long-life

Use with Sanding pad (B-21537) (hook & loop type)

Application/ Recommended Use

Suitable for sanding wood, hardwood, chipboard, construction boards and metal



Paper Size (mm)	Grit	Per Pkg	Part No.
94	60	10	B-21565
94	100	10	B-21587
94	180	10	B-21602

Wood

Application/ Recommended Use

Suitable for sanding wood and wooden materials



Paper Size (mm)	Grit	Per Pkg	Part No.
94	60	10	B-21624
94	100	10	B-22947
94	180	10	B-21652

Paint

Application/ Recommended Use

Suitable for sanding paint, varnish or roughcast



Paper Size (mm)	Grit	Per Pkg	Part No.
94	60	10	B-21680
94	100	10	B-21705
94	240	10	B-21711

BATTERY / CHARGERS

FIXING FASTENING (SCREWDRIVER BITS / IMPACT SOCKETS)

DRILLING (WOOD / METAL / MASONRY)

DRILLING / DEMOLITION [CONCRETE]

CUTTING [METAL]

MULTI TOOL ACCESSORIES

DIAMOND [CUTTING / GRINDING]

GRINDING ACCESSORIES

SANDING / POLISHING ACCESSORIES

SAWING ACCESSORIES

ROUTERS / PLANERS ACCESSORIES

CLEANERS ACCESSORIES

HEAT GUN / LASERS ACCESSORIES

BRAD NAILS/ PINS STAPLER

GARDEN TOOLS ACCESSORIES

HAND TOOLS / COMBINATION SETS

Abrasive delta paper

Stone

Application/ Recommended Use

Suitable for coarse to gloss sanding of extremely hard materials such as stone or glass



Paper Size (mm)	Grit	Per Pkg	Part No.
94	120	10	B-21749
94	240	10	B-21755
94	400	10	B-21761
94	600	10	B-21777
94	1200	10	B-21783

Fleece

Application/ Recommended Use

Suitable for removing the rust of metal and the dirt of wood



Paper Size (mm)	Grit	Per Pkg	Part No.
94	Medium / 280	1	B-21799
94	Coarse / 100	1	B-21808
94	Without Grit	1	B-21814

Polishing felt

Application/ Recommended Use

Suitable for pre-polishing very dirty or scratched surfaces



Paper Size (mm)	Grit	Per Pkg	Part No.
94	Hard	1	B-21820



Diamond

Cutting and Grinding [Concrete]



- BATTERY / CHARGERS
- FIXING FASTENING (SCREWDRIVER BITS / IMPACT SOCKETS)
- DRILLING (WOOD / METAL / MASONRY)
- DRILLING / DEMOLITION (CONCRETE)
- CUTTING (METAL)
- MULTI TOOL ACCESSORIES
- DIAMOND (CUTTING / GRINDING)
- GRINDING ACCESSORIES
- SANDING / POLISHING ACCESSORIES
- SAWING ACCESSORIES
- ROUTERS / PLANERS ACCESSORIES
- CLEANERS ACCESSORIES
- HEAT GUN / LASERS ACCESSORIES
- BRAD NAILS/ PINS STAPLER
- GARDEN TOOLS ACCESSORIES
- HAND TOOLS / COMBINATION SETS

Diamond Wheel Range

The Makita diamond wheel series offers three types of wheel grades to meet user needs

Premium Range: This yields the highest performance in both cutting speed and durability.

Mid Range: This achieves an optimum balance between performance and price.

Standard Range: This has the attraction of a reasonable price tag.

Features of Shape



Segmented Type:

Most commonly used. Blade has slits and a layer of diamond is sintered on the edges. Cuts faster than continuous rim type and maintains average cutting surface



Segmented Wave Type:

This wheel has slits like the segmented wheel. Each segment has many notches (Wave). These notches ensure:

- Fast cutting with less resistance.
- Smooth debris removal.
- Less loading on wheel



Corrugated Type:

This wheel has notches around the Rim. Has a characteristic between Continuous Rim and Segmented Type. Has faster cutting like Segmented Type. At the same time, can attain cleaner surface like continuous rim without broken edges



Continuous Rim Type:

Has layer of diamond with uniform thickness around the entire rim. Can maintain clean surface even on crusty, brittle materials. Cuts with accuracy but not as fast as segment type wheel



Electrodeposited Type:

Diamonds are electrodeposited and has more exposure than bonded type. Cuts faster and more efficient.



Vacuum brazed Type:

Diamonds are vacuum brazed and has more exposure than bonded type. Able to cut harder material. It is longer life than Electrodeposited type because diamonds are held tightly

Materials

⊙ : Specially suitable

○ : Suitable

Material No. 1	Material No. 2	Material No. 3	Material No. 4	Material No. 5	Material No. 6	Material No. 7
Hard concrete 	Concrete 	Marble 	Brick 	Asphalt 	Tile 	Glass
Granite 	Block 	Unglazed Tile 	Aggregate Block 			
Gneiss 	U-shaped Groove 		French Tile 			
Smoothable Engineering 	Sidewalk Block 					
Carbonaceous Shale 	Cemented Tile 					
Sidewalk Slate 						
Engineering Block and Class 2 						

Diamond Wheel Shape

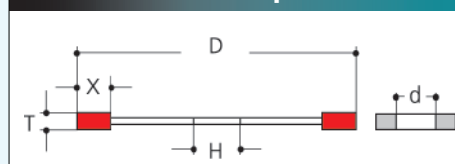

Diamond wheels - Segmented



Standard Range

D	T	X	H	d	Color	For Material							For Model		Part No.	Ideal for
						1	2	3	4	5	6	7				
105	2.0	7	20	16	Gold		⊙	⊙	○	○			100mm Grinder, 110mm Cutter	DRY	D-05197	Concrete
125	2.0	7	22.23	20	Gold		⊙	○	○	○			125mm Grinder, Cutter	DRY	A-88901	
180	2.0	7	25.4	22.23	Gold		⊙	○	○	○			180mm Grinder, Cutter	DRY	A-87909	
115	1.9	7	22.23	-	Gold		⊙	⊙	○	○			115mm Grinder	DRY	A-84109	Concrete
125	1.9	7	22.23	20	Gold		⊙	⊙	○	○			125mm Grinder, Cutter	DRY	A-84115	
150	2.1	7	22.23	-	Gold		⊙	⊙	○	○			150mm Grinder	DRY	B-06432	
180	2.3	7	25.4	22.23	Gold		⊙	⊙	○	○			180mm Grinder, Cutter	DRY	A-84121	
230	2.5	7	22.23	-	Gold		⊙	⊙	○	○			230mm Grinder	DRY	A-84137	Granite
105	1.7	7	20	16	Silver	⊙	⊙	⊙	○	○			100mm Grinder, 110mm Cutter	DRY	A-84090	
115	1.8	7	22.23	-	Silver	⊙	⊙	⊙	○	○			115mm Grinder	DRY	A-84006	
125	2.0	7	22.23	20	Silver	⊙	⊙	⊙	○	○			125mm Grinder, Cutter	DRY	A-84012	
180	2.0	6	25.4	22.23	Silver	⊙	⊙	⊙	○	○			180mm Grinder, Cutter	DRY	A-84028	
230	2.2	6.5	22.23	-	Silver	⊙	⊙	⊙	○	○			230mm Grinder	DRY	A-84408	

Mid Range

D	T	X	H	d	Color	For Material							For Model		Part No.	Ideal for
						1	2	3	4	5	6	7				
125	2	7	22.23	20	Blue		⊙	⊙	○	○			125mm Grinder, Cutter	DRY	A-02808	Concrete
105	1.8	7.5	20	16	Gold		⊙	⊙	○				100mm Grinder, 110mm Cutter	DRY	A-87149	
110	1.8	6	20	-	Gold		⊙	⊙	○	○			110mm Cutter	DRY	A-05022	

Premium Range

D	T	X	H	d	Color	For Material							For Model		Part No.	Ideal for
						1	2	3	4	5	6	7				
125	1.9	7	22.23	20	Blue	⊙	⊙	⊙	⊙				125mm Grinder, 125mm Cutter	DRY	A-01236	Granite
125	2	7.5	22.23	20	Black				⊙	⊙			125mm Grinder, Cutter	DRY	A-02808	Brick
125	2.5	7	25.4	-	Blue	⊙	⊙	⊙	⊙	○			255mm Cutter	DRY	A-02406	Granite

Diamond wheels - Segmented Wave



Standard Range

D	T	X	H	d	Color	For Material							For Model		Part No.	Ideal for
						1	2	3	4	5	6	7				
105	1.8	7.5	20	16	Gold		⊙	⊙	○	○			100mm Grinder, 110mm Cutter	DRY	B-03028	Ideal for Concrete
115	2.0	7.5	22.23	-	Blue		⊙	⊙	○	○			115mm Grinder	DRY	A-80422	
125	2.0	7.5	22.23	-	Blue		⊙	⊙	○	○			125mm Grinder	DRY	A-80438	
180	2.2	7.0	22.23	-	Blue		⊙	⊙	○	○			180mm Grinder	DRY	A-83842	
230	2.5	7.5	22.23	-	Blue		⊙	⊙	○				230mm Grinder	DRY	A-80173	

Premium Range

D	T	X	H	d	Color	For Material								For Model		Part No.	Ideal for	
						1	2	3	4	5	6	7	8					
105	2.0	7.5	20	-	Gold	⊙	⊙	⊙							100mm Cutter	DRY	B-02032	Concrete,
230	2.5	7.5	22.23	-	Gold	⊙	⊙	⊙	○	○					230mm Cutter	DRY	B-02004	Granite

BATTERY / CHARGERS

FIXING FASTENING (SCREWDRIVER BITS / IMPACT SOCKETS)

DRILLING (WOOD / METAL / MASONRY)

DRILLING / DEMOLITION [CONCRETE]

CUTTING [METAL]

MULTI TOOL ACCESSORIES

DIAMOND [CUTTING / GRINDING]

GRINDING ACCESSORIES

SANDING / POLISHING ACCESSORIES

SAWING ACCESSORIES

ROUTERS / PLANERS ACCESSORIES

CLEANERS ACCESSORIES

HEAT GUN / LASERS ACCESSORIES

BRAD NAILS / PINS STAPLER

GARDEN TOOLS ACCESSORIES

HAND TOOLS / COMBINATION SETS

BATTERY / CHARGERS

FIXING FASTENING (SCREWDRIVER BITS / IMPACT SOCKETS)

DRILLING (WOOD / METAL / MASONRY)

DRILLING / DEMOLITION (CONCRETE)

CUTTING (METAL)

MULTI TOOL ACCESSORIES

DIAMOND (CUTTING / GRINDING)

GRINDING ACCESSORIES

SANDING / POLISHING ACCESSORIES

SAWING ACCESSORIES

ROUTERS / PLANERS ACCESSORIES

CLEANERS ACCESSORIES

HEAT GUN / LASERS ACCESSORIES

BRAD NAILS/ PINS STAPLER

GARDEN TOOLS ACCESSORIES

HAND TOOLS / COMBINATION SETS

Diamond wheels - Corrugated

Standard Range

D	T	X	H	d	Color	For Material								For Model		Part No.	Ideal for	
						1	2	3	4	5	6	7	8					
105	2.0	7	20	16	Gold	⊙	⊙	○							100mm Grinder, 110mm Cutter	DRY	D-05206	Concrete
115	2.0	7	22.23	-	Gold	⊙	⊙	○	○						115mm Grinder	DRY	A-84143	
125	2.1	7	22.23	20	Gold	⊙	⊙	○	○						125mm Grinder, Cutter	DRY	A-84159	
180	2.3	7	25.4	22.23	Gold	⊙	⊙	○	○						180mm Grinder, Cutter	DRY	A-84165	
230	2.6	7	22.23	-	Gold	⊙	⊙	○	○						230mm Grinder	DRY	A-84171	Granite
105	2.0	7	20	16	Silver	⊙	⊙	⊙	○	○					100mm Grinder, 110mm Cutter	DRY	A-84040	
230	2.6	7	22.23	-	Silver	⊙	⊙	⊙	○	○					230mm Grinder	DRY	A-84084	
110	1.6	5	20	-	Gold	⊙	⊙	⊙	○	○	⊙				110mm Cutter	WET	B-02836	-
115	2.0	7	22.23	-	Silver		⊙	⊙	⊙	○					115mm Grinder	DRY	B-02967	Soft Material
115	2.0	7	22.33	-	Gold		⊙	⊙							115mm Grinder	DRY	A-88939	
180	2.0	7	25.4	22.3	Gold		⊙	⊙							180mm Grinder, Cutter	DRY	A-88951	
180	2.0	7	25.4	22.23	Gold		⊙	⊙							180mm Grinder	DRY	A-86804	
230	2.3	7	22.23		Silver		⊙	⊙	⊙	○					230mm Grinder	DRY	B-01806	
230	2.3	7	22.23	-	Gold		⊙	⊙							230mm Grinder	DRY	A-88967	

Mid Range

D	T	X	H	d	Color	For Material								For Model		Part No.	Ideal for	
						1	2	3	4	5	6	7	8					
125	2.0	7	22.23	-	Blue	⊙	⊙	⊙	○	○					125mm Grinder	DRY	A-80690	Ceramic Tile
180	2.0	7	22.23	A	Blue	⊙	⊙	⊙	○	○					180mm Grinder	DRY	A-80709	
110	1.5	6	20	-	Gold	⊙	⊙	⊙	⊙						110mm Cutter	WET	A-07238	-

Premium Range

D	T	X	H	d	Color	For Material								For Model		Part No.	Ideal for	
						1	2	3	4	5	6	7	8					
105	2.2	7	22.23	20	Blue	⊙	⊙	⊙							110mm Cutter	DRY	A-02347	For Ceramic Tile
110	1.2	6	20	-	Blue			⊙	○	○	⊙	⊙			110mm Cutter	WET	B-00795	For Bullet Proof Glass
125	2	7	22.23	20	Blue	⊙	⊙	⊙	○	○					125mm Grinder, Cutter	DRY	A-02761	For Ceramic Tile

Diamond Wheels for Cutters - Continuous Rim

Standard Range

D	T	X	H	d	Color	For Material								For Model		Part No.	
						1	2	3	4	5	6	7	8				
105	1.6	5	20	16	Gold								⊙		110mm Grinder / Cutter	DRY	A-89012
110	1.6	5	20	-	Gold		⊙	⊙	○				○		110mm Cutter	WET	D-05212
115	1.6	5	22.23	-	Gold				○				⊙		115mm Grinder	WET	A-89028
180	1.85	4	25	-	Gold	○	⊙	⊙	○	○	⊙				180mm Cutter	WET	A-80117

Mid Range

D	T	X	H	d	Color	For Material								For Model		Part No.	
						1	2	3	4	5	6	7	8				
110	1.5	4	20	-	Silver	⊙	⊙	⊙		⊙					110mm Cutter	WET	A-90598
180	1.85	4	25	-	Blue	⊙	⊙	⊙	⊙	⊙					180mm Cutter	WET	B-01220
110	1.5	4	20	-	Gold	○	⊙	⊙	○	○	⊙				110mm Cutter	WET	A-81131
180	1.85	4	25.4	-	Gold	○	⊙	⊙	○	○	⊙				180mm Cutter	WET	A-87161

Diamond Blade For Cordless Cutters

Type A: High Grade / Continuous rim / Wet

B: Standard / Continuous rim / Glass / Wet

D: Standard / Electrodeposited / Glass & Porcelain / Wet

D	T	X	H	d	Color	For Material								For Model	Type	Part No.
						1	2	3	4	5	6	7	8			
80	0.8	3	15	-	Silver									CC301D	A	792296-4
85	0.9	4	15	-	Silver			○	○			○		CC301D	B	A-01323
85	0.8	2.2	15	-	Silver			○				○	○	CC301D	D	A-07179

BATTERY / CHARGERS

FIXING FASTENING (SCREWDRIVER BITS / IMPACT SOCKETS)

DRILLING (WOOD / METAL/ MASONRY)

DRILLING / DEMOLITION [CONCRETE]

CUTTING [METAL]

MULTI TOOL ACCESSORIES

DIAMOND [CUTTING / GRINDING]

GRINDING ACCESSORIES

SANDING / POLISHING ACCESSORIES

SAWING ACCESSORIES

ROUTERS / PLANERS ACCESSORIES

CLEANERS ACCESSORIES

HEAT GUN / LASERS ACCESSORIES

BRAD NAILS/ PINS STAPLER

GARDEN TOOLS ACCESSORIES

HAND TOOLS / COMBINATION SETS

Diamond Wheel - Electro Deposited

Standard Range

Best in cutting softer materials such as Resin board, Fiberglass, pipe etc

- The protruding grit volume allows for easier cutting of marble, sand stone and limestone.
- There is no heat generated therefore the cutting of material is quicker and easier.
- Have a high grit density which gives a higher accuracy when cutting.

Segemented Type

D	T	X	H	d	Color	For Material	For Model	Type	Part No.
115	2	5	22.23	-	Silver	Marble, sand stone and limestone	115mm Grinder	DRY	D-51085
180	2.2	5	22.23	-	Silver	Marble, sand stone and limestone	180mm Grinder	DRY	D-51091



Diamond Wheel for Porcelain Tile

- HIGH SPEED AND GREAT PRECISION
- LESS TILE CHIPPING



Helps in heat radiation

Widely used in all construction sites when laying tiles on floors and walls

(used with 115mm Angle Grinders)



Segemented Type

D	T	X	H	d	Color	For Material	For Model	Type	Part No.
115	1.4	-	22.23	-	Purple	Porcelain Tile	115mm Grinder	DRY	D-65109

- BATTERY / CHARGERS
- FIXING FASTENING (SCREWDRIVER BITS / IMPACT SOCKETS)
- DRILLING (WOOD / METAL/ MASONRY)
- DRILLING / DEMOLITION (CONCRETE)
- CUTTING [METAL]
- MULTI TOOL ACCESSORIES
- DIAMOND [CUTTING / GRINDING]
- GRINDING ACCESSORIES
- SANDING / POLISHING ACCESSORIES
- SAWING ACCESSORIES
- ROUTERS / PLANERS ACCESSORIES
- CLEANERS ACCESSORIES
- HEAT GUN / LASERS ACCESSORIES
- BRAD NAILS/ PINS STAPLER
- GARDEN TOOLS ACCESSORIES
- HAND TOOLS / COMBINATION SETS

Diamond Blade For X-Lock Grinders

- High Durability
- High Quality
- Segmented Rim
- Suitable for Cordless X-lock Grinders Grinders (Also compatible with conventional angle grinders)
- Ideal for Concrete, Granite, Marble



X-Lock fitting just one click to attach the accessories and easy removal just simply pull the lever



D	T	X	H	d	Color	For Material	For Model	Part No.
125				22.23	Green	Concrete, Granite, Marble	DGA519	E-02076
115				22.23	Green		DGA469	E-02060

Rescue Force Diamond Wheel For Power Cutter

Every second counts when passengers have to be rescued from aeroplanes and trains. Now at last there is an efficient, tried and tested cutting disc that can cut open aeroplanes and high-speed trains and cut through crash barriers.

- The Diamond Rescue Force cutting disc cuts through all materials.
- It cuts effortlessly through alloys, steel, safety glass, concrete, carbon-fibre reinforced plastic and armoured glass.
- The Rescue Force rescue disc has much bigger diamonds than traditional cutting discs.
- Rescue Force cuts to a depth of up to 125mm. It is fast and reliable where other cutting discs fail.



D	T	X	H	d	Color	Materials	For Model	Part No.
350	3.0	-	25.4	-	Gold	Light metal, Concrete	355mm Power Cutter	966544060

Specialized / Vacuum brazed Rescue Diamond Wheel For Power Cutter / Grinders

- These diamond blades are used for rescue operation and can cuts various materials.
- Vacuum brazed diamond wheels are high durable and long-lasting.
- Extremely suitable for demolition work.



D	T	X	H	d	Color	For Material								For Model	Part No.	
						1	2	3	4	5	6	7	8			
230	3.1	4	22.23	-	RED	⊙	⊙	⊙	⊙	⊙				230mm Grinder & Power Cutter	WET	B-55326

Diamond Blade For Cordless Power Cutter

- High Durability and High Quality diamond wheel with even pattern placement of diamond grits
- The grit arrangement provides sharp cutting edge constantly.
- Specifically developed for the DCE090 cordless cutter.
- Ideal for stone, concrete.
- Segmented.
- Wet & Dry



D	T	X	H	d	Color	For Material								For Model	Part No.
						1	2	3	4	5	6	7	8		
230	3.2	13		22.23	Green	⊙	⊙							DCE090	E-02967

Diamond Wheels For Power Cutter / Angle Cutter

A: Standard / Segmented / General B: Standard / Segmented / Concrete, Brick
 C: Standard / Segmented / Concrete & Asphalt / Dry D: Standard / Segmented / Asphalt

D	T	X	H	d	Color	Materials						For Model	Part No.	
						1	2	3	4	5	6			
300	2.8	5	25.4	20	Silver	⊙	⊙	⊙	⊙			305mm Power Cutter	A	A-86773
305	2.8	6.5	25.4	20	Silver	⊙	⊙	⊙	⊙			305mm Power Cutter	B	A-89349
305	3.0	7.5	30	*	Blue		⊙	⊙	⊙	⊙		305mm Power Cutter/ Angle Cutter	C	A-02490
350	3.2	5	25.4	20	Silver	⊙	⊙	⊙	⊙			355mm Power Cutter	A	A-87317
350	2.88	6	25.4	-	White	Asphalt						355mm Power Cutter	D	966244011
350	3.0	-	25.4	-	Green	Long life in abrasive materials						355mm Power Cutter	B	966244030

* 20,22,23,25.4 (Ring size)

Diamond Wheels For Power Cutter - COSMOS Series

Premium universal application 3D Grid diamond blade

- Available with Stealth technology giving ultimate vibration and noise dampening for the best feel or with a reinforced centre and cooling holes for a fast and comfortable cut. Laser welded, wet and dry use.



D	T	X	H	d	Color	Materials								For Model	Part No.
						1	2	3	4	5	6	7	8		
400	3.0	12	25.4	20	Red	⊙	⊙	⊙	⊙	⊙			405 mm Power Cutter	B-13471	

Diamond Wheels For Power Cutter - The Dia-duran (Long Last runners)

DiaDuran blades have an enormous cutting capacity and thanks to a patented micro-fusion process have a much longer lifetime than diamond blades manufactured with conventional sintering techniques

A: Standard / Segmented / Concrete, Brick B: High Grade / Segmented / Asphalt

D	T	X	H	d	Color	For Material	For Model	Part No.
350	3.3	7	25.4	-	Silver	Concrete Stone	355mm Power Cutter	A 966344020
350	3.0	6.5	25.4	-	Silver	Asphalt	355mm Power Cutter	B 966344010

BATTERY / CHARGERS

FIXING FASTENING (SCREWDRIVER BITS / IMPACT SOCKETS)

DRILLING (WOOD / METAL/ MASONRY)

DRILLING / DEMOLITION [CONCRETE]

CUTTING [METAL]

MULTI TOOL ACCESSORIES

DIAMOND [CUTTING / GRINDING]

GRINDING ACCESSORIES

SANDING / POLISHING ACCESSORIES

SAWING ACCESSORIES

ROUTERS / PLANERS ACCESSORIES

CLEANERS ACCESSORIES

HEAT GUN / LASERS ACCESSORIES

BRAD NAILS/ PINS STAPLER

GARDEN TOOLS ACCESSORIES

HAND TOOLS / COMBINATION SETS

- BATTERY / CHARGERS
- FIXING FASTENING (SCREWDRIVER BITS / IMPACT SOCKETS)
- DRILLING (WOOD / METAL / MASONRY)
- DRILLING / DEMOLITION [CONCRETE]
- CUTTING [METAL]
- MULTI TOOL ACCESSORIES
- DIAMOND [CUTTING / GRINDING]
- GRINDING ACCESSORIES
- SANDING / POLISHING ACCESSORIES
- SAWING ACCESSORIES
- ROUTERS / PLANERS ACCESSORIES
- CLEANERS ACCESSORIES
- HEAT GUN / LASERS ACCESSORIES
- BRAD NAILS/ PINS STAPLER
- GARDEN TOOLS ACCESSORIES
- HAND TOOLS / COMBINATION SETS

Diamond Blade For Wall Chaser



A: Segmented / Dry

D	T	X	H	d	Color	For Material								For Model		Part No.
						1	2	3	4	5	6	7	8			
150	2.4	7	22.23	-	Black	⊙	⊙	⊙	⊙					SG150	A	P-22311
125	2	7.5	22.23	-	Blue	⊙	⊙	○	○					SG1251J	A	A-80438

PCD Offset Diamond Wheel

This offset diamond wheel can be used for removing polyurethane, adhesive, paint, epoxy and acrylic coatings.



< Difference with the normal offset diamond >



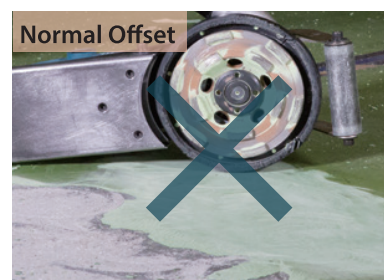

PCD Offset

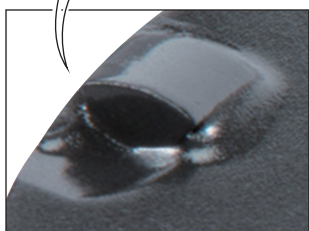

Normal Offset

It just scratched the surface and couldn't remove the paint film.



	Application	D	T	X	H	d	Color	1	2	3	4	5	For Model	Part No.
	For removal of polyurethane, adhesive, paint, epoxy and acrylic coatings	125	-	-	22.23	-	Black	-	-	-	-	-	PC5000C/5001C or 125mm Grinders (with SJS or Soft start system)	B-53160
		180	-	-	22.23	-	Black	-	-	-	-	-	180mm Grinders (with SJS or Soft start system)	B-53176

Offset diamond wheel for Grinders / Concrete Planers

	Application	D	T	X	H	d	Color	For Material					For Model	Part No.
								1	2	3	4	5		
	Standard Work - For concrete - Double type	100	8	5	22.23	16	Silver	⊙	⊙	⊙	○	○	115mm, 125mm Grinders	D-62309
	Fine Work - For general use - Turbo Tye	105	10	5	22.23	-	Gold	○	⊙	○	○	○	115mm, 125mm Grinders	B-44993
	Rough Work - For coarse grinding work - Single Type	105	4	8	22.23	-	Silver	○	⊙	○	○	○	115mm, 125mm Grinders	B-14629
	Fine Work - For general use - Turbo Tye	110	13.5	4	15	-	Blue	⊙	⊙	⊙	○	○	PC1100	A-07369
	Standard Work - For coarse grinding work - For removing point - Segmeted Type	110	8	5	15	-	Silver	⊙	⊙	⊙	○	○	PC1100	A-86321
	Fine Work - For fine finishing - Rim type	125	13.5	4	22.23	-	Gold	⊙	⊙	⊙	○	○	PC5000, PC5001C 125mm Grinder	B-12289
	Standard Work - For coarse grinding work - For removing point - Double Type	125	8	5	22.23	-	Gold	⊙	⊙	⊙	○	○	PC5000, PC5001C	B-12295

BATTERY / CHARGERS

FIXING FASTENING (SCREWDRIVER BITS / IMPACT SOCKETS)

DRILLING (WOOD / METAL/ MASONRY)

DRILLING / DEMOLITION [CONCRETE]

CUTTING [METAL]

MULTI TOOL ACCESSORIES

DIAMOND [CUTTING / GRINDING]

GRINDING ACCESSORIES

SANDING / POLISHING ACCESSORIES

SAWING ACCESSORIES

ROUTERS / PLANERS ACCESSORIES

CLEANERS ACCESSORIES

HEAT GUN / LASERS ACCESSORIES

BRAD NAILS/ PINS STAPLER

GARDEN TOOLS ACCESSORIES

HAND TOOLS / COMBINATION SETS

Ring
(10 pc/ set)



Type	(H)Outer Dia	(D)Hole Dia	Part No.
Ring 20	22.23mm	20mm	A-85248

- BATTERY / CHARGERS
- FIXING FASTENING (SCREWDRIVER BITS / IMPACT SOCKETS)
- DRILLING (WOOD / METAL / MASONRY)
- DRILLING / DEMOLITION [CONCRETE]
- CUTTING [METAL]
- MULTI TOOL ACCESSORIES
- DIAMOND [CUTTING / GRINDING]
- GRINDING ACCESSORIES
- SANDING / POLISHING ACCESSORIES
- SAWING ACCESSORIES
- ROUTERS / PLANERS ACCESSORIES
- CLEANERS ACCESSORIES
- HEAT GUN / LASERS ACCESSORIES
- BRAD NAILS/ PINS STAPLER
- GARDEN TOOLS ACCESSORIES
- HAND TOOLS / COMBINATION SETS

Vacuum Brazed Diamond Core Bit For Grinders

- Used with high speed angle grinders.
- Suitable for quick drilling.
- Material : Granite/Marble/Porcelain Tile



Available in different shapes and sizes



Dia	Spindle Thread	Type	Material	Part no
5mm				D-61064
6mm				D-61070
8mm				D-61086
10mm				D-61092
12mm				D-61101
14mm				D-44432
16mm				D-44448
20mm	M14	Dry	For Granite / Marble / Tile	D-44454
22mm				D-44460
25mm				D-44476
27mm				D-44482
30mm				D-44498
32mm				D-44507
35mm				D-44513
38mm				D-44529
40mm				D-44535

Grinding Accessories

Abrasive wheels / Flap Disc / Wire Brush / Burrs
Other Grinder Accessories



- BATTERY / CHARGERS
- FIXING FASTENING (SCREWDRIVER BITS / IMPACT SOCKETS)
- DRILLING (WOOD / METAL/ MASONRY)
- DRILLING / DEMOLITION [CONCRETE]
- CUTTING [METAL]
- MULTI TOOL ACCESSORIES
- DIAMOND [CUTTING / GRINDING]
- GRINDING ACCESSORIES
- SANDING / POLISHING ACCESSORIES
- SAWING ACCESSORIES
- ROUTERS / PLANERS ACCESSORIES
- CLEANERS ACCESSORIES
- HEAT GUN / LASERS ACCESSORIES
- BRAD NAILS/ PINS STAPLER
- GARDEN TOOLS ACCESSORIES
- HAND TOOLS / COMBINATION SETS

Abrasive Wheel

Part number: B-12201-12
 Size: 100x16mm
 Max operating speed: max: 80m/s (4800 m/min), max: 15300min⁻¹ (15300rpm)

Validity Spec

Pictograms for safety use

Application: Color code

- Blue: Metal
- Gold: INOX / Stainless Steel
- Green: Masonry
- Silver: Aluminium

How to read the spec



Aluminum Oxide Group

Brown Fused Aluminum : A



Black Silicon Carbide : C



White Aluminum Oxide : WA



Alumina Zirconium : Z



Grit Size

24 36 60 80 120

Coarse

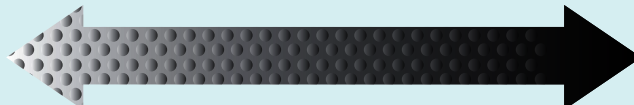

Fine



Hardness of grinding wheel

Closer to A, softer grinding wheel is
 Closer to Z, harder grinding wheel is

Soft grinding wheel

Hard grinding wheel ▶ Hard work piece
 ▶ Soft work piece

Very Soft	Soft	Middle	Hard	Very Hard
A - G	H - K	L - O	P - S	T - Z



Type of Bond

Resin Bonded = Resinoid(BF)

Main component is phenol resin
 Mechanically strong, but weak against moisture and high heat

X-LOCK ACCESSORIES

Easy installing and removing the accessories in one step
Improve your work efficiency and work environment!



- Abrasive Grinding and Thin Cutting wheel for X-Lock Grinders
- No burn mark and bur
- Less Vibration

**1.2mm
Thickness**
(for thin
cutting wheels)

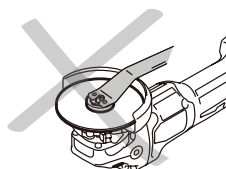

X-LOCK mechanism ensures that the accessory is properly mounted to the tool without a nut, flange or spanner and cannot be mounted incorrectly. 115mm and 125mm X-lock wheels are also compatible with conventional angle grinders

X-LOCK Thin Cutting Wheels

Size (mm)	Grit		Pc / pkg	Part No.
115×1.2×22.23	A60T Inox - Mild Steel	13,300	1	E-00387
125×1.2×22.23	A60T Inox - Mild Steel	12,250	1	E-00418

X-LOCK Depressed Center Grinding Wheels

Size (mm)	Grit		Pc / pkg	Part No.
115×6.0×22.23	A36P - Metal	13,300	1	E-00365
125×6.0×22.23	A36P - Metal	12,250	1	E-00393

BATTERY /
CHARGERS

FIXING FASTENING
(SCREWDRIVER BITS
/ IMPACT SOCKETS)

DRILLING
(WOOD / METAL/
MASONRY)

DRILLING
/ DEMOLITION
[CONCRETE]

CUTTING
[METAL]

MULTI TOOL
ACCESSORIES

DIAMOND
[CUTTING / GRINDING]

GRINDING
ACCESSORIES

SANDING
/ POLISHING
ACCESSORIES

SAWING
ACCESSORIES

ROUTERS
/ PLANERS
ACCESSORIES

CLEANERS
ACCESSORIES

HEAT GUN / LASERS
ACCESSORIES

BRAD NAILS/ PINS
STAPLER

GARDEN TOOLS
ACCESSORIES

HAND TOOLS /
COMBINATION SETS

- BATTERY / CHARGERS
- FIXING FASTENING (SCREWDRIVER BITS / IMPACT SOCKETS)
- DRILLING (WOOD / METAL/ MASONRY)
- DRILLING / DEMOLITION [CONCRETE]
- CUTTING [METAL]
- MULTI TOOL ACCESSORIES
- DIAMOND [CUTTING / GRINDING]
- GRINDING ACCESSORIES
- SANDING / POLISHING ACCESSORIES
- SAWING ACCESSORIES
- ROUTERS / PLANERS ACCESSORIES
- CLEANERS ACCESSORIES
- HEAT GUN / LASERS ACCESSORIES
- BRAD NAILS/ PINS STAPLER
- GARDEN TOOLS ACCESSORIES
- HAND TOOLS / COMBINATION SETS

Thin Cutting Wheels - Flat Center (B-series)

Application/ Recommended Use

- Fast cutting.
- No burn mark and burr.
- Can cut steel, stainless steel, aluminium & copper.

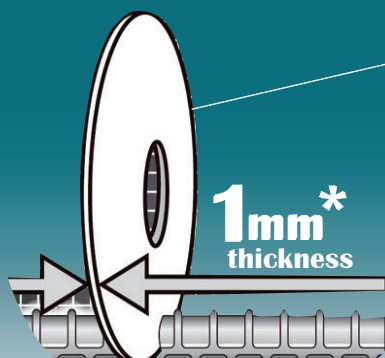

- * 1.6mm thickness for 150/180mm wheel
- * 1.9mm thickness for 230mm wheel



Size (mm)	Grit	Package Details	Max. RPM	Part No.	
100 x 1.0 x 16mm	Inox A60T	10pcs Shrink Wrapped wheels	4sets = 40pcs per box	15,300	B-12201
115x1.0x22.23mm	Inox A60T		5sets = 50pcs per box	13,300	B-12217
125x1.0x22.23mm	Inox A60T		5sets = 50pcs per box	12,250	B-12239
150x1.6x22.23mm	Inox A60T		4sets = 40pcs per box	10,200	B-12251
180x1.6x22.23mm	Inox A60T		4sets = 40pcs per box	8,300	B-12267
230x1.9x22.23mm	Inox A60T		4sets = 40pcs per box	6,650	B-12273



Thin Cut-off Wheels for Stainless Steel - Flat Center (D-series)

Application/ Recommended Use

- Higher cutting speeds, up to 2-3 times faster than 3mm thin wheels.
- Reduced wastage of work materials.
- No discoloration (rust) around stainless steel cutting edge.



Size (mm)	Grit	Max. RPM	Part No.
100 x 1.0 x 16	WA60T	15,280	D-18758
115 x 1.2 x 22.23	WA60T	13,290	D-18764
125 x 1.2 x 22.23	WA60T	12,200	D-18770
180 x 2.0 x 22.23	WA36R	8,600	D-18786
230 x 2.0 x 22.23	WA36R	6,600	D-18792

Depressed Center Cutting Wheel (D-series)

A30S : For Metal



Size (mm)	Grit	Max. RPM	Part No.
100 x 3.0 x 16.00	A30S	15,280	D-18552
115 x 3.0 x 22.23		13,290	D-18568
125 x 3.0 x 22.23		12,200	D-18574
180 x 3.0 x 22.23		8,600	D-18580
230 x 3.0 x 22.23		6,600	D-18596

Depressed Center Cutting Wheel (A/B-series)

A30T : For Metal

- For fast, clean cuts, notching and slotting



Size (mm)	Grit	Max. RPM	Part No.
100 x 3.0 x 16.00	A30T	13,690	A-83587
115 x 3.0 x 22.23		13,290	A-83593
125 x 3.0 x 22.23		12,250	A-83602
150 x 3.0 x 22.23		10,190	B-05050
180 x 3.0 x 22.23		8,500	A-83618
230 x 3.0 x 22.23		6,650	B-62913

Depressed Center Grinding Wheel (D-series)

A24R: For Metal



Size (mm)	Grit	Max. RPM	Part No.
100 x 6.0 x 16.00	A24R	15,280	D-41523
115 x 6.0 x 22.23		13,290	D-41539
125 x 6.0 x 22.23		12,200	D-18465

BATTERY /
CHARGERS

FIXING FASTENING
(SCREWDRIVER BITS
/ IMPACT SOCKETS)

DRILLING
(WOOD / METAL/
MASONRY)

DRILLING
/ DEMOLITION
[CONCRETE]

CUTTING
[METAL]

MULTI TOOL
ACCESSORIES

DIAMOND
[CUTTING / GRINDING]

GRINDING
ACCESSORIES

SANDING
/ POLISHING
ACCESSORIES

SAWING
ACCESSORIES

ROUTERS
/ PLANERS
ACCESSORIES

CLEANERS
ACCESSORIES

HEAT GUN / LASERS
ACCESSORIES

BRAD NAILS/ PINS
STAPLER

GARDEN TOOLS
ACCESSORIES

HAND TOOLS /
COMBINATION SETS

BATTERY
/ CHARGERSFIXING FASTENING
(SCREWDRIVER BITS
/ IMPACT SOCKETS)DRILLING
(WOOD / METAL/
MASONRY)DRILLING
/ DEMOLITION
(CONCRETE)CUTTING
(METAL)MULTI TOOL
ACCESSORIESDIAMOND
(CUTTING / GRINDING)GRINDING
ACCESSORIESSANDING
/ POLISHING
ACCESSORIESSAWING
ACCESSORIESROUTERS
/ PLANERS
ACCESSORIESCLEANERS
ACCESSORIESHEAT GUN / LASERS
ACCESSORIESBRAD NAILS/ PINS
STAPLERGARDEN TOOLS
ACCESSORIESHAND TOOLS /
COMBINATION SETS

Depressed Center Grinding Wheel (A-series)

A36P : For metal

WA36N / WA36O : For stainless steel

- For metal polishing and general flat grinding



Size (mm)	Grit	Max. RPM	Part No.
100 x 6.0 x 16.00	WA36N	13,690	A-80852
115 x 6.0 x 22.23	WA36N	13,300	A-80640
125 x 6.0 x 22.23	WA36N	12,250	A-80656
180 x 6.0 x 22.23	WA36O	8,500	A-80880
230 x 6.0 x 22.23	WA36N	6,600	A-80896
100 x 6.0 x 16.00	A36P	13,690	A-80911
115 x 6.0 x 22.23	A36P	13,290	A-80927
125 x 6.0 x 22.23	A36P	12,250	A-80933
150 x 6.0 x 22.23	A36P	10,190	A-84981
180 x 6.0 x 22.23	A36P	8,500	A-80949
230 x 6.0 x 22.23	A36P	6,650	A-80955

Abrasive cut-off wheel (for Portable Cut-off)

- 3mm thickness
- For all ferrous materials - Steel, Cast iron and other hard metals



Size (mm)	Grit	Type	Pc Per Pkg	Max. RPM	Part No.
305 x 3.0 x 25.4	A36P	Smooth	25	4,500	A-87650-25
355 x 3.0 x 25.4	A36P	Smooth	25	3,900	A-87672-25
405 x 3.0 x 25.4	A36P	Smooth	25	3,380	A-87694-25

Abrasive cut-off wheel (For power cutter)

- Always ensure the max RPM of the wheel matches the power cutter



Size (mm)	Grit	Max. RPM	Part No.
230 x 2.0 x 22.23	Metal	6600 min ⁻¹	D-18792
300 x 3.5 x 20 mm	Metal	5100 min ⁻¹	B-70792
350 x 4.0 x 25.4 mm	Metal	5500 min ⁻¹	B-70839
350 x 4.0 x 25.4 mm	Stone	5500 min ⁻¹	B-70823

Flap Disc



- BATTERY / CHARGERS
- FIXING FASTENING (SCREWDRIVER BITS / IMPACT SOCKETS)
- DRILLING (WOOD / METAL/ MASONRY)
- DRILLING / DEMOLITION [CONCRETE]
- CUTTING [METAL]
- MULTI TOOL ACCESSORIES
- DIAMOND [CUTTING / GRINDING]
- GRINDING ACCESSORIES
- SANDING / POLISHING ACCESSORIES
- SAWING ACCESSORIES
- ROUTERS / PLANERS ACCESSORIES
- CLEANERS ACCESSORIES
- HEAT GUN / LASERS ACCESSORIES
- BRAD NAILS/ PINS STAPLER
- GARDEN TOOLS ACCESSORIES
- HAND TOOLS / COMBINATION SETS

Backing Type

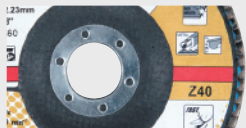

Fiber glass backing
Standard backing type



Nylon backing
For heavy duty

Shape Type





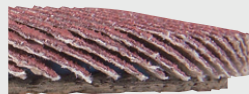









Flat
Effective for flat surface



Angled
Effective for angles or corners

Material Chart

AA : Recommended A : Acceptable

Description of Grit Material	 Aluminum oxide	 Zirconia aluminum	 Silicon carbide
	Best for metal	Best for INOX and metal	Best for Masonry
Description of label color			
Wood 	A		
Plastic 	A		
Metal 	AA	AA	
No ferrous 	A	A	
INOX 		AA	
Masonry 			AA

Flap Disc Series



Material - Zirconia Aluminium:

For sanding and grinding metals and stainless steel. Sands flat, contoured or curved surfaces like a sanding disc.



For Applications

BEST



OPTIONAL



Grit	Dia. (mm)	Grain	Application	Backing type	Backing Shape	Part No. P-Series	Part No. D-Series								
Z 36	115 (4-1/2")	Zircon	Stainless Steel	Fiber Glass	Angled	-	D-27420								
Z 40						-	D-27436								
Z 60						-	D-27442								
Z 80						-	D-27458								
Z 120	-					D-27464									
Z 36	125 (5")					Zircon	Stainless Steel	Fiber Glass	Angled	-	D-27470				
Z 40										P-39104	D-27486				
Z 60										P-39110	D-27492				
Z 80										P-39126	D-27501				
Z 120	-									P-39132	D-27517				
Z 40	150 (6")									Zircon	Stainless Steel	Fiber Glass	Angled	P-39148	-
Z 60														P-39154	-
Z 80		P-39160	-												
Z 120		P-39176	-												
Z 36	180 (7")	Zircon	Stainless Steel	Fiber Glass	Angled									-	D-27523
Z 40														P-39182	D-27539
Z 60														P-39198	D-27545
Z 80						P-39207	D-27551								
Z 120	-					-	D-27567								
Z 40	170					Zircon	Stainless Steel	Fiber Glass	Angled					P-39263	-
Z 60														P-39279	-
Z 80														P-39285	-
Z 120										P-39291	-				

Material-Silicon Carbide: Effective for sanding brick, stone & concrete.



For Applications

BEST



Grit	Dia. (mm)	Grain	Application	Backing type	Backing Shape	Part No								
C 36	115 (4-1/2")	Silicon Carbide	Stone	Fiber Glass	Flat	D-28020								
C 40						D-28036								
C 60						D-28042								
C 80						D-28058								
C 120						D-28064								
C 36	125 (5")					Silicon Carbide	Stone	Fiber Glass	Flat	D-28070				
C 40										D-28086				
C 60										D-28092				
C 80										D-28101				
C 120	D-28117													
C 120	170									Silicon Carbide	Stone	Fiber Glass	Flat	P-39350
C 36	D-28123													
C 40	D-28139													
C 60	D-28145													
C 80	D-28151													
C 120	D-28167													

Material-Aluminium Oxide: For sanding metal, plastic, wood & steel.



For Applications

BEST



OPTIONAL



Grit	Dia. (mm)	Grain	Application	Backing type	Backing Shape	Part No								
A 36	115 (4-1/2")	Aluminium Oxide	Steel	Fiber Glass	Angled	D-27028								
A 40						D-27034								
A 60						D-27040								
A 80						D-27056								
A 120	D-27062													
A 36	125 (5")					Aluminium Oxide	Steel	Fiber Glass	Angled	D-27078				
A 40										D-27084				
A 60										D-27090				
A 80										D-27109				
A 120	D-27115													
A 36	180 (7")									Aluminium Oxide	Steel	Fiber Glass	Angled	D-27121
A 40														D-27137
A 60		D-27143												
A 80		D-27159												
A 120	D-27165													

• Discontinued (Available till the stock last)

Industrial Flap Disc for Heavy Duty



Feature

- High efficiency
- Long life
- Suitable for industrial work site such as dockyard, metal working place and other heavy duty applications
- High-speed Grinding with high-power grinder.
- Remove the rust and burrs.

Efficiency

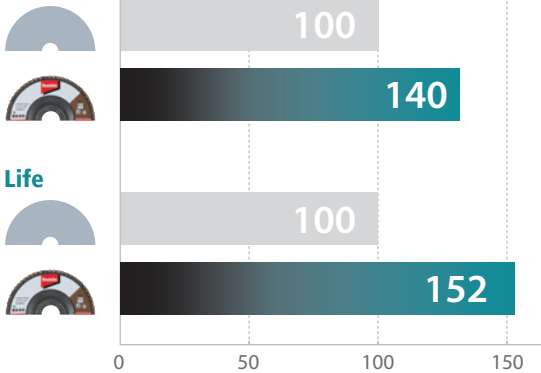

Material - Zirconia Aluminium:

For sanding and grinding metals and stainless steel. Sands flat, contoured or curved surfaces like a sanding disc.

High efficiency & Long life.
Suitable for Industry use.



For Applications



Grit	Dia. (mm)	Grain	Application	Backing type	Backing Shape	Part No. B-Series
Z 40	115 (4-1/2")			Fiber Glass	Angled	B-55603
Z 60						B-55619
Z 80						B-55625
Z 120						B-55631

BATTERY / CHARGERS

FIXING FASTENING (SCREWDRIVER BITS / IMPACT SOCKETS)

DRILLING (WOOD / METAL/ MASONRY)

DRILLING / DEMOLITION [CONCRETE]

CUTTING [METAL]

MULTI TOOL ACCESSORIES

DIAMOND [CUTTING / GRINDING]

GRINDING ACCESSORIES

SANDING / POLISHING ACCESSORIES

SAWING ACCESSORIES

ROUTERS / PLANERS ACCESSORIES

CLEANERS ACCESSORIES

HEAT GUN / LASERS ACCESSORIES

BRAD NAILS/ PINS STAPLER

GARDEN TOOLS ACCESSORIES

HAND TOOLS / COMBINATION SETS

- BATTERY / CHARGERS
- FIXING FASTENING (SCREWDRIVER BITS / IMPACT SOCKETS)
- DRILLING (WOOD / METAL/ MASONRY)
- DRILLING / DEMOLITION [CONCRETE]
- CUTTING [METAL]
- MULTI TOOL ACCESSORIES
- DIAMOND [CUTTING / GRINDING]
- GRINDING ACCESSORIES
- SANDING / POLISHING ACCESSORIES
- SAWING ACCESSORIES
- ROUTERS / PLANERS ACCESSORIES
- CLEANERS ACCESSORIES
- HEAT GUN / LASERS ACCESSORIES
- BRAD NAILS/ PINS STAPLER
- GARDEN TOOLS ACCESSORIES
- HAND TOOLS / COMBINATION SETS

Abrasive Disc

For stone and plastics.



Outer Diameter (mm)	Grit	Pc Per Pkg	Max. RPM	Part No.
100	C24	10	13,700	794065-9
	C30	10	13,700	794066-7
	C50	10	13,700	794067-5
	C80	10	13,700	794068-3
	C100	10	13,700	794227-9
	C120	10	13,700	794069-1
115	C24	10	11,950	794104-5
	C30	10	11,950	794105-3
	C50	10	11,950	794106-1
	C80	10	11,950	794107-9
	C120	10	11,950	794108-7
125	C24	10	11,000	794096-8
	C30	10	11,000	794097-6
	C50	10	11,000	794098-4
	C80	10	11,000	794099-2
	C120	10	11,000	794100-3

Outer Diameter (mm)	Grit	Pc Per Pkg	Max. RPM	Part No.
150	C24	10	9,200	794070-6
	C30	10	9,200	794071-4
	C50	10	9,200	794072-2
	C80	10	9,200	794073-0
	C120	10	9,200	794074-8
	C16	10	7,600	794091-8
180	C20	10	7,600	794092-6
	C24	10	7,600	794093-4
	C30	10	7,600	794218-0
	C50	10	7,600	794094-2
	C80	10	7,600	794095-0
	C100	10	7,600	794220-3
	C120	10	7,600	794221-1

For wood, iron and steel

178	20	5	-	P-01074
	50	5	-	P-01068
	80	5	-	P-01080

Rubber Pad & Locknut for Angle Grinder



Wheel size	Spindle thread	Rubber pad			Sanding lock nut		Lock nut wrench	
		Size	Max. RPM	Part No.	Size	Part No.	Size	Part No.
9500N	M10 x 2.5	76mm	13700rpm	743009-6	30	224501-6	20	782401-1
115mm	M14 x 2 (DIN)	100mm	12000rpm	743036-3	48	224515-5	28/35	782412-6, 782424-9 / 782407-9, 782423-1
125mm	M14 x 2 (DIN)	115mm	12000rpm	743015-1	48	224515-5	28/35	782412-6, 782424-9 / 782407-9, 782423-1
150mm	M14 x 2 (DIN)	125mm	10950rpm	743016-9	48	224515-5	28/35	782412-6, 782424-9 / 782407-9, 782423-1
180 - 230mm	M14 x 2 (DIN)	170mm	8500rpm	743012-7	48	224515-5	28/35	782412-6 / 782407-9
180mm - 230mm	M16	170mm	8500rpm	743012-7	48	224523-6	28/35	782412-6 / 782407-9

Abrasive Disc (Hook & Loop Type) for angle grinders

For wood, iron and steel.

Dia. (mm)	Grit	Part No.
115	80	794594-2
125	40	794598-4

Pad for abrasive (hook & loop type)

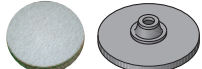
	Dia. (mm)	Part No.
	115	743062-2
	125	743061-4

Safety Flanges

Makita recommends the use of SAFETY FLANGES when using flat abrasive cutting wheels with large angle grinders. The safety flanges are larger in diameter compared to the standard flanges supplied with the machines. The larger diameter safety flanges offer greater support to the flat abrasive cutting wheels, thereby reducing the risks of wheel damage and ensuring operator safety.

We strongly recommend to use these flanges with the Thin Metal Cutting Wheels of sizes 180mm and 230mm

Main Benefits:

- ✓ Drastically reduces wheel breakage
- ✓ Straight line cutting due to less flexing
- ✓ Cuts a narrow groove due to blades stability
- ✓ Less wheel vibration – operator comfort
- ✓ Less vibration reduces machine wear



Inner Flange

Outer Flange

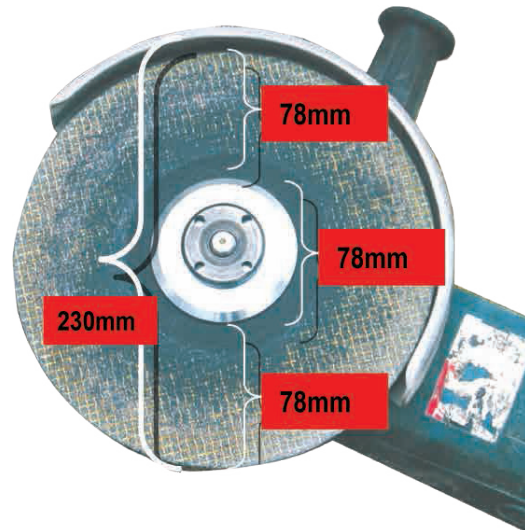

A: Outer Flange (Use with Lock nut 224543-0)

B: Inner Flange

Outer Diameter (mm)	Spindle Thread	For Grinder size	Type	Part No.
78	M14 X 2 (DIN)	180, 230mm	Outer Flange	224256-3
			Inner Flange	224257-1

Super Flanges

For Depressed Center Wheel & Diamond Wheel

Use of the Super Flange makes it easy to remove the Grinding Wheel etc. after grinding operations. The lock nut can be removed with only about one third of the force required to remove a conventional inner flange. The method of installation and use are the same as for the usual inner flange.



Outer Diameter (mm)	Spindle Thread	For Grinder size	Part No.
47	M14 X 2 (DIN)	115, 125, 150, 180, 230mm	192227-7

BATTERY /
CHARGERS

FIXING FASTENING
(SCREWDRIVER BITS
/ IMPACT SOCKETS)

DRILLING
(WOOD / METAL/
MASONRY)

DRILLING
/ DEMOLITION
[CONCRETE]

CUTTING
[METAL]

MULTI TOOL
ACCESSORIES

DIAMOND
[CUTTING / GRINDING]

GRINDING
ACCESSORIES

SANDING
/ POLISHING
ACCESSORIES

SAWING
ACCESSORIES

ROUTERS
/ PLANERS
ACCESSORIES

CLEANERS
ACCESSORIES

HEAT GUN / LASERS
ACCESSORIES

BRAD NAILS/ PINS
STAPLER

GARDEN TOOLS
ACCESSORIES

HAND TOOLS /
COMBINATION SETS

Safety Guidelines: Abrasive Wheels

Do's

- 1 Always handle and store all wheels in a very careful manner



3

- Visually check all wheels for damage or cracks before mounting and using them
- Allow newly mounted wheel to run for 1-min. in a protected area before use



4

- Always use a machine safety guard and back-up pad if required
- Use mounting flanges that are clean, flat of equal size and proper type
- Use safety flanges when using flat abrasive cutting wheels of 180 / 230mm diameter

- 2 Make sure machine speed does not exceed the RPM marked on the wheel



5

Always wear eye protection, protective clothing, safety gloves, and dust mask.



6

Prevent the dust from scattering by using dust extractors on the grinders to protect operators from respiratory diseases

Dont's

- 1 Do not use wheels that have been subjected to excessive humidity, moisture or temperature

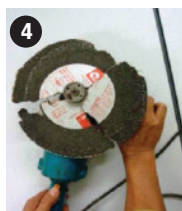

4

Do not use wheels that have been dropped or appear to have been damaged

- 2 Do not exceed the maximum operating speed marked on wheels



5

Do not force a wheel onto the machine or alter the hole size. Do not tighten the mounting nut excessively

- 3 Do not stand directly in front of wheel when machine is started



6

Do not grind or cut material for which the wheel is not designed. Do not use grinding wheel for cutting or notching

- Do not grind or cut without proper protective equipment

BATTERY / CHARGERS

FIXING FASTENING (SCREWDRIVER BITS / IMPACT SOCKETS)

DRILLING (WOOD / METAL / MASONRY)

DRILLING / DEMOLITION [CONCRETE]

CUTTING [METAL]

MULTI TOOL ACCESSORIES

DIAMOND [CUTTING / GRINDING]

GRINDING ACCESSORIES

SANDING / POLISHING ACCESSORIES

SAWING ACCESSORIES

ROUTERS / PLANERS ACCESSORIES

CLEANERS ACCESSORIES

HEAT GUN / LASERS ACCESSORIES

BRAD NAILS/ PINS STAPLER

GARDEN TOOLS ACCESSORIES

HAND TOOLS / COMBINATION SETS

Wire Cup Brush - Crimped Wire D- Series

- Ideal for flat surfaces, edges, light rust removal.

For Model: M10: 100mm M14: 115mm or higher.

A: 100mm

B: 115mm, 125mm, 150mm, 180mm

C: 180mm, 230mm



Outer Diameter (mm)	Spindle Thread	Type	Max. RPM	Part No.
60	M10 x 1.5	A	12,500	D-24066
60	M14 x 2	B	12,500	D-24072
75	M10 x 1.5	A	12,500	D-24088
75	M14 x 2	B	12,500	D-24094
75	M10 x 1.25	A	12,500	794160-5
75	M10 x 1.5	A	12,500	794162-1
90	M14 x 2	B	11,000	794371-2
90	M16 x 2	C	11,000	794324-1
110	M14 x 2	A	9,000	794372-0
110	M16 x 2	A	9,000	794325-9

Wire Cup Brush - Twisted (Knotted wire)

- Can be used for heavy duty cleaning of large metal surfaces, rust and paint removal, removal of weld scale and corrosion, surface preparation for painting and welding, auto body finish and repair.

- 0.3mm crimped steel wire

For Model:

A: M10: 100mm

B: M14: 115mm or higher.



Outer Diameter (mm)	Spindle Thread	Type	Max. RPM	Part No.
60	M10 x 1.5	A	12,500	D-24103
60	M14 x 2	B	12,500	D-24119
75	M10 x 1.5	A	12,500	D-24125
75	M14 x 2	B	12,500	D-24131

Wire Cup Brush - Twisted (Knotted wire 2)

- Can be used for heavy duty cleaning of large metal surfaces, rust and paint removal, removal of weld scale and corrosion, surface preparation for painting and welding, auto body finish and repair.

- 0.3mm crimped steel wire

For Model:

A: M10: 100mm

B: M14: 115mm or higher.



Outer Diameter (mm)	Spindle Thread	Type	Max. RPM	Part No.
60	M10 x 1.5	A	12,500	D-24147
60	M14 x 2	B	12,500	D-24153

BATTERY /
CHARGERS

FIXING FASTENING
(SCREWDRIVER BITS
/ IMPACT SOCKETS)

DRILLING
(WOOD / METAL/
MASONRY)

DRILLING
/ DEMOLITION
[CONCRETE]

CUTTING
[METAL]

MULTI TOOL
ACCESSORIES

DIAMOND
[CUTTING / GRINDING]

GRINDING
ACCESSORIES

SANDING
/ POLISHING
ACCESSORIES

SAWING
ACCESSORIES

ROUTERS
/ PLANERS
ACCESSORIES

CLEANERS
ACCESSORIES

HEAT GUN / LASERS
ACCESSORIES

BRAD NAILS/ PINS
STAPLER

GARDEN TOOLS
ACCESSORIES

HAND TOOLS /
COMBINATION SETS

BATTERY
/ CHARGERSFIXING FASTENING
(SCREWDRIVER BITS
/ IMPACT SOCKETS)DRILLING
(WOOD / METAL/
MASONRY)DRILLING
/ DEMOLITION
[CONCRETE]CUTTING
[METAL]MULTI TOOL
ACCESSORIESDIAMOND
[CUTTING / GRINDING]GRINDING
ACCESSORIESSANDING
/ POLISHING
ACCESSORIESSAWING
ACCESSORIESROUTERS
/ PLANERS
ACCESSORIESCLEANERS
ACCESSORIESHEAT GUN / LASERS
ACCESSORIESBRAD NAILS/ PINS
STAPLERGARDEN TOOLS
ACCESSORIESHAND TOOLS /
COMBINATION SETS

Wire Cup Brush (Crimped Cup) T-series

- For heavy duty professional use
- Suitable for wood, paint, rust removal & many other applications.

- 0.5mm knotted steel wire

For Model: **A:** 115, 125mm **B:** 180mm **C:** 180, 230mm



Outer Diameter (mm)	Spindle Thread	Type	Max. RPM	Part No.
60	M14 -5/8" -11	A	14,000	T-01993
100	M14 -5/8" -11	B	8,500	T-02004
120	M14 -5/8" -11	C	8,500	T-02010

Wire Bevel Cup Brush (Crimped Cup) T-series

- For heavy duty professional use
- Suitable for wood, paint, rust removal and many other applications.

For Model: **A:** 115, 125mm



Outer Diameter (mm)	Spindle Thread	Type	Max. RPM	Part No.
90	M14 -5/8" -11	A	14,000	T-02026

Wire Cup Brush (Twisted) P-series

- For heavy duty professional use
- Strong brushes with the highest safety working standards
- Heavy duty cleaning of large metal surfaces
- Ideal to remove slags rust paint and hard incrustations/layers.
- Knot cup (0.5mm Steel)

Outer Diameter (mm)	Spindle Thread	Type	Max. RPM	Part No.
75	M14-5/8"-11	A	12,500	P-04488
85	M14-5/8"-11	B	8,500	P-04472



Wire Bevel Cup Brush (Twisted) P-series

- For heavy duty professional use
- Strong brushes with the highest safety working standards
- Heavy duty cleaning of large metal surfaces
- Ideal to remove slags rust paint and hard incrustations/layers.
- Knot cup (0.5mm Steel)

Outer Diameter (mm)	Spindle Thread	Type	Max. RPM	Part No.
95	M14-5/8" -11	-	12,500	P-04494



Grinding Wheel for Straight Grinder

A: Metal



For Model	Size (mm)	Grit	Max. RPM	Part No.
9105	125 x 19	A24P	5,090	741015-5
		A36P	5,090	741016-3
GS5000	125 x 20	A24P	5,660	B-33990
		A36P	5,660	B-34001
GS6000	125 x 50	A24P	5,660	B-34017
		A36P	5,660	B-34023



Grinding Wheel for Bench Grinder

A: To grind mild steel, carbon steel, etc.
GC: Fine Aluminum, Copper, Brass
WA: Metal, Stainless Steel



For Model	Size (mm)	Grit	Max. RPM	Part No.
GB602	150 x 16	A36M	4,250	B-51904
		A60M	4,250	B-51910
		GC120H	4,250	B-51932
		WA60K		B-51926 NEW
9306S	150 x 6.4	A60M	4,250	A-47195
GB801	205 x 19	A36P		B-51948
		A60P	3,720	B-51954
		GC120H	3,720	B-51976
		WA60K		B-51960 NEW
GB600	150 x 19	A36Q	4,200	(GB)6005R
		A60P	4,200	(GB)6005L
GB601	150 x 25.4	A36Q	4,200	(GB)6105R
		A60P	4,200	(GB)6105L
GB800	205 x 25.4	A36Q	3,700	(GB)8005R
		A60P	3,700	(GB)8005L

Eye shield assembly for bench grinders

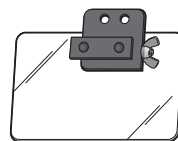

For Model	Part No.
9306 , 9308	122203-7
GB800	(GB)8050

BATTERY /
CHARGERS

FIXING FASTENING
(SCREWDRIVER BITS
/ IMPACT SOCKETS)

DRILLING
(WOOD / METAL/
MASONRY)

DRILLING
/ DEMOLITION
(CONCRETE)

CUTTING
(METAL)

MULTI TOOL
ACCESSORIES

DIAMOND
(CUTTING / GRINDING)

GRINDING
ACCESSORIES

SANDING
/ POLISHING
ACCESSORIES

SAWING
ACCESSORIES

ROUTERS
/ PLANERS
ACCESSORIES

CLEANERS
ACCESSORIES

HEAT GUN / LASERS
ACCESSORIES

BRAD NAILS/ PINS
STAPLER

GARDEN TOOLS
ACCESSORIES

HAND TOOLS /
COMBINATION SETS

BATTERY / CHARGERS

FIXING FASTENING (SCREWDRIVER BITS / IMPACT SOCKETS)

DRILLING (WOOD / METAL/ MASONRY)

DRILLING / DEMOLITION (CONCRETE)

CUTTING [METAL]

MULTI TOOL ACCESSORIES

DIAMOND [CUTTING / GRINDING]

GRINDING ACCESSORIES

SANDING / POLISHING ACCESSORIES

SAWING ACCESSORIES

ROUTERS / PLANERS ACCESSORIES

CLEANERS ACCESSORIES

HEAT GUN / LASERS ACCESSORIES

BRAD NAILS/ PINS STAPLER

GARDEN TOOLS ACCESSORIES

HAND TOOLS / COMBINATION SETS

Tungsten Carbide Burrs for Die Grinders

- i) Clean the burrs on Inox / Metal pipe
- ii) Wipe the welding line between steel plate
- iii) Remove the scar of iron pipe inner side
- iv) Deburr of aluminium product



10pcs pkg

- Available in different shapes and sizes
- Comes in a pack of 10pcs
- Used on die grinder - max speed less than 33,000rpm
- Standard cut burrs quickly remove stock
- Can be used on different metal such as steel, inox

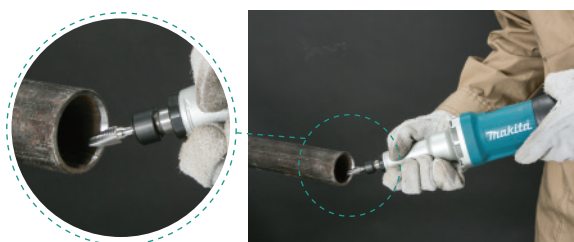

Suitable for Die Grinders models: GD0800C, GD0801C, GD0600, GD0602

Not suitable for 906, 906H, GD0810C / GD0811C

Size	Head Shape	pc /Pkg	Part no
12x25x6mm		10	B-62402-10
12x25x6mm		10	B-62418-10
12x25x6mm		10	B-62424-10
12x28x6mm		10	B-62430-10
12x25x6mm		10	B-62446-10

Wheel point for Die Grinders

For model: 906H, GD0600, GD0602, GD0800C, GD0810C, DGD800

Abrasive material

A: To grind mild steel, carbon steel, etc.
WA: To grind hardened and special steels.

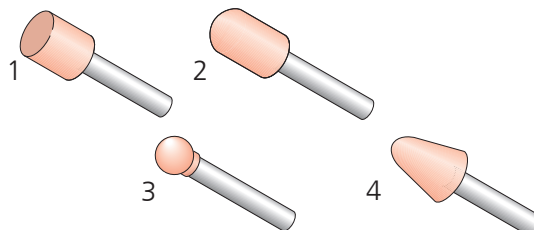

No.	Wheel Dia.(mm)	Shank Size(mm)	Abrasive Material	Pc/Pkg	Part No.
1	5	3	A	10	794050-2
1	6	3	A	10	794051-0
1	8	3	A	10	794052-8
1	10	3	A	10	794053-6
2	5	3	WA	10	794054-4
2	6	3	WA	10	794055-2
2	8	3	WA	10	794056-0
2	10	3	WA	10	794057-8
3	5	3	A	10	A-23450
3	10	3	A	10	794059-4
1	19	6	WA	1	741614-3
1	19	1/4"	WA	1	741617-7
4	19	6	WA	1	741615-1
4	19	1/4"	WA	1	741616-9

Vise Holder set for Die Grinders



For Model

GD0800C, GD0810C

Part No.

193141-0

Collet Cone for Die Grinders

A: Collet cone assembly Including Collet Nut 763645-2



For Model	Size	Type	Part No.
903	3mm	-	763610-1
906, 906H, GD0600, GD0601	1/8"	-	763626-6
	3mm	-	763627-4
	6mm	-	763620-8
GD0602, BGD800Z	1/4"	-	763625-8
	6mm	-	763670-3
GD0800C, GD0810C	3mm	A	193011-3
	6mm	A	193012-1
	1/4"	A	193143-6
	8mm	A	192988-9
	1/8"	A	193144-4

Straight cup wheel for Stone Grinder





For model GC500 (Discontinued)



Dia. x Thickness x Hole dia.	Type	Part No.
125 x 70 x 22 mm	GC20/24	794329-1
125 x 70 x 22 mm	GC46/60	794330-6

TCT Blade Sharpner Accessories

For model 9803 (Discontinued)

Accessories	For saw blade hole dia	Part No.
Ring 	1" (25.4mm)	257123-7
Flange 30 	-	224062-6
Sleeve 15 	-	257617-2
Dressing Stone 	-	794370-4

Dust Cover Attachment

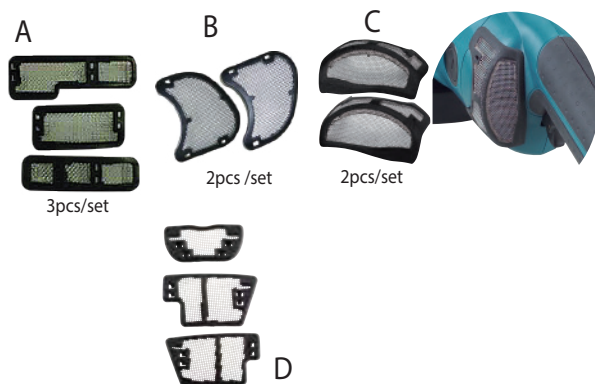

Suitable for	Type	Part No.
9561/C/CV, 9562/C/CV, 9563H/C/CV, 9564H/C/CV, 9564CVL, 9565H/C/CV/CVL, GD0800, GD0800C, GD0810C	A	193903-6
GA7010C, GA9010C	B	193956-5
GA7020, GA7021, GA9020, GA7030/S, GA7040S, GA9030/S, GA9040S	C	194289-1
GA4050/R, GA4550/R, GA5050/R	D	199514-5

Dust Bag Assembly

For Dustless cutter and Concrete planer



Suitable for	Part No.
PC1100	122193-4
PC5000C, PC5001C	122853-8

BATTERY /
CHARGERS

FIXING FASTENING
(SCREWDRIVER BITS
/ IMPACT SOCKETS)

DRILLING
(WOOD / METAL/
MASONRY)

DRILLING
/ DEMOLITION
[CONCRETE]

CUTTING
[METAL]

MULTI TOOL
ACCESSORIES

DIAMOND
[CUTTING / GRINDING]

GRINDING
ACCESSORIES

SANDING
/ POLISHING
ACCESSORIES

SAWING
ACCESSORIES

ROUTERS
/ PLANERS
ACCESSORIES

CLEANERS
ACCESSORIES

HEAT GUN / LASERS
ACCESSORIES

BRAD NAILS/ PINS
STAPLER

GARDEN TOOLS
ACCESSORIES



HAND TOOLS /
COMBINATION SETS

- BATTERY / CHARGERS
- FIXING FASTENING (SCREWDRIVER BITS / IMPACT SOCKETS)
- DRILLING (WOOD / METAL / MASONRY)
- DRILLING / DEMOLITION [CONCRETE]
- CUTTING [METAL]
- MULTI TOOL ACCESSORIES
- DIAMOND [CUTTING / GRINDING]
- GRINDING ACCESSORIES
- SANDING / POLISHING ACCESSORIES
- SAWING ACCESSORIES
- ROUTERS / PLANERS ACCESSORIES
- CLEANERS ACCESSORIES
- HEAT GUN / LASERS ACCESSORIES
- BRAD NAILS/ PINS STAPLER
- GARDEN TOOLS ACCESSORIES
- HAND TOOLS / COMBINATION SETS

Dust collecting wheel guard for Diamond Cup Wheel

	Suitable For	Part No.
	115, 125mm Angle Grinders with single notch on bearing box	195237-3
	115, 125mm XGT Angle Grinders, GA4550/R, GA5050/R	NEW 191F81-2
Brush Set for diamond cup wheel (For 115mm, 125mm Grinders): 196880-1		

Dust collecting wheel guard

	Suitable For	Part No.
	N9500N, 9500NB	192212-0 to be used with rubber sleeve 192202-3
	100mm Grinders	192475-8
	115, 125mm Grinders	192618-2
	115, 125mm Grinders with 3 notches on bearing box	196846-1
	115, 125mm Grinders with single notch on bearing box	196845-3
	115, 125mm XGT Grinders, GA4550/R, GA5050/R	NEW 191G06-2
	115, 125mm X-Lock Grinders	NEW 191G05-4
	115, 125mm Grinders	193794-5
	180mm Grinders	194303-3

Dust Collecting Wheel guard

For DGA900 & AC 230mm Angle Grinders only
 Max cutting depth: 60mm
 Plunge cutting can be done without lifting Base (Use with Inner flange 45cc Part No. 198675-8)



Plunge cutting can be done without lifting Base



Suitable For	Part No.
230mm Angle Grinders with single notch on bearing box	198380-7

New tool-less wheel cover (Slide lever style)

For fast and easy angle adjustment and installation / removal of wheel cover
(Currently available for XGT and X-Lock Grinders)

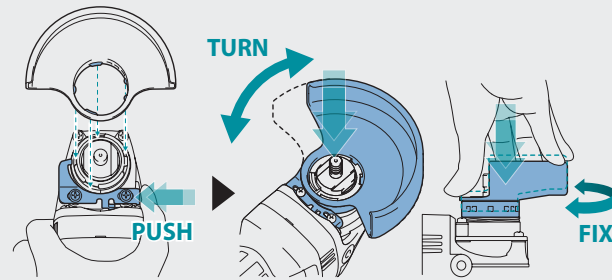

Wheel guard

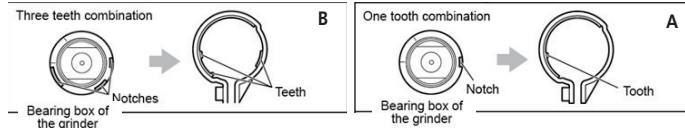

Suitable For	For Model	Bear Type	Type	Part No.
100mm Grinders	N9500N	B		154755-0
	9520B			165171-1
	9553HN, 9556HN, 9556HP	B		125266-2
	GA4030, GA4034, GA4040 GA4040C 9553HN, 9556HN, 9556HP	A		125885-4
	9563C, 9563HZ	A	Tool Less	122893-6
	GA4050/R		New Tool Less	NEW 347478-9
115mm Grinders	9521NB			165053-7
	9564H, 9564C, 9564CV, 9564P, 9554HN, 9557HN, 9557HP	B		125267-0
		B	Tool Less	135107-4
	GA4530 GA4534 GA4540 GA4540C, 9554HN, 9557HN, 9557HP, 9561CR, 9564H, 9564P, 9564PC, DGA452, DGA454, DGA455, DGA456, DGA458	A		123098-1
	DGA469 - X-LOCK	A	Tool Less	123144-0
	GA004G / 12G / 22G / 28G - XGT, GA4550/R		New Tool Less	NEW 347479-7
125mm Grinders	9522NB, 9015B			125097-9
	9555HN, 9558HN, 9558HP, 9565HZ, 9562CR, 9565CV/CVL			125268-8
	GA5010 GA5020 GA5030, GA5040, GA5040C 9555HN, 9558HN, 9558HP, 9558NB, 9562CR, 9565C, 9565CLR, 9565CV 9565CVL 9565H 9565P 9565PC	A		122887-1
		A		23099-9
			Tool Less	135242-8
	DGA519 - X-LOCK		New Tool Less	NEW 162708-5
GA005G / 13G / 23G / 29G - XGT, GA5050/R		New Tool Less	NEW 347480-2	
150mm Grinders	9016B			134961-3
	GA6010	C		135192-7
180mm Grinders	9607HB, GA7001			164825-7
	DGA700, GA7020, GA7030, GA7040S, GA7050, GA7063, GA7064	A		122889-7
	GA7020, GA7030, GA7040S		Tool Less	1634462
230mm Grinders	9609HB			164814-2
	DGA900 GA9020, GA9030, GA9040S, GA9050, GA9063, GA9064	A		122891-0
	GA7020, GA7030, GA7040S			135280-0

BATTERY /
CHARGERSFIXING FASTENING
(SCREWDRIVER BITS
/ IMPACT SOCKETS)DRILLING
(WOOD / METAL/
MASONRY)DRILLING
/ DEMOLITION
[CONCRETE]CUTTING
[METAL]MULTI TOOL
ACCESSORIESDIAMOND
[CUTTING / GRINDING]GRINDING
ACCESSORIESSANDING
/ POLISHING
ACCESSORIESSAWING
ACCESSORIESROUTERS
/ PLANERS
ACCESSORIESCLEANERS
ACCESSORIESHEAT GUN / LASERS
ACCESSORIESBRAD NAILS/ PINS
STAPLERGARDEN TOOLS
ACCESSORIESHAND TOOLS /
COMBINATION SETS

BATTERY
/ CHARGERSFIXING FASTENING
(SCREWDRIVER BITS
/ IMPACT SOCKETS)DRILLING
(WOOD / METAL/
MASONRY)DRILLING
/ DEMOLITION
(CONCRETE)CUTTING
(METAL)MULTI TOOL
ACCESSORIESDIAMOND
(CUTTING / GRINDING)GRINDING
ACCESSORIESSANDING
/ POLISHING
ACCESSORIESSAWING
ACCESSORIESROUTERS
/ PLANERS
ACCESSORIESCLEANERS
ACCESSORIESHEAT GUN / LASERS
ACCESSORIESBRAD NAILS/ PINS
STAPLERGARDEN TOOLS
ACCESSORIESHAND TOOLS /
COMBINATION SETS

Grip



Grip



AVT Grip

Suitable for	Standard Grip	Rubberized Grip	Anti Vibration Grip
100, 115, 125mm Grinders	153489-2	158237-4	194514-0
GA4030, GA4034, GA4530, GA4534, GA5010, GA5011, GA6010	153504-2	158237-4	194514-0
9005B, 9005N, N9500N, 9015B, GA7001	152492-0	-	-
GA7050, GA7050R, 9067, GA7020, GA9050, GA9050R, 9069, GA9020	152539-0	-	162264-5
GA9062, GA7062, GA9063, GA7063, DGA700, DGA900	143846-6	-	162264-5
GA9030, GA9040S, GA7030, GA7040S	-	-	162264-5
9005B	273503-9	-	-

Lock nut wrench

- Used with Grinders / Concrete Planers, Wall Chaser



For Model	Size	Part No.
100mm Grinders	20	782420-7
100mm Grinders / PC1100	20	782401-1
115 / 125mm Grinders	35	782423-1
180 / 230mm Grinders	35	782407-9
DIN / OLD Type	28	782412-6
PC5000C / PC5001C	35	782426-5

Wrench

- Used with Die Grinders, Straight Grinders, Cutters, Wall Chaser



A

For model	Size	Type	Part No.
906 / 906H	10		781003-0
906 / 906H	17	A	781008-0
GD0600 / GD0602	13		781039-9
GD0800C / GD08010C	13		781203-2

Lock nut release socket

- Used with Grinders

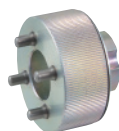

(Square drive :12.7mm)

For Model	Size	Part No.
180 / 230mm Grinders	28	194305-9

Sanding / Polishing Accessories

Abrasive Belts / Abrasive Pad / Polishing Pad

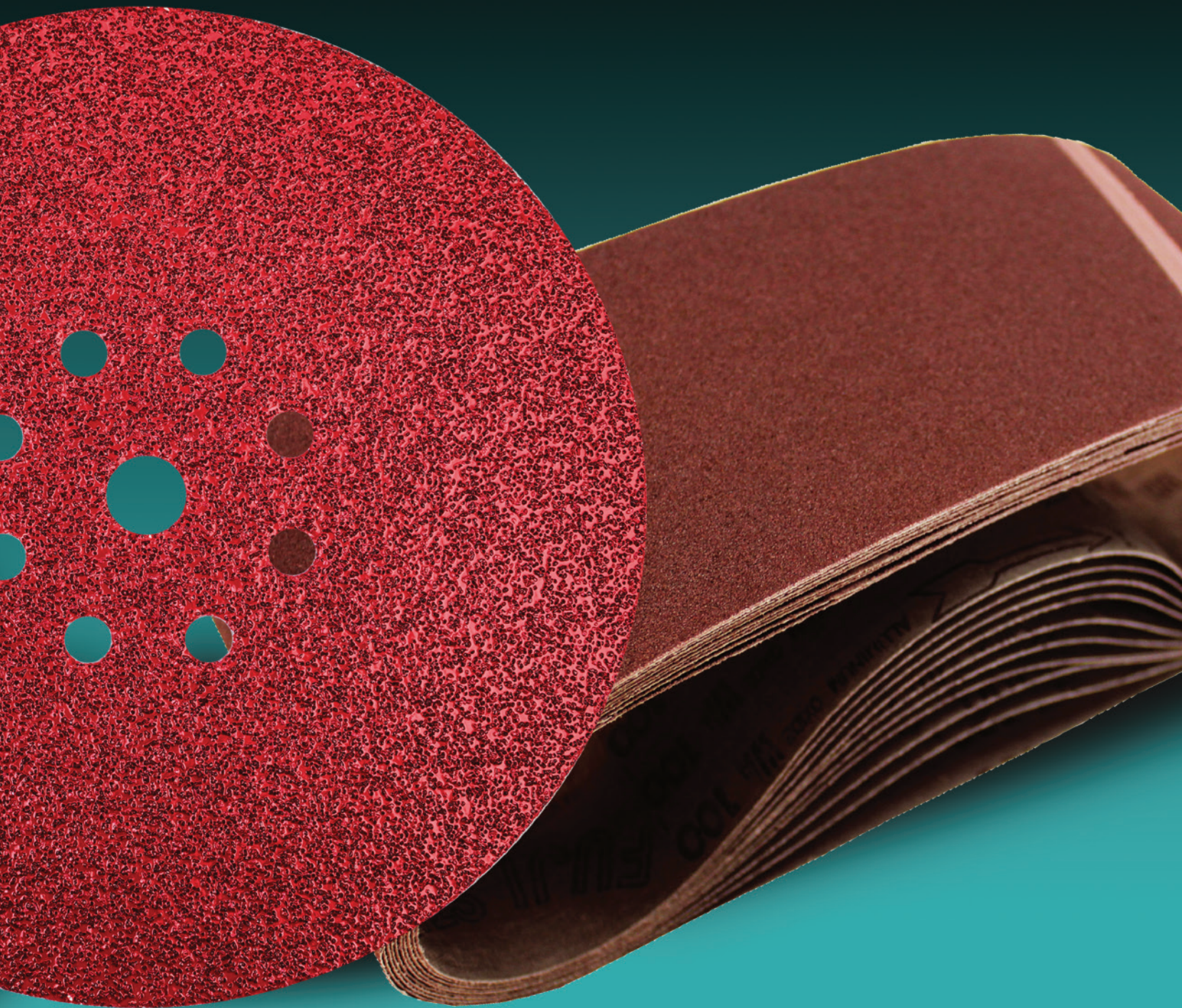

BATTERY / CHARGERS

FIXING FASTENING (SCREWDRIVER BITS / IMPACT SOCKETS)

DRILLING (WOOD / METAL / MASONRY)

DRILLING / DEMOLITION (CONCRETE)

CUTTING [METAL]

MULTI TOOL ACCESSORIES

DIAMOND (CUTTING / GRINDING)

GRINDING ACCESSORIES

SANDING / POLISHING ACCESSORIES

SAWING ACCESSORIES

ROUTERS / PLANERS ACCESSORIES

CLEANERS ACCESSORIES

HEAT GUN / LASERS ACCESSORIES

BRAD NAILS/ PINS STAPLER

GARDEN TOOLS ACCESSORIES

HAND TOOLS / COMBINATION SETS

Abrasive Belt for Belt Sander

AA, WA: For wood, iron and steel
CC: For stone and plastics

For Model: 9032, DBS180

Belt Size (mm)	Grit	Part No.	Pcs per pkg.
6mm x 533mm 	AA40	A-34512	10
	AA60	A-34528	10
	AA80	A-34534	10
	AA100	A-34540	10
	AA120	A-34556	10
9mm x 533mm 	AA40	A-34447	10
	AA60	A-34453	10
	AA80	A-34469	10
	AA100	A-34475	10
13mm x 533mm 	AA40	A-34562	10
	AA60	A-34578	10
	AA80	A-34584	10
	A100	A-34590	10
	AA120	A-34609	10

For Model: 9030, 9031

Belt Size (mm)	Grit	Part No.	Pcs per pkg.
30mm x 533mm 	AA40	794109-5	10
	AA60	794111-8	10
	CC100	794282-1	10
	AA40	P-36675	5
	AA60	P-36681	5
	AA80	P-36697	5
	AA100	P-36706	5
	AA120	P-36712	5
	AA150	P-36728	5
	AA240	P-36734	5
	CC40	A-23927	5
	CC60	A-23933	5
	CC80	A-23949	5
	CC120	A-23961	5
	CC240	A-23983	5

For Model: 9901

Belt Size (mm)	Grit	Part No.	Pcs per pkg.
76mm X 533mm 	AA40	794119-2	10
	AA60	794120-7	10
	AA80	794121-5	10
	AA100	794122-3	10
	AA120	794123-1	10
	AA150	794125-7	10

For Model: 9910 (Belt Sander)

Belt Size (mm)	Grit	Part No.	Pcs per pkg.
76mm x 457mm 	AA40	794552-8	10
	AA180	794556-0	10
	AA240	794557-8	10
	WA40	P-37091	5
	WA60	P-37100	5
	WA80	P-37116	5
	WA100	P-37122	5
	WA120	P-37138	5
	WA150	P-37144	5
	WA240	P-37150	5

For Model: 9920, 9924DB (Belt Sander)

Belt Size (mm)	Grit	Part No.	Pcs per pkg.
76mm X 610mm 	AA120	794241-5	10
	AA150	794242-3	10
	AA240	794244-9	10
	CC40	794245-7	10
	CC60	794246-5	10
	CC80	794247-3	10
	CC100	794248-1	10
	CC120	794249-9	10
	CC150	794250-4	10
	CC180	794251-2	10
	CC240	794252-0	10
	WA40	P-37312	5
	WA60	P-37328	5
	WA80	P-37334	5
	WA100	P-37340	5
	WA120	P-37356	5
	WA150	P-37362	5
	WA240	P-37378	5

For Model: 9401, 9403, 9404

Belt Size (mm)	Grit	Part No.	Pcs per pkg.
100mm X 610mm 	WA40	794133-8	5
	WA180	794222-9	5
	CC40	• 794140-1	5
	CC80	794142-7	5
	CC180	• 794223-7	5
	WA40	P-36887	5
	WA60	P-36893	5
	WA80	P-36902	5
	WA100	P-36918	5
	WA120	P-36924	5
	WA150	P-36930	5
	WA240	P-36946	5

Abrasive Paper

Grit: 40-60: Course | 80-120: Medium | 150-240: Fine

For Model: BO4510, BO4553, BO4556

Belt Size (mm)	Grit	Part No.	Pcs per pkg.
 114mm X 140mm	60	794195-6	6
	150	794214-8	10
	40	P-36398	10
	60	P-32904	10
	80	P-36407	10
	100	P-32910	10
	120	P-32926	10
	150	P-32932	10
	180	P-36413	10
	240	P-36429	10

For Model: 9035, 9036, BO3710, BO3700

Belt Size (mm)	Grit	Part No.	Pcs per pkg.
 93mm X 228mm	60	794156-6	10
	100	794157-4	10
	150	794158-2	10
	40	P-36136	10
	60	P-32948	10
	80	P-36142	10
	100	P-32954	10
	120	P-36158	10
	150	P-32960	10
	180	P-36164	10
240	P-36170	10	

For Model: BO4900, BO4901, 9046

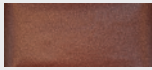
Belt Size (mm)	Grit	Part No.	Pcs per pkg.
 114 X 280	100	794209-1	10
	150	794213-0	10
	180	794211-4	10
	40	P-36267	10
	60	P-32976	10
	80	P-36273	10
	100	P-32982	10
	120	P-36289	10
	150	P-32998	10
	180	P-36295	10
240	P-36304	10	

For Model: BO4560

Belt Size (mm)	Grit	Part No.	Pcs per pkg.
 87mm X 160mm	40	794494-6	10
	60	794391-6	10
	80	794495-4	10
	100	794392-4	10
	120	794496-2	10
	150	794393-2	10

Abrasive Paper - Pre Punched

Grit: 40-60: Course | 80-120: Medium | 150-240: Fine

For Model: 9035, 9036, BO3700, BO3710

Belt Size (mm)	Grit	Part No.	Pcs per pkg.
 93mm X 230mm	180	794564-1	10
	40	P-31837	10
	60	P-31843	10
	80	P-31859	10
	100	P-31865	10
	120	P-36011	10
	150	P-36027	10
	180	P-36033	10
	240	P-36049	10

For Model: BO4900, BO4901, 9046

Belt Size (mm)	Grit	Part No.	Pcs per pkg.
 115mm X 280mm	60	A-14065	10
	100	A-14087	10
	150	A-14102	10
	40	P-33009	10
	60	P-33015	10
	80	P-33021	10
	100	P-33037	10
	120	P-33043	10
	150	P-33059	10
	180	P-33065	10
	240	P-33071	10

For Model: BO4563, BO4566

(For BO4566 the abrasive paper needs to be cut to 164mm length)

Belt Size (mm)	Grit	Part No.	Pcs per pkg.
 100mm X 240mm	40	P-20644	10
	60	P-20650	10
	80	P-20666	10
	120	P-20688	10
	150	P-20694	10
	180	P-20703	10
	240	P-20719	10
	40	P-42868	10
	60	P-42874	10
	80	P-42880	10
	100	P-42896	10
	120	P-42905	10
	150	P-42911	10
	180	P-42927	10
	240	P-42933	10

BATTERY /
CHARGERS

FIXING FASTENING
(SCREWDRIVER BITS
/ IMPACT SOCKETS)

DRILLING
(WOOD / METAL/
MASONRY)

DRILLING
/ DEMOLITION
(CONCRETE)

CUTTING
(METAL)

MULTI TOOL
ACCESSORIES

DIAMOND
(CUTTING / GRINDING)

GRINDING
ACCESSORIES

SANDING
/ POLISHING
ACCESSORIES

SAWING
ACCESSORIES

ROUTERS
/ PLANERS
ACCESSORIES

CLEANERS
ACCESSORIES

HEAT GUN / LASERS
ACCESSORIES

BRAD NAILS/ PINS
STAPLER

GARDEN TOOLS
ACCESSORIES

HAND TOOLS /
COMBINATION SETS

Abrasive Paper 230mm x 280mm for Finishing Sander

How to cut abrasive paper

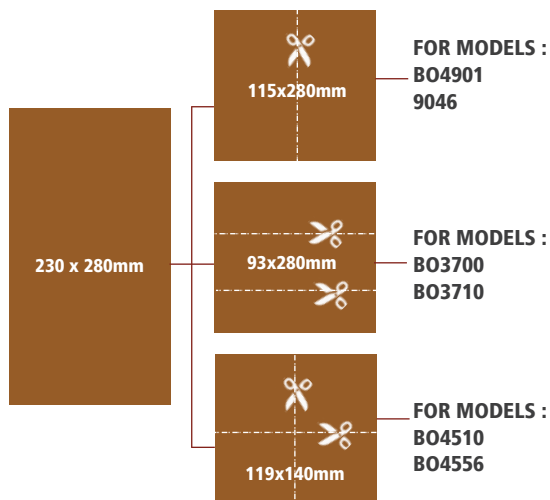

Stearted Aluminium Oxide Abrasive paper 230x280mm

Application: Coating, (Paint & Varnish)
For Model: All Finishing Sander, Handuse

Belt Size (mm)	Grit	Part No.	Pcs per pkg.
 230mm x 280mm	80	D-60698	100
	100	D-60707	100
	120	D-60713	100
	150	D-60729	100
	180	D-60735	100
	220	D-60741	100
	240	D-60757	100
	280	D-60763	100
	320	D-60779	100
	360	D-60785	100
	400	D-60791	100
	500	D-60800	100
	600	D-60816	100
800	D-60822	100	

Aluminium Oxide Abrasive paper 230x280mm

Application: For wood
For Model: All Finishing Sander, Handsanding

Belt Size (mm)	Grit	Part No.	Pcs per pkg.
 230mm x 280mm	40	D-52358	50
	60	D-52364	50
	80	D-52370	50
	100	D-52386	50
	120	D-52392	50
	150	D-52401	50
	180	D-52417	50
	240	D-52423	50
	320	D-56895	50
	400	D-56904	50

Aluminium Oxide Abrasive paper 230x280mm

Application: For metal
For Model: All Finishing Sander, Handsanding

Belt Size (mm)	Grit	Part No.	Pcs per pkg.
 230mm x 280mm	36	D-56764	50
	40	D-56770	50
	60	D-56786	50
	80	D-56792	50
	100	D-56801	50
	120	D-56817	50
	150	D-56823	50
	180	D-56839	50
	240	D-56845	50

Aluminium Oxide Abrasive paper 230x280mm

Application: For mortar
For Model: All Finishing Sander, Handsanding

Belt Size (mm)	Grit	Part No.	Pcs per pkg.
 230mm x 280mm	60	D-56605	50
	80	D-56611	50
	100	D-56627	50
	120	D-56633	50
	150	D-56649	50
	180	D-56655	50
	240	D-56661	50

Waterproof Silicon Carbide Abrasive paper 230x280mm

Application: For car body (Glass, Stone, Marble, Granite)
For Model: All Finishing Sander, Handuse

Belt Size (mm)	Grit	Part No.	Pcs per pkg.
 230mm x 280mm	80	D-58942	50
	100	D-58958	50
	120	D-58964	50
	180	D-58986	50
	220	D-58992	50
	280	D-59003	50
	320	D-59019	50
	400	D-59025	50
	800	D-59047	50
	1000	D-59053	50
	1200	D-56867	50
	1500	D-59069	50
	2000	D-59075	50

- BATTERY / CHARGERS
- FIXING FASTENING (SCREWDRIVER BITS / IMPACT SOCKETS)
- DRILLING (WOOD / METAL / MASONRY)
- DRILLING / DEMOLITION (CONCRETE)
- CUTTING [METAL]
- MULTI TOOL ACCESSORIES
- DIAMOND [CUTTING / GRINDING]
- GRINDING ACCESSORIES
- SANDING / POLISHING ACCESSORIES
- SAWING ACCESSORIES
- ROUTERS / PLANERS ACCESSORIES
- CLEANERS ACCESSORIES
- HEAT GUN / LASERS ACCESSORIES
- BRAD NAILS/ PINS STAPLER
- GARDEN TOOLS ACCESSORIES
- HAND TOOLS / COMBINATION SETS

Abrasive Disc - Pre Punched, Hook & Loop**Abrasive paper grit**

- 40-60: Course
- 80-120: Medium
- 150-240: Fine

For Model: BO3700, BO3710
Use with pad set **192983-9**

	Grit	Part No.	Pcs per pkg.
 93 x 185mm	40	P-31871	10
	60	P-31887	10
	80	P-31893	10
	100	P-31902	10
	120	P-35891	10
	150	P-35900	10
	180	P-35916	10
	240	P-35922	10

For Model: BO4900, BO4901, 9046
Use with pad set **193521-0**

	Grit	Part No.	Pcs per pkg.
 15 x 232mm	80	A-14146	5
	100	A-14152	5
	120	A-14168	5
	180	A-14180	5
	240	A-14196	5
	40	P-33174	10
	60	P-33180	10
	80	P-33196	10
	100	P-33205	10
	120	P-33211	10
	150	P-33227	10
	180	P-33233	10
240	P-33249	10	

**Abrasive Disc - Pre-punched (9 hole)
for dry wall sander DSL800**

- Made of high quality, durable rubber for long life.
- Hook and loop design for quick and easy abrasive paper changes.
- 40-60: Course
- 80-120: Medium
- 150-240: Fine

NEW

For Model: DSL800 (Ceramic grain paper)

Pad Size (mm)	Grit	Part No.	Pcs per pkg.
 255mm with 9 holes	40	B-68389	25
	80	B-68395	25
	120	B-68404	25
	180	B-68410	25
	320	B-68426	25

Abrasive Disc - Pre Punched, Hook & Loop

For Model: BO5010, BO5021, BO5030, BO5041

Pad Size (mm)	Grit	Part No.	Pcs per pkg.
 125mm	40	P-43533	10
	60	P-43549	10
	80	P-43555	10
	100	P-43561	10
	120	P-43577	10
	180	P-43583	10
	240	P-43599	10
	240	794546-3	10
	320	P-43608	10
	400	P-43614	10

For Model: BO6030, BO6040

Belt Size (mm)	Grit	Part No.	Pcs per pkg.
 150mm	40	P-31918	10
	40	794607-9	10
	60	P-31924	10
	80	P-31930	10
	100	P-31946	10
	120	P-31952	10
	120	794610-0	10
	150	P-31968	10
	180	P-31974	10
	220	P-31980	10
	240	P-31996	10
	320	P-32007	10
	400	P-32013	10
	400	794613-4	10

BO6050, BO6040, BO6030

For Wood

	Grit	Part No.	Pcs per pkg.
 150mm with 15 holes	40	B-51415	10
	60	B-51421	10
	80	B-51437	10
	100	B-51443	10
	120	B-51459	10
	180	B-51465	10
	240	B-51471	10
	320	B-51487	10
	400	B-51493	10

BATTERY /
CHARGERSFIXING FASTENING
(SCREWDRIVER BITS
/ IMPACT SOCKETS)DRILLING
(WOOD / METAL/
MASONRY)DRILLING
/ DEMOLITION
(CONCRETE)CUTTING
(METAL)MULTI TOOL
ACCESSORIESDIAMOND
(CUTTING / GRINDING)GRINDING
ACCESSORIESSANDING
/ POLISHING
ACCESSORIESSAWING
ACCESSORIESROUTERS
/ PLANERS
ACCESSORIESCLEANERS
ACCESSORIESHEAT GUN / LASERS
ACCESSORIESBRAD NAILS/ PINS
STAPLERGARDEN TOOLS
ACCESSORIESHAND TOOLS /
COMBINATION SETS

BATTERY
/ CHARGERSFIXING FASTENING
(SCREWDRIVER BITS
/ IMPACT SOCKETS)DRILLING
(WOOD / METAL/
MASONRY)DRILLING
/ DEMOLITION
(CONCRETE)CUTTING
(METAL)MULTI TOOL
ACCESSORIESDIAMOND
(CUTTING / GRINDING)GRINDING
ACCESSORIESSANDING
/ POLISHING
ACCESSORIESSAWING
ACCESSORIESROUTERS
/ PLANERS
ACCESSORIESCLEANERS
ACCESSORIESHEAT GUN / LASERS
ACCESSORIESBRAD NAILS/ PINS
STAPLERGARDEN TOOLS
ACCESSORIESHAND TOOLS /
COMBINATION SETS**Abrasive Disc - Pre Punched, Hook & Loop**

For Model: BO6050, BO6040, BO6030

For Stripping the paint

	Grit	Part No.	Pcs per pkg.
 150mm with 15 holes	40	B-51502	10
	60	B-51518	10
	80	B-51524	10
	100	B-51530	10
	120	B-51546	10
	180	B-51552	10
	240	B-51568	10
	320	B-51574	10
	400	B-51580	10

Abrasive Disc for Disc Sander

For model GV6000, GV6010

CC: For stone and plastics

Diameter (mm)	Grit	Part No.	Pcs per pkg.
150	CC50	794086-1	10
150	CC80	794088-7	10
150	CC120	794090-0	10

Pressure sensitive type

For model GV6000, GV6010

Disc type and use**WA:** For wood, iron and steel

Diameter (mm)	Grit	Part No.	Pcs per pkg.
150	WA60	• 794274-0	10
150	WA100	• 794275-8	10
150	WA120	• 794276-6	10
150	WA150	• 794277-4	10
150	WA180	• 794278-2	10

PAD**Rubber pad for Abrasive Disc**

A: For spindle thread 5/8"

B: For spindle thread M14 x 2(DIN), M16 x 2



Outer Diameter (mm)	Type	Part No.
For Model: GV6010 (Pressure sensitive type)		
147	-	743033-9
For Model: 180mm Disc Sander, Polisher, Angle Sander		
170	A	743012-7
For Model: 180mm Disc Sander, Polisher		
170	B	743008-8

Rubber pad (used with Pre-punched Abrasive Disc)

HG: Hard (For coarse grinding)

S: Soft (For general sanding)

SS: Super Soft (For fine sanding)

M: Medium (For general sanding)

H: Hard (For coarse Sanding)

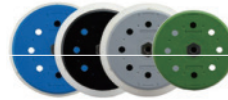

Outer Diameter (mm)	Type	Part No.
---------------------	------	----------

For Model: DSL800

150	S	199939-3
150	M	199940-8
150	H	199938-5

For Model: BO6050

150	H	197315-5
150	S	197314-7
150	SS	197316-3

For Model: BO6030, BO6040

150	HG	196685-9
150	S	196684-1
150	SS	A-87828

For Model: BO5030, BO5041, BO5010, BO5020, BO5021, DBO180

125	-	743081-8
-----	---	-----------------

For Model: PW5001C

100	-	743080-0
-----	---	-----------------

For Model: P06000C / DPO600

150	-	197929-0
-----	---	-----------------

Pad Complete for Abrasive paper

Type A: Standard equipment for BO4900
Type B: Standard equipment for BO4901

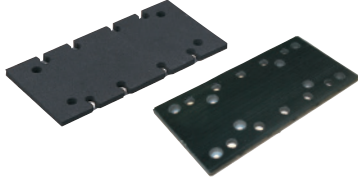

Model	Type	Part No.
BO3700, BO3710	-	140441-9
BO4560	-	150067-9
BO4900, BO4901	A	193521-0
Hook & Loop Type		
BO3700, BO3710	-	194930-6
BO4900, BO4901	B	193523-6

Ruber pad assembly

- Application: Buffing
- Features: Mounts buffing pad to drill
- Allows drill to be used for buffing



Collet Size	Size	Part No.
6mm	98mm	123001-2

Foam polishing pad

- Application: Polishing, glass, metal, paint
- Used on cordless drills with shank for chuck.
- Foam polishing pad 125mm dia for applying wax and polishing compounds



Size	Part No.
125mm dia.	794159-0

Sanding Lock Nut

For Model: 9207SPB, 9227C



Spindle Thread	Outer Dia (mm)	Part No.
M14 x 2DIN	48	224515-5

Adapter for Wool Bonnet Double Side

For Model: PV7001C, PV7000C,
9227C/B, 9237C/B, SA7000C



Size	Part No.
M14	D-56960

Plastic Pad / Washer & Hex Socket head Bolt

For Model: GV6000, GV6010



Size	Part No.
Plastic pad 120	743025-8
Hex Socket head bolt M8 x 20	265812-0
Washer 10	253951-8

Backing Pad (Hook & Loop type)

- Use with Wool pad and Sleeve 18 or Sponge pad



For Model	Spindle Thread	Part No.
9227C/CB, 9237C, SA7000C, PV7000C	M14 x 2(DIN)	743053-3
	5/8"	743052-5

Punch Plate

- Allows for maximum collection of dust and debris from underneath the sander



For Model	Part No.
9036	163292-3
BO4901, 9046	192523-3
BO4556	450066-4
BO3700	192989-7

BATTERY /
CHARGERS

FIXING FASTENING
(SCREWDRIVER BITS
/ IMPACT SOCKETS)

DRILLING
(WOOD / METAL/
MASONRY)

DRILLING
/ DEMOLITION
(CONCRETE)

CUTTING
(METAL)

MULTI TOOL
ACCESSORIES

DIAMOND
(CUTTING / GRINDING)

GRINDING
ACCESSORIES

SANDING
/ POLISHING
ACCESSORIES

SAWING
ACCESSORIES

ROUTERS
/ PLANERS
ACCESSORIES

CLEANERS
ACCESSORIES

HEAT GUN / LASERS
ACCESSORIES

BRAD NAILS/ PINS
STAPLER

GARDEN TOOLS
ACCESSORIES

HAND TOOLS /
COMBINATION SETS

- BATTERY / CHARGERS
- FIXING FASTENING (SCREWDRIVER BITS / IMPACT SOCKETS)
- DRILLING (WOOD / METAL / MASONRY)
- DRILLING / DEMOLITION (CONCRETE)
- CUTTING [METAL]
- MULTI TOOL ACCESSORIES
- DIAMOND [CUTTING / GRINDING]
- GRINDING ACCESSORIES
- SANDING / POLISHING ACCESSORIES
- SAWING ACCESSORIES
- ROUTERS / PLANERS ACCESSORIES
- CLEANERS ACCESSORIES
- HEAT GUN / LASERS ACCESSORIES
- BRAD NAILS/ PINS STAPLER
- GARDEN TOOLS ACCESSORIES
- HAND TOOLS / COMBINATION SETS

Wool Pad (Hook & Loop type)

- For high gloss polishing



* Use with Backing pad and Sleeve 18

For Model	Size (mm)	Part No.
-	100	794173-6
BO5021, BO5041	140	794560-9
BO6030, BO6040, BO6050, PO6000C / DPO600	150	199424-6
9207SPB, 9218PB, SA7000C, PV7000C	180	*192629-7
9237CB, SA7000C, PV7000C	180	P-45135 (thread type)

Sponge Pad (Hook & Loop type)

- For wax coating



For Model	Size (mm)	Part No.
9227C/CB, 9237C, SA7000C, PV7000C	190	193470-1
BO6030, BO6040, BO6050, DPO600, PO6000C	150	197914-3

Felt Pad (Hook & Loop type)

- For removing wax



For Model	Size (mm)	Part No.
BO6030, BO6040, BO6050, DPO600, PO6000C	150	794618-4

Cotton Buff Wheel 120

- For polishing

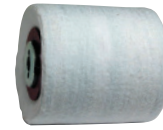

For Model	Part No.
9741	794381-9

Wire brush Wheel 120

- For rust removal



For Model	Part No.
9741	794382-7

Slit Paper Wheel 120-140

- For rust & paint removal



For Model	Part No.
9741	794380-1

Nylon Brush Wheel 120

- To enhance wood grain

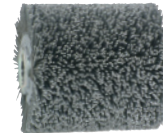

For Model	Use	Part No.
9741	120-80 Coarse	794384-3
	120-100 Medium	794379-6
	120-240 Fine	794383-5

Diamond Polishing Pad (100mm)

- For Model: PW5000C, PW5001C
(Hook & loop type)

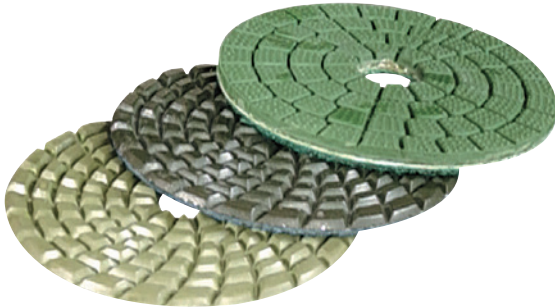

Color	Grit	Max. RPM	Part No.
Blue	50	4,500	D-15584
Yellow	100	4,500	D-15590
Orange	200	4,500	D-15609
Red	400	4,500	D-15615
Dark Green	800	4,500	D-15621
Light Green	1500	4,500	D-15637
Brown	3000	4,500	D-15643
Green	Buff (Finishing)	4,500	D-15659
1 pc. of each polishing pad - 8 pcs set.		4,500	D-15805



Sanding Shoe Assembly

- Allows use of Belt Sander's linear motion and speed control for fine finishing.



For Model	Part No.
9404	193072-3

Clamp Complete

- Provides a secure holding for the sander and a steady work-base for the operator



For Model	Part No.
9910	192694-6



Step

- Mounts sander upside down for easier finishing of smaller pieces



For Model	Part No.
9401	342332-2

BATTERY /
CHARGERSFIXING FASTENING
(SCREWDRIVER BITS
/ IMPACT SOCKETS)DRILLING
(WOOD / METAL/
MASONRY)DRILLING
/ DEMOLITION
(CONCRETE)CUTTING
(METAL)MULTI TOOL
ACCESSORIESDIAMOND
(CUTTING / GRINDING)GRINDING
ACCESSORIESSANDING
/ POLISHING
ACCESSORIESSAWING
ACCESSORIESROUTERS
/ PLANERS
ACCESSORIESCLEANERS
ACCESSORIESHEAT GUN / LASERS
ACCESSORIESBRAD NAILS/ PINS
STAPLERGARDEN TOOLS
ACCESSORIESHAND TOOLS /
COMBINATION SETS

- BATTERY / CHARGERS
- FIXING FASTENING (SCREWDRIVER BITS / IMPACT SOCKETS)
- DRILLING (WOOD / METAL / MASONRY)
- DRILLING / DEMOLITION (CONCRETE)
- CUTTING [METAL]
- MULTI TOOL ACCESSORIES
- DIAMOND [CUTTING / GRINDING]
- GRINDING ACCESSORIES
- SANDING / POLISHING ACCESSORIES
- SAWING ACCESSORIES
- ROUTERS / PLANERS ACCESSORIES
- CLEANERS ACCESSORIES
- HEAT GUN / LASERS ACCESSORIES
- BRAD NAILS/ PINS STAPLER
- GARDEN TOOLS ACCESSORIES
- HAND TOOLS / COMBINATION SETS

Carbon Plate

- Used with Abrasive Belt WA/AA type and Cork Rubber Plate.



For Model	Part No.
9401	423029-3
9403	421648-9
9404	423317-8
9920	423316-0
9920	193198-1

Cork Rubber Plate

- Used with Abrasive Belt WA/AA type and Carbon Plate



For Model	Part No.
9401, 9403	421093-8
9404	423314-4
9920	423313-6

Steel Plate

- Used with: Abrasive Belt CC type
Type A: Includes Cork Rubber Plate.



For Model	Type	Part No.
9401	-	342328-3
9403	A	150980-1
9404	A	151751-9
9900B	-	342466-1
9924DB	-	341705-6

Stand Set

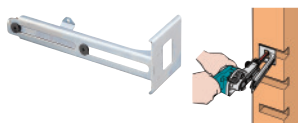

For Model	Part No.
9032, DBS180	193618-5

Sanding Arm Assembly

Type A: Standard equipment for 9032



For Model	Size (mm)	Size (mm)	Part No.
9032, DBS180	6	-	125157-7
	9	A	125158-5
	13	-	125159-3

Belt Sander Stand





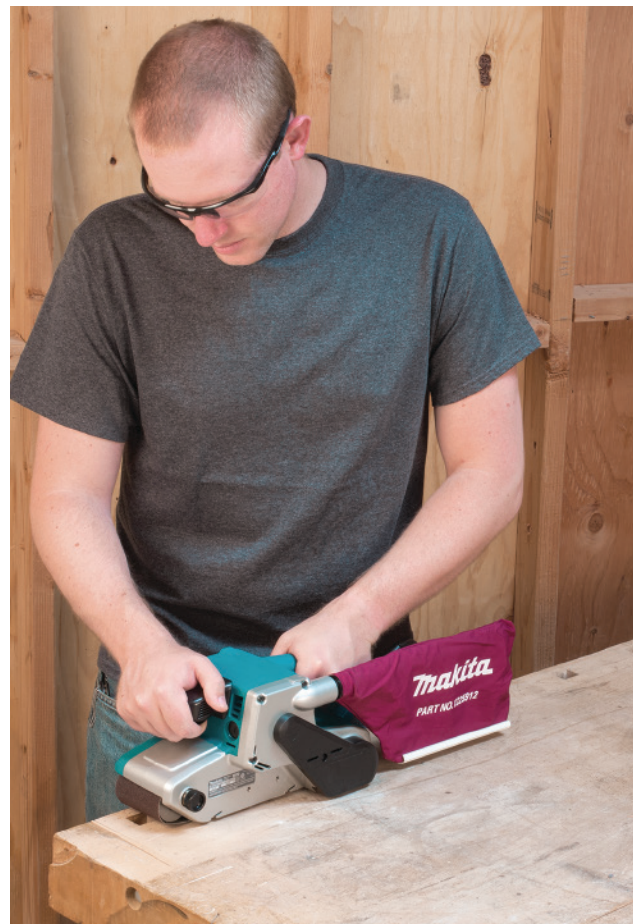









For Model	Part No.
9404, 9902, 9903, 9920	193055-3
9900B, 9924DB	STEX122299



Dust bag assembly

For All Finishing Sanders and Orbit Sanders
(except for BO6050J)

Part No.	
	152456-4
	151780-2
	140115-2
	135246-0 Used with (Plastic)
	Paper dust bag 194746-9 (5pcs set) Sold separately
	166047-5 Used with
	166078-4 Used with
	Nozzles Sold separately 416063-0 + 416064-8
Nozzles are must to connect dust bag with the tools	
	151517-7 Used with
	Nozzle Sold separately 151518-5
Nozzle is must to connect dust bag with the tools	
	193294-5 Used with
	Paper dust bag Sold separately 193526-0 or 193293-7 (5pcs set)
	

Hex Wrench



For Model	Size	Part No.
BO6040/BO6030/GV6010	5	783203-8
9227C/9741	6	783204-6

Dust bag assembly

For Belt Sanders



For Model	Part No.
9032	122297-2
9924DB	122296-4
9903, 9404, 9920	122591-2
9403	122562-9
9910	122548-3

Grip/Loop Handle



Grip



Loop Handle

For Model	Type	Part No.
Disc Sander		
GV6000, GV6010, GV7000C	Grip	152491-2
Polisher and Sander-Polisher		
9218PB, 927SPB	Grip	152492-0
Polisher		
PV7000C	Grip	273649-1
Sander-polisher		
9227C	Grip	153489-2
9227C	Loop Handle	416256-9
9227CB	Loop Handle	416348-4
Angle Sander		
SA7000C, SA7021	Grip	152539-0

Lock Nut Wrench



For Model	Size	Part No.
9218SB/9218PB/GV7000C	28	782423-1
SA7000C/SA7021	35	782407-9
9207SPB	28	782412-6

BATTERY /
CHARGERS

FIXING FASTENING
(SCREWDRIVER BITS
/ IMPACT SOCKETS)

DRILLING
(WOOD / METAL/
MASONRY)

DRILLING
/ DEMOLITION
(CONCRETE)

CUTTING
(METAL)

MULTI TOOL
ACCESSORIES

DIAMOND
(CUTTING / GRINDING)

GRINDING
ACCESSORIES

SANDING
/ POLISHING
ACCESSORIES

SAWING
ACCESSORIES

ROUTERS
/ PLANERS
ACCESSORIES

CLEANERS
ACCESSORIES

HEAT GUN / LASERS
ACCESSORIES

BRAD NAILS/ PINS
STAPLER

GARDEN TOOLS
ACCESSORIES











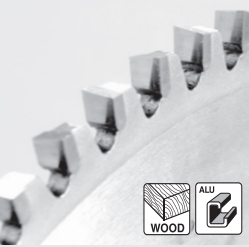





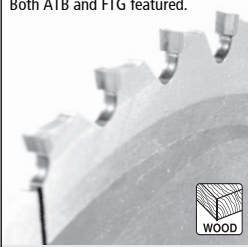

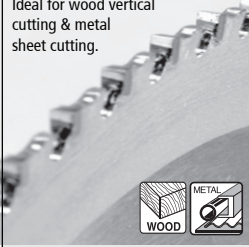

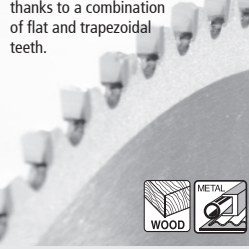
HAND TOOLS /
COMBINATION SETS

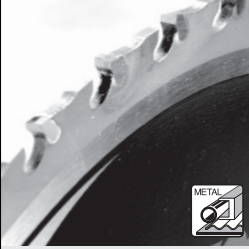
Sawing Accessories



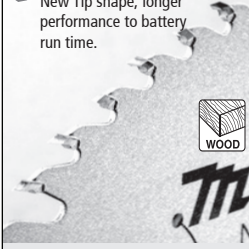

Saw Blades / Jig Saw Blades / Reciprocating Saw Blades



Carbide-tipped saw blade Tooth shape

<p>ATB For wood and Aluminum</p>  <p>WOOD  ALU </p> <p>Good cutting speed</p>	<p>ATAF Angled rake face added to ATB. Good cutting against wood fiber.</p>  <p>WOOD </p> <p>Good cutting speed</p>	<p>ATAFR Flat tip added to ATAF. Cutting straightness improved.</p>  <p>WOOD </p> <p>Good cutting surface</p>	<p>M-FORCE Symmetrical V-shape tip. Both ATB and FTG featured.</p>  <p>WOOD </p> <p>Good cutting surface</p>	<p>FTG Good straightness & durability. Ideal for wood vertical cutting & metal sheet cutting.</p>  <p>WOOD  METAL </p> <p>Good straightness</p>
<p>TCG Easy straight cutting and less tipping thanks to a combination of flat and trapezoidal teeth.</p>  <p>WOOD  METAL </p> <p>long life</p>	<p>MTCG Not easy to lack or break tooth.</p>  <p>METAL </p> <p>Long life</p>	<p>SMTCG Acute angle is added to MTCG, Cutting performance is improved.</p>  <p>WOOD  METAL </p> <p>Long life</p>	<p>Hi-ATB Sharper than ATB</p>  <p>WOOD </p> <p>Good cutting speed</p>	<p>EFFICUT New Tip shape, longer performance to battery run time.</p>  <p>WOOD </p> <p>Speedy, smooth cutting</p>

Technical term

<p>Laser Slit</p>  <p>Vibration dampening system Resinbond filled laser cut body slots for smoother and quieter cuts.</p>	<p>Coated</p>  <p>PTFE (polytetrafluoroethylene) coating plate to reduce pitch build-up and to lower resistance.</p>	<p>Tip Embedded</p>  <p>Inserted tooth design will greatly increase the body-to-tip braze area for greater support and tip strength.</p>	<p>P.C.D Tip</p>  <p>PCD (Poly-Crystalline Diamond) tips has extreme hardness and wear resistance. PCD tipped saw blade is the best choice for long lasting performance when cutting fiber cement board.</p>
---	--	---	--

BATTERY / CHARGERS

FIXING FASTENING (SCREWDRIVER BITS / IMPACT SOCKETS)

DRILLING (WOOD / METAL / MASONRY)

DRILLING / DEMOLITION (CONCRETE)

CUTTING [METAL]

MULTI TOOL ACCESSORIES

DIAMOND [CUTTING / GRINDING]

GRINDING ACCESSORIES

SANDING / POLISHING ACCESSORIES

SAWING ACCESSORIES

ROUTERS / PLANERS ACCESSORIES

CLEANERS ACCESSORIES

HEAT GUN / LASERS ACCESSORIES

BRAD NAILS/ PINS STAPLER

GARDEN TOOLS ACCESSORIES

HAND TOOLS / COMBINATION SETS



EFFICUT

PREMIUM SAW BLADES

SPECIALIZED
FOR CORDLESS SAWS



Makita Corporation
PART No. B-64624
HW 260 x 2.15 x 30mm
n max. 5,870min⁻¹



EFFICIENT SLIM TIP'S BOTTOM
reduces cutting resistance providing a longer runtime

EFFICIENT CURVED TIP'S BODY
allows excellent chip removal with reduced cutting resistance

EFFICIENT SHARP TIP'S TOP ANGLE
provides clear cutting with little effort

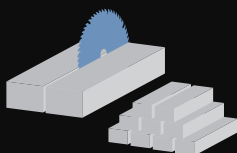

More cuts per charge



Fast cutting



Longer life

Efficut saw blades for Circular Saws



Blade Dia (mm)	(Bore) Hole dia. (mm)	(Kerf) Tip Thickness (mm)	Plate (mm)	No. of teeth	Hook Angle (deg)	Tooth Shape	Application	Part No.
165	20	1.4	1	25	23	ATAFR	Wood	B-63018
165	20	1.45	1	56	23	ATAFR	Wood/MDF	B-57364
185	20	1.45	1	24	23	ATAFR	Wood	B-62022
185	20	1.45	1	45	23	ATAFR	Wood	NEW B-68616
190	20	1.45	1	24	23	ATAFR	Wood	B-64200
190	20	1.45	1	45	23	ATAFR	Wood	NEW B-68644
235	30	2.2	1.5	24	20	ATAFR	Wood	E-01909

BATTERY / CHARGERS

FIXING FASTENING (SCREWDRIVER BITS / IMPACT SOCKETS)

DRILLING (WOOD / METAL / MASONRY)

DRILLING / DEMOLITION (CONCRETE)

CUTTING (METAL)

Efficut saw blades for Slide Compound / Miter Saws



Blade Dia (mm)	(Bore) Hole dia. (mm)	(Kerf) Tip Thickness (mm)	Plate (mm)	No. of teeth	Hook Angle (deg)	Tooth Shape	Application	Part No.
165	20	1.85	1.35	60	10	ATAFR	Wood	NEW B-69892
260	30	2.15	1.65	45	18	ATAFR	Wood	B-64624
260	30	2.15	1.65	60	10	ATAFR	Wood	B-67234
260	30	2.15	1.65	80	10	ATAFR	Wood	B-67240
305	30	2.15	1.65	60	10	ATAFR	Wood	B-67256
305	30	2.15	1.65	80	10	ATAFR	Wood	B-67262
305	30	2.15	1.65	100	10	ATAFR	Wood	B-67278

MULTI TOOL ACCESSORIES

DIAMOND (CUTTING / GRINDING)

GRINDING ACCESSORIES

SANDING / POLISHING ACCESSORIES

Efficut saw blades for Plunge Cut Circular Saw



Blade Dia (mm)	(Bore) Hole dia. (mm)	(Kerf) Tip Thickness (mm)	Plate (mm)	No. of teeth	Hook Angle (deg)	Tooth Shape	Application	Part No.
165	20	1.4	1	25	23	ATAFR	Wood/MDF	B-57364

SAWING ACCESSORIES

ROUTERS / PLANERS ACCESSORIES

Efficut saw blades for Metal Cutter



Designed with the Efficut specific tip shape that allows for increased cutting speed, smoother cuts and more cuts per charge when paired with your Makita cordless metal cutting saws.



STRONG AND LEAST CHIPPING



RELEASE SWARF SMOOTHLY



SUPERIOR IN STRAIGHT CUTTING

MORE CUTS PER CHARGE



FAST CUTTING



LONGER LIFE



CLEANERS ACCESSORIES

HEAT GUN / LASERS ACCESSORIES

BRAD NAILS/ PINS STAPLER

GARDEN TOOLS ACCESSORIES

Blade Dia (mm)	Suitable for Models	(Bore) Hole dia. (mm)	(Kerf) Tip Thickness (mm)	Plate (mm)	Hook Angle (deg)	No. of teeth	Material	Part No.
150	DCS553	20	1.1	0.95	0	33	Metal	B-69440
150	DCS553	20	1.1	0.95	0	48	Metal & SUS	B-69456

HAND TOOLS / COMBINATION SETS

Plunge Cut Saw Blades

Blades Designed specifically for Plunge Type Saws. Available for cutting both wood and aluminium, they are especially designed for a smooth clean cut. Plunge saw blades comes with a patented technology dampening vibration. The low vibration blades run truer with less wobble easily plunging into material with little effort.



Blade Dia (mm)	Suitable for Models	(Bore) Hole dia. (mm)	Ring Size	(Kerf) Tip Thickness (mm)	Plate (mm)	No. of teeth	Tooth Shape	Application	Part No.	
165	DSP600, DSP601, SP6000	20	-	1.85	1.25	8	48	ATB	Wood	B-56166
165	DSP600, DSP601, SP6000	20	-	2.2	1.6	8	48	ATB	Wood	B-09298
165	DSP600, DSP601, SP6000	20	-	2.0	1.4	5	60	TCG	MDF	B-56677
165	DSP600, DSP601, SP6000	20	-	2.0	1.4	-3	56	TCG	Aluminum	B-56655
165	DSP600, DSP601, SP6000	20	-	2.4	1.7	-3	56	TCG	Aluminum	B-09307
165	DSP600, DSP601, SP6000	20	-	2.0	1.4	5	48	TCG	CORIAN®	B-56683

Specialized Circular Saw Blade for Sandwich Panel

Application/ Recommended Use

- Suitable for cutting a sandwich panel
- Ideal for roofing contractors and insulated panel walls.

TRIPLE CHIP GRIND

The modified Triple Chip Grind tooth design prevents premature chipping with harder tungsten for longer life

ANTI-KICK BACK SHOULDER

Tooth design prevents lifting of the material between the metal panels causing kick back

LASER SLOTS

Laser etched and back filled with bonding to reduce vibration and noise



Blade Dia (mm)	Suitable for Models	(Bore) Hole dia. (mm)	Ring Size	(Kerf) Tip Thickness (mm)	Plate (mm)	Hook Angle (deg)	No. of teeth	Tooth hape	Part No.
165	Circular Saws	20	-	1.75	1.4	0	42	SMTCCG	B-63161

Circular Saw Blade (Standard Range)

Application/ Recommended Use

- Cross and rip cutting, Wood, Joinery, Carpentry & Cabinet making.



Blade Dia (mm)	Suitable for Models	(Bore) Hole dia. (mm)	Ring Size	(Kerf) Tip Thickness (mm)	Hook Angle (deg)	No. of teeth	Tooth hape	Application	Part No.
165	5604R / SP6000	20	-	2.0	18	40	ATB	Wood	D-03349
185	5007N, 5800NB, 5806B, 5704RK, HS7010	30	16, 20	2.0	20	16	ATB	Wood	D-03903
185	5007N, 5800NB, 5806B, 5704RK, HS7010	30	16, 20	2.0	20	20	ATB	Wood	D-09634
185	5007N, 5800NB, 5806B, 5704RK, HS7010	30	16, 20	2.0	18	40	ATB	Wood	D-03919
195	5007N, 5704RK, HS7010	25.4	-	2.0	10	80	ATB	Wood	D-16396
235	N5900B	30	25, 25.4	2.4	20	20	ATB	Wood	D-03925
235	N5900B	30	25	2.4	18	48	ATB	Wood	D-03931
235	N5900B	30	25	2.4			ATB	Wood	D-09640

Circular Saw Blade (Mid Range)

Application/ Recommended Use

- Cross and rip cutting, Wood, Joinery, Carpentry & Cabinet making.



Blade Dia (mm)	Suitable for Models	(Bore) Hole dia. (mm)	Ring Size	(Kerf) Tip Thickness (mm)	Hook Angle (deg)	No. of teeth	Tooth Shape	Application	Part No.
85	HS301D	15		1.0	10	20	ATB	Wood	792623-5
85	HS301D	15		0.5	15	50	TCG	Plywood	792299-8
160	DHS680	20		1.6	18	40	ATAF	Wood	A-80612
160	5604R (Note: Can be used with Model SP6000 but not recommendable.)	20	16	2.8	-5	42	TCG	Wood / Metal	A-02624
165		20	-	2.0	20	10	FTG	Wood	B-02917
165		20	-	2.0	23	40	ATB	Wood	A-86044 (Tip Embedded)
180	5800NB	20	-	-	-	-	-	Wood	792041-7
185	5007N / 5806B / 5800N / 5704RK, HS7010	30	20	2.0	25	16	ATB	Wood / Nail	A-86050 (Tip Embedded)
190	5704RK, HS7010	20	-	2.0	20	24	ATAF	Wood	A-87507
235	N5900B	25	-	2.3	20	20	ATB	Wood	A-89947
235	N5900B	30	25	2.3	15	60	ATB	Wood	B-12865
270	-	30	25	2.6	15	60	-	Wood	B-01579
335	5103N	30	25	3.0	20	60	ATB	Wood	B-04248
355	5143R	30		3.0	20	60	ATAF	Wood	A-80014 NEW
415	5402	25	-	2.6	20	60	ATB	Wood	792118-8

BATTERY /
CHARGERS

FIXING FASTENING
(SCREWDRIVER BITS
/ IMPACT SOCKETS)

DRILLING
(WOOD / METAL/
MASONRY)

DRILLING
/ DEMOLITION
(CONCRETE)

CUTTING
(METAL)

MULTI TOOL
ACCESSORIES

DIAMOND
(CUTTING / GRINDING)

GRINDING
ACCESSORIES

SANDING
/ POLISHING
ACCESSORIES

SAWING
ACCESSORIES

ROUTERS
/ PLANERS
ACCESSORIES

CLEANERS
ACCESSORIES

HEAT GUN / LASERS
ACCESSORIES

BRAD NAILS/ PINS
STAPLER

GARDEN TOOLS
ACCESSORIES

HAND TOOLS /
COMBINATION SETS





Slide Compound / Miter Saw Blade

Blade Dia (mm)	Suitable for Models	(Bore) Hole dia. (mm)	Ring Size	(Kerf) Tip Thickness (mm)	Hook Angle (deg)	No. of teeth	Tooth Shape		Part No.
165	DSL600	20	-	1.9	10	64	ATAF	Wood	B-56487
165	DSL600	20	-	1.8	5	60	TCG	Aluminium	B-56530
190	DLS713 / DLS714	20	-	2.0	10	72	ATAF	Wood	A-86359
210	-	25	-	2.0	8	80	ATB	Wood	792438-0
216	LS0815FL	30	-	2.4	5	48	ATB	Wood	B-39506
216	LS0815FL	30	-	2.2	-5	30	TCG	Aluminium	B-09628
255	LS1040, LS1016, LS1019L, LS1018L, LH1040, LF1000	30	15.88	2.3	5	32	-	Wood	A-80961 (Tip Embedded)
255	LS1040, LS1016, LS1019L, LS1018L, LH1040, LF1000	15.88	-	2.8	-	48	-	Wood	792200-3
255	LF1000, LS1040, LH1040, LS1013	25	-	2.4	15	60	-	Wood	B-01591
260	LS1040, LS1019L, LS1018L, LH1040, LF1000, DLS111	30	15.88	2.3	5	40	-	Wood	B-03545
260	LS1040, LS1019L, LS1018L, LH1040, LF1000, DLS111	30	15.88	2.3	5	60	-	Wood	B-03486
260	LS1040, LS1019L, LS1018L, LH1040, LF1000, DLS111	30	15.88	2.3	5	60	-	Wood	B-11019
260	LS1040, LS1019L, LS1018L, LH1040, LF1000, DLS111	30	15.88	2.3	5	70	-	Wood	B-04597
260	LS1040, LS1019L, LS1018L, LH1040, LF1000, DLS111	30	15.88	2.3	5	80	-	Wood	B-03551
260	LS1040, LS1019L, LS1018L, LH1040, LF1000, DLS111	30	15.88	2.3	5	100	-	Wood	B-03567
260	LS1040, LH1040, LF1000, DLS211	30	25	2.6	15	60	-	Wood	B-01563
305	LS1214, LS1216, LS1219L, DLS211	25.4	Use with Ring 257060-5	2.3	5	60	ATAF	Wood	B-02808
305	LS1214, LS1216, LS1219L, DLS211	25.4	Use with Ring 257060-5	2.3	5	96	ATAF	Wood	B-02814
305	LS1214, LS1216, LS1219L, DLS211	30	15.88	2.3	5	60	-	Wood	B-03589
305	LS1214, LS1216, LS1219L, DLS211	30	15.88	2.3	5	80	-	Wood	B-03595
305	LS1214, LS1216, LS1219L, DLS211	30	15.88	2.3	5	100	-	Wood	B-03604
355	LS1440	25	-	3.0	20	60	ATB	Wood	A-02618
355	LS1440	30	-	3.0	5	80	-	Wood	B-04282
380	-	25	-	2.6	10	50	-	Wood	A-05795
380	-	25	-	3.0	10	100	-	Wood	A-01943

Table Saw Blade

Blade Dia (mm)	Suitable for Models	(Bore) Hole dia. (mm)	Ring Size	(Kerf) Tip Thickness (mm)	Hook Angle (deg)	No. of teeth	Tooth Shape		Part No.
210	2702 (Not suitable for 2703/2704)	30	25.4	1.9	25	18	-	Wood	A-81767 (Tip Embedded)
255	2703, 2704	25.4	-	2.3	20	24	ATB	Wood	B-05000
260	2703, 2704	30	-	2.3	20	24	-	Wood	B-04999
315	2712	30	-	2.8	9	40	-	Wood	JM27170005

Thin Kerf

- Fast Cut / Fine Finish
- Thin kerf for less waste and reduced feed pressure.
- Application: Cross and rip cutting. Wood. Joinery, Carpentry & Cabinet making.

Blade Dia (mm)	Suitable for Models	(Bore) Hole dia. (mm)	Ring Size	(Kerf) Tip Thickness (mm)	Hook Angle (deg)	No. of teeth	Tooth Shape		Part No.
160	DSS610, DHS780	20	-	1.6	18	40	ATAF		A-80612
185	5007N, 5806B, 5800NB, HS7010	20	-	1.6	18	40	-		A-80628

Specialized Blade for Construction

Embedded tip for wood with nails (For Construction)

- Can easily cut through wood embedded with nails and screws
- Extremely tough and hard wearing
- Extended service life and productivity



Blade Dia (mm)	Suitable for Models	(Bore) Hole dia. (mm)	(Kerf) Tip Thickness (mm)	Plate Thickness (mm)	Hook Angle (deg)	No. of teeth	Pcs/ Pkg	Part No.
235	N5900B	30	2.6	1.6	20	16	1	B-27274

BATTERY /
CHARGERSFIXING FASTENING
(SCREWDRIVER BITS
/ IMPACT SOCKETS)DRILLING
(WOOD / METAL/
MASONRY)DRILLING
/ DEMOLITION
(CONCRETE)CUTTING
(METAL)MULTI TOOL
ACCESSORIESDIAMOND
(CUTTING / GRINDING)GRINDING
ACCESSORIESSANDING
/ POLISHING
ACCESSORIESSAWING
ACCESSORIESROUTERS
/ PLANERS
ACCESSORIESCLEANERS
ACCESSORIESHEAT GUN / LASERS
ACCESSORIESBRAD NAILS/ PINS
STAPLERGARDEN TOOLS
ACCESSORIESHAND TOOLS /
COMBINATION SETS

'M' Force Blade (Advanced Tooth Design)

A revolutionary advanced tooth design that sets a new bench mark for blade technology. The dual bevelled tooth face has sharper cutting edges and the "M" shape is like doubling the tooth count per blade. A greater wear area and more cutting surfaces means the MForce blade will last up to 2 x longer than traditional blades. A narrow kerf and plate reduces friction allowing for a lighter feed pressure, protecting the motor of your saw.

- Superior cutting surface with less number of teeth.
- Ideal for straight cutting.
- Longer lasting.
- Tooth Type/Set: M Force Blades



Cleaner

'M' shaped 24 tooth has 2 cutting tips that work like a 48 tooth blade!

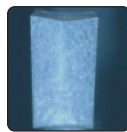

Faster

Bevel tooth face creates sharper edges for an aggressive cut!

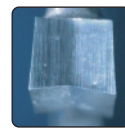

Lasts longer

Greater wear area and more cutting tips increase the life of the blade by 2x!

Application/ Recommended Use

Wood, Non Ferrous material, Plastics, Aluminum, Insulation material, etc.

Blade Dia (mm)	Suitable for Models	(Bore) Hole dia. (mm)	Ring Size	(Kerf) Tip Thickness (mm)	Hook Angle (deg)	No. of teeth	Tooth Shape	Part No.
185	5007N, 5806B, 5800NB, HS7010	30	16, 20	2.0	15	16	M-FORCE	A-89648
185	5007N, 5806B, 5800NB, HS7010	30	16, 20	2.0	15	24	M-FORCE	A-89654
235	N5900B	30	15.88 / 25	2.3	15	20	M-FORCE	B-04117
235	N5900B	30	15.88 / 25	2.3	15	40	M-FORCE	B-04123

Specialized for Cutting (MDF) Medium Density Fiber board

- Specially suited for medium density fibre Boards (MDF)

Type A: Suitable for Circular Saw

Type B: Suitable for Slide Compound Saw / Miter Saw

Blade Dia (mm)	(Bore) Hole dia. (mm)	Ring Size	(Kerf) Tip Thickness (mm)	Hook Angle (deg)	No. of teeth	Tooth Shape	Type	Part No.
185	30	16, 20	2.4	12	60	TCG	A	D-17902
235	30	25	2.8	12	80	TCG	A	D-17918
254	30	15.88	3.2	10	100	TCG	B	D-19071
305	30	15.88	3.2	10	120	TCG	B	D-19087

- BATTERY / CHARGERS
- FIXING FASTENING (SCREWDRIVER BITS / IMPACT SOCKETS)
- DRILLING (WOOD / METAL / MASONRY)
- DRILLING / DEMOLITION (CONCRETE)
- CUTTING [METAL]
- MULTI TOOL ACCESSORIES
- DIAMOND (CUTTING / GRINDING)
- GRINDING ACCESSORIES
- SANDING / POLISHING ACCESSORIES
- SAWING ACCESSORIES
- ROUTERS / PLANERS ACCESSORIES
- CLEANERS ACCESSORIES
- HEAT GUN / LASERS ACCESSORIES
- BRAD NAILS/ PINS STAPLER
- GARDEN TOOLS ACCESSORIES
- HAND TOOLS / COMBINATION SETS

Specialized Blades for Aluminium

Blade Dia (mm)	Suitable for Models	(Bore) Hole dia. (mm)	Ring Size	(Kerf) Tip Thickness (mm)	Hook Angle (deg)	No. of teeth	Tooth Shape	Part No.
260	LS1040, LS1016, LS1018L, LS1013, LH1040, LF1000	30	15.88	2.3	-5	80	-	B-04151
260	LS1040, LS1016, LS1018L, LS1013, LH1040, LF1000	30	15.88	2.3	-5	100	-	B-04167
305	LS1214, LS1216	30	15.88	2.3	-5	80	-	B-04173
305	LS1214, LS1216	30	15.88	2.3	-5	100	-	B-04189
355	LS1440	30	25	3.0	-5	120	-	B-12522

Universal Blade for Cutting Aluminium

Blade Dia (mm)	Suitable for Models	(Bore) Hole dia. (mm)	Ring Size	(Kerf) Tip Thickness (mm)	Hook Angle (deg)	No. of teeth	Tooth Shape	Part No.
210	-	30	25	2.8	-5	54	-	A-02646
285	LS1040, LS1016, LS1018L, LS1013, LH1040, LF1000	30	25	3.2	-5	80	-	A-02668

T.C.T Wood Cutting Saw Blade for 4100NH Cutter

Model 4100NH is a powerful cutter machine for cutting in stone, masonry, tile, concrete. Now Makita developed new T.C.T wood cutting saw blade for cutter 4100NH which make this machine more versatile.



SPECIALIZED
for wood cutting



Blade Dia (mm)	Suitable for Models	(Bore) Hole dia. (mm)	(Kerf) Tip Thickness (mm)	Plate Thickness (mm)	No. of teeth	Tooth Shape	Part No.
100	4100NH	20	1.6	1.0	30	-	B-39475

Saw Blade Depth Adjustment

Saw blade depth adjustment is critical for good performance and operator safety. i.e reduce the risk of limb injury while holding the work piece for example. The lower the angle the smoother & faster the cut

@ 30 degree

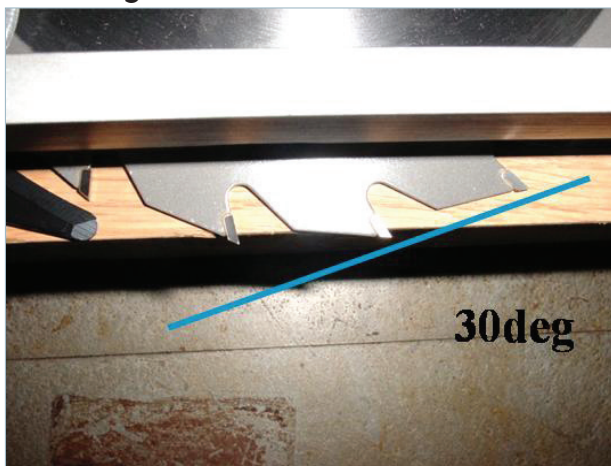

Two cutting-tips are engaged in a "shaving" position allowing the tooth to cut at a 30 degree angle

@ 60 degree

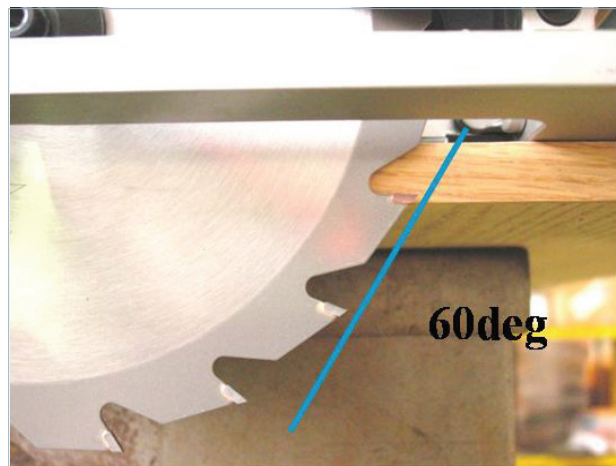

Only one cutting tip is engaged in a "chopping" position forcing the tooth to cut at a 60 degree angle.

Combination Saw Blade (H.S.S)

Application/ Recommended Use: For rip and cross-cut work. Has fewer teeth than cross cut blade for faster cutting.

Blade Dia (mm)	(Bore) Hole dia. (mm)	(Kerf) Tip Thickness (mm)	No. of Teeth	Part No.
110	20	0.9	50	792010-8
180	20	1.2	80	792031-0
185	20	1.25	50	792495-8
255	25	1.45	52	792423-3
260	25	1.25	52	792083-1

Cross Cut Saw Blade (H.S.S)

Application/ Recommended Use: For smoother cross-grain cuts in wood. Make smoother cuts than combination blade.

Type A: Miter saw blade for Wood

Blade Dia (mm)	(Bore) Hole dia. (mm)	(Kerf) Tip Thickness (mm)	No. of Teeth	Type	Part No.
110	20	-	60	-	792012-4
160	20	1.0	100	-	792021-3
255	25	-	100	A	792077-6
255	15.88	-	50	-	792640-5
260	25	-	80	-	792084-9
355	25	-	70	-	792699-2
415	25	-	100	-	792115-4

Wave Saw Blade

Application/ Recommended Use: For cutting 6mm or thinner aluminium, copper or other soft metals, must use lubricant.

Blade Dia (mm)	(Bore) Hole dia. (mm)	(Kerf) Tip Thickness (mm)	No. of Teeth	Part No.
152	20	1.2	50	792019-0

Rip Saw Blade

Application/ Recommended Use: For faster cutting with grain.

Similar to combination blade teeth in shape but larger in size for better chip clearance and less binding.

Blade Dia (mm)	(Bore) Hole dia. (mm)	(Kerf) Tip Thickness (mm)	No. of Teeth	Part No.
415	25	-	70	792114-6

BATTERY /
CHARGERS

FIXING FASTENING
(SCREWDRIVER BITS
/ IMPACT SOCKETS)

DRILLING
(WOOD / METAL/
MASONRY)

DRILLING
/ DEMOLITION
(CONCRETE)

CUTTING
(METAL)

MULTI TOOL
ACCESSORIES

DIAMOND
(CUTTING / GRINDING)

GRINDING
ACCESSORIES

SANDING
/ POLISHING
ACCESSORIES

SAWING
ACCESSORIES

ROUTERS
/ PLANERS
ACCESSORIES

CLEANERS
ACCESSORIES

HEAT GUN / LASERS
ACCESSORIES

BRAD NAILS/ PINS
STAPLER

GARDEN TOOLS
ACCESSORIES

HAND TOOLS /
COMBINATION SETS

BATTERY / CHARGERS

FIXING FASTENING (SCREWDRIVER BITS / IMPACT SOCKETS)

DRILLING (WOOD / METAL/ MASONRY)

DRILLING / DEMOLITION (CONCRETE)

CUTTING [METAL]

MULTI TOOL ACCESSORIES

DIAMOND [CUTTING / GRINDING]

GRINDING ACCESSORIES

SANDING / POLISHING ACCESSORIES

SAWING ACCESSORIES

ROUTERS / PLANERS ACCESSORIES

CLEANERS ACCESSORIES

HEAT GUN / LASERS ACCESSORIES

BRAD NAILS/ PINS STAPLER

GARDEN TOOLS ACCESSORIES

HAND TOOLS / COMBINATION SETS

Chisel Tooth Combination Saw blade (H.S.S)

Application/ Recommended Use For rip and cross-cut work. Most frequently used for general carpentry.

Blade Dia (mm)	(Bore) Hole dia. (mm)	(Kerf) Tip Thickness (mm)	No. of teeth	Part No.
203	25	1.35	32	792066-1
235	25	1.5	30	792070-0
255	15.88	1.6	36	792317-2
260	25	1.4	36	792087-3
335	25	2.1	40	792099-6
380	25	1.65	46	792109-9
380	25	1.85	46	792263-9
415	25	1.65	50	792116-2

Ring

(for 5/8" = 15.88 mm spindle)

Outer Dia (mm)	(Bore) Hole dia. (mm)	(Kerf) Tip Thickness (mm)	Pcs / Pkg	Part No.
25	15.88	4.0	1	257022-3
25.4	15.88	4.0	1	257060-5
30	15.88	3.0	10	A-87270

Specialized Saw Blade for Metal Cutter



DCS553 (DC)



4131 (AC)



A: Cermet tip type (Ceramic / Metal), Long Life

Blade Dia (mm)	Suitable for Models	(Bore) Hole dia. (mm)	(Kerf) Tip Thickness (mm)	Hook Angle (deg)	No. of teeth	Tooth Shape	Material / Application	Type	Part No.
136	DCS550	20	1.5	0	30	MTCG	Mild steel	-	B-07319
150	DCS553	20	1.5	0	32	MTCG	Mild steel	-	B-46296
150	DCS553	20	1.1	0	60	SMTCG	Stainless/Mild steel	Laser Slit	B-47014
185	4131	20	1.9	0	36	ATB	Mild steel (2 - 6mm)	A	B-04628
185	4131	20	2.0	0	48	MTCG	Thin mild steel (2 - 4mm)	-	A-83967
185	4131	20	1.7	-10	70	FTG	Corrugated thin plate (Less than 2mm)	-	A-86446

Specialized Saw Blade for Portable Cut-Off



LC1230 (AC)



Blade Dia (mm)	Suitable for Models	(Bore) Hole dia. (mm)	(Kerf) Tip Thickness (mm)	Hook Angle (deg)	No. of teeth	Tooth Shape	Material / Application	Type	Part No.
305	LC1230	25.4	2.4	0	60	TCG	For cutting mild steel	Laser slit	A-86723
305	LC1230	25.4	2.4	0	78	MTCG	For thinner mild steel	-	A-87127
305	LC1230	25.4	2.3	0	76	-	For stainless steel	-	A-87579
305	LC1230	25.4	2.1	0	60	TCG	For mild steel	-	A-87242

Jig Saw Blade Teeth Type

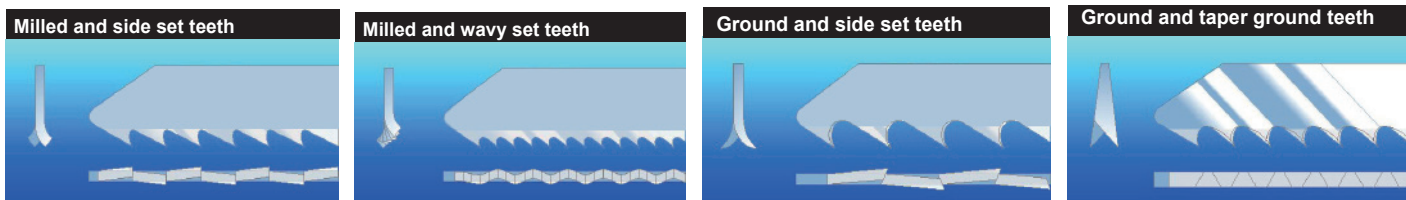

Teeth manufacture



Milled teeth

- Low cost type of manufacturing
- For general cutting
- Soft to hard materials
- Long blade life

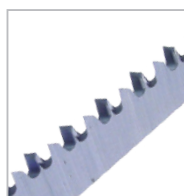

Ground teeth

- Costly type of manufacturing
- Very sharp
- Accurate, clean cut
- Soft to medium hard materials

Production method

Side set: Each individual tooth is alternately bend to the left and to the right. Raker setting example: right, left, straight, etc. 

Wavy set: Row of teeth receives a wave shape

Ground: Blade body tapers to the rear (conical)

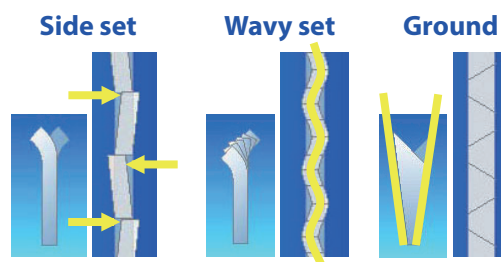

Jig Saw Blade material

Most of our jigsaw blades are manufactured using top quality Japanese steel and are available to cover a very broad spectrum of applications in wood and metal.

- **HCS (High Carbon Steel):** For cutting softer materials such as wood or plastics.
- **HSS (High Speed Steel):** For cutting harder materials such as metals.
- **BiM (Bi-metal, HCS base and HSS teeth):** For cutting soft materials to hard materials such as wood, metal, plastics.
- **TC (Tungsten Carbide):** For cutting glass fiber reinforced plastic, cement-bonded fiberboards or plasterboard.





- BATTERY / CHARGERS
- FIXING FASTENING (SCREWDRIVER BITS / IMPACT SOCKETS)
- DRILLING (WOOD / METAL / MASONRY)
- DRILLING / DEMOLITION [CONCRETE]
- CUTTING [METAL]
- MULTI TOOL ACCESSORIES
- DIAMOND [CUTTING / GRINDING]
- GRINDING ACCESSORIES
- SANDING / POLISHING ACCESSORIES
- SAWING ACCESSORIES
- ROUTERS / PLANERS ACCESSORIES
- CLEANERS ACCESSORIES
- HEAT GUN / LASERS ACCESSORIES
- BRAD NAILS / PINS STAPLER
- GARDEN TOOLS ACCESSORIES
- HAND TOOLS / COMBINATION SETS

Makita Type Jig Saw Blade for Wood



For Model: 4300BA/BV, 4326M, 4327M

Shape	No	Wood Plywood (mm)	Plastics (mm)	Aluminum (mm)	Stainless Steel (mm)	Mild Steel (mm)	Features / Application	Working Length (mm)	Tooth Per Inch	Material	Type of cutting Per pkg.	Part No.
-------	----	-------------------	---------------	---------------	----------------------	-----------------	------------------------	---------------------	----------------	----------	--------------------------	----------









WOOD / BASIC

	3	3-50	3-50				For general cutting of wood & plastics	60	9	HCS		5	A-85868
	16	3-50	3-50				For scroll cutting of wood & plastics	60	9	HCS		5	A-85830



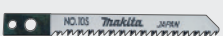



WOOD / FAST

	8	4-50	4-50				For fast cutting of wood & plastics	60	8	HCS		5	A-85911
												2	792267-1



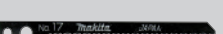

WOOD / FINISH

	9	4-50	4-50				For fast finish work in wood & plastics	60	9	HCS		5	A-85927
	10	4-50	4-50				For fast finish work especially in plywood	60	9	HCS		5	A-85818
	10S	3-50					Splinter-free cuts in wood requiring no sanding	62	13	HCS		5	A-85824
	BR-3	4-50					Splinter-free cuts in wood requiring no sanding	60	9	HCS		5	A-85933

HARDWOOD / DECORATIVE VENEERS

	2	3-50	3-50	2-6	2-6		For decorative veneers	60	14	HSS		5	A-85852
	4	3-50	3-50	3-6	3-6		For hardwood, thick mild steel plate and tough plastic	62	9	HSS		5	A-85874
	17	2-50	2-50	2-6	2-6		Ideal for scroll cutting of decorative veneers	63	14	HSS		5	A-85846





FINISH FOR DECORATIVE VENEERS

	41	3-50	3-50				For tough plastics & decorative veneers finishing (Splinter-free downward cutting teeth)	60	12	HSS		5	A-85880
	42	2-50	2-50				For decorative veneers	60	16	HSS		5	A-85896

Makita Type Jig Saw Blade for Metal

For Model: 4300BA/BV, 4326M, 4327M

METAL / BASIC



	1		1-6	1-3	0.5-3	1-3	For mild steel, stainless steel. Also for corrugated & tough plastics.	60	24	HSS		5	A-85802
	5		2-50				For mild steel	42	24	HSS		5	A-85905

B Type Jig Saw Blade (Universal Blade) for Wood



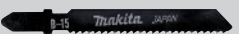
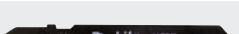

- Fits Makita and most common Jig Saws.
- For Model: DJV180, JV100D, JV101D, JV102D, JV103D, JV183D, DJR185, JR105D, 4326, 4327, 4329, 4350CT/FCT, 4351FCT, JR1000FT

Shape	No	Wood Plywood (mm)	Plastics (mm)	Aluminum (mm)	Stainless Steel (mm)	Mild Steel (mm)	Features / Application	Working Length (mm)	Tooth Per Inch	Material	Type of cutting Per plg.	Part No.
-------	----	-------------------	---------------	---------------	----------------------	-----------------	------------------------	---------------------	----------------	----------	--------------------------	----------





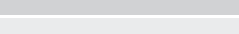

WOOD / BASIC

	B-13	4-65	4-65				For general cutting of wood & plastic	70	8	HCS	↑	5	A-85656
	B-15	3-35	3-35				Ideal for cutting thin materials	50	12	HCS	↑	5	A-85678
	B-14	2-35	2-35				Ideal for cutting thin materials	50	18	HCS	↑	5	A-85662
	B-18	2-35	2-35				Ideal for scroll cutting of wood & plastic	45	14	HCS	↑	5	A-85709

WOOD / FAST

	B-13	4-65	4-65				For fast cutting of wood & plastic	70	8	HCS	↑	5	A-86577
	B-16	5-65	5-65				For fast cutting of wood & plastic	50	6	HCS	↑	5	A-85684
	L-2	5-90	5-90				Ideal for fast cutting of thick materials	100	6	HCS	↑	5	A-86309
	B-17	5-60	5-60				Ideal for scroll cutting of wood & plastic (Fast cutting)	70	6	HCS	↑	5	A-85690
	B-8	4-65	4-65				Ideal for fast cutting of wood & plastic. Hook angle 2°	75	8	HCS	↑	5	A-85232

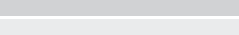

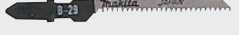
WOOD / FINISH

	B-9	4-65	4-65				For fast finish work in wood & plastic	75	8	HCS	↑	5	A-86583
	B-10	3-65	3-65				For fast finish work especially in plywood	75	9	HCS	↑	5	A-85628
	B-11	3-60	3-60				For fast finish work in wood & plastic	75	9	HCS	↑	5	A-85634
	B-10S	3-50					Splinter-free cuts in wood requiring no sanding	65	13	HCS	↑	5	792691-8
	B-12	5-65	5-65				For fast finish work in wood & plastic	75	6	HCS	↑	5	A-85640
	L-1	5-90	5-90				For fast finish work in of wood & plastic	100	6	HCS	↑	5	A-86290
	B-29	2-35	2-35				Ideal for scroll cutting of wood & plastic (Finishing)	42	16	HCS	↻	5	A-80400
	BR-13	5-65					Splinter-free cuts in wood requiring no sanding.	64	9	HCS	↑	5	A-85793

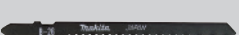
HARDWOOD / DECORATIVE VENEERS

	B-25	3-60	3-6			3-6	For hardwood, thick mild steel plate & tough plastic	75	9	HSS	↑	5	A-85765
	B-26	3-60	3-10			3-10	For scroll cutting in hard woods & in tough plastic	70	9	HSS	↻	5	A-85771

FINISH FOR DECORATIVE VENEERS

	B-15	3-50	3-50				For tough plastic & decorative veneer finishing. (Splinter free downward cutting teeth)	65	12	HCS	↑	5	A-85715
	B-28	2-50	2-50				For decorative veneers	63	16	HSS	↑	5	A-80391

BATTERY / CHARGERS

FIXING FASTENING (SCREWDRIVER BITS / IMPACT SOCKETS)

DRILLING (WOOD / METAL / MASONRY)

DRILLING / DEMOLITION (CONCRETE)

CUTTING (METAL)

MULTI TOOL ACCESSORIES

DIAMOND (CUTTING / GRINDING)

GRINDING ACCESSORIES

SANDING / POLISHING ACCESSORIES

SAWING ACCESSORIES

ROUTERS / PLANERS ACCESSORIES

CLEANERS ACCESSORIES

HEAT GUN / LASERS ACCESSORIES



BRAD NAILS / PINS STAPLER

GARDEN TOOLS ACCESSORIES









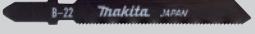

HAND TOOLS / COMBINATION SETS

B Type Jig Saw Blade for Stainless Steel

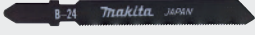









- Specially designed and hardened with TC metal for cutting stainless steel.
- Longer life than standard jigsaw blades
- Capable of making a 3m cut in 1.5mm of stainless steel.

Shape	No.	Wood Plywood (mm)	Plastics (mm)	Aluminium (mm)	Stainless Steel (mm)	Mild Steel (mm)	Features / Application	Working Length (mm)	Tooth Per Inch	Material	Type of cutting	Per pkg.	Part No.
	P-05929				1-2, 5	1-5	For Stainless Steel	50	12	HM		1	P-05929

B Type Jig Saw Blade for Metal

Shape	No.	Wood Plywood (mm)	Plastics (mm)	Aluminium (mm)	Stainless Steel (mm)	Mild Steel (mm)	Features / Application	Working Length (mm)	Tooth Per Inch	Material	Type of cutting	Per pkg.	Part No.
	B-51		1.5-6	1.5-6	1-3	1-3	For mild steel	65	24	HSS		5	A-86561
	B-22		1-6	1-3	1-3	1-3	For mild steel, stainless steel. Also for tough plastics	50	24	HSS		5	A-85737
	B-24		1-3	1-2	0.5-2	0.5-2	For thin mild steel, stainless steel	50	32	HSS		5	A-85759
	B-23	3-35	3-35	2-6		2-6	For decorative veneers	50	14	HSS		5	A-85743
	B-27		1-6	1-3	1-3	1-3	For scroll cutting in mild steel	50	24	HSS		5	A-85787

B Type Jig Saw Blade Universal Fitting (Specialized)

Shape	No.	Wood Plywood (mm)	Plastics (mm)	Aluminium (mm)	Stainless Steel (mm)	Mild Steel (mm)	Features / Application	Working Length (mm)	Tooth Per Inch	Material	Type of cutting	Per pkg.	Part No.
PLASTIC													
	B-21		3-60	1-10			For plastics finish work and tough plastics and aluminium	75	12	HSS		5	A-85721
RUBBER													
	B-K						Ideal for cutting of paper, cork, rubber and leather	75		HCS		5	A-80416
THICK MATERIAL													
	L-10	5-135	5-135				Ideal for cutting thick materials.	150	6	HCS		5	A-86315
FIBER GLASS													
		6-80					Ideal for cutting fiberglass, reinforced plastic etc.	75	6	HM		3	P-38766
		6-80					Ideal for cutting fiberglass, reinforced plastic etc.	105	6	HM		3	P-38772

- BATTERY / CHARGERS
- FIXING FASTENING (SCREWDRIVER BITS / IMPACT SOCKETS)
- DRILLING (WOOD / METAL / MASONRY)
- DRILLING / DEMOLITION (CONCRETE)
- CUTTING [METAL]
- MULTI TOOL ACCESSORIES
- DIAMOND [CUTTING / GRINDING]
- GRINDING ACCESSORIES
- SANDING / POLISHING ACCESSORIES
- SAWING ACCESSORIES
- ROUTERS / PLANERS ACCESSORIES
- CLEANERS ACCESSORIES
- HEAT GUN / LASERS ACCESSORIES
- BRAD NAILS/ PINS STAPLER
- GARDEN TOOLS ACCESSORIES
- HAND TOOLS / COMBINATION SETS

B Type Jig Saw Blade Universal Fitting - Super Express



These blades are a 'Bayonet fit', and can be used with most models of jigsaws.

- For Model: DJV180, JV100D, JV101D, JV102D, JV103D, JV183D, DJR185, JR105D, 4326, 4327, 4329, 4350CT/FCT, 4351FCT, JR1000FT

Shape	No	Wood Plywood (mm)	Plastics (mm)	Aluminium (mm)	Stainless Steel (mm)	Mild Steel (mm)	Features / Application	Working Length (mm)	Tooth Per Inch	Material	Type of cutting	Per pkg.	Part No.
	B-50	5-50	5-50	-	-	-	For a quick cut in wood, with a fine finish	77	8.5-10.6	HCS	↑	5	B-06460
	B-51				1-3	1-8	For metal, 30% faster than our current blades	77	9.8-18.1	HSS	↑	5	B-06476
	B-52	5-50	5-50	3-35	3-5	3-8	For material combinations, like sandwich boards	77	5.5-9.8	HSS	↑	5	B-06482

BATTERY / CHARGERS

FIXING FASTENING (SCREWDRIVER BITS / IMPACT SOCKETS)

DRILLING (WOOD / METAL / MASONRY)

DRILLING / DEMOLITION (CONCRETE)

Jig Saw Blade assortment

These blades are a 'Bayonet fit', and can be used with most models of jigsaws.

- For Model: DJV180, JV100D, JV101D, JV102D, JV103D, JV183D, DJR185, JR105D, 4326, 4327, 4329, 4350CT/FCT, 4351FCT, JR1000FT

Type	No	Application	Package	Part No.
	No.1 No.2 No.3 No.8 10S	-	5 different jig saw blades in one single pack	A-86882
	B-10S B-13 B-16 B-22 B-23	-	5 different jig saw blades in one single pack	A-86898
	B-50 B-51 B-52	-	3 different jig saw blades in one single pack	B-06292
	BR-13	Wood	100pcs in one single box	B-07777

CUTTING (METAL)

MULTI TOOL ACCESSORIES

DIAMOND (CUTTING / GRINDING)

GRINDING ACCESSORIES

Jig Saw Blades (Standard Range) - D-series

The blades are with T-Shank and suitable for use with any Makita or other brand Jigsaw machines which have T shank connection.



Shape	No	Wood Plywood (mm)	Plastics (mm)	Aluminium (mm)	Stainless Steel (mm)	Mild Steel (mm)	Features / Application	Working Length (mm)	Tooth Per Inch	Material	Type of cutting	Per pkg.	Part No.
	4-50						Wood / Basic (Equivalent to B-13)	74	8	HCS	↑	5	D-34877
	4-50						Wood / Fast (Equivalent to B-16)	50	6	HCS	↑	5	D-34883
					1-3		Metal / Basic (Equivalent to B-22)	51	21	HSS	↑	5	D-34908
	4-50						Wood / Finish (Equivalent to B-10)	74	9	HCS	↑	5	D-44214

SANDING / POLISHING ACCESSORIES

SAWING ACCESSORIES

ROUTERS / PLANERS ACCESSORIES

CLEANERS ACCESSORIES

Sanding and Filing for Jig Saw

Shape	Applications (mm)	Features / Recommended Use	Overall Length (mm)	Working Length (mm)	Pc Per Pkg	Part No.
	Wood	Sanding adapter (Use with Abrasive paper)	153	90	1	A-40967
	Wood	Abrasive paper #60 (Use with Sanding adapter)	-	95x22	10	A-40973 B-04977
	Wood	Abrasive paper #120 (Use with Sanding adapter)	-	95x22	10	B-04983
	Metal	File (Round Type)	153	60	3	A-40945
	Metal	File (Flat Type)	153	60	3	A-40951

HEAT GUN / LASERS ACCESSORIES

BRAD NAILS/ PINS STAPLER

GARDEN TOOLS ACCESSORIES

HAND TOOLS / COMBINATION SETS

BATTERY / CHARGERS

FIXING FASTENING (SCREWDRIVER BITS / IMPACT SOCKETS)

DRILLING (WOOD / METAL / MASONRY)

DRILLING / DEMOLITION (CONCRETE)

CUTTING [METAL]

MULTI TOOL ACCESSORIES

DIAMOND (CUTTING / GRINDING)

GRINDING ACCESSORIES

SANDING / POLISHING ACCESSORIES

SAWING ACCESSORIES

ROUTERS / PLANERS ACCESSORIES

CLEANERS ACCESSORIES







HEAT GUN / LASERS ACCESSORIES

BRAD NAILS/ PINS STAPLER

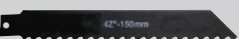

GARDEN TOOLS ACCESSORIES

HAND TOOLS / COMBINATION SETS



Recipro Saw Blade for Wood

Type	No	Teeth per inch	Overall length (mm)	Application	Tooth Material	Per pkg.	Part No.
WOOD / BASIC							
	No.23	9	165	For wood 5mm - 90mm	HCS	5	792148-9
	No.3020	10	150	For wood, plywood 5mm - 90mm	HCS	5	A-02319
	No.3023	10	250	For thick wood 5mm - 190mm	HCS	5	B-00767
WOOD / FAST							
	No.23B	6	150	For fast finish work in wood 10mm - 90mm	HCS	5	792707-9
	No.3019	4	150	For fast and rough cutting in thick wood: 20mm - 90mm	HCS	5	A-02303
	No.3030	6	300	For roughing work in thick wood 10mm - 250mm	HCS	5	B-03030

Reciprocating Saw Blade for Metal

Type	No	Teeth per inch	Overall length (mm)	Application	Tooth Material	Per pkg.	Part No.
	No.21	24	125	For steel plate 1.5mm - 3.0mm For iron pipe 50mm dia. or less	HSS	5	792146-3
	No.22	18	165	For steel plate, aluminum 3.0mm - 5.0mm For iron pipe 90mm dia. or less	HSS	5	792147-1
	No.24	24	165	For steel plate 1.5mm - 3.0mm For iron pipe 90mm dia. or less	HSS	5	792149-7

Reciprocating Saw Blade for Wood / Metal (Heavy) (long life)

Type	Teeth per inch	Overall length (mm)	Blade Thickness (mm)	Application	Tooth Material	Per pkg.	Part No.
	6-8	152	1.25	Wood with nails/metal, chipboards (10-100mm), plastics/Glass fibre reinforced plastics (10-100mm) wooden pallets	TC/HM	1	B-49834
	6-8	228	1.25	Wood with nails/metal, chipboards (10-175mm), plastics/Glass fibre reinforced plastics (10-175mm), wooden pallets	TC/HM	1	B-49840
	6-8	305	1.25	Wood with nails/metal, chipboards (10-250mm), plastics/Glass fibre reinforced plastics (10-250mm), wooden pallets	TC/HM	1	B-49856

Reciprocating Saw Blade for Bi-Metal

Type	No	Teeth per inch	Overall length (mm)	Application	Tooth Material	Per pkg.	Part No.
	10	300		For cuts in thick metal	Bi Metal	3	P-46981

Reciprocating Saw Blade for Insulation Material

Specially designed knife shaped Reciprocating Saw Blades are suitable for cutting insulation materials such as Urethane or Glass Wool.

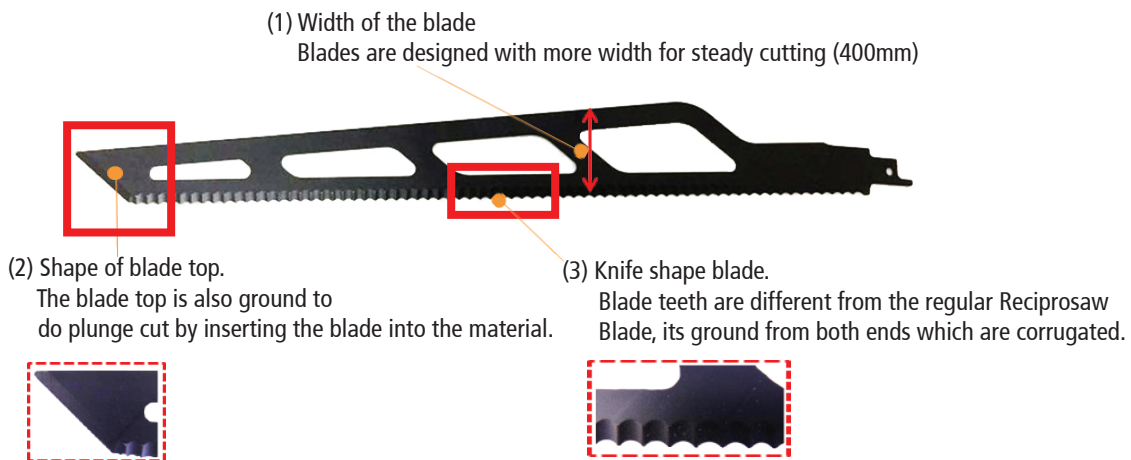

Type	No	Teeth per inch	Overall length (mm)	Application	Tooth Material	Per pkg.	Part No.
		225		Insulation Material, Glass Wool, Stone Wool (10-175mm)	HCS	2	B-52118
		300		Insulation Material, Glass Wool, Stone Wool (10-250mm)	HCS	2	B-52124
		400		Insulation Material, Glass Wool, Stone Wool (10-300mm)	HCS	1	B-52130

Reciprocating Saw Blade Super Express (5pcs per pack)

5pcs per pack

Type	No	Teeth per inch	Overall length (mm)	Application	Tooth Material	Per pkg.	Part No.
	No.21	7-18	152	Fast Cut for metal. (Iron/steel: 1.5 - 8.0mm, Plastic 5-77mm)	Bi-Metal	5	B-05038
	No.22	6-11	152	Fast cuts in non-ferrous metal, aluminium, plastics and wood with nails, steel (Iron/steel: 5-8mm, Plastics: 5-77mm, Wood: 5-77mm)	Bi-Metal	5	B-05044
	No.24	6-10	203	For fast cuts in wood	HCS	5	B-05153

Reciprocating Saw Blade Super Express (2pcs per pack)



Type	No	Teeth per inch	Overall length (mm)	Application	Tooth Material	Per pkg.	Part No.
	No.21	7-18	152	Fast Cut for metal. (Iron/steel: 1.5 - 8.0mm, Plastic 5-77mm)	Bi-Metal	2	B-05038-2
	No.22	6-11	152	Fast cuts in non-ferrous metal, aluminium, plastics and wood with nails, steel (Iron/steel: 5-8mm, Plastics: 5-77mm, Wood: 5-77mm)	Bi-Metal	2	B-05044-2
	No.24	6-10	203	For fast cuts in wood	HCS	2	B-05153-2

BATTERY / CHARGERS

FIXING FASTENING (SCREWDRIVER BITS / IMPACT SOCKETS)

DRILLING (WOOD / METAL / MASONRY)

DRILLING / DEMOLITION (CONCRETE)

CUTTING (METAL)

MULTI TOOL ACCESSORIES

DIAMOND (CUTTING / GRINDING)

GRINDING ACCESSORIES

SANDING / POLISHING ACCESSORIES

SAWING ACCESSORIES

ROUTERS / PLANERS ACCESSORIES

CLEANERS ACCESSORIES

HEAT GUN / LASERS ACCESSORIES

BRAD NAILS/ PINS STAPLER

GARDEN TOOLS ACCESSORIES

HAND TOOLS / COMBINATION SETS

BATTERY / CHARGERS

FIXING FASTENING (SCREWDRIVER BITS / IMPACT SOCKETS)

DRILLING (WOOD / METAL / MASONRY)

DRILLING / DEMOLITION [CONCRETE]

CUTTING [METAL]

MULTI TOOL ACCESSORIES

DIAMOND [CUTTING / GRINDING]

GRINDING ACCESSORIES

SANDING / POLISHING ACCESSORIES

SAWING ACCESSORIES

ROUTERS / PLANERS ACCESSORIES

CLEANERS ACCESSORIES

HEAT GUN / LASERS ACCESSORIES

BRAD NAILS/ PINS STAPLER

GARDEN TOOLS ACCESSORIES

HAND TOOLS / COMBINATION SETS

Scroll Saw Blade



For Model	PC / Pkg	Part No.
SJ401 (Scroll saw blade)	1	(SJ)351011-000

Band Saw Blades

For Model: LB1200F



Blade type	Width x Length (mm)	Thickness	Teeth Per Inch (TPI)	Application	Pcs per package	Part No.
HCS	13 X 2240mm	0.5	4	Wood / Universal	3	B-16673
HCS	16 X 2240mm	0.5	4	Wood / Cross-cut	3	B-16667
HCS	6 X 2240mm	0.5	6	Wood / Curve-cut	3	B-16689
HCS	16 X 2240mm	0.5	14	Nonferrous metal	3	B-16695

Portable Band Saw Blades

For Model : DPB180 / 2106/ 2106W / 2107FK



Blade type	WX L (mm)	Thickness (mm)	Thickness of work piece	Teeth Per Inch (TPI)	Application	Pcs per package	Part No.
Carbon steel	1140 x 13mm	0.5	-	6	Wood	3	792567-9
Carbon steel	1140 x 13mm	0.5	More than 5mm	14	Plastics and non ferrous metals. Mild steel, cast steel and cast iron	3	792560-3
Carbon steel	1140 x 13mm	0.5	4 - 5mm	18		3	792559-8
Carbon steel	1140 x 13mm	0.5	Less than 4mm	24		3	792558-0
Bi-Metal	1140 x 13mm	0.5	More than 5mm	14	Plastics and non ferrous metals. Mild steel, cast steel and cast iron. Hard steel and stainless steel	1	792557-2
Bi-Metal	1140 x 13mm	0.5	4 - 5mm	18		1	792556-4
Bi-Metal	1140 x 13mm	0.5	Less than 4mm	24 WAVE TEETH		1	194692-6

For Model: DPB181 / DPB182 / DPB183

Blade type	WX L (mm)	Thickness (mm)	Thickness of work piece	Teeth Per Inch (TPI)	Application	Pcs per package	Part No.
Bi-Metal	835 x 13mm	0.5	3mm-6 mm	14 WAVE TEETH	Plastics and non-ferrous metal. Mild steel, cast steel and cast iron. Hard steel and stainless steel.	5	B-40543
Bi-Metal	835 x 13mm	0.5	2 mm- 3 mm	18 WAVE TEETH		5	B-40559
Bi-Metal	835 x 13mm	0.5	less than 2mm	24 WAVE TEETH		5	B-40565

Table and stand



For Model	Part No
Table Saw MLT100 , 2703	JM27000300



For Model	Part No
Table Saw 2703, 2704	194093-8



For Model	Part No
All Slide Compound Saw, Miter Saw	194043-3



For Model	Part No
Miter Saws: LS1440, LS1013, LS1214, LS1045, LS1030	P-63750

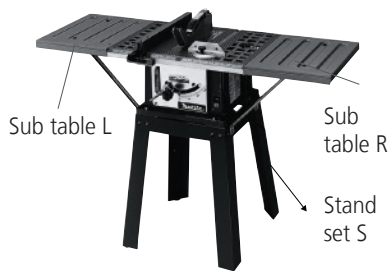

For Model	Part No
Table Saw: 2703	L 192798-4
	R 192797-6
	S 193920-6

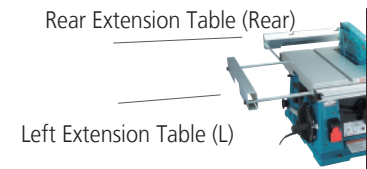

For Model	Part No
Table Saw: 2704	Rear 194087-3
	L 194086-5

Portable Miter Saw Stand



For Model	Part No
All slide compound saw, Miter saw, Table top miter saw	WST05

Folding Miter Saw Stand

Max extension length: 2,550mm Min length: 1,150 mm



For Model	Part No
All slide compound saw, Miter saw, Table top miter saw	WST06

Folding Miter Saw Stand

Max extension length: 3,830mm Min length: 1,765 mm



For Model	Part No
All slide compound saw, Miter saw, Table top miter saw	WST07

BATTERY /
CHARGERS

FIXING FASTENING
(SCREWDRIVER BITS
/ IMPACT SOCKETS)

DRILLING
(WOOD / METAL/
MASONRY)

DRILLING
/ DEMOLITION
(CONCRETE)

CUTTING
(METAL)

MULTI TOOL
ACCESSORIES

DIAMOND
(CUTTING / GRINDING)

GRINDING
ACCESSORIES

SANDING
/ POLISHING
ACCESSORIES

SAWING
ACCESSORIES

ROUTERS
/ PLANERS
ACCESSORIES

CLEANERS
ACCESSORIES

HEAT GUN / LASERS
ACCESSORIES

BRAD NAILS/ PINS
STAPLER

GARDEN TOOLS
ACCESSORIES

HAND TOOLS /
COMBINATION SETS

BATTERY / CHARGERS

FIXING FASTENING (SCREWDRIVER BITS / IMPACT SOCKETS)

DRILLING (WOOD / METAL / MASONRY)

DRILLING / DEMOLITION [CONCRETE]

CUTTING [METAL]

MULTI TOOL ACCESSORIES

DIAMOND [CUTTING / GRINDING]

GRINDING ACCESSORIES

SANDING / POLISHING ACCESSORIES

SAWING ACCESSORIES

ROUTERS / PLANERS ACCESSORIES

CLEANERS ACCESSORIES

HEAT GUN / LASERS ACCESSORIES

BRAD NAILS/ PINS STAPLER

GARDEN TOOLS ACCESSORIES

HAND TOOLS / COMBINATION SETS

Guide Rail and Guide Rail Accessories

- For use with Makita Plunge Saw SP6000, DSP600, DSP6001 also use with selected jig saws with the help of adapter.
- Interacts with the saw base and engineered to deliver smooth, dead-on straight or bevel cutting
- Ideal for ripping sheet material



For Model	Overall length (m)	Part No.
For Plunge cut Saw models SP6000, DSP600, DSP601 For Jig Saw models 4350T/CT/FCT, 4351FCT, DJV180 by using jig saw adapter (193517-1)	1.4 m	194368-5
	3.0 m	194367-7
Guide rail connector - For linking Makita guide rails together	-	198885-7
Splinter guide for Guide rail	3.0 m	423360-7
Guide Rail bag	1.4 m	B-57613

Clamp Set

Type	Part No.
A	194385-5
B	199826-6

Guide Rule (Rip Fence)

Type	For Model	Part No.
Guide rule for circular saws	DCS553, DHS660, DHS661, DHS680 5800NB, 5806B, 5057KB, 5600NB, 5604R, 5704R, 5740NB	164095-8
	5900B	164021-7
	DHS901, N5900B, HS0600	164367-1
	5103N, 5201N, 5401N, 5402	164019-4
	5903, 5903R	165084-6
	SP6000 (Sub base)	165447-6
	DRS780	165153-3
	LS1211	316480-3
	LS1013	316840-9
	LS1045	316826-3
Guide rule for slide compound / miter saws	4300BV, 4300BA	- 164113-2
	4304, 4304T, 4305	- 192424-5
	4326/M, 4327/M, 4328, 4329, JV100D, JV102D, JV103D, JV183D	A 192732-4
Guide rule for Jigsaws	A:Guide rule & circular guide set B:Circular guide assembly	
	4350T/CT/FCT, 4351FCT, DJV180	A 193516-3
	4300BA/BV	B 123030-5
	4304/T, 4331D, 4305	B 192561-5



Guide Rule

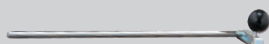

Circular guide assembly

Rip Fence Assembly



For Model	Part No.
2704	122740-1
LF1000	122729-9
LH1040	122707-9
2702, 2703	122556-4
2708	122284-1
MLT100	JM27000202
LH1201FL	JM23300008

Vice Assembly



Vertical vice assembly

For Model	Part No.
LS1040	122536-0
LS0714, DLS714, DLS713	122571-8
LS1212, LS1030	192672-6
LH1040	192625-5
LS1214/F, LS1013	122538-6
LS1212, LS1214	122540-9
LS1016, LS1216	122854-6
DLS211, DLS111, LS1019L, LS1219L LS1016, LS1216	126617-2
LS1018L, LH1201FL	JM23100502

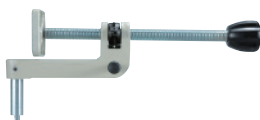

Horizontal vice assembly

For Model	Part No.
DLS211, DLS111, LS1019L, LS1219L LS1016, LS1216, LH1201FL	122470-4
LS1440, LS1045, LS1040, LH1040	122563-7
LS1510	134529-5
LS0714, DLS713, DLS714	122567-9
LS1216, LS1219L, LS1018L	122930-6

Blade Clamp Assembly



For use of 6.35mm Universal Shank Blades

For Model	Part No.
Jig saw - 4300BA / BV	132276-260

Dust Bag Assembly & Dust Box Set



A: Dust bag assembly



B: Dust box set

For Model	Type	Part No.
LS1011, LS1020, LS1030	A	122351-2
LS1211	A	122469-9
LS1440	A	122330-0
DLS714, LS0714, LS1040, LF1000	A	122523-9
DLS111, DLS211, LS1219L, LS1019L, LH1040	A	122852-0
LS1018L	A	JM23100501
LS0714, LS1013, LS1214, LS1016, LS1216	B	194175-6

Safety Goggles



	Part No.
Safety wear	191686-2

BATTERY /
CHARGERS

FIXING FASTENING
(SCREWDRIVER BITS
/ IMPACT SOCKETS)

DRILLING
(WOOD / METAL/
MASONRY)

DRILLING
/ DEMOLITION
(CONCRETE)

CUTTING
(METAL)

MULTI TOOL
ACCESSORIES

DIAMOND
(CUTTING / GRINDING)

GRINDING
ACCESSORIES

SANDING
/ POLISHING
ACCESSORIES

SAWING
ACCESSORIES

ROUTERS
/ PLANERS
ACCESSORIES

CLEANERS
ACCESSORIES

HEAT GUN / LASERS
ACCESSORIES

BRAD NAILS/ PINS
STAPLER

GARDEN TOOLS
ACCESSORIES

HAND TOOLS /
COMBINATION SETS

Router / Planer Accessories

Router Bits / Planer Blades



Router Bits (Standard Range)



- Standard Range of router bits
- The bits come in a compact and attractive case which can be label space beautifully displayed on the display stands

Straight Bit (1 Flute)

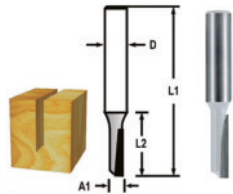

A1	L2	L1	D	Flutes	Part No.
3	13	51	8	1	D-47379
4	13	51	8	1	D-47385
6	19	50.8	8	1	D-47400
6	19	50.8	6	1	D-47416

Straight Bit (2 Flute)

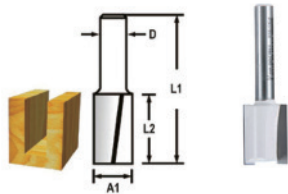

A1	L2	L1	D	Flutes	Part No.
6	16	48	6	2	D-47422
6	25	57	6	2	D-47438
8	19	51	6	2	D-47444
8	25.4	57.4	6	2	D-47450
10	25.4	57.4	6	2	D-47466
14	19.1	51	6	2	D-47488
6	16	48	8	2	D-47503
6	19	51	8	2	D-47519
8	19.1	51	8	2	D-47525
10	19.1	51	8	2	D-47531
20	19.1	51	8	2	D-47581
22	25.4	57.4	8	2	D-47597
24	25.4	57	8	2	D-47606
10	25.4	70	12	2	D-47628
18	32	73	12	2	D-47662
25	32	73	12	2	D-47684

Flush Trim Bit

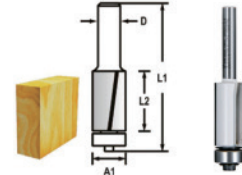

A1	L2	L1	D	Bearing size (mm)	Flutes	Part No.
9.5	26	66.9	6	9.5	2	D-47690
12.7	13	56	6	12.7	2	D-47709
12.7	26	68.5	6	12.7	2	D-47715
9.5	26	67	8	9.5	2	D-47721
12.7	13	55.7	8	12.7	2	D-47737

V Groove Bit

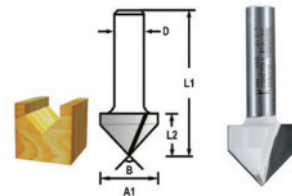

A1	L2	L1	B	D	Flutes	Part No.
12.7	12.7	44.7	90°	6	2	D-47868
12.7	16	48	60°	6	2	D-47874
19	16	47.6	90°	6	2	D-47880
12.7	12.7	44.7	90°	8	2	D-47896
15.9	12.7	44	90°	8	2	D-47905
12.7	12.7	54	90°	12	2	D-47911
15.9	12.7	50.8	90°	12	2	D-47927
19.05	16	47.6	90°	8	2	D-47933
19.05	16	57.3	90°	12	2	D-47949
28.6	22.2	60.3	90°	12	2	D-47955
12.7	16	48	60°	8	2	D-47961

Round Nose Bit

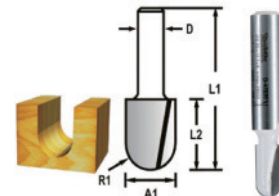

A1	L2	L1	R1	D	Flutes	Part No.
6.35	12.7	44.5	3.2	6	2	D-47802
9.5	12.7	44.5	4.8	6	2	D-47818
6.35	12.7	44.5	3.2	8	2	D-47830
9.5	12.7	44.5	4.8	8	2	D-47846

BATTERY / CHARGERS

FIXING FASTENING (SCREWDRIVER BITS / IMPACT SOCKETS)

DRILLING (WOOD / METAL / MASONRY)

DRILLING / DEMOLITION (CONCRETE)

CUTTING [METAL]

MULTI TOOL ACCESSORIES

DIAMOND [CUTTING / GRINDING]

GRINDING ACCESSORIES

SANDING / POLISHING ACCESSORIES

SAWING ACCESSORIES

ROUTERS / PLANERS ACCESSORIES

CLEANERS ACCESSORIES

HEAT GUN / LASERS ACCESSORIES

BRAD NAILS/ PINS STAPLER

GARDEN TOOLS ACCESSORIES

HAND TOOLS / COMBINATION SETS

Router Bits (Standard Range)

BATTERY / CHARGERS

FIXING FASTENING (SCREWDRIVER BITS / IMPACT SOCKETS)

DRILLING (WOOD / METAL / MASONRY)

Panel Pilot Bit

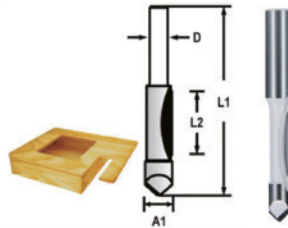

A1	L2	L1	D	Flutes	Part No.
6.35	19	65	6	1	D-47771
6.35	19	65	8	1	D-47787
9.5	26	75	12	1	D-47793

Ovolo Bit

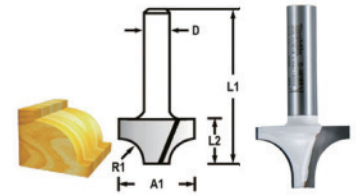

A1	L2	L1	R1	D	Flutes	Part No.
19	9.5	42.5	3.2	6	2	D-48278
25.4	13.5	45.5	6.35	6	2	D-48284

MULTI TOOL ACCESSORIES

Core Box Bit

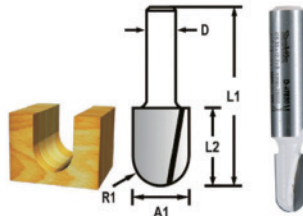

A1	L2	L1	R1	D	Flutes	Part No.
6.35	6.35	38.3	3.2	8	2	D-47977
12.7	10	41.5	6.35	8	2	D-48000

Roundover Bit with Bearing

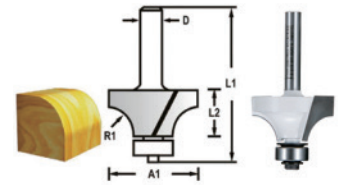

A1	L2	L1	R1	D	Bearing size (mm)	Flutes	Part No.
20.6	10	58.6	4	6	12.7	2	D-48309
25.4	13.5	56.5	6.35	6	12.7	2	D-48315
28.6	14.5	57.3	7.9	6	12.7	2	D-48321
17.3	8	51	2.3	8	12.7	2	D-48343
20.7	10	52.3	4	8	12.7	2	D-48365
2.2	12.7	55	4.8	8	12.7	2	D-48371
25.4	13.5	56.5	6.35	8	12.7	2	D-48387
28.6	14.5	57.3	7.9	8	12.7	2	D-48393

GRINDING ACCESSORIES

Dovetail Bit

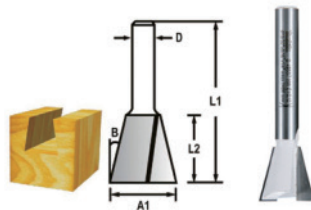

A1	L2	L1	B	D	Flutes	Part No.
6.35	8	63.5	7.5°	8	2	D-48050

SANDING / POLISHING ACCESSORIES

SAWING ACCESSORIES

ROUTERS / PLANERS ACCESSORIES

Classic Plunge Cut Bit

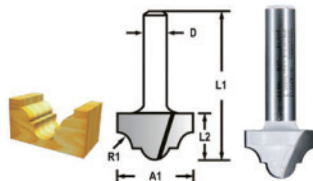

A1	L2	L1	R1	D	Flutes	Part No.
12.7	10	42	2.4	8	2	D-48206
25.4	16	54	5.6	12	2	D-48228

Beading Bit with Bearing

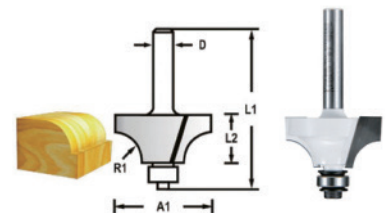

A1	L2	L1	R1	D	Bearing size (mm)	Flutes	Part No.
20.3	10	50.5	4	6	9.5	2	D-48452
22.2	12.7	53.2	4.8	6	9.5	2	D-48468
28.6	14.5	55.5	7.9	6	9.5	2	D-48474
20.7	10	50.5	4	8	9.5	2	D-48505

CLEANERS ACCESSORIES

HEAT GUN / LASERS ACCESSORIES

BRAD NAILS/ PINS STAPLER

GARDEN TOOLS ACCESSORIES

HAND TOOLS / COMBINATION SETS

Router Bits (Standard Range)

Chamfer Bit with Bearing

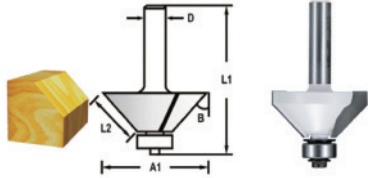

A1	L2	L1	B	D	Bearing size (mm)	Flutes	Part No.
26	11	51	45°	6	12.7	2	D-48658

Reversible Glue Joint Bit (Straight Profile)

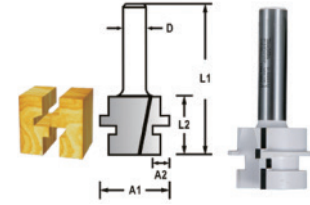

A1	A2	L1	L2	D	Bearing size (mm)	Flutes	Part No.
30.1	6.35	57.2	25.4	8	-	2	D-48913
41.3	7.9	76.2	25.4	12	-	2	D-48929

Roman Ogee Bit with Bearing

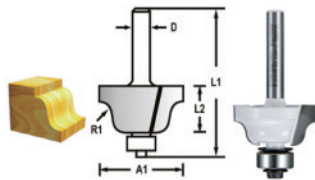

A1	L2	L1	R1	D	Bearing size (mm)	Flutes	Part No.
25.4	9.5	52.5	3.2	6	12.7	2	D-48804
38.1	17.5	60	6.35	8	12.7	2	D-48767

Tongue & Groove Assembly

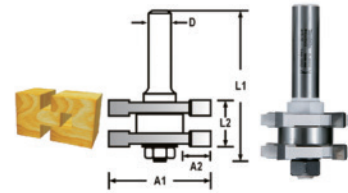

A1	A2	L1	L2	D	Bearing size (mm)	Flutes	Part No.
41	8.5	71	19	12	24	4	D-48935

Ogee Bit with Bearing

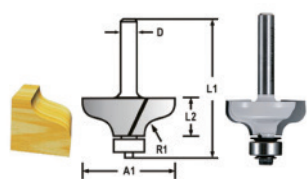

A1	L2	L1	R1	D	Bearing size (mm)	Flutes	Part No.
31.8	12.7	55.6	4.8	8	12.7	2	D-48773

Slotting Cutter (3 Wing Slot Cutter)

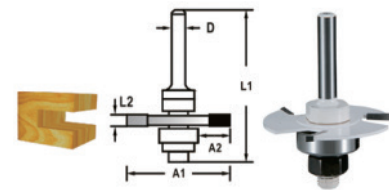

A1	A2	L1	L2	D	Bearing size (mm)	Flutes	Part No.
47.6	12.7	59	2	8	22.2	3	D-48941
47.6	12.7	59	4	8	22.2	3	D-48979

Keyhole Bit

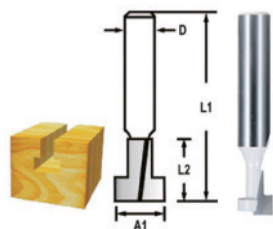

A1	L2	L1	D	Flutes	Part No.
9.5	10.5	48	8	2	D-48907

Slatwall Router Bit



It is used to prepare the groove for hooks to be used for exhibitions, indoor decorations, showrooms, etc. This will enhance our range of router bit

Dia (mm)	Length (mm)	Overall length	Shank (mm)	Flutes	Part No.
38	17.5	55.5	12	2	D-61852

BATTERY / CHARGERS

FIXING FASTENING (SCREWDRIVER BITS / IMPACT SOCKETS)

DRILLING (WOOD / METAL / MASONRY)

DRILLING / DEMOLITION (CONCRETE)

CUTTING [METAL]

MULTI TOOL ACCESSORIES

DIAMOND [CUTTING / GRINDING]

GRINDING ACCESSORIES

SANDING / POLISHING ACCESSORIES

SAWING ACCESSORIES

ROUTERS / PLANERS ACCESSORIES

CLEANERS ACCESSORIES

HEAT GUN / LASERS ACCESSORIES

BRAD NAILS/ PINS STAPLER

GARDEN TOOLS ACCESSORIES

HAND TOOLS / COMBINATION SETS

Router Bits

Straight Bit

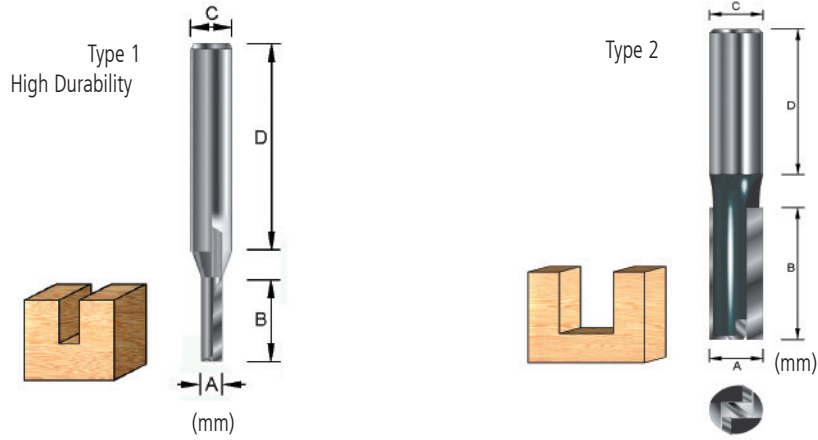

	A	B	C	D	Type	Part No.	Part No.
MULTI TOOL ACCESSORIES	2	8.0	6	32	1	-	D-12114
	3	8.0	6	32	1	-	D-12120
	3	12.0	6	32	1	-	D-12136
DIAMOND [CUTTING / GRINDING]	3.18	12.7	6	32	1	-	D-12142
	3.97	12.7	6	32	1	-	D-12158
	4	12.0	6	32	1	-	D-12164
	4.76	15.9	6	32	1	-	D-12170
GRINDING ACCESSORIES	5	20.0	6	32	1	-	D-12186
	6	20.0	6	32	1	-	D-12192
SANDING / POLISHING ACCESSORIES	20	20.0	6	32	1	793143-2	D-13742
	3	15.9	6	32	2	-	D-13409
	6	16.0	6	32	2	-	D-13415
	6	25.4	6	32	2	-	D-13502
	6	16.0	6	32	2	-	D-13627
	6	16.0	6	32	2	-	D-08816
SAWING ACCESSORIES	6	18.0	6	30	2	-	D-13910
	6	19.0	6	32	2	-	D-13633
	6	25.4	6	32	2	-	D-13649
	6.35	25.4	6	32	1	-	D-12201
ROUTERS / PLANERS ACCESSORIES	8	18.0	6	32.5	2	-	D-13926
	8	20.0	6	32	2	-	D-13655
	8	25.0	6	32	2	-	D-13661
	8	25.0	6	32	2	-	D-13518
	10	25.0	6	32	2	-	D-13677
	12	25.4	6	32	2	-	D-13683
	6	18	6.35	35	2	793074-5	-
	8	18	6.35	32	2	-	-
BRAD NAILS/ PINS STAPLER	20	15	6.35	32	2	-	-
	2	6.0	8	32	2	-	D-12217
	8	25.0	8	32	2	793126-2	D-13948
	8	25.0	8	32	2	-	D-13699
	12	38.1	8	32	2	-	D-13524
GARDEN TOOLS ACCESSORIES	12	50.8	8	32	2	-	D-13530
	12	63.5	8	32	2	-	D-13546
	13	20.0	8	32	2	-	D-13552
	13	25.0	8	32	2	-	D-13568
HAND TOOLS / COMBINATION SETS	14	20.0	8	32	2	-	D-13574
	14	31.8	8	32	2	-	D-13708

	A	B	C	D	Type	Part No.	Part No.
ROUTERS / PLANERS ACCESSORIES	10	25.0	12	38	2	-	D-13714
	10	25.0	12	26	2	-	D-13895
	10	31.8	12	38	2	-	D-13421
	12	20.0	12	38	2	-	D-13580
	12	25.4	12	38	2	-	D-13437
	12	30.0	12	25	2	-	D-13904
	12	31.8	12	38	2	-	D-13720
	12	38.1	12	38	2	-	D-13596
	12	38.1	12	38	2	-	D-13443
	12	50.8	12	38	2	-	D-13459
	12	63.5	12	38	2	-	D-13465
	13	20.0	12	38	2	-	D-13471
	13	25.0	12	38	2	-	D-13487
	14	20.0	12	38	2	-	D-13493
	14	31.8	12	38	2	-	D-13605
	ROUTERS / PLANERS ACCESSORIES	16	31.8	12	38	2	-
25.4		25.4	12	38	2	-	D-13736
10		25	12.7	35	2	793102-6	-
ROUTERS / PLANERS ACCESSORIES	12	30.0	12.7	31	2	-	D-07901



Drill Point Flush Trimming Bit

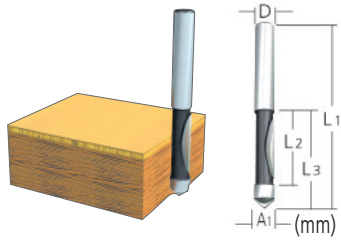

D	A1	L1	L2	L3	Part No.
6.35	6	60	18	28	793108-4
9.5	8	60	20	35	793107-6
12	12	60	20	35	D-10584

Panel Pilot Bit

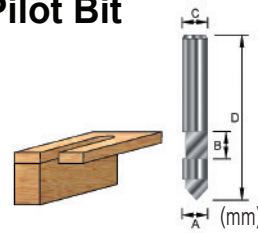

A	B	C	D	Part No.
6	6.35	6	38	D-12348

BATTERY / CHARGERS

FIXING FASTENING (SCREWDRIVER BITS / IMPACT SOCKETS)

DRILLING (WOOD / METAL/ MASONRY)

DRILLING / DEMOLITION (CONCRETE)

Flush Trim Bit

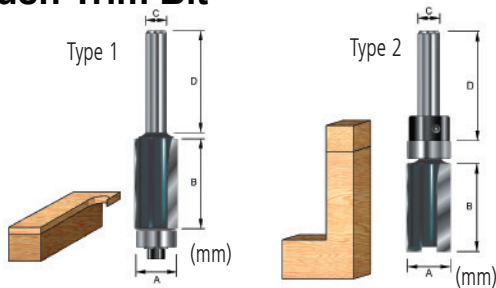

A	B	C	D	Type	Part No.
6.35	19	6	32	1	D-12223
9.5	25.4	6	32	1	D-12239
10	20	6	30	1	D-13932
12.7	25.4	6	32	1	D-12245
9.5	12.7	8	32	1	D-12251
12.7	30.2	8	32	1	D-12267
12.7	50.8	12	38	1	D-10506
12	19	8	32	2	D-12304
12	25	8	32	2	D-12310
28.58	30.16	12	38	2	D-12273
28.58	38.1	12	38	2	D-12289
32	38.1	12	38	2	D-12295

Drill Point Double Flush Trimming Bit

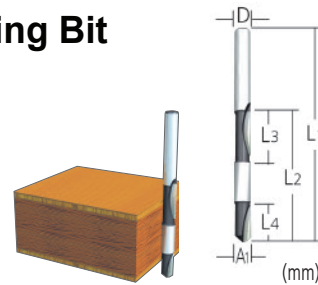

D	A1	L1	L2	L3	L4	Part No.
6	6	70	40	12	14	793091-5
6.35	6	70	40	12	14	793111-5
9.5	8	80	55	20	25	793110-7
12	12	85	60	24	22.5	793127-0

CUTTING [METAL]

MULTI TOOL ACCESSORIES

DIAMOND [CUTTING / GRINDING]

GRINDING ACCESSORIES

SANDING / POLISHING ACCESSORIES

SAWING ACCESSORIES

"V" Groove Bit

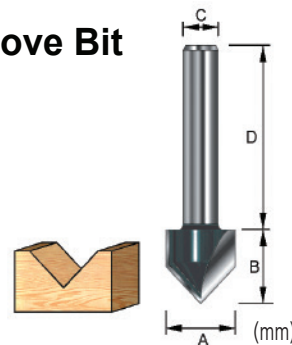

A	B	C	D	Angle	Part No.	Part No.
9.5	9.5	6	32	90°	-	D-12360
12.7	11.11	6	32	90°	-	D-12376
12.7	12.7	6	32	90°	-	D-12398
19.05	15.9	6	32	90°	793193-7	D-12407
20	15	6.35	32	90°	793194-5	-
9.5	9.5	8	32	90°	-	D-12382
9.5	9.5	12	38	90°	-	D-12354

ROUTERS / PLANERS ACCESSORIES

CLEANERS ACCESSORIES

HEAT GUN / LASERS ACCESSORIES

BRAD NAILS/ PINS STAPLER

GARDEN TOOLS ACCESSORIES

HAND TOOLS / COMBINATION SETS

Bevel Trim Bit

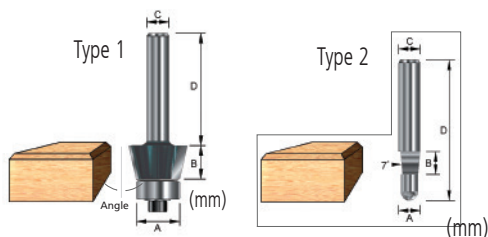

A	B	C	D	Angle	Type	Part No.
6	6.35	6	38	7°	2	D-12332
14.5	9.5	6	32	7°	1	D-12326
19.9	9.5	8	32	22°	1	D-10615

“U” Groove Bit

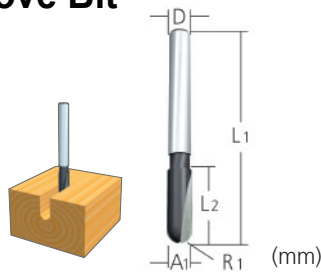

D	A1	L1	L2	R1	Part No.	Part No.
6	6	50	18	3	793328-0	D-09329
6.35	6	50	18	3	793329-8	-
12.7	12	55	20	6	793100-0	-

Beading Bit

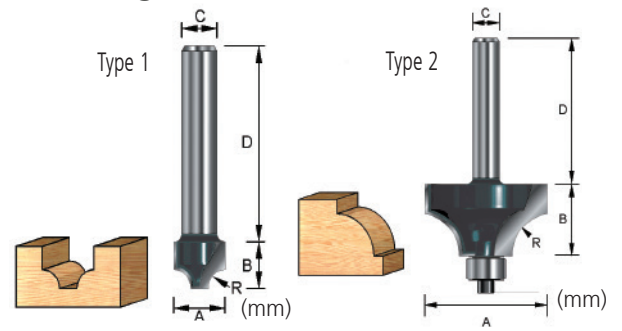

A	B	C	D	R	Type	Part No.	Part No.
12.7	11.11	6	32	4.76	1	-	D-12479
19	9.5	6	32	3.18	2	-	D-12706
20.7	9.5	6	32	4	2	793153-9	D-12712
22.2	9.5	6	32	4.76	2	-	D-12728
24.7	12.7	6	32	6	2	-	D-12734
25.4	11.11	6	32	6.35	2	-	D-12740
28.6	12.7	6	32	8	2	-	D-12756
31.8	15.9	6	32	9.52	2	-	D-12762
20	10	6.35	40	4	2	793170-9	-
26	12	6.35	42	7	2	793171-7	-
32.7	16	8	32	10	2	-	D-13823
38.1	19	8	32	12.7	2	-	D-11368
30	20	12	35	4	2	793071-1	-
32.7	16	12	38	10	2	-	D-12681
36.7	19	12	38	12	2	-	D-13839
50.8	25.4	12	38	19.05	2	-	D-11374
88.9	44.45	12	45	38.1	2	-	D-12697
30	20	12.7	35	4	2	793113-1	-

Core Box Bit

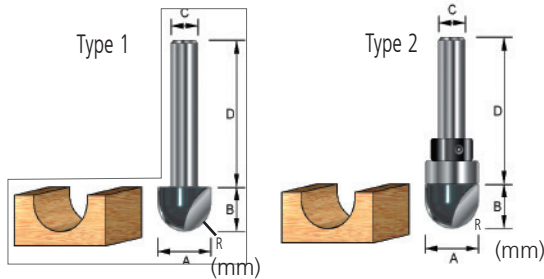

A	B	C	D	R	Type	Part No.
6	6	6	32	3	1	D-12441
12.7	12.7	6	38	-	2	D-12550
12	9.5	8	32	6	1	D-10805
20	16	8	32	10	1	D-12457
12.7	9.5	12	38	6.35	1	D-12429
15.9	12.7	12	38	7.94	1	D-12435

Cove Beading Bit

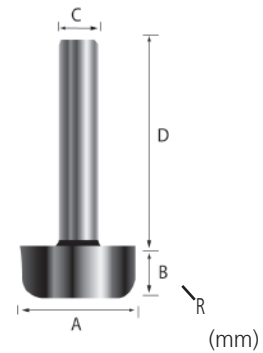

A	B	C	D	R	Part No.
20	8	6	39	4R	793146-6
25	13	6	35	8R	793147-4
20	8	6.35	39	4RE	793163-6
26	13	6.35	35	8RE	793164-4

Ball Groove Bit

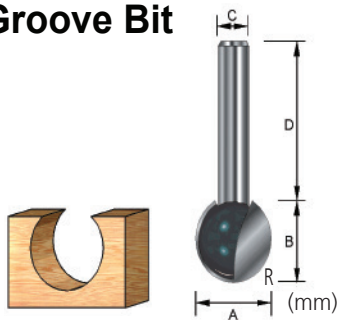

A	B	C	D	R	Part No.
15.9	15.9	6	32	11.11	D-12463

- BATTERY / CHARGERS
- FIXING FASTENING (SCREWDRIVER BITS / IMPACT SOCKETS)
- DRILLING (WOOD / METAL / MASONRY)
- DRILLING / DEMOLITION (CONCRETE)
- CUTTING [METAL]
- MULTI TOOL ACCESSORIES
- DIAMOND [CUTTING / GRINDING]
- GRINDING ACCESSORIES
- SANDING / POLISHING ACCESSORIES
- SAWING ACCESSORIES
- ROUTERS / PLANERS ACCESSORIES
- CLEANERS ACCESSORIES
- HEAT GUN / LASERS ACCESSORIES
- BRAD NAILS/ PINS STAPLER
- GARDEN TOOLS ACCESSORIES
- HAND TOOLS / COMBINATION SETS

Ball Bearing Cove Beading Bit

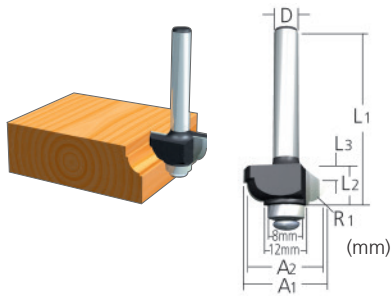

D	A1	A2	L1	L2	L3	R1	Part No.
6	20	18	40	10	5.5	3°	793157-1
6.35	26	22	42	12	5	5°	793175-9
6.35	20	18	40	10	5.5	3°	793174-1

Classic Panel Bit

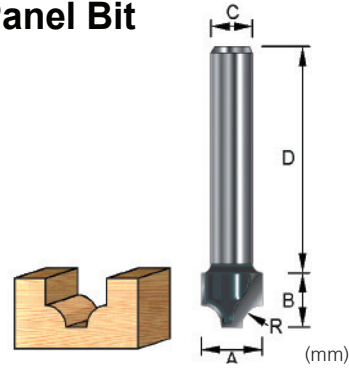

A	B	C	D	R	Part No.
12.7	9.5	6	32	2.38°	D-12522
19.05	12.7	6	32	3.97°	D-12538
12.7	9.5	8	32	2.38°	D-11069
19.05	12.7	8	32	3.97°	D-11075
12.7	9.5	12	38	2.38°	D-12500
19.05	12.7	12	38	3.97°	D-12516
38.1	22.2	12	38	8.73°	D-11097

Dovetail Bit

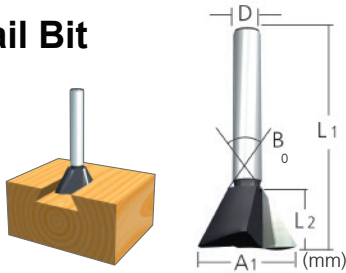

D	A1	L1	L2	B ₀	Part No.
6.35	14.5	55	10	35°	793373-5
6.35	14.5	55	14.5	23°	793374-3
8	12	50	9	30°	793066-4
9.5	14.5	55	10	35°	793124-6
9.5	14.5	55	14.5	23°	793125-4
9.5	12	50	9	30°	793123-8

Classic Beading Bit

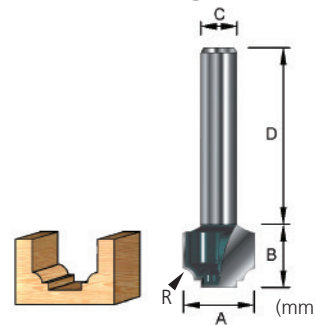

A	B	C	D	R	Part No.
19.05	11.11	12	38	3.18°	D-12544

Ogee Bit

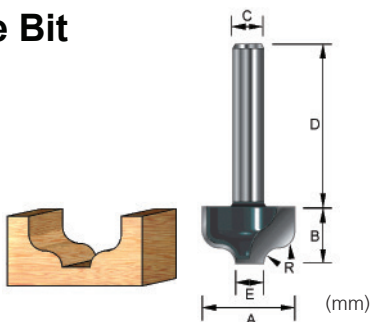

A	B	C	D	E	R	Part No.
12.7	9.5	6	32	4.76	1.98°	D-12485
19.05	11.11	6	32	6.35	3.18°	D-12491

Pierce & Round Over Bit (Plunge Cutting)

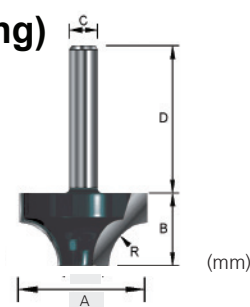

A	B	C	D	R	Part No.
38.1	22.2	8	32	12.7°	D-13889

BATTERY / CHARGERS

FIXING FASTENING (SCREWDRIVER BITS / IMPACT SOCKETS)

DRILLING (WOOD / METAL / MASONRY)

DRILLING / DEMOLITION (CONCRETE)

CUTTING (METAL)

MULTI TOOL ACCESSORIES

DIAMOND (CUTTING / GRINDING)

GRINDING ACCESSORIES

SANDING / POLISHING ACCESSORIES

SAWING ACCESSORIES

ROUTERS / PLANERS ACCESSORIES

CLEANERS ACCESSORIES

HEAT GUN / LASERS ACCESSORIES

BRAD NAILS/ PINS STAPLER

GARDEN TOOLS ACCESSORIES

HAND TOOLS / COMBINATION SETS

Cove & Bead Bit

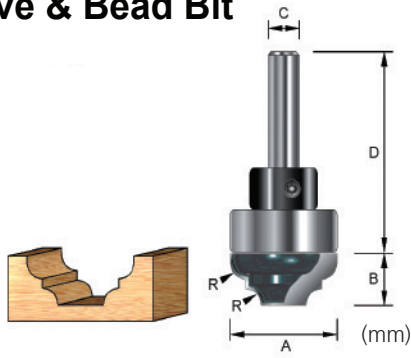

A	B	C	D	R	Part No.
22	9.9	8	40	3.18°	D-11156
35	14.28	12	50	5.56°	D-12566

Rounding Over Bit

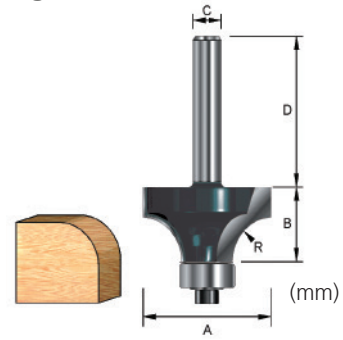

A	B	C	D	R	Part No.	Part No.
15.9	9.5	6	32	1.59°	-	D-12603
19	9.5	6	32	3.18°	-	D-12619
24.7	12.7	6	32	6°	-	D-12625
25.4	11.11	6	32	6.35°	-	D-12631
28.6	12.7	6	32	8°	-	D-12647
31.8	15.9	6	32	9.52°	-	D-12653
38.1	19	6	32	12.7°	-	D-12669
20	10	6.35	35	4°	793105-0	-
25	13	6.35	35	8°	793159-7	-
20.7	9.5	8	32	4°	-	D-11209
24.7	12.7	8	32	6°	-	D-12675
31.8	15.9	8	32	9.52°	-	D-11243
32.7	16	12	38	10°	-	D-12588
36.7	19	12	38	12°	-	D-12594
38.1	19	12	38	12.7°	-	D-13786
20	10	12	40	6°	793070-3	-
20	10	12.7	40	6°	793104-2	-

Classical Plunge Bit

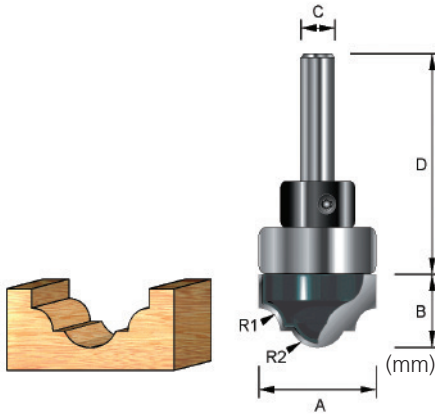

A	B	C	D	R	Part No.
22	12.7	8	40	R1=3.97°, R2=5.55°	D-11178
35	14.28	12	50	R1=6.35°, R2=10.32°	D-12572

Ball Bearing Corner Rounding Bit

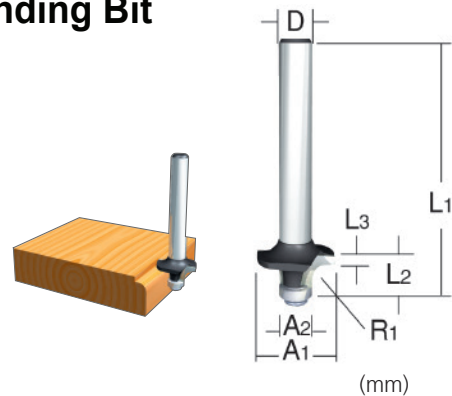

D	A1	A2	L1	L2	L3	R1	Part No.	Part No.
6	15	8	37	7	3.5	3°	793151-3	-
6	21	8	40	10	3.5	6°	-	D-09444
6.35	15	8	37	7	3.5	3°	793168-6	-
6.35	21	8	40	10	3.5	6°	793169-4	-

Classic Mold Bit

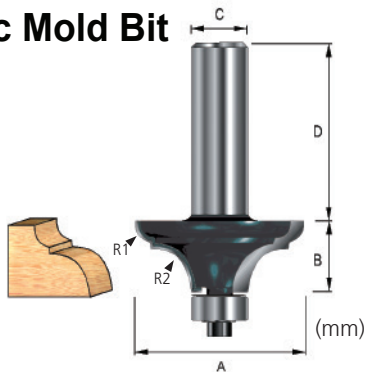

A	B	C	D	R	Part No.
38.1	15.9	8	32	R1=3.18°, R2=9/5°	D-11704
38.1	15.9	12	38	R1=3.18°, R2=9.5°	D-13029

- BATTERY / CHARGERS
- FIXING FASTENING (SCREWDRIVER BITS / IMPACT SOCKETS)
- DRILLING (WOOD / METAL / MASONRY)
- DRILLING / DEMOLITION [CONCRETE]
- CUTTING [METAL]
- MULTI TOOL ACCESSORIES
- DIAMOND [CUTTING / GRINDING]
- GRINDING ACCESSORIES
- SANDING / POLISHING ACCESSORIES
- SAWING ACCESSORIES
- ROUTERS / PLANERS ACCESSORIES
- CLEANERS ACCESSORIES
- HEAT GUN / LASERS ACCESSORIES
- BRAD NAILS/ PINS STAPLER
- GARDEN TOOLS ACCESSORIES
- HAND TOOLS / COMBINATION SETS

Slotting Bit

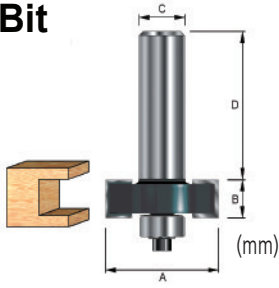

A	B	C	D	Part No.
31.8	3.18	6	32	D-12843
31.8	4.76	6	32	D-12859
31.8	6.35	6	32	D-12865
31.8	7.94	6	32	D-12871
31.8	9.5	6	32	D-12887

Ogee with Fillet Bit

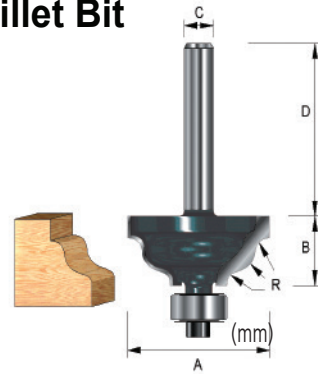

A	B	C	D	R	Part No.
34.9	14.28	8	32	4.76°	D-11586
41.28	17.46	8	32	6.35°	D-11592

Roman Ogee Bit

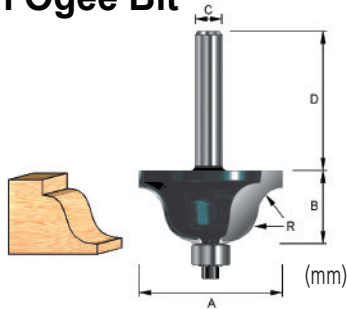

A	B	C	D	R	Part No.
27	11.9	6	32	3.97°	D-12902
34.9	16.6	6	32	6.35°	D-12918
27	11.9	8	32	3.97°	D-11542
34.9	16.6	8	32	6.35°	D-11558
43	25	12	38	8°	D-12893

Classic Ogee Bit

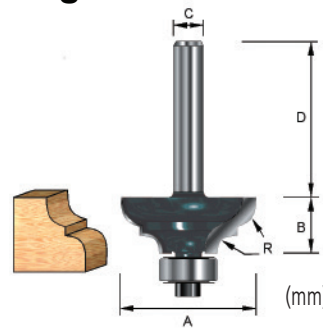

A	B	C	D	R	Part No.
25.4	12.7	6	32	3.18°	D-12946
31.8	14.28	8	32	4.76°	D-11617
38.1	17.46	12	38	6.35°	D-12930

Ogee Bit

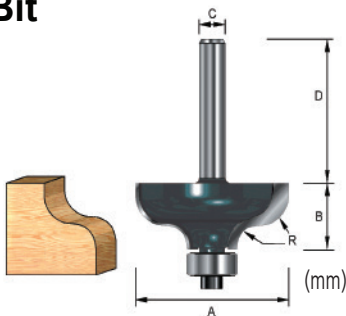

A	B	C	D	R	Part No.
31.8	12.7	8	32	4.76°	D-11564
38.1	17.46	8	32	6.35°	D-11570
38.1	17.46	12	38	6.35°	D-12924

Classic Roman Ogee Bit

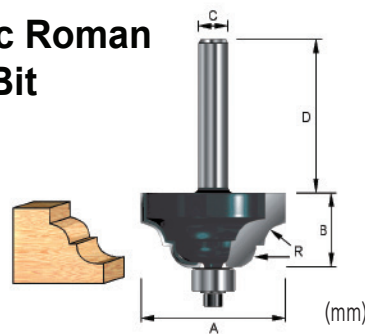

A	B	C	D	R	Part No.	Part No.
20	10	6	30	4.5°	793155-5	-
25.4	12.7	6	32	3.18°	793156-3	D-12968
31.8	15.9	6	32	4.76°	-	D-12974
25.4	12.7	8	32	3.18°	-	D-11639
31.8	15.9	8	32	4.76°	-	D-11645
38.1	19	12	38	6.35°	-	D-12952

BATTERY / CHARGERS

FIXING FASTENING (SCREWDRIVER BITS / IMPACT SOCKETS)

DRILLING (WOOD / METAL / MASONRY)

DRILLING / DEMOLITION (CONCRETE)

CUTTING (METAL)

MULTI TOOL ACCESSORIES

DIAMOND (CUTTING / GRINDING)

GRINDING ACCESSORIES

SANDING / POLISHING ACCESSORIES

SAWING ACCESSORIES

ROUTERS / PLANERS ACCESSORIES

CLEANERS ACCESSORIES

HEAT GUN / LASERS ACCESSORIES

BRAD NAILS/ PINS STAPLER

GARDEN TOOLS ACCESSORIES

HAND TOOLS / COMBINATION SETS

- BATTERY / CHARGERS
- FIXING FASTENING (SCREWDRIVER BITS / IMPACT SOCKETS)
- DRILLING (WOOD / METAL / MASONRY)
- DRILLING / DEMOLITION (CONCRETE)

Double Ball Bearing Round Corner Bit

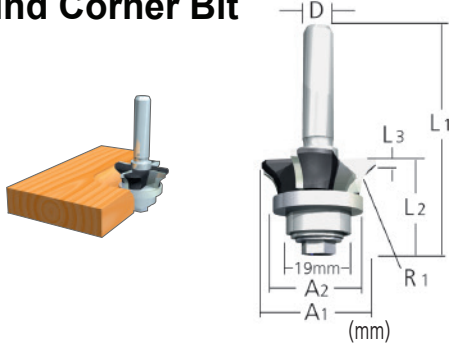

D	A1	A2	L1	L2	L3	R1	Part No.
12	35	27	70	11	3.5	3°	793073-7
12.7	35	27	70	11	3.5	3°	793093-1

- MULTI TOOL ACCESSORIES
- DIAMOND (CUTTING / GRINDING)
- GRINDING ACCESSORIES
- SANDING / POLISHING ACCESSORIES

Double Round Bit

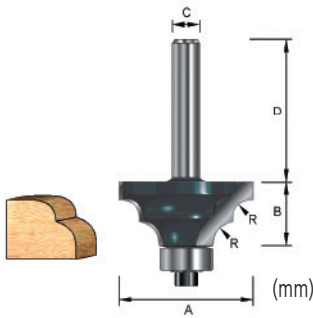

A	B	C	D	R	Part No.
31.8	14.28	6	32	4.76°	D-12784
31.8	14.28	8	32	4.76°	D-11411
38.1	17.46	12	38	6.35°	D-12778

ROUTERS / PLANERS ACCESSORIES

- CLEANERS ACCESSORIES
- HEAT GUN / LASERS ACCESSORIES
- BRAD NAILS/ PINS STAPLER

Cove Bit

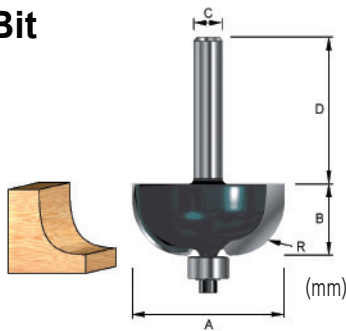

A	B	C	D	R	Part No.
15.9	9.5	6	32	3.18°	D-12790
19	9.5	6	32	4.76°	D-12809
22.2	9.5	6	32	6.35°	D-12815
28.6	12.7	8	32	9.52°	D-11477

- GARDEN TOOLS ACCESSORIES
- HAND TOOLS / COMBINATION SETS

Chamfering Bit

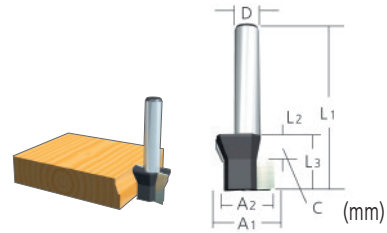

D	A1	A2	L1	L2	L3	C	Part No.
12.7	30	20	55	12	20	4°	793114-9

Chamfer Bit

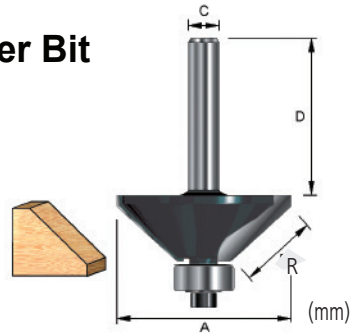

A	C	D	R	Part No.	Part No.
23	6	35	30°	793144-0	-
20	6	35	60°	793145-8	-
23	6.35	35	30°	793161-0	-
20	6.35	35	60°	793162-8	-
26	8	32	45°	-	D-12837
57.15	12	38	45°	-	D-12821

Ball Bearing Chamfering Bit

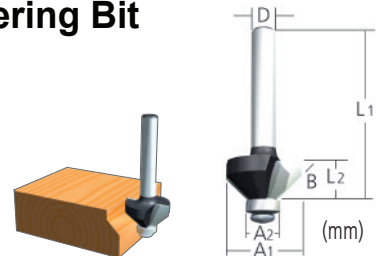

D	A1	A2	L1	L2	B	Part No.
6	20	8	41	11	60°	793150-5
6	26	8	42	12	45°	793149-0
6.35	20	8	41	11	60°	793167-8
6.35	26	8	42	12	45°	793166-0

Cavetto Bit

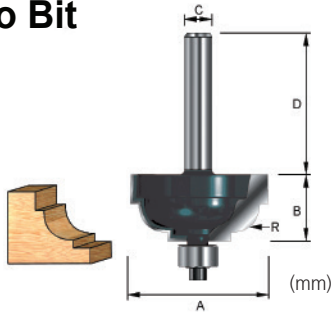

A	B	C	D	R	Part No.
25.4	12.7	6	32	4.76 ⁰	D-12996
28.6	14.28	6	32	6.35 ⁰	D-13007
28.6	14.28	8	32	6.35 ⁰	D-11673
31.8	15.9	8	32	7.94 ⁰	D-11689
31.8	15.9	12	38	7.94 ⁰	D-12980

Bead & Cove Bit

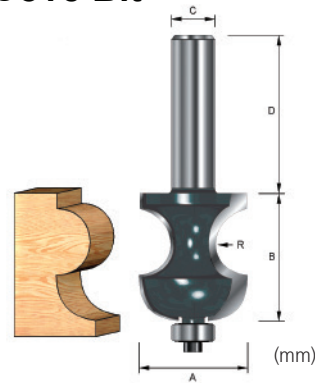

A	B	C	D	R	Part No.
31.8	36.51	8	38	9.52 ⁰	D-13063

Wavy Mold Bit

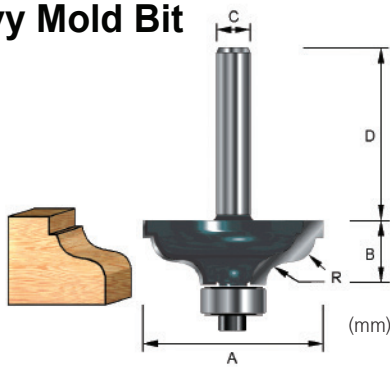

A	B	C	D	R	Part No.
31.8	14.28	8	32	3.18 ⁰	D-11695
31.8	14.28	12	38	3.18 ⁰	D-13013

Multi Reed Bit

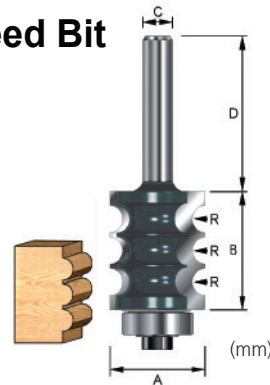

A	B	C	D	R	Part No.
22.2	25.4	6	32	3.18 ⁰	D-13079
22.2	25.4	8	32	3.18 ⁰	D-13085

Decor Sunk Bead Bit / Radius Sunk Bead Bit

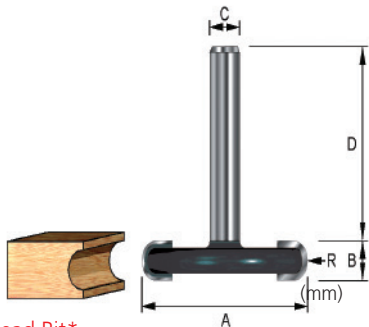

Radius Sunk Bead Bit*

A	B	C	D	R	Part No.
38.1	6.35	6	32	3.18 ⁰	*D-13041
38.1	6.35	6	32	3.18 ⁰	D-13057
38.1	6.35	12	38	3.18 ⁰	D-13035

Three Bead Fluting Bit

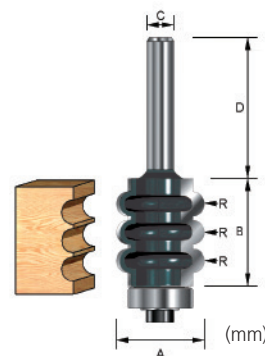

A	B	C	D	R	Part No.
22.2	25.4	6	32	3.18 ⁰	D-13091
22.2	25.4	8	32	3.18 ⁰	D-13100

BATTERY / CHARGERS

FIXING FASTENING (SCREWDRIVER BITS / IMPACT SOCKETS)

DRILLING (WOOD / METAL / MASONRY)

DRILLING / DEMOLITION (CONCRETE)

CUTTING (METAL)

MULTI TOOL ACCESSORIES

DIAMOND (CUTTING / GRINDING)

GRINDING ACCESSORIES

SANDING / POLISHING ACCESSORIES

SAWING ACCESSORIES

ROUTERS / PLANERS ACCESSORIES

CLEANERS ACCESSORIES

HEAT GUN / LASERS ACCESSORIES

BRAD NAILS / PINS STAPLER

GARDEN TOOLS ACCESSORIES

HAND TOOLS / COMBINATION SETS

BATTERY / CHARGERS

FIXING FASTENING (SCREWDRIVER BITS / IMPACT SOCKETS)

DRILLING (WOOD / METAL / MASONRY)

DRILLING / DEMOLITION (CONCRETE)

CUTTING [METAL]

MULTI TOOL ACCESSORIES

DIAMOND [CUTTING / GRINDING]

GRINDING ACCESSORIES

SANDING / POLISHING ACCESSORIES

SAWING ACCESSORIES

ROUTERS / PLANERS ACCESSORIES

CLEANERS ACCESSORIES

HEAT GUN / LASERS ACCESSORIES

BRAD NAILS/ PINS STAPLER

GARDEN TOOLS ACCESSORIES

HAND TOOLS / COMBINATION SETS

Cove & Bead Bit

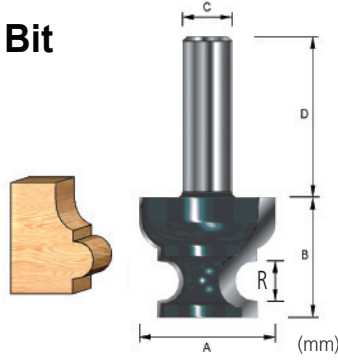

A	B	C	D	R	Part No.
28.6	22.2	12	38	6.35°	D-13116
41.28	31.8	12	38	12.7°	D-13122

Classical Multi Profile Bit

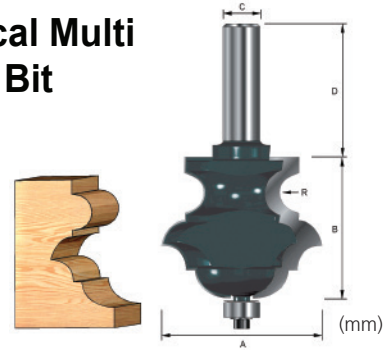

A	B	C	D	R	Part No.
31.8	25.4	8	32	3.97°	D-11760
57.15	47.6	12	45	3.18°	D-11776

Moulding Bit

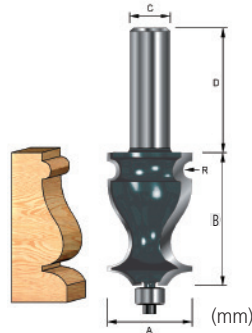

A	B	C	D	R	Part No.
17.46	25.4	6	32	3.18°	D-13194
19	25.4	6	32	1.98°	D-13203
19	25.4	6	32	1.98°	D-13219
17.46	25.4	8	32	3.18°	D-13225
19	25.4	8	32	1.98°	D-13231
23.8	34.9	12	38	3.97°	D-13138
23.8	34.9	12	38	3.97°	D-13144
26.99	41.28	12	38	3.18°	D-11748
25.4	34.9	12	38	3.97°	D-13150
25.4	42.8	12	38	3.18°	D-13166
34.9	41.28	12	38	3.18°	D-13172
38.1	38.1	12	38	3.18°	D-13188

Multi Profile Bit

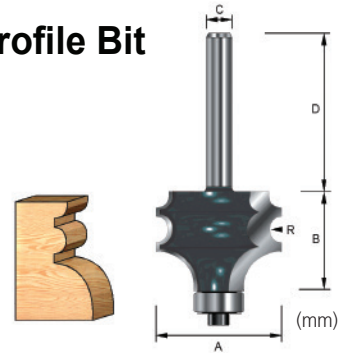

A	B	C	D	R	Part No.
31.8	23.8	12	38	3.18°	D-13253
34.9	19	12	38	2.38°	D-13269
50.8	30.1	12	38	4.76°	D-13275

Multi Profile Bit Decorative Bead Bit

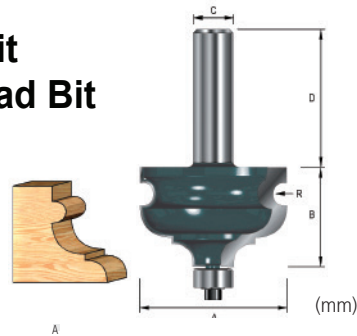

A	B	C	D	R	Part No.
25.4	22.2	12	38	3.97°	D-13247
44.45	28.6	12	38	3.18°	D-11754

Slotting Cutter

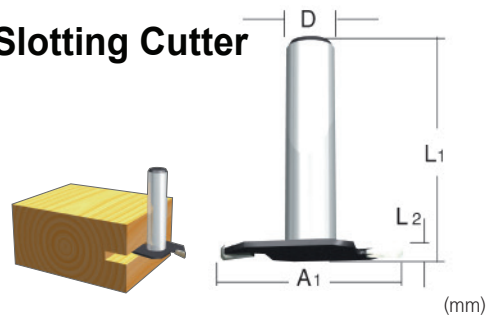

D	A1	L1	L2	Part No.
12	30	55	3	793067-2
12	30	55	6	793068-0
12.7	30	55	3	793122-0

Variable Slot Cutter Set

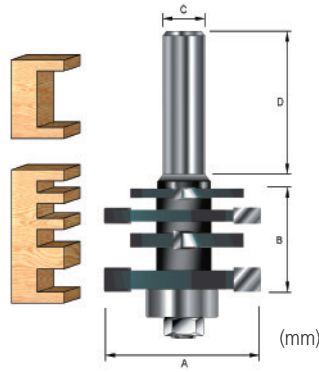

A	B	C	D	Part No.
47.6	18.2	12	38	D-13281

Traditional Table Edge Bit

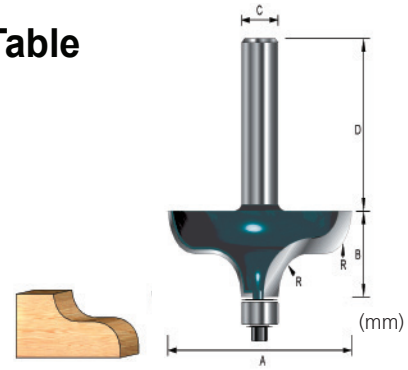

A	B	C	D	R	Part No.
63.5	19	12	38	9.52°	D-11807

BATTERY / CHARGERS

FIXING FASTENING (SCREWDRIVER BITS / IMPACT SOCKETS)

DRILLING (WOOD / METAL / MASONRY)

DRILLING / DEMOLITION (CONCRETE)

CUTTING (METAL)

MULTI TOOL ACCESSORIES

DIAMOND (CUTTING / GRINDING)

GRINDING ACCESSORIES

SANDING / POLISHING ACCESSORIES

SAWING ACCESSORIES

ROUTERS / PLANERS ACCESSORIES

CLEANERS ACCESSORIES

HEAT GUN / LASERS ACCESSORIES

BRAD NAILS/ PINS STAPLER

GARDEN TOOLS ACCESSORIES

HAND TOOLS / COMBINATION SETS

Thumb Mold Bit

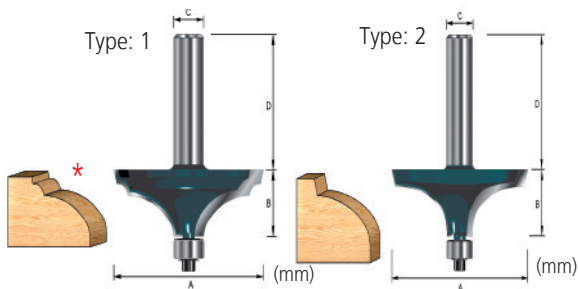

A	B	C	D	Type	Part No.
63.5	19	12	45	2	D-11782
63.5	19	12	38	1	D-13297

Classic Ogee Bit

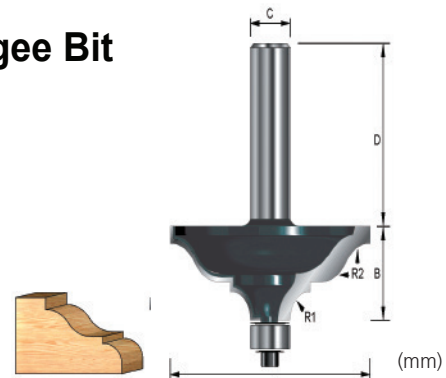

A	B	C	D	R	Part No.
63.5	19.84	12	38	R1=6.35°, R2=9.5°	D-11813

Classic Profile Bit

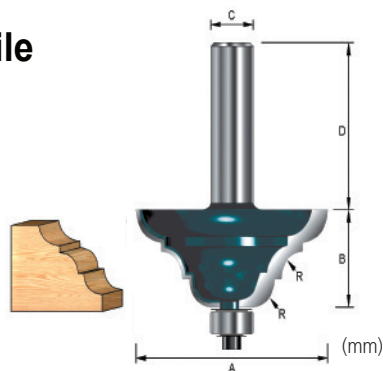

A	B	C	D	R	Part No.
57.15	22.2	12	38	6.35°	D-11798

Handrail Bit

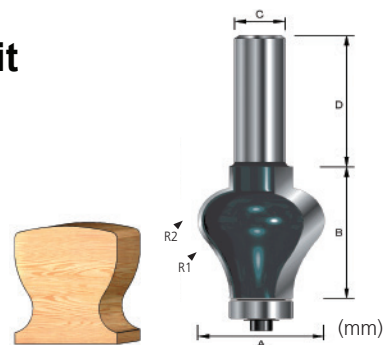

A	B	C	D	R	Part No.
31.8	38.1	12	38	R1=9.52°, R2=12.7°	D-13306

- BATTERY / CHARGERS
- FIXING FASTENING (SCREWDRIVER BITS / IMPACT SOCKETS)
- DRILLING (WOOD / METAL / MASONRY)
- DRILLING / DEMOLITION [CONCRETE]
- CUTTING [METAL]
- MULTI TOOL ACCESSORIES
- DIAMOND [CUTTING / GRINDING]
- GRINDING ACCESSORIES
- SANDING / POLISHING ACCESSORIES
- SAWING ACCESSORIES
- ROUTERS / PLANERS ACCESSORIES
- CLEANERS ACCESSORIES
- HEAT GUN / LASERS ACCESSORIES
- BRAD NAILS/ PINS STAPLER
- GARDEN TOOLS ACCESSORIES
- HAND TOOLS / COMBINATION SETS

Decorative Bead Bit

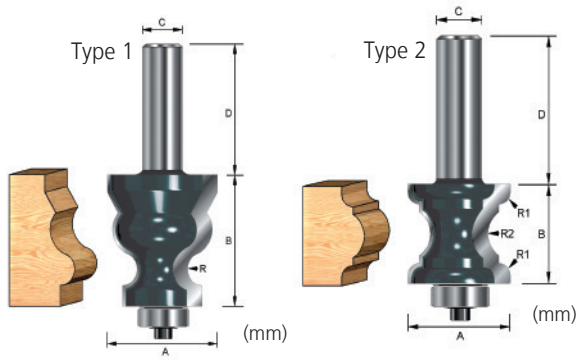

A	B	C	D	R		Part No.
31.8	31.8	12	38	R1=3.97°, R2=7.94°	2	D-13312
34.9	41.28	12	38	R1=4.76°, R2=12.7°	2	D-13328
34.9	38.1	12	38	R = 4.76°	1	D-13334

Crown Molding Bit

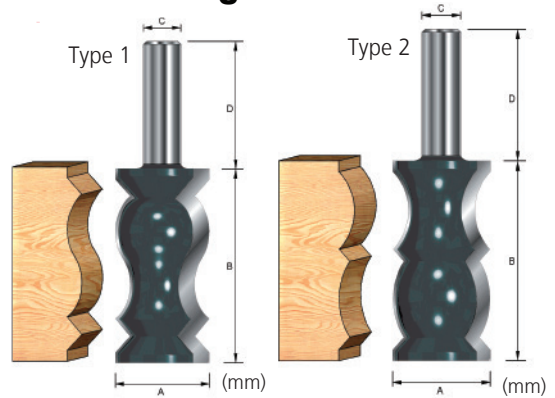

A	B	C	D	Type	Part No.
31.8	57.1	12	38	1	D-13801
31.8	57.1	12	38	2	D-13817

Bullnose Mould Bit

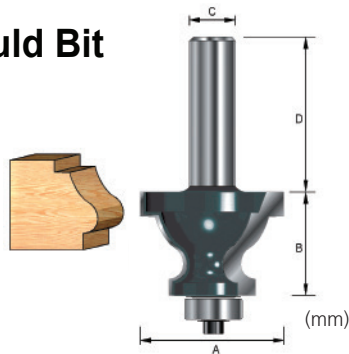

A	B	C	D	Part No.
39.68	25.4	12	38	D-13340

Raised Panel Bit - Wavy

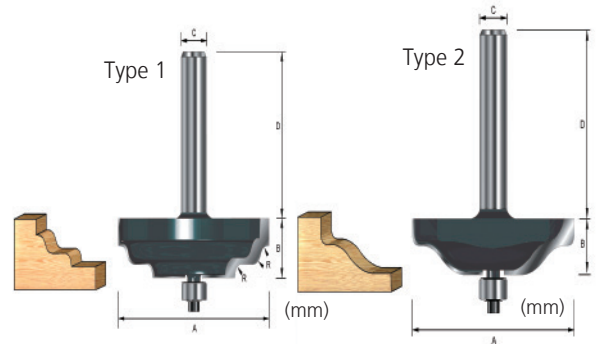

A	B	C	D	Type	Part No.
76.2	19	12	50	1	D-13356
76.2	15.9	12	50	2	D-13362
76.2	15.9	12	50	2	D-13378
76.2	15.9	12	50	2	D-13384

Decorative Bead Bit

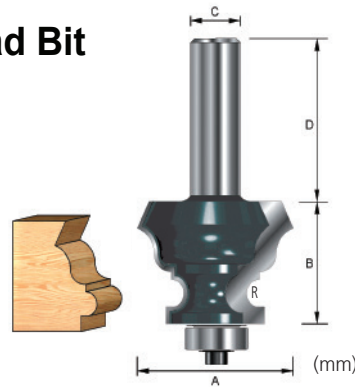

A	B	C	D	R	Part No.
39.7	28.6	12	38	3.18°	D-13792

Door Edge Bit

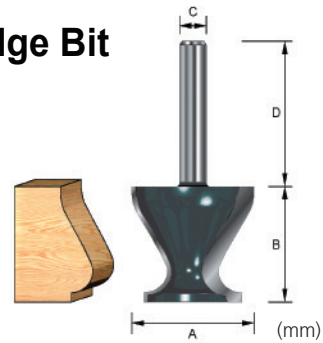

A	B	C	D	Part No.
31.8	25.4	8	32	D-13390

Solid Surface Cutters - Ogee

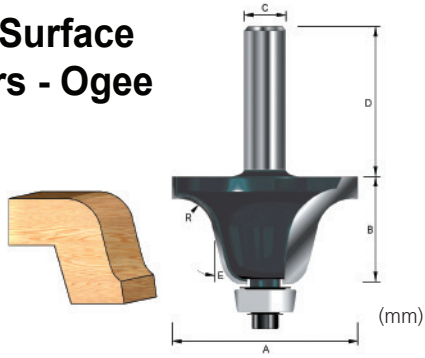

A	B	C	D	E	R	Part No.
51.15	31.8	12	40	15	12.7 ^o	D-13873

Hinge Boring Bit

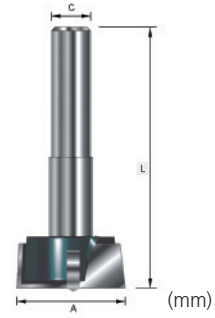

A	C	L	Part No.
20	8	76.2	D-13845
25	8	76.2	D-13867
22.22	10	76.2	D-13851
35	10	76.2	D-13758

Board-Joining Bit

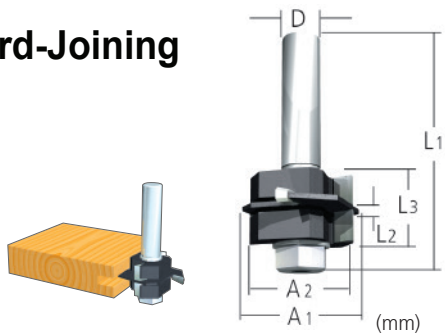

D	A1	A2	L1	L2	L3	Part No.
12	38	26	61	4	20	793189-8
12.7	38	26	61	4	20	793191-1

Straight Sash Router Bit

For Model: 4402

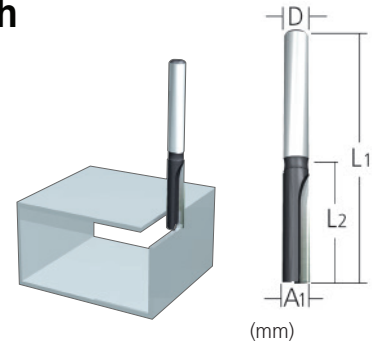

D	A1	L1	L2	Part No.	Part No.
6	6	65	18	-	D-16988
6	8	65	30	793090-7	-
6.35	6.5	60	15	793119-9	-
6.35	8	65	30	793120-4	-

Economy Tongue & Groove Set

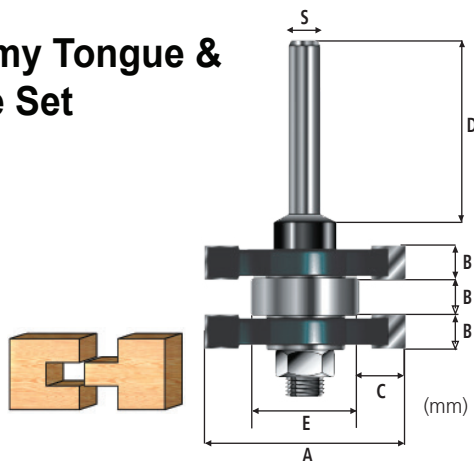

A	B	C	D	E	S	Part No.
41	6.35	9.5	32	32	8	D-12011
41	6.35	9.5	38	22	12	D-12027

BATTERY / CHARGERS

FIXING FASTENING (SCREWDRIVER BITS / IMPACT SOCKETS)

DRILLING (WOOD / METAL / MASONRY)

DRILLING / DEMOLITION (CONCRETE)

CUTTING (METAL)

MULTI TOOL ACCESSORIES

DIAMOND (CUTTING / GRINDING)

GRINDING ACCESSORIES

SANDING / POLISHING ACCESSORIES

SAWING ACCESSORIES

ROUTERS / PLANERS ACCESSORIES

CLEANERS ACCESSORIES

HEAT GUN / LASERS ACCESSORIES

BRAD NAILS/ PINS STAPLER

GARDEN TOOLS ACCESSORIES

HAND TOOLS / COMBINATION SETS

Double Drill Bit

For Model: 4402

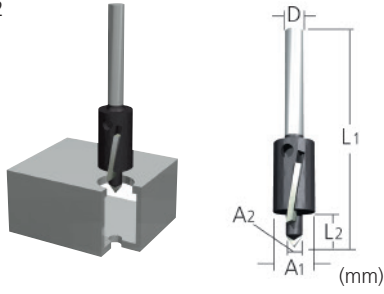

Ball Bearing

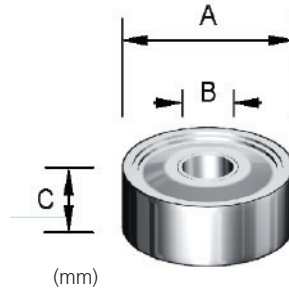

D	A1	A2	L1	L2	Part No.
6	12	6.5	60	12	793082-6
6	14	6.5	60	12	793083-4
6	16	6.5	60	12	793084-2
6	18	6.5	60	12	793085-0
6.35	12	6.5	60	12	793118-1
6.35	14	6.5	60	12	793117-3
6.35	16	6.5	60	12	793116-5
6.35	18	6.5	60	12	793115-7

A	B	C	Part No.
9.52	4.76	3.18	D-13764
12.7	4.76	4.76	D-13770

Router Bit Starter Set (3pcs / Set)

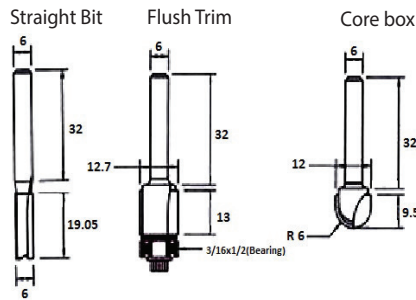

Type / Size	Dia	L	R	Shank	Bearing Size	Flutes	Part No
Straight Bit	6	19.05	-	6	-	1	D-30209
Flush Trim Bit	12.7	13	-	6	12.7	2	
Core Box	12	9.5	6	6	-	2	

Router Bit Set (4 pcs / Set)

1/4" Bit set



Type / Size	Part No
3x 1/4" Straight Bits, Size: 6 x 6.5 x 19mm, 6 x 9.5 x 25mm, 6 x 19 x 25mm,	P-24876
1x 1/4" Round Router Bit, Size: 6 x R6.5 x 25.5mm	

Router Bit Set (12 pcs / Set)

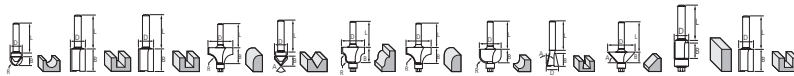

Size	1	2	3	4	5	6	7	8	9	10	11	12	Part No.
8mm	D:12.7 R:6.35 B:8.8	D:16.0 B:20.0 L:28.0	D:6.0 B:20.0 L:25.0	D:28.6 R:9.5 B:17.0 L:25.5	D:12.7 B:9.1 A:90° L:29.0	D:25.0 R:4.0 B:16.0 L:26.5	D:22.2 R:6.3 B:13.5 L:25.0	D:22.0 R:6.3 B:12.7 L:26.5	D:12.7 B:12.7 A:14° L:29.0	D:32.0 B:12.2 A:45° L:30.0	D:12.7 B:13.0 L:29.0	D:12.0 B:20.0 L:28.0	A-88054
6mm													A-87921

- BATTERY / CHARGERS
- FIXING FASTENING (SCREWDRIVER BITS / IMPACT SOCKETS)
- DRILLING (WOOD / METAL / MASONRY)
- DRILLING / DEMOLITION [CONCRETE]
- CUTTING [METAL]
- MULTI TOOL ACCESSORIES
- DIAMOND [CUTTING / GRINDING]
- GRINDING ACCESSORIES
- SANDING / POLISHING ACCESSORIES
- SAWING ACCESSORIES
- ROUTERS / PLANERS ACCESSORIES
- CLEANERS ACCESSORIES
- HEAT GUN / LASERS ACCESSORIES
- BRAD NAILS/ PINS STAPLER
- GARDEN TOOLS ACCESSORIES
- HAND TOOLS / COMBINATION SETS

Templet Guide

For fast production and complicated shapes by using templet.

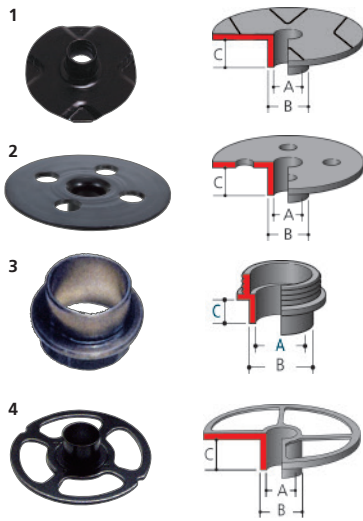

*RT0700C & DRT50 - Use with base assembly

For Model	A (mm)	B (mm)	C (mm)	Part No.
3700B, N3701, 3703, 4402, 3709, 3710	8	10	9.5	343577-5
3606, 3612BR, 3620, 3612C, 3612, RP0900, RP1800, RP2300FC *RT0700C & DRT50	7.7	9.5	11.5	164379-4
	9	11	13	164775-6
	10	12	9	164388-3
	11	12.7	13	164776-4
	14	17	20	165366-6
	14.5	16	13	344364-5
	18	20	13	164393-0
	22	24	13	165364-0
	24	27	13	164470-8
	25	29	15	163080-8
3600, 3600H, 3601B	27	30	13	164471-6
	37	40	13	165046-4
	37	40	13	164472-4
	7.7	9.5	8	343448-2
	9	11	5	323023-4
RP0910, RP1110C	11.1	12.7	14.3	321472-9
	10.9	12.7	8	323449-0
	14	16	8	323018-7
	14	16	14.5	321308-2
	7.7	9.5	8	193330-7
	9	11	5	193331-5
	10.5	12	14	193332-3
	11	12.7	11.5	193333-1
	14	17	20	165365-8
	14.5	16	11.5	193334-9
18	20	13	193335-7	
22	24	13	193340-4	
24	27	13	193336-5	
25	29	13	193337-3	
27	30	13	193338-1	
37	40	13	193339-9	

Templet Guide 25

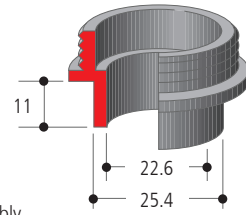

*RT0700C & DRT50 - Use with base assembly

For Model	Part No.
All routers	321812-1

Templet Guide adapter 30

For B&D, Porter Cable, two-piece templet guide.

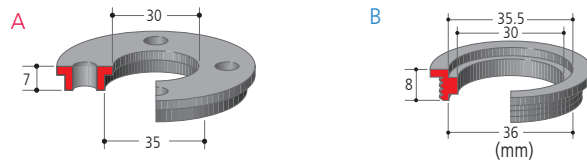

*RT0700C & DRT50 - Use with base assembly

For Model	Type	Part No.
3612 /C/BR, 3620, RP0900, RP1800, RP2300FC, *RT0700C & DRT50	A	321492-3
3600/H, 3601B	B	321493-1

Nut M30

Use with Templet Guide 25 and Templet Guide Adapter 30

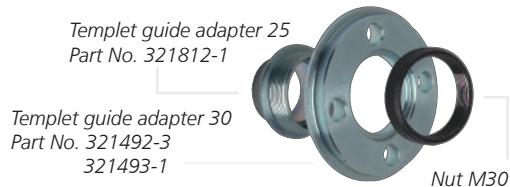

For Model	Part No.
All routers	252627-4



BATTERY / CHARGERS

FIXING FASTENING (SCREWDRIVER BITS / IMPACT SOCKETS)

DRILLING (WOOD / METAL/ MASONRY)

DRILLING / DEMOLITION (CONCRETE)

CUTTING (METAL)

MULTI TOOL ACCESSORIES

DIAMOND (CUTTING / GRINDING)

GRINDING ACCESSORIES

SANDING / POLISHING ACCESSORIES

SAWING ACCESSORIES

ROUTERS / PLANERS ACCESSORIES

CLEANERS ACCESSORIES

HEAT GUN / LASERS ACCESSORIES

BRAD NAILS/ PINS STAPLER

GARDEN TOOLS ACCESSORIES

HAND TOOLS / COMBINATION SETS

Straight Guide Assembly

A: Straight guide

B: Straight guide with micro adjustment

C: Guide Holder Assembly

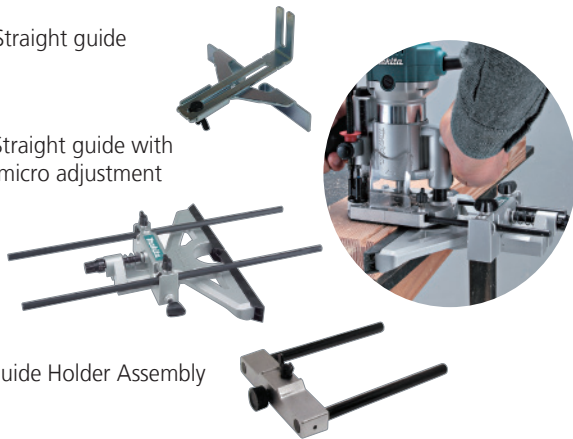

For Model	Type	Part No.
3700B, N3701, 3703, 4402	A	122391-0
3600, 3600H, 3601B	A	123029-0
3709, 3710	A	122704-5
3612BR	A	342428-9
RP0900, RP1110C, 3620	A	164834-6
3612BR, RP0900, RP0910, RP1100, RP1101, RP1800, RP2300FC, *RT0700C & DRT50	B Steel	193312-9
RP1800, RP2300FC, RP0900, RP1110C, *RT0700C & DRT50	B Aluminium	195136-9
3612BR, 3612C, 3612	C	122256-6
RP1800, RP2300FC	C	122700-3

*RT0700C & DRT50 : Use with plunge base assembly

Trimmer Guide Assembly



For Model	Part No.
3600H, 3601B, 3600	122343-1
3612BR, 3612C, 3612, RP1800, RP2300FC	123022-4
3620, RP0900, *RT0700C & DRT50	STEX122385
3709, 3710	122703-7

*RT0700C & DRT50 : Use with plunge base assembly

Guide Rail Adapter Set

A. Guide rail adapter set

B. Guide rail

C. Clamp set

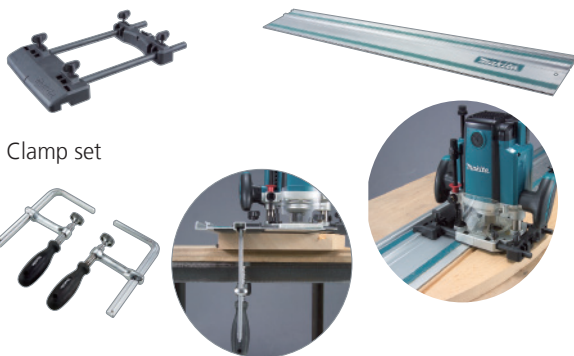

For Model	Type	Part No.
3612BR, RP0900, RP1800, RP2300FC, *RT0700C & DRT50	A	194579-2
Guide rail 1.4m	B	194368-5
Guide rail 3.1m	B	194367-7
Clamp set (2Pc)	C	194385-5

*RT0700C & DRT50 : Use with plunge base assembly

Collet Sleeve

Reduces collet size from :
12mm to 10mm, 8mm or 6mm, 1/2" to 10mm, 3/8" or 1/4".

- Available for inch collet chuck.



For Model	Size	Part No.
3600, 3600H, 3601B, 3612BR, 3612, 3612C, RP1800, RP2300FC	6mm	763801-4
	6.35mm	763808-0
	8mm	763804-8
	10mm	763807-2
	• 1/4"	763803-0
3706	• 3/8"	763805-6
	• 10mm	763806-4
3706	3.18mm	324149-5

- BATTERY / CHARGERS
- FIXING FASTENING (SCREWDRIVER BITS / IMPACT SOCKETS)
- DRILLING (WOOD / METAL / MASONRY)
- DRILLING / DEMOLITION (CONCRETE)
- CUTTING [METAL]
- MULTI TOOL ACCESSORIES
- DIAMOND (CUTTING / GRINDING)
- GRINDING ACCESSORIES
- SANDING / POLISHING ACCESSORIES
- SAWING ACCESSORIES
- ROUTERS / PLANERS ACCESSORIES
- CLEANERS ACCESSORIES
- HEAT GUN / LASERS ACCESSORIES
- BRAD NAILS/ PINS STAPLER
- GARDEN TOOLS ACCESSORIES
- HAND TOOLS / COMBINATION SETS

Collet Cone (Collet Chuck)

- Collet chuck
- Collet cone assembly

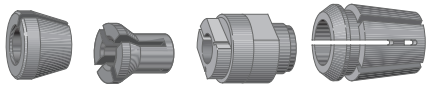

For Model	Size	Part No.
3700NB, N3701, 3703, 3704, 4402, 3606, 3706	6mm	763607-0
	6.35mm	763608-8
3709	6mm	763662-2
	12.7mm	763663-0
3710	13mm	763632-1
	12mm	763628-2
3600H, 3612BR, 3612C, 3612, RP1800 / RP2300FC	12.7mm	763622-4
	10mm	763630-5
	12mm	• 763601-2
3600, 3600BR, 3601B	12.7mm	• 763602-0
	8mm	763618-5
3620, RP0900, RT0700C, DRT50	9.5mm	763619-3
	6mm	763636-3
	6.35mm	763637-1
RP1110	6.35mm	• 193179-5
	6mm	• 193180-0
	8mm	• 193178-7

- BATTERY / CHARGERS
- FIXING FASTENING (SCREWDRIVER BITS / IMPACT SOCKETS)
- DRILLING (WOOD / METAL / MASONRY)
- DRILLING / DEMOLITION (CONCRETE)
- CUTTING (METAL)
- MULTI TOOL ACCESSORIES

Trimmer Shoe

Enables accurate chamfering and similar edge work.



For Model	Part No.
3700B, N3701, 3703, 4402	155263-4

- DIAMOND (CUTTING / GRINDING)
- GRINDING ACCESSORIES

Trimmer Base Assembly

- A. Transparent Base.
- B. For chamfering by Straight Bit.
- C. Fine depth adjustment.

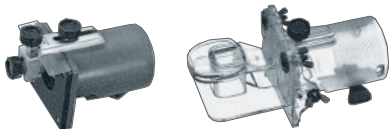

For Model	Type	Part No.
3700B, N3701, 3703, 4402	—	122202-9
	A	122238-8
3709, 3710	B	STEX122390
	—	122753-2
	B, C	194269-7

- SANDING / POLISHING ACCESSORIES
- SAWING ACCESSORIES

Sash Router Base Assembly



For Model	Part No.
3700B, N3701, 3703, 4402	JPA122201

- ROUTERS / PLANERS ACCESSORIES
- CLEANERS ACCESSORIES

Base Assembly (Attachments) for RT0700C / DRT50

- Able to meet a wide range of needs with the motor unit and the following various attachments
- Versatile system enables user to easily customize Model

Plunge base assembly

Optional fine adjusting straight guide can be used.



Part No. **195563-0**

Tilt base assembly

Tilting capacity: -30° to 45°



Part No. **195561-4**

Offset base assembly

Able to trim close to wall and tight corners with a bit set in offset position.

Distance 18.5mm from the edge to the center of bit



Part No. **195562-2**

Trimmer base assembly

Standard with the RT700C / DRT50



Part No. **196612-6**

- HEAT GUN / LASERS ACCESSORIES
- BRAD NAILS/ PINS STAPLER
- GARDEN TOOLS ACCESSORIES
- HAND TOOLS / COMBINATION SETS

Planer Blade (2pcs per pkg)

HSS (High Speed Steel planer blade).
Fine cutting surface

TCT (Tungsten Carbide Tipped planer blade).
Higher durability suitable for hard wood



* Use with set plate (343692-5)

For Model	Size (mm)	Type	Part No	New Part No (With country of origin)
1600	80	HSS	793001-2 A-07397	-
1100, N1900B/K, 1902, N1923B/K, KP0810, KP0800XK DKP180 / DKP181	82	HSS	-	D-16380 D-16346
1911B	110	HSS	793008-8 D-71211	-
1804N	136	HSS	793011-9 A-07428	-
1805N	155	TCT	793012-7	-
		HSS	D-70910	-
		TCT	793015-1	-
1806B	170	HSS	793186-4	-
2012, 2012NB	306	HSS	* 793350-7	-
		TCT	793351-5	-
2030	306	HSS	793018-5	-
	155	HSS	793014-3	-
2040	400	HSS	793019-3	-
2030N	320	HSS	793323-0	-

Mini Planer Blade (2pcs per pkg)

The blade has edges on both sides for long life.



* Use with set plate (343433-9)

For Model	Size (mm)	Type	Part No.
1100, N1900B/K, 1902, N1923B/K, KP0810, KP0800XK DKP180 / DKP181	82	TCT	* D-07945
2012, 2012NB	306	HSS	793346-8 (Disposable)

Sharpening Holder Assembly

For high speed steel blades

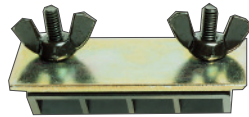

For Model	Size (mm)	Part No.
1100, N1900B/K, 1902, N1923B/K, KP0800XK, KP0810, DKP180 / DKP181	82	123004-6
1804N, 1805N, 1806B	136	123006-2
1002BA, 1911B	110	123055-9

Dressing Stone

For HSS planer blade

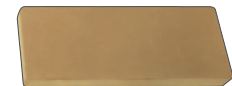

For Model	Size (mm)	Grit	Part No.
1100, N1900B/K, 1902, N1923B/K, KP0800XK, KP0810, DKP180 / 81	150	WA1200	794061-7
1804N, 1805N, 1806B	180	WA1200	794060-9

Blade Gauge Assembly

For setting up of TCT and HSS blades



For Model	Part No.
1100, N1900B/K, 1902, N1923B/K, KP0800XK, KP0810, DKP180 / DKP181	123062-2
1804N, 1805N, 1806B	123009-6
2012NB	762016-0

Edge Fence (Guide Rule)

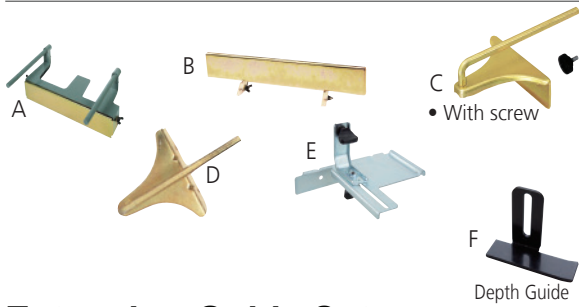

For Model	Type	Part No.
1100	A	161046-2
1100, 1600	B	123032-1
1805N	C	191454-3
N1900B, 1902, 1911B	C	191455-1
N1923B, 1923H	D	164371-0
KP0810/C	E	122785-9
DKP181, KP0810/C, N1923B, 1923H	F	342390-8

BATTERY / CHARGERS

FIXING FASTENING (SCREWDRIVER BITS / IMPACT SOCKETS)

DRILLING (WOOD / METAL/ MASONRY)

Extension Guide Set

For adding length of the fence (use with D type (Hedge fence) Guide rule & screw)

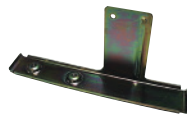

For Model	Part No.
N1900B/K, N1923B/K, 1902, 1911B, KP0800XX	191725-8

DRILLING [DEMOLITION [CONCRETE]

CUTTING [METAL]

Hood Set



For Model	Outer Dia (mm)	Part No.
2012NB	76mm	193036-7

MULTI TOOL ACCESSORIES

DIAMOND [CUTTING / GRINDING]

Nozzle Assembly

Non-clogging hip deflection in desired direction



For Model	Part No.
1804N	STEX122198
1805N	JPA122197
N1900B, N1923B	JPA122194
DKP180 / DKP181 KP0810/C, KP0800 (Elbow)	416368-8

GRINDING ACCESSORIES

SANDING / POLISHING ACCESSORIES

Planer Stand

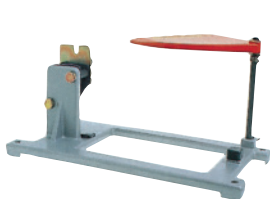

Type A
L x W x H :
442 x 271 x 450mm



For Model	Type	Part No.
1100	-	STEX122001
1805N	-	STEX122241
N1900B, 1902	-	STEX122125
1911B	-	STEX122225
N1923B	-	STEX122175
1923H	-	STEX122338
2012, 2012NB	A	193902-8

SAWING ACCESSORIES

ROUTERS / PLANERS ACCESSORIES

CLEANERS ACCESSORIES

Triangular Rule



For Model	Part No.
1600, 1923H	762001-3

HEAT GUN / LASERS ACCESSORIES

BRAD NAILS/ PINS STAPLER

Magnetic Holder

For setting of blade

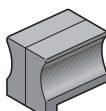

For Model	Part No.
2012, 2012NB	762014-4

GARDEN TOOLS ACCESSORIES

HAND TOOLS / COMBINATION SETS

Dust Bag Assembly

For effective chip and dust collection



For Model	Part No.
1100	STEX122312
1911B	122402-1
1923H	192268-3
1902, N1900B/K, N1923B/K	122230-4
1901	STEX122269
KP0810, KP0800XK, DKP180, DKP181	122793-0

Hex Wrench



For Model	Size (mm)	Part No.
1806B, N1923B, 1911B	4.0	783202-0
2012NB	2.5	783208-8

Socket Wrench 9



For Model	Part No.
1100, N1900B/K, 1911B, N1923B/K, 1902, 1805N, KP0810, KP0800K, DKP180, DKP181	782209-3
2012NB	782203-5



BATTERY / CHARGERS

FIXING FASTENING (SCREWDRIVER BITS / IMPACT SOCKETS)

DRILLING (WOOD / METAL / MASONRY)

DRILLING / DEMOLITION [CONCRETE]

CUTTING [METAL]

MULTI TOOL ACCESSORIES

DIAMOND [CUTTING / GRINDING]

GRINDING ACCESSORIES

SANDING / POLISHING ACCESSORIES

SAWING ACCESSORIES

ROUTERS / PLANERS ACCESSORIES

CLEANERS ACCESSORIES

HEAT GUN / LASERS ACCESSORIES

BRAD NAILS/ PINS STAPLER

GARDEN TOOLS ACCESSORIES

HAND TOOLS / COMBINATION SETS

Cutter Blade

- Carbide-tipped plate joiner blade

For Model	Dia (mm)	Bore Dia(mm)	Teeth	Tip thickness	Part No.
DPJ180, PJ7000, 3901	100	22	6	4	B-20644

BATTERY / CHARGERS

Cross-cut Saw Blade

- For smoother cross-cut work. Makes smoother cuts than combination blade.



For Model	Dia (mm)	Teeth	Tip thickness	Part No.
DPJ180, PJ7000, 3901	110	60	4mm	792012-4

FIXING FASTENING (SCREWDRIVER BITS / IMPACT SOCKETS)

DRILLING (WOOD / METAL / MASONRY)

DRILLING / DEMOLITION (CONCRETE)

Set Plate

- To center joiner blade on 12mm stock while using pivoting fence.



For Model	Part No.
DPJ180, PJ7000, 3901	415579-2

CUTTING [METAL]

MULTI TOOL ACCESSORIES

DIAMOND [CUTTING / GRINDING]

Angle Guide



For Model	Part No.
DPJ180, PJ7000, 3901	122473-8

GRINDING ACCESSORIES

SANDING / POLISHING ACCESSORIES

Biscuit (1000 pcs. in set)

- Premium quality.
- Select cut size.
- High strength.
- Finely ground edges.
- Compressed beachwood.



For Model	Type	L x W (mm)	Part No.
DPJ180, PJ7000, 3901	#0	46 x 15	P-08838
DPJ180, PJ7000, 3901	#10	54 x 19.5	P-08844
DPJ180, PJ7000, 3901	#20	56 x 23.5	P-08850

SAWING ACCESSORIES

ROUTERS / PLANERS ACCESSORIES

CLEANERS ACCESSORIES

HEAT GUN / LASERS ACCESSORIES

Lock Nut Wrench

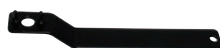

For Model	Part No.
DPJ180, PJ7000, 3901	782401-1

BRAD NAILS/ PINS STAPLER

GARDEN TOOLS ACCESSORIES

Dust Bag

- For cleaner work area



For Model	Part No.
3901	122474-6
DPJ180	123150-5

HAND TOOLS / COMBINATION SETS

- BATTERY / CHARGERS
- FIXING FASTENING (SCREWDRIVER BITS / IMPACT SOCKETS)
- DRILLING (WOOD / METAL / MASONRY)
- DRILLING / DEMOLITION [CONCRETE]
- CUTTING [METAL]
- MULTI TOOL ACCESSORIES
- DIAMOND [CUTTING / GRINDING]
- GRINDING ACCESSORIES
- SANDING / POLISHING ACCESSORIES
- SAWING ACCESSORIES
- ROUTERS / PLANERS ACCESSORIES
- CLEANERS ACCESSORIES
- HEAT GUN / LASERS ACCESSORIES
- BRAD NAILS / PINS STAPLER
- GARDEN TOOLS ACCESSORIES
- HAND TOOLS / COMBINATION SETS

Cut-out Tool Accessories

Drywall Guide Bit

A: Diamond bit



For Model	Size	Type	Part No.
3706	1/8"	-	733229-0
3706	1/4"	-	733232-1
3706	1/4"	A	A-87915
DBO181	1/8"	-	191G69-8
DBO181	1/8"	-	191G68-0
DBO181	3mm	-	193450-7

Flash Bit



For Model	Size	Part No.
DBO181	6 x 6mm	D-08218

Circular Guide



For Model	Part No.
DBO181, 3706	193448-4

Collet Sleeve

Collet sleeve for 3.8mm bit



For Model	Part No.
3706	324149-5

Collet Cone / Collet Nut



For Model	Size	Part No. Collet Cone	Part No. Collet Nut
3706	1/4"	763608-8	763606-2
DBO181	1/4"	197038-0	763675-3
DBO181	1/4"	763676-1	
DBO181	1/8"	763677-9	
DBO181	6mm	763678-7	
DBO181	3mm	763679-5	

Chain Mortiser Accessories

Cutter chain

A: Use with the sprocket (Part No. 221502-5) & chain bar (Part No. 122235-4)



For Model	Size (mm)	Type	Part No.
7104L	15	-	A-16564
	16.5	-	A-16570
	18	-	A-16586
	21	-	A-16592
	24	-	A-16601
	30	A	A-16617

Oil supply 100 mL



For Model	Part No.
7104L	182229-1

Cleaner Accessories

Hoses / Filters / Nozzles / Brushes / Dust Bag



Cleaners Attachment Chart

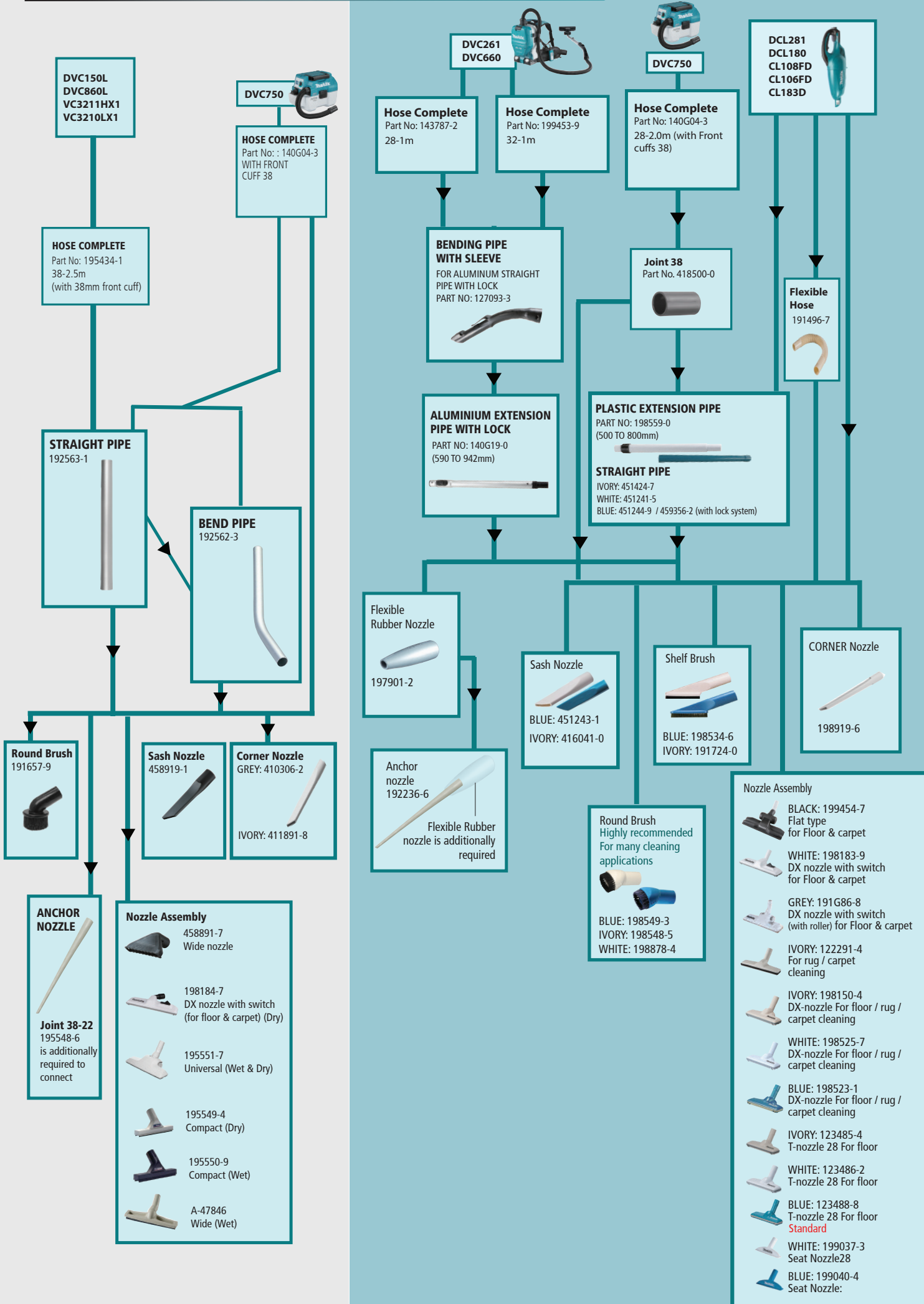

Cleaning Accessories - Hoses and pipe

Part #	DIA	CUFF DIA	LEN GTH	VC3210LX1 VC3211HX1	VC2000L	DVC150L DVC860L	DVC660	DVC261	DVC750L	DCL184 CL121D	DCL501	BATTERY / CHARGERS
143787-2	28mm	-	1.0m									
199388-4	38mm		1.5m									
199453-9	32mm	-	1.0m									
198757-6	38mm	38	1.5m									
195434-1	38mm	38	2.5m									
195435-9	38mm	38	5.0m									
140G04-3	-		2.0m									
140H92-6	-											
SH0000034	-											
P-81739												

	VC3210LX1 VC3211HX1	VC2000L	DVC150L DVC860L	DVC660	DVC261	DVC750L	DCL501	DCL281	DCL180 CL108FD CL106FD	CL183D	DIAMOND [CUTTING / GRINDING]
Straight Pipe (Aluminium) 192563-1 											
Bend Pipe (Aluminium) 192562-3 											
Straight Pipe with lock system - Extendable (Aluminium) 140G19-0 											
Straight Pipe - Extendable 198559-0 						USE WITH JOINT 38 418500-0					
Straight Pipe - Extendable SH0000060 											
Bend Pipe - with lock system 140G26-3 (without sleeve) 											
Straight Pipe with lock system 459356-2 											
Straight Pipe (Blue) 451244-9 						USE WITH JOINT 38 418500-0					
Straight Pipe (White) 451241-5 						USE WITH JOINT 38 418500-0					
Straight Pipe (Ivory) 451424-7 						USE WITH JOINT 38 418500-0					
Suction Tube P-72942 											

- BATTERY / CHARGERS
- FIXING FASTENING (SCREWDRIVER BITS / IMPACT SOCKETS)
- DRILLING (WOOD / METAL/ MASONRY)
- DRILLING / DEMOLITION (CONCRETE)
- CUTTING [METAL]
- MULTI TOOL ACCESSORIES
- DIAMOND [CUTTING / GRINDING]
- GRINDING ACCESSORIES
- SANDING / POLISHING ACCESSORIES
- SAWING ACCESSORIES
- ROUTERS / PLANERS ACCESSORIES
- CLEANERS ACCESSORIES
- HEAT GUN / LASERS ACCESSORIES
- BRAD NAILS/ PINS STAPLER
- GARDEN TOOLS ACCESSORIES
- HAND TOOLS / COMBINATION SETS

Brushes

		VC3210LX1 VC3211HX1 DVC150L / 860L	DVC750L	VC2000L	DCL184 CL121D	DVC660	DVC261	DCL281	DCL180 CL108FD CL106FD	CL183D	DCL501	
												BATTERY / CHARGERS
Round Brush - help loosen debris for a deeper clean	191657-9 	•	•									FIXING FASTENING (SCREWDRIVER BITS / IMPACT SOCKETS)
	198548-5 					•	•	•	•	•		DRILLING (WOOD / METAL / MASONRY)
	198549-3 					•	•	•	•	•		DRILLING / DEMOLITION (CONCRETE)
	198878-4 NEW 					•	•	•	•	•		CUTTING (METAL)
Shelf Brush	191724-0 		Used with joint 418500-0			•	•	•	•	•		MULTI TOOL ACCESSORIES
	198534-6 						•	•	•	•	•	
Sash nozzle	416041-0 					•	•	•	•	•		DIAMOND (CUTTING / GRINDING)
	451243-1 					•	•	•	•	•		DIAMOND (CUTTING / GRINDING)
	458919-1 	•	•									GRINDING ACCESSORIES
Corner nozzle	410306-2 	•	•									SANDING / POLISHING ACCESSORIES
	411891-8 	•	•									SANDING / POLISHING ACCESSORIES
	198919-6 NEW 			Used with joint 418500-0		•	•	•	•	•		SAWING ACCESSORIES
	P-72942 NEW 				•							SAWING ACCESSORIES
	SH00000042 										•	ROUTERS / PLANERS ACCESSORIES
Flexible Rubber Nozzle	197901-2 					•	•	•	•	•		CLEANERS ACCESSORIES
Anchor nozzle	192236-6 	Used with front cuff 22+hose28mm	Used with joint 418500-0 + 197901-2			Used with Flexible rubber nozzle 197901-2						HEAT GUN / LASERS ACCESSORIES
Soft brush	140H94-2 				•							HEAT GUN / LASERS ACCESSORIES
Corner nozzle	422437-5 				•							BRAD NAILS/ PINS STAPLER
Blower nozzle	140J64-3 				•							BRAD NAILS/ PINS STAPLER
Flexible hose	191496-7 						•		•	•		GARDEN TOOLS ACCESSORIES
Hose Stand	197323-6 	•										HAND TOOLS / COMBINATION SETS
Hose Clip	195544-4 	•										HAND TOOLS / COMBINATION SETS

- BATTERY / CHARGERS
- FIXING FASTENING (SCREWDRIVER BITS / IMPACT SOCKETS)
- DRILLING (WOOD / METAL / MASONRY)
- DRILLING / DEMOLITION [CONCRETE]
- CUTTING [METAL]
- MULTI TOOL ACCESSORIES
- DIAMOND [CUTTING / GRINDING]
- GRINDING ACCESSORIES
- SANDING / POLISHING ACCESSORIES
- SAWING ACCESSORIES
- ROUTERS / PLANERS ACCESSORIES
- CLEANERS ACCESSORIES
- HEAT GUN / LASERS ACCESSORIES
- BRAD NAILS/ PINS STAPLER
- GARDEN TOOLS ACCESSORIES
- HAND TOOLS / COMBINATION SETS

CLEANING SET

195439-1

Straight pipe, Bend pipe, Nozzle assembly, Corner nozzle, 38mm Hose - 2.5m with cuff 38mm
For model DVC154L, DVC150L, DVC184L, DVC180L, VC3210LX1, VC3211HX1



Filters and dust bags

	DVC660 DVC665	DVC261 DVC265
Main filter H set (HEPA Filter)	191D12-9 NEW	123636-9
Filter bag set (Paper dust bag)	191C26-2 NEW 10PCS	197903-8 10PCS
Dust bag assembly (Cloth type)	191C30-1 NEW	197898-5

Filters and dust bags

	DVC350	DCL184 CL121D
Dust bag	122918-6	194566-1 5PCS
Valve stay complete		143677-9
Sponge sheet		422440-6





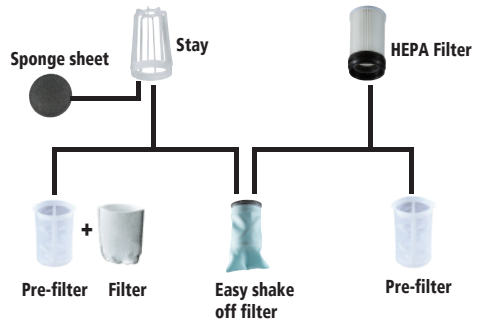

























Filters and dust bags

DCL281, DCL180, CL108FD, CL106FD, CL183D



HEPA Filter	199989-8 NEW	
Pre-Filter	451208-3	
	198750-0 (with package & country of origin) NEW	
Easy shake-off filter	199966-0 NEW	
Filter	443060-3	
Stay (Filter flame)	458467-0	
Sponge sheet	422268-2 (not suitable for CL183D)	

Filters and dust bags

	DVC154L DVC860L (Wet & Dry)	DVC150L DVC864L (Dry)	VC3211H (Wet & Dry)	VC3210L	DVC750L (Dry)	VC2000L	
Used as a set	Powder Filter Set (Dry only) *HEPA filter	*197166-6 	*197166-6 	196251-2 	195441-4 	*162518-0 	
	Pre-filter set	195553-3 	195553-3 	196253-8 	195612-3 	162635-6 	
	Damper set	195552-5 	195552-5 	196254-6 	195552-5 	422449-8 	
Cloth filter	140248-3 						
Water filter (Wet only)	195555-9 			195611-5 			
Filter bag set (For dry dust)	195557-5 15L / 5PCS 	195557-5 15L / 5PCS 	195558-3 25L / 5PCS 	195558-3 25L / 5PCS 			
PAPER FILTER (For dry dust except powder)	A-48430 10PCS 	A-48430 10PCS 					
Poly bag set	195432-5 10PCS 	195432-5 10PCS 	195440-6 10PCS 	195440-6 10PCS 			
Disposable bag						P-70297 NEW 5PCS 	
Filter bag						P-72899 NEW 5PCS 	

BATTERY /
CHARGERS

FIXING FASTENING
(SCREWDRIVER BITS
/ IMPACT SOCKETS)

DRILLING
(WOOD / METAL/
MASONRY)

DRILLING
/ DEMOLITION
(CONCRETE)

CUTTING
(METAL)

MULTI TOOL
ACCESSORIES

DIAMOND
(CUTTING / GRINDING)

GRINDING
ACCESSORIES

SANDING
/ POLISHING
ACCESSORIES

SAWING
ACCESSORIES

ROUTERS
/ PLANERS
ACCESSORIES

CLEANERS
ACCESSORIES

HEAT GUN / LASERS
ACCESSORIES

BRAD NAILS/ PINS
STAPLER

GARDEN TOOLS
ACCESSORIES

HAND TOOLS /
COMBINATION SETS

- BATTERY / CHARGERS
- FIXING FASTENING (SCREWDRIVER BITS / IMPACT SOCKETS)
- DRILLING (WOOD / METAL / MASONRY)
- DRILLING / DEMOLITION (CONCRETE)
- CUTTING [METAL]
- MULTI TOOL ACCESSORIES
- DIAMOND [CUTTING / GRINDING]
- GRINDING ACCESSORIES
- SANDING / POLISHING ACCESSORIES
- SAWING ACCESSORIES
- ROUTERS / PLANERS ACCESSORIES
- CLEANERS ACCESSORIES
- HEAT GUN / LASERS ACCESSORIES
- BRAD NAILS/ PINS STAPLER
- GARDEN TOOLS ACCESSORIES
- HAND TOOLS / COMBINATION SETS

Cyclone attachment

Cyclonic Vacuum Attachment is designed to expand the capacity to collect debris.

- Powerful cyclonic action captures up to 90% of dust particles before entering the main dust box
- Reduces the frequency of emptying the main dust box
- One-touch release for easy disposal of debris



Part # 191D71-3

With lock system (for stick type cleaners & Backpack cleaners with lock system)



Part # 199491-1

Without lock system (for stick type cleaners Backpack cleaners without lock system)



Wall Bracket

Easy Storage with Vacuum Wall Mount Bracket
Get the convenient storage



Part # 199971-7

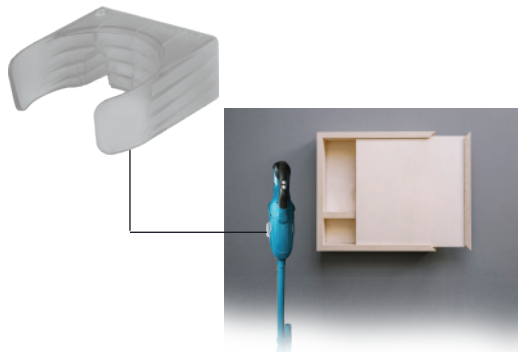

- Accepts all 18V LXT hand vacuums
- Durable construction of high quality materials for long life
- Improved front cover design for easy dust bag removal.

Front Cuffs / Joints

38	22	24	22-38
Dia 38mm	Dia 22mm	Dia 24mm	Dia 22mm
Thread type: Fit with 28mm Hose	Thread type: Fit with 28mm Hose	Rubber Type can fix with 38 & 22mm cuffs	Fit with front cuff 38
Part No 195545-2	Part No 195547-8	Part No 195546-0	Part No 195548-6

Battery Adapter

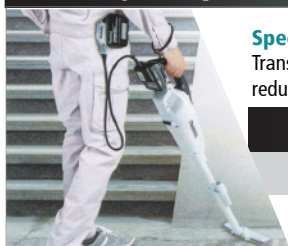

Specially designed for use with 18V LXT cordless cleaners

Transfers the battery weight from the cleaner to user's waist to reduce the stress on hand

Type	Part no
BAP18C	191M50-5



WUT02 - AWS Adapter for AC Cleaners

- Enables wireless On/Off communication of Makita AWS capable tools with AC Dust Extractors that include a tool-activated power outlet
- Allows communication between battery operated tools and extractor to eliminate cords, increase productivity, and reduce noise
- Includes an adaptable hanging hook and strap for easy attachment to multiple extractors



WUT02
Part#: 199838-9



Channel setting button is used to test the successful pairing of the tool and extractor

Caution Lamp lights up red if adapter is overheating or other malfunction occurs



Wireless unit (Bluetooth chip)
Part#: 198900-7 (optional)



Auto-start wireless system enables the Dust Extractor runs automatically



WUT02 Auto-Star Wireless Adapter

AC Vacuum Cleaner VC3210LX1 / VC3211HX1

Hoses for dust collecting

Hose		Type a: Removable: front cuff can be removed and interchangeable with 22 and 38 front cuffs Type b: Front cuff is fixed with hose and cannot be removed		Type a Cuffs can be detachable	Type b fixed cuff	
Hose length (m)	Hose Dia	With Front Cuffs	Type	Recommended for Vacuum Cleaners	Part No	Standard Equipments for Vacuum Cleaners
1.5m	28mm	38	a	DVC265X	152992-0	DVC265X / DVC665
1.5m	28mm	22, 38	a	VC3211HX1, VC3210LX1, DVC860L, DVC864L, DVC265X,	A-34235	
2.5m	38mm	38	b	VC3211HX1, VC3210LX1, DVC860L	195434-1	VC3211HX1, VC3210LX1, DVC860L / 150L
2.5m	28mm	22, 24, 38	a	VC3211HX1, VC3210LX1, DVC860L, DVC864L, DVC265X	195437-5	
3.5m	28mm	22, 24, 38	a	VC3211HX1, VC3210LX1, DVC860L, DVC864L, DVC265X	195433-3	VC3211HX1, VC3210LX1, DVC864L / 154L
5m	28mm	22, 24, 28	a	VC3211HX1, VC3210LX1, DVC860L, DVC864L, DVC265X	195436-7	
-	38mm	38	b	DVC750L	140G04-3	DVC750L
5m	38mm	38	b	VC3211HX1, VC3210LX1, DVC860L	195435-9	

406, 407, 440 - Vacuum Cleaner Hoses

Hoses



■ Standard equipment

For Vacuum Model	Type	Vacuum Fitting		Attachment Fitting		Hose length	Part No.
		Inner dia (mm)	Outer dia (mm)	Inner dia (mm)	Outer dia (mm)		
406, 407	a	± 44	± 48	± 38	± 44	2.5 m	■ 193326-8
406, 407	a	± 44	± 48	± 38	± 44	5.0 m	193328-4
440	b	± 54	± 60	± 38	± 44	1.5 m	01317B0N
440	b	± 54	± 60	± 38	± 44	2.0 m	■ 01316B0N for vacuum attachment
440	c	± 54	± 60	± 28	± 32	3.0 m	■ 01321B0N for tools attachment

Additional Hoses	Type	Tool Fitting		Hose to Hose Fitting		Hose length	Part No.
		Inner dia (mm)	Outer dia (mm)	Inner dia (mm)	Outer dia (mm)	Meter	
Extremely flexible for connecting to small tools	d	± 19	± 25	± 32	± 38	2.5 m	192108-5
Semi Rigid hose similar to hose supplied with 407/440	e	± 22	± 25	± 30	± 38	1.5 m	192278-0
	e	± 22	± 25	± 30	± 38	3.0 m	192279-8

Attaches directly to 407/440 38mm standard equipment hoses

BATTERY / CHARGERS

FIXING FASTENING (SCREWDRIVER BITS / IMPACT SOCKETS)

DRILLING (WOOD / METAL / MASONRY)

DRILLING / DEMOLITION (CONCRETE)

CUTTING (METAL)

MULTI TOOL ACCESSORIES

DIAMOND (CUTTING / GRINDING)

GRINDING ACCESSORIES

SANDING / POLISHING ACCESSORIES

SAWING ACCESSORIES

ROUTERS / PLANERS ACCESSORIES

CLEANERS ACCESSORIES

HEAT GUN / LASERS ACCESSORIES

BRAD NAILS/ PINS STAPLER

GARDEN TOOLS ACCESSORIES

HAND TOOLS / COMBINATION SETS





















- BATTERY / CHARGERS
- FIXING FASTENING (SCREWDRIVER BITS / IMPACT SOCKETS)
- DRILLING (WOOD / METAL / MASONRY)
- DRILLING / DEMOLITION [CONCRETE]
- CUTTING [METAL]
- MULTI TOOL ACCESSORIES
- DIAMOND [CUTTING / GRINDING]
- GRINDING ACCESSORIES
- SANDING / POLISHING ACCESSORIES
- SAWING ACCESSORIES
- ROUTERS / PLANERS ACCESSORIES
- CLEANERS ACCESSORIES
- HEAT GUN / LASERS ACCESSORIES
- BRAD NAILS/ PINS STAPLER
- GARDEN TOOLS ACCESSORIES
- HAND TOOLS / COMBINATION SETS

406, 407, 440 - Vacuum Cleaner Nozzles, Pipes and Filters

For Model	Type		Part No.
406, 407	Nozzle assembly	Standard Equipment	122512-4
406, 407		Compact type (wet)	122334-2
406, 407		Compact type (wet)	122335-0
4072D		Floor Nozzle	122520-5
440		Enables liftig of liquids (for carpets)	60278B0N
440		Straight Pipe	60277B0N
440		Pipe / Nozzle	Triangular Head Nozzle
440	Crevice Nozzle (size 45mm)		50089B0N
440	Multi Use brush (for Hard floors, concrete, tiles, carpets)		50080B0N
406, 407	Filter	Paper Filter (5pcs)	A-48430
406, 407		Nylon Filter Set	192605-1
440		Sponge Filter (for wet applications)	83035BHB
406, 407		Powder Filter (Dry type)	A-33548
440		Powder Filter (Dry type)	83203BJA

High Pressure Washer accessories for HW1200, HW1300



Type	Part No.	Type	Part No.
 Trigger gun set 197842-2		 Foam nozzle set 197886-2	
 Variable nozzles 197822-8		 Pipe cleaning hose 10m 197837-5	
 Various spray lance set 197876-5		 High pressure extension hose 15m 197840-6	
 Cyclone jet nozzle set 197824-4		 High pressure extension hose 5m 197845-6	
 Cyclone guard set 197864-2		 High pressure extension hose 8m 197847-2	
 Under body spray lance set (for 220V-240V) 198909-9		 High pressure extension hose 10m 197850-3	
 Extension pipe set 0.9m 1.3m 1.7m 197870-7		 Twist prevention joint set 197867-6	
 Rotating brush set 197831-7		 Self suction hose set 197873-1	
 Wash brush set 197828-6		 Accessory joint set 197853-7	
		 Absorption connector set 197881-2	
		 One touch joint set 197883-8	
		Cleaner pin set 197879-9	



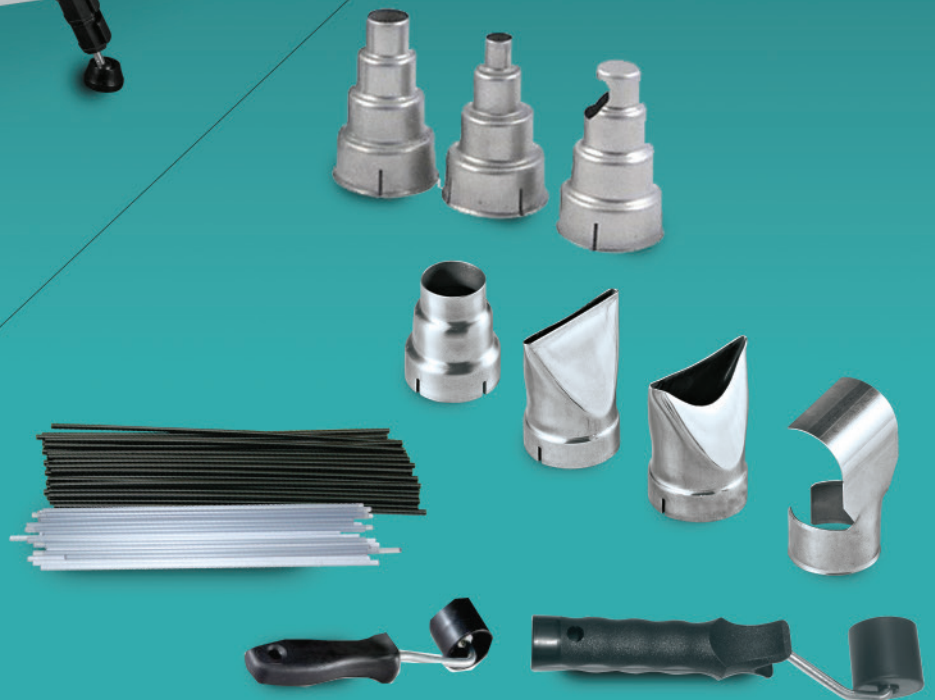

Heat Gun / Laser Accessories





Nozzles / Tripod













Heat Gun Accessories

For models : HG6030K / HG6531CK / HG6530V



Shape	Part No.
Glass protection nozzle 	PR00000028
Wide - slot nozzle 	PR00000029
Reflector nozzle 	PR00000030
Reduction nozzle 20 	PR00000031

Shape	Part No.
Overlap welding nozzle 	PR00000032
Solder sleeves reflector 	PR00000033
Welding nozzle 	PR00000034
Speed welding nozzle 	PR00000039

For models : HG6020 / HG651C/K, HG5012/K, HG1100, HL500

	Part no.	HG6020	HG651C/K	HG5012/K	HG1100	HL500
Reflector Nozzle 	53155000 103155000	●			●	●
	P-71445 		●	●		
Reduction Nozzle 	103155100	●			●	
	P-71439 		●			
Welding Nozzle 	53155200 103155200				●	
	P-71451 		●			
Soldering Reflector Nozzle 	53155300 103155300				●	
Surface Nozzle 75mm 	103154900	●			●	●
Glass Protection Nozzle 	P-71417		●	●		
Wide-slot Nozzle 	P-71423		●	●		
Overlap Welding Nozzle 	P-71489		●			

Pressure Roller and Plastic welding Rod (Universal)

Shape	Part No.
Pressure Roller 	P-33738
Pressure roller 	PR00000035

Shape	Part No.	
Plastic Welding Rod 	PVC Plastic	103154700
	ABS Plastic	53154800 103154800

- BATTERY / CHARGERS
- FIXING FASTENING (SCREWDRIVER BITS / IMPACT SOCKETS)
- DRILLING (WOOD / METAL / MASONRY)
- DRILLING / DEMOLITION (CONCRETE)
- CUTTING [METAL]
- MULTI TOOL ACCESSORIES
- DIAMOND [CUTTING / GRINDING]
- GRINDING ACCESSORIES
- SANDING / POLISHING ACCESSORIES
- SAWING ACCESSORIES
- ROUTERS / PLANERS ACCESSORIES
- CLEANERS ACCESSORIES
- HEAT GUN / LASERS ACCESSORIES
- BRAD NAILS/ PINS STAPLER
- GARDEN TOOLS ACCESSORIES
- HAND TOOLS / COMBINATION SETS

Laser Accessories

Tripod

(Aluminium)



Max Height 1.65m



Max Height 2.70m

Type	Max Height	Part No.
Standard Tripod - Flat head	1.65 Meter	P-46361
Tripod with Elevating Column	2.70 Meter	P-46399

Aluminium Rod



Description	Size	Part No.
Aluminium Rod	4 Meter	P-46414

Detector for SKR301



Type	Part No.
LD 150A Detector	P-67876

Magnetic Target for SKR301

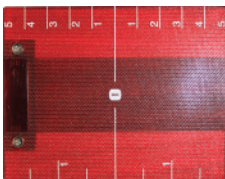

Type	Part No.
CB60 Magnetic Target	P-66531

Wall mount

With fine adjustment

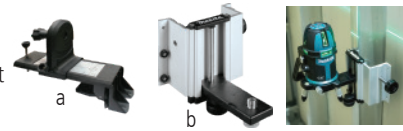

For Model	Type	Part No.
SKR301	a	791661S
SK312GD	b	TK000ET03F

Power supply cable

Helps to connects the Laser and the adapter ADP05



For Model	Part No.
SK312GD	199006-4
SK106GD, SK106D, SK105GD, SK105D	199178-5

Hand strap set



For Model	Part No.
SK312GD	199007-2

Green Beam Laser Detector LDG-3



- Capable of detecting horizontal and vertical laser lines up to a distance of 65 feet
- Laser detection is indicated by red/green/orange light indicators and sound buzzers
- Auto power-off for increased battery power conservation
- Dust and water resistance

For Model	Part No.
SK312GD	TK0LDG301F

BATTERY / CHARGERS

FIXING FASTENING (SCREWDRIVER BITS / IMPACT SOCKETS)

DRILLING (WOOD / METAL / MASONRY)

DRILLING / DEMOLITION (CONCRETE)

CUTTING [METAL]

MULTI TOOL ACCESSORIES

DIAMOND [CUTTING / GRINDING]

GRINDING ACCESSORIES

SANDING / POLISHING ACCESSORIES

SAWING ACCESSORIES

ROUTERS / PLANERS ACCESSORIES

CLEANERS ACCESSORIES

HEAT GUN / LASERS ACCESSORIES

BRAD NAILS/ PINS STAPLER



GARDEN TOOLS ACCESSORIES

HAND TOOLS / COMBINATION SETS

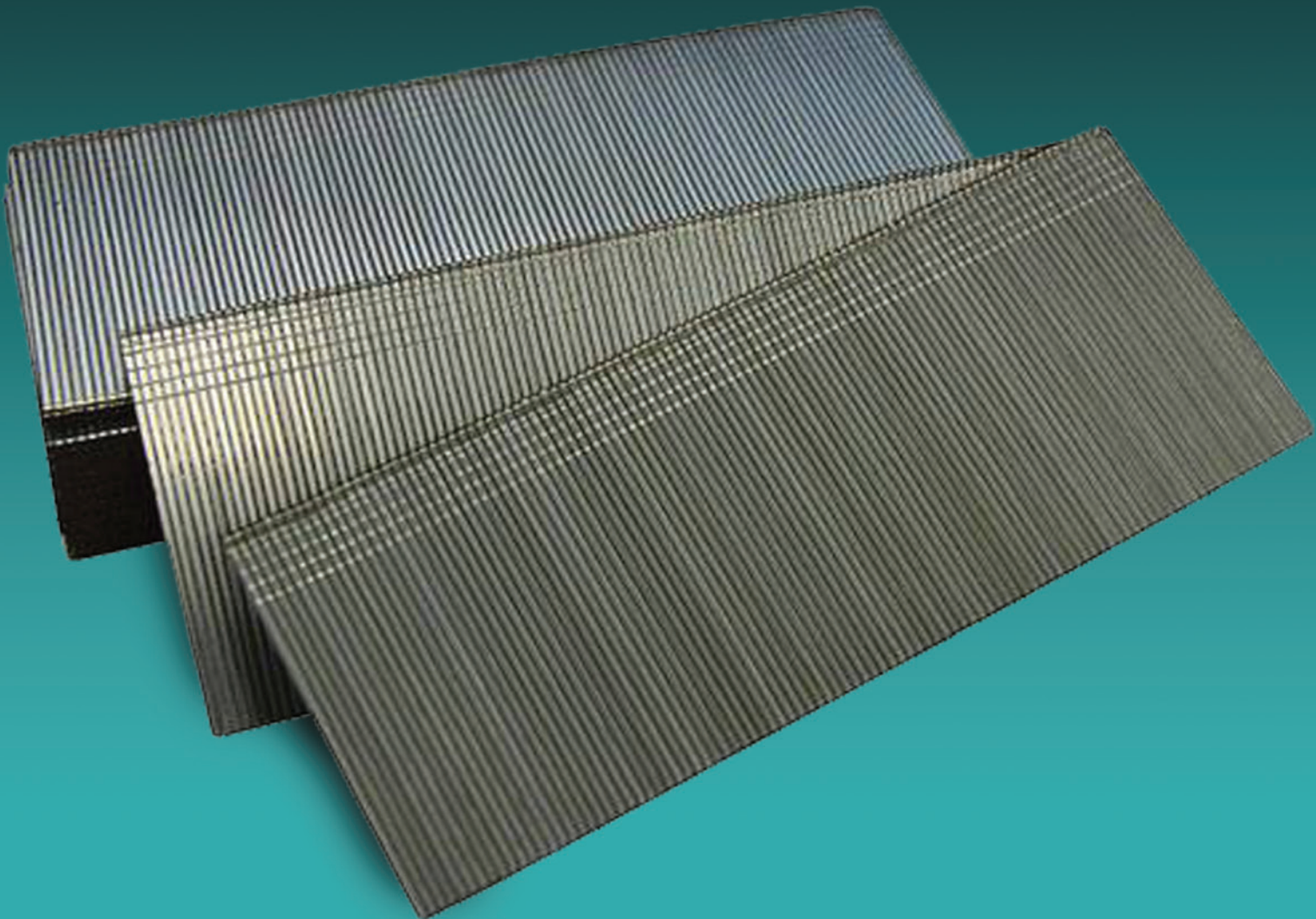
Staples / Pin Nails / Brad Nails

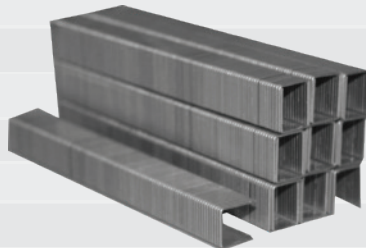
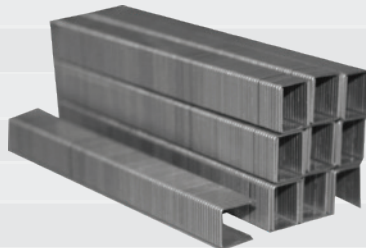
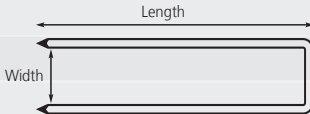

Staples

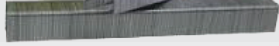
For Model		W X L (mm)	Pcs/Pkg	Part No.
AT425B		4 x 10	5,000	B-04400
		4 x 13		B-04416
		4 x 16		B-04422
		4 x 19		B-04438
		4 x 22		B-04444
		4 x 25		B-04450
AT1025B		10 x 10	5,000	B-04466
		10 x 13		B-04472
		10 x 16		B-04488
		10 x 19		B-04494
		10 x 22		B-04503
		10 x 25		B-04519
AT1225BZ		12 x 10	5,000	B-04525
		12 x 12		B-04531
		12 x 14		B-04547
		12 x 16		B-04553
		12 x 18		B-04569
		12 x 20		B-04575
		12 x 25		B-04581
For Model		W X L (mm)	Pcs/Pkg	Part No.
DST221Z		10 x 10	5,040	F-32647
		10 x 13		F-32650
		10 x 16		F-32663
		10 x 19		F-32676
		10 x 22		F-32689
DST112, ST113D		7 x 10	25,000	F-81518
		10 x 10	15,000	F-81521

Driving depth adjustment

Driving depth is adjustable by installing the optional Adjuster set

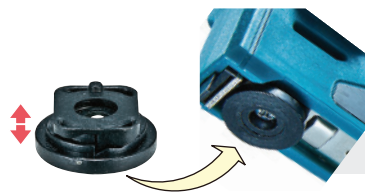

For Model

DST112, ST113D

Part No.

197731-1

BATTERY /
CHARGERS

FIXING FASTENING
(SCREWDRIVER BITS
/ IMPACT SOCKETS)

DRILLING
(WOOD / METAL/
MASONRY)

DRILLING
/ DEMOLITION
(CONCRETE)

CUTTING
(METAL)

MULTI TOOL
ACCESSORIES

DIAMOND
(CUTTING / GRINDING)

GRINDING
ACCESSORIES

SANDING
/ POLISHING
ACCESSORIES

SAWING
ACCESSORIES

ROUTERS
/ PLANERS
ACCESSORIES

CLEANERS
ACCESSORIES

HEAT GUN / LASERS
ACCESSORIES

BRAD NAILS/ PINS
STAPLERS

GARDEN TOOLS
ACCESSORIES

HAND TOOLS /
COMBINATION SETS

- BATTERY / CHARGERS
- FIXING FASTENING (SCREWDRIVER BITS / IMPACT SOCKETS)
- DRILLING (WOOD / METAL / MASONRY)
- DRILLING / DEMOLITION (CONCRETE)
- CUTTING [METAL]
- MULTI TOOL ACCESSORIES
- DIAMOND [CUTTING / GRINDING]
- GRINDING ACCESSORIES
- SANDING / POLISHING ACCESSORIES
- SAWING ACCESSORIES
- ROUTERS / PLANERS ACCESSORIES
- CLEANERS ACCESSORIES
- HEAT GUN / LASERS ACCESSORIES
- BRAD NAILS / PINS STAPLERS
- GARDEN TOOLS ACCESSORIES
- HAND TOOLS / COMBINATION SETS

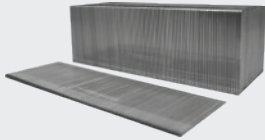
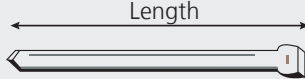

Brad Nails

For Model		Length (mm)	Pcs/Pkg	Part No.
AF301 DFN350, AF506		15	5,000	B-04307
		20		B-04313
		25		B-04329
		30		B-04335
DFN350, AF506		35		B-04357
AF506		40		B-04379
		45		B-04385
		50		B-04391

Pin Nails

For Model		Length (mm)	Pcs/Pkg	Part No.
AF201Z, DPT351, DPT353, PT354D		18mm	10,000	F-31825
AF201Z, DPT351, DPT353, PT354D		25mm		F-31838
DPT351Z, DPT353, PT354D		30mm		F-31841
DPT351Z, DPT353, PT354D		35mm		F-31854

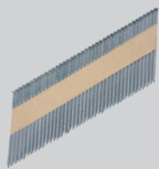
Coil Nails

For Model			Dia (mm)	Length (mm)	Pcs/Pkg	Part No.
AN613 		Smooth	2.5 mm	45mm	10,800	F-30810
		Screw Chisel	2.5 mm	50mm	10,800	F-30865
		Smooth	2.5 mm	50mm	10,800	F-31243
		Screw Chisel	2.5 mm	57mm	8,100	F-30878
		Smooth	2.5 mm	57mm	8,100	F-31256
		Smooth	2.5 mm	65mm	8,100	F-30900
		Screw Chisel	2.5 mm	65mm	8,100	F-31269



Garden Tools Accessories

Saw Chain, Trimmer Blade, Nylon Brush, Brush Cutter Blades, Blower Accessories, Oil



Multi Function Power Head attachments

- Able to meet a wide range of needs with only one power head
- Same accessories as used for EX2650LH

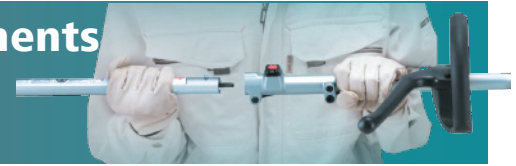

Brush cutter EM400MP (Part no: 195654-7)



The lower section for nylon cutting head can be removed without tool.

Bump & feed 4
Cutting width : 420mm
Dimensions: 876x374x211mm
Net weight : 1Kg

Standard Equipments:
Nylon cutting head
Hex wrench 5



String trimmer ER400MP (Part no: 195528-2)



Bump & feed 4
Dimensions: 703x270x402mm
Net weight : 0.5Kg

Standard Equipments:
Nylon cutting head
Socket wrench 10-16



Ground trimmer EN420MP (Part no: 198060-5)



Suitable for undergrowth mowing that requires special attention for flying stone or kickback

Max cutting capacity: 250mm
Dimensions: 1,324x104x103mm
Net weight : 2.6kg

Standard Equipments:
Blade cover Socket wrench



Pole Hedge Trimmer (Angle) EN401MP Part no: 196342-9

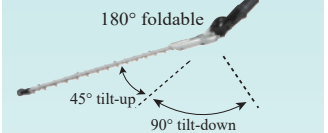

Max cutting capacity: 490mm
Teeth: 3 sharpened edges

Thickness : 2mm
Tooth spacing: 35mm
Max branch diameter: 21.5mm
Dimensions: 1,624 x 108 x 90mm
Net weight: 2.7Kg

Standard Equipments:
Blade cover, Socket wrench 10



Pole Hedge Trimmer (Straight) EN410MP Part no: 197740-0

Lighter and cost effective than angle adjustable hedge trimmer attachment



Max cutting capacity: 490mm
Teeth: 3 sharpened edges
Thickness : 2mm
Tooth spacing: 35mm
Max branch diameter: 22mm
Strokes per minute: 4200 - 4100spm
Dimension: 1,104 x 85-71 x 61mm
Net weight: 1.8Kg

Standard Equipments:
Blade cover, Socket wrench 10



Cultivator KR400MP (Part no: 195713-7)

6pcs - Cleaver-shape claw



Excellent for cultivating small garden beds and between rows of vegetables or flowers

Cultivating width: 160mm
Outer dia : 232mm
Dimensions: 965x235x264mm
Net weight : 2.9Kg

Standard Equipments:
Hex wrench 5, Torx Wrench



Cultivator KR401MP (Part no: 199188-2)

6pcs - Cleaver-shape claw



Excellent for cultivating small garden beds and between rows of vegetables or flowers

Cultivating width: 220mm
No load speed: 230rpm
Dimensions: 965x235x256mm
Net weight : 3.2Kg

Standard Equipments:
Torx Wrench

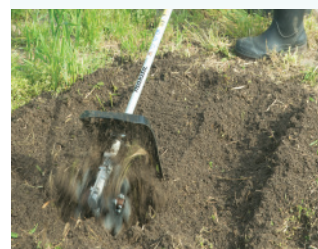

Pole saw EY401MP (Part no: 196104-5)



Chain oil tank: 0.11L
Guide bar length: 255mm
Dimensions: 1,166x80x120mm
Net weight : 1.1kg

Standard Equipments:
Wrench 8-10, Hex wrench 4
Guide bar cover



BATTERY / CHARGERS

FIXING FASTENING (SCREWDRIVER BITS / IMPACT SOCKETS)

DRILLING (WOOD / METAL / MASONRY)

DRILLING / DEMOLITION (CONCRETE)

CUTTING (METAL)

MULTI TOOL ACCESSORIES

DIAMOND (CUTTING / GRINDING)

GRINDING ACCESSORIES

SANDING / POLISHING ACCESSORIES

SAWING ACCESSORIES

ROUTERS / PLANERS ACCESSORIES

CLEANERS ACCESSORIES

HEAT GUN / LASERS ACCESSORIES

BRAD NAILS/ PINS STAPLER

GARDEN TOOLS ACCESSORIES

HAND TOOLS / COMBINATION SETS

**Power Sweeper
SW400MP**

Part no: 199347-8

- Sweeping dust, fallen leaves, or snow on the ground
- If the ground is hard and flat, water can be swept away from the surface

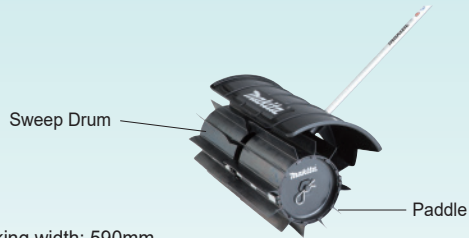

Working width: 590mm
No Load Speed: 230rpm
Outer diameter of Sweep drum: 265mm
Number of Paddle: 12
Dimension (L x W x H): 1,159 x 600 x 362mm
Net weight: 7.2Kg

Standard Equipments: Torx wrench



**Power Brush
BR400MP**

Part no: 199326-6

Cleaning of pavement with many joints and uneven stones using nylon brush

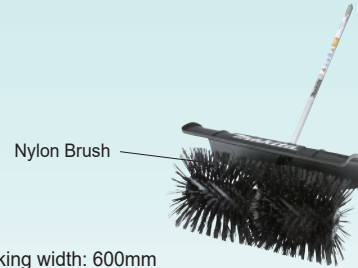

Working width: 600mm
No Load Speed: 230rpm
Outer diameter of Brush: 250mm
Dimension (L x W x H): 1,159 x 600 x 362mm
Net weight: 7.2Kg

Standard Equipments: Torx wrench



BATTERY /
CHARGERS

FIXING FASTENING
(SCREWDRIVER BITS
/ IMPACT SOCKETS)

DRILLING
(WOOD / METAL/
MASONRY)

DRILLING
/ DEMOLITION
(CONCRETE)

CUTTING
(METAL)

MULTI TOOL
ACCESSORIES

DIAMOND
(CUTTING / GRINDING)

GRINDING
ACCESSORIES

**Edger
EE400MP**

(Part no: 196752-0)



Blade dia : 203mm
Dimensions: 878x131x291mm
Net weight : 2.4Kg

Standard Equipments:
Hex wrench 5, Torx Wrench

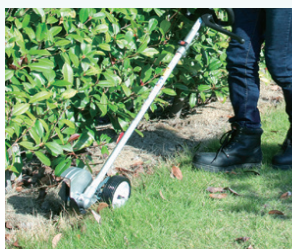

**Blower
UB400MP**

Part no: 191F72-3

For High power blowing



Blowing force: 0-14.2N
Air volume: 0-14.6m³/min
Air speed (max): 0-60.4 m/sec
No load speed: min-1= 0-8,700rpm
Weight: 1.7kg



**Shaft extension
attachment
LE400MP**

Part no: 196032-4



For Pole saw & For Pole hedge trimmer
Extension Length: 1,080mm
Dimensions: 1,157x80x80mm
Net weight : 1.3kg

SANDING
/ POLISHING
ACCESSORIES

SAWING
ACCESSORIES

ROUTERS
/ PLANERS
ACCESSORIES

CLEANERS
ACCESSORIES

HEAT GUN / LASERS
ACCESSORIES

BRAD NAILS/ PINS
STAPLER

GARDEN TOOLS
ACCESSORIES

HAND TOOLS /
COMBINATION SETS

Saw Chain and Guide Bar

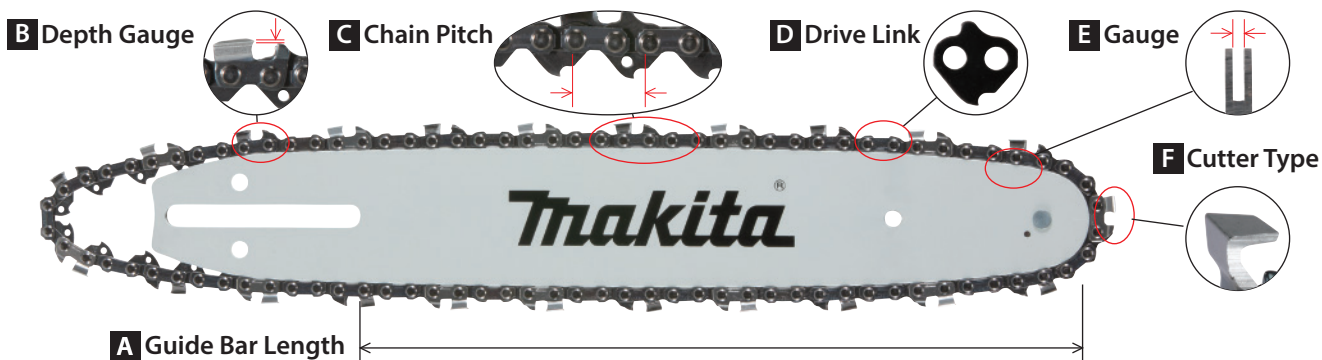

A Guide Bar Length

Guide bar's length is represented by the cutting length, which is different from its total length.



B Depth Gauge

Depth gauge means the gap between the top of the depth gauge and the top of the cutter and determines how deep the cutting teeth get into the wood.

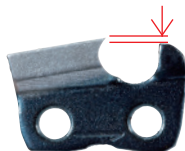

C Chain Pitch

Chain pitch is the size of the chain, and is defined as the distance between any three consecutive rivets divided by two. Pitch is important because the drive sprocket must be the same pitch as the chain.



D Drive Link

The length of saw chain is determined by counting the number of drive links in the saw chain.

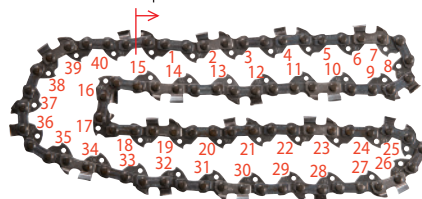

E Gauge

Chain Gauge is the drive link's thickness where it fits into the guide bar groove, matching the guide bar gauge. The gauge of the chain and the gauge of the bar must match.

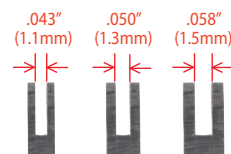

F Cutter Type

	MICRO CHISEL	SEMI CHISEL	CHAMFER CHISEL	FULL CHISEL
Abbreviation	MC	SC	CC	FC
End View				

Guide Bar Type

Sprocket Nose Bars

Sprocket nose bars have a rotating sprocket mounted on at the tip of the bar. As the chain moves along the bar, the sprocket teeth carry the chain around the tip smoothly with less friction.



Hard Nose Bars (Solid Bar)

High wear resistant stellite is welded onto the tip. Hard nose bars are made for difficult situation, including fire-damaged forests, deserts, or sandy environments.



Carving Bars

Carving bars are made of high-quality steel and high wear resistant stellite is welded onto the tip. The small nose radius is designed for precision cutting. The carving bars are made for especially pruning and carving.



Guide Bar Maintenance

Chain Tension

From time to time the saw chain tension before use. The saw chain may become loose after many hours of use.



File Bar Edge

File bar edge with a flat file to keep 90° once a week.



Clean Guide Bar

Clean out the chips and sawdust every time when you sharpen or replace the saw chain



Bar Nose Grease

Lubricate a whole sprocket regularly to make sure that the saw chain can rotate with less friction.

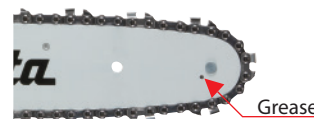

Sharpening Saw Chain

Round File and File holder



The file can be guided more easily if a file holder is employed. The file holder has markings for the correct sharpening angle of 30° (align the markings parallel to the saw chain) and limits the depth of penetration (to 4/5 of the file diameter).

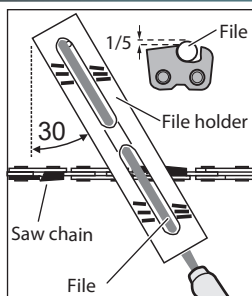

Depth gauge jointer

After sharpening the chain, check the height of the depth gauge using the chain gauge tool.



Flat file

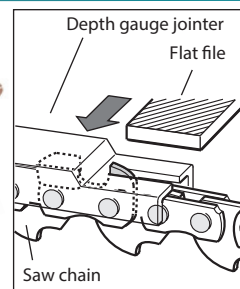

Guide Bar, Saw Chain and Bar cover

Guide Bar



Saw Chain



Guide Bar Cover



Cutter Type: CC: Chanfer chisel, FC: Full chisel, SC: Semi chisel

Guide Bar				Saw Chain						File Diameter	File diameter	
For Model	Bar length	Bar type	Guide Bar Part No.	Cutter type	Gauge	Pitch	Drive Links	Saw Chain Part No.	Bar Cover Part No.	1st half of top plate	2nd half of top plate	
EY265025H EY401MP	25cm/10"	Sprocket	165695-7	91VXL SC	1.3mm / 0.050"	3/8"	39	196142-7	452093-7			
UC120DWA	16cm/6-1/4"	-	158045-3	25AP SC	1.3mm / 0.050"	1/4"	42	791284-8	-	4.0mm	4.0mm	
EA3502S40B/ DUC405	40cm/16" (standard)	Sprocket	165202-6	90SG SC	1.3mm / 0.050"	3/8"	56	511492756	419560-5			
	40cm/16" (optional)	Sprocket	165247-4	90PX CC	1.1mm / 0.043"	3/8"	56	196742-3	419560-5			
EA4301F45B	45cm/18"	Sprocket	165390-9	91PX SC	1.3mm	3/8"	62	713080-4	419560-5			
DCS34 DCS4610	30cm/12"	Sprocket	442030661	91VG SC	1.3mm	3/8"	46	528092646	952100633	4.0mm	4.0mm	
	35cm/14"		442035661				52	531492652				
	40cm/16"		442040661				56	531492656				
DCS430	38cm/15"	Sprocket	-	95VP SC	1.3mm / 0.050"	0.325"	64	532484064	-	4.8mm	4.5mm	
	45cm/18"		-				72	532484072				952020640
	40cm/16"	Sprocket	-	-	SC	1.5mm / 0.058"	0.325"	-	-	-	-	
DCS430 DCS461 DCS460	38cm/15"	Sprocket	443038651	91VG SC	1.3mm / 0.050"	3/8"	56	-	952010630	5.5mm	4.8mm	
	45cm/18"		445045651				64	523093664	952020640			
DCS461 DCS460 DCS5200	38cm/15"	Sprocket	445038631	21BP SC	1.5mm / 0.058"	0.325"	64	528086664	952010630	4.8mm	4.5mm	
	45cm/18"		445045631				72	528086672	952020640			
	38cm/15"	Sprocket	443038651	73LP FC	1.5mm / 0.058"	3/8"	56	528099656	952010630	5.5mm	4.8mm	
	45cm/18"		445045651	73LP FC			64	528099664	952020640			
	53cm/21"		443053651	73LP FC			72	528099672	952020650			
DUC254 /DUC252 (standard with DUC252)	25cm/10"	Sprocket	168408-5	91VG SC	1.3mm / 0.050"	3/8"	40	196205-9	-	4.0mm	4.0mm	
DUC254 /DUC252 (standard with DUC254)	25cm/10"	Sprocket	161846-0	90PX CC	1.1mm / 0.043"	3/8"	40	199075-5	-			
DCS6401 / DCS7301 / DCS7901	38cm/15"	Sprocket	445038655	73LP FC	1.5mm / 0.058"	3/8"	60	528099660	-	5.5mm	4.8mm	
	50cm/20"		445050655				72	528099672				952100653
	45cm/18"	Solid	445045455	73LP FC	1.5mm / 0.058"	3/8"	68	528099668	-	5.5mm	4.8mm	
	60cm/24"		445060455				84	528099684				952100653
	70cm/28"		445070455				94	528099694				952100171
DCS9010	74cm/30"	Solid	445074452	73LP FC	1.5mm / 0.058"	3/8"	96	528099696	952100171	5.5mm	4.8mm	
	84cm/33"		445084422	27			FC	0.404"	100			522103700
5012B	30cm/12"	Sprocket	164533-0	91VG SC	1.3mm / 0.050"	3/8"	45	196519-6	-	4.0mm	4.0mm	
5016B	40cm/16"	Solid	341650-5	91VG SC	1.3mm / 0.050"	3/8"	56	196521-9	-	4.0mm	4.0mm	
UC4041A	40cm/16"	Sprocket	165247-4	90SG SC	1.1mm / 0.043"	3/8"	56	531291656	419242-9	4.5mm	4.0mm	
UC4041A	40cm/16"	Sprocket	165202-6	91VG SC	1.3mm / 0.050"	3/8"	56	531492656	419242-9	4.0mm	4.0mm	
UC4551A	45cm/18"	Sprocket	165390-9	91VG SC	1.3mm / 0.050"	3/8"	62	713080-4	419242-9	4.0mm	4.0mm	

BATTERY /
CHARGERS

FIXING FASTENING
(SCREWDRIVER BITS
/ IMPACT SOCKETS)

DRILLING
(WOOD / METAL/
MASONRY)

DRILLING
/ DEMOLITION
(CONCRETE)

CUTTING
(METAL)

MULTI TOOL
ACCESSORIES

DIAMOND
(CUTTING / GRINDING)

GRINDING
ACCESSORIES

SANDING
/ POLISHING
ACCESSORIES

SAWING
ACCESSORIES

ROUTERS
/ PLANERS
ACCESSORIES

CLEANERS
ACCESSORIES

HEAT GUN / LASERS
ACCESSORIES

BRAD NAILS/ PINS
STAPLER

GARDEN TOOLS
ACCESSORIES

HAND TOOLS /
COMBINATION SETS

Guide Bar, Saw Chain and Bar cover

Rescue Chain

	Type		Size	Part No
	Rescue cut chain	Chain Blade	45cm	957696064
	Rescue cut chain kit	Chain Blade and Guide bar set	45cm	957415040

Chainsaw Chain Reels

	Cutter type	Gauge	Pitch	Drive links	Part No
	90SG Micro-site	1.1mm / 0.403"	3/8"	1637	511291801
	91PX	1.3mm / 0.050"	3/8"	1637	957492802
	73LP	1.5mm / 0.058"	3/8"	1637	957099802
Packing Box for Chain Reels					959503105

File and Handle

Round File



dia. (mm)	Part no.	dia. (mm)	Part no.	dia. (mm)	Part no.
4.0	953003090	4.5	953003100	4.8	953003070

Chain File



Part no.
744003-1

Flat file



for depth limiter	Part no.
953003060	953100090

Chain filing guage



File handle



wooden

Part no.
953004010

File handle



Plastic

Part no.
953008020

File Holder



dia	Part no.
3/16"	953030030

Screwdrivers

Screwdriver

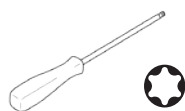

Size	Part no.
T27	944500860

Angle Screwdriver

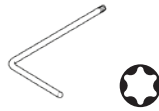

Size	Part no.
T27	940827000

Screwdriver

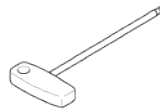

Size	Part no.
T27 200mm	944500862

Chain File

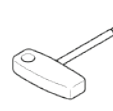

Size	Part no.
T27 100mm	944500861

Flat file Carburetor

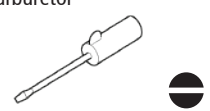

Part no.
944340001

Wrenches

Universal Socket Wrenches

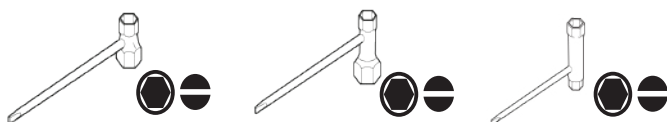

Size	Part no.	Size	Part no.	Size	Part no.
SW 13/19 mm	941719133	SW 17/19 mm	941717192	SW 13/16 mm	941716132

Test and Diagnostic Tools

Setting Guage For Ignition Armature



Size	Part no.
SW 17/19 mm	944500891

Pressure Tester

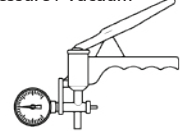

Size	Part no.
SW 13/16 mm	957004001

Blade type

A: Curving blade

Optimum blade shape for smooth cutting

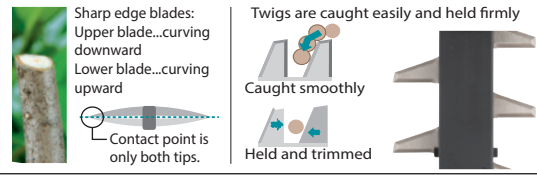

B: High grade blade

Upper/ Lower blade teeth with 3 sharpened edges for clean cut.

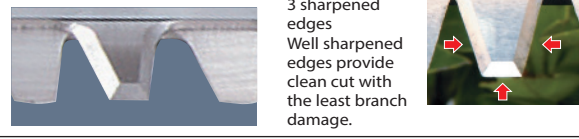

C: Stain-free blade



Non-electrolyzed nickel plating
Evenly and strongly adhered surface coating that features high anti-abrasion surface for long lasting coating.

Sap on the blade

(after 10 hour trimming of Boxwood)

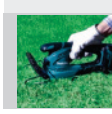

Hedge Trimmer Blade / Shear Blade

	For Model	Blade assembly Part No.	Upper blade Part No.	Lower blade Part No.	Blade Guard Part No.
 <p>Hedge Trimmer Blade</p>	EN401MP EN410MP EN4950H	197763-8			454279-9
	EN420MP	198195-2			457036-4
	DUN500	191C14-9			458413-3
	DUH551	196687-5			450489-6
	DUH754S	191D39-9			412356-3
	DUH751	199100-2			458408-6
	UH5260	9228MA0210			9101MA0203
	UH5261	140827-7			
	UH4570	194660-9			
	UH6570	194666-7			
	UH7580	194675-6			
	UH4850	222230620	222233220	222233320	
	UH6350	222230641	222233240	222233340	
	UH6540	222230631	223233230	223233330	
	HTR5600		6018505400	6018505500	
	HTR7610		6018505200	6018505301	
	EH760		6018505200	6018505301	
	EH6000W	196797-8			454672-7
	EH7500W	196799-4 / 126779-6			454672-7
	EH7500S	196801-3			346731-0
DUM604 / UM600D	198409-9			451816-0	
 <p>Shear Blade</p> 	DUM604 / UM600D	195176-7			451816-0

BATTERY / CHARGERS

FIXING FASTENING (SCREWDRIVER BITS / IMPACT SOCKETS)

DRILLING (WOOD / METAL / MASONRY)

DRILLING / DEMOLITION (CONCRETE)

CUTTING (METAL)

MULTI TOOL ACCESSORIES

DIAMOND (CUTTING / GRINDING)

GRINDING ACCESSORIES

SANDING / POLISHING ACCESSORIES

SAWING ACCESSORIES

ROUTERS / PLANERS ACCESSORIES

CLEANERS ACCESSORIES

HEAT GUN / LASERS ACCESSORIES



BRAD NAILS/ PINS STAPLER

GARDEN TOOLS ACCESSORIES

HAND TOOLS / COMBINATION SETS

Chip receiver

(For efficient collection and clean-up of clippings)

		For model	Part No.
		DUH754S	191D34-9
		EH7500S	195321-4
	Easy one-touch installation and removal	DUM604 / UM600D	198402-3



Edger Blade

(Cuts clean sharp grass edges along beds and paths)









Blade dia.	No. of teeth	Thickness	For model	Part No.
203mm	2T	2.5mm	EE2650H EE400MP	196745-7

Blade selection guide

	For short grass	For tall grass	For bush
	3-tooth, 4-tooth, 8-tooth For cutting thick grass, Suitable for cutting wide space		
	80-tooth For trimming bush, thick grass and etc.		
	TCT Adopted TCT tips. For thick grass		

Brush Cutter Blade

												
	3 Tooth	4 Tooth		8 Tooth		Saw Blade		T.C.T		Plastic blade set		
Blade dia(mm)	230mm	230mm	255mm	230mm	255mm	230 mm	255mm	230mm	250mm	255mm		230mm
No. of teeth	3T	4T	4T	8T	8T	80T	24T	36T	40T	M8x1.25RH M8x1.25LH M10x1.25LH		M8x1.25RH
Thickness	3.0	1.8	2.0	1.8	1.8	1.8	1.8	1.25	1.25	M8x1.25RH / LH M10x1.25LH		M8x1.25RH
Part No.	D-66020	B-14118	B-14124	B-14130	B-01909	B-14152	B-01921	D-65981	D-65997	198383-1	198384-9	198848-3
UR101C / 102C	•									•		
DUR369A	•									•		
DUR369N										•		
DUR364L										•	•	
DUR190	•							•		•		
DUR189										•	•	
UR100D												•
EM2500U	•	•		•		•		•				
RST250												
RBC2500		•		•		•						
EM2650UH	•	•		•		•						
RBC411U		•	•	•	•	•	•		•			
EM4350RH			•						•			
EM400MP	•	•		•		•						

198426-9 (12Pcs / Pkg) 198427-7 (12Pcs / Pkg) 198850-6 (5Pcs / Pkg)

Replacement plastic blades



Trimmer head Assembly

	Manual	Bump & Feed		Automatic						Automatic		
Type		B&F 4R	B&F 4L	B&F Z5L	95-M10L	95-M10L	B&F ECO 4R		95-M8R	UltraAuto 4R	UltraAuto 4L	SuperAuto XL
Size	5"	4"	4"	5"	4" <small>2.0mm x 2m</small>	4" <small>2.4mm x 3m</small>	4" <small>2.0mm x 3m</small>	3" <small>1.65mm x 3m</small>	4" <small>2.0mm x 3m</small>	4"	4"	
Arbore size	M12	M8x1.25RH	M8x1.25LH	M8x1.25LH	M10x1.25LH	M10x1.25LH	M8x1.25RH	M8x1.25RH	M8x1.25RH	M8x1.25RH	M8&10x1.25LH	M8x1.25LH
Part No.	B-02951	A-89137	A-89121	A-89143	198893-8	197804-0	197297-1	198853-0	198972-2	B-03006	B-02945 <small>(with adapter)</small>	B-01959
UR101C					•	•						
UR102C					•	•						
DUR369A					•	•						
DUR369N					•	•						
DUR364L							•					
DUR190					•	•						
DUR189							•		•			
DUR184L							•					
UR100D								•				
BBC300L	•				•	•					•	
EM2500U	•		•	•							•	
RST250	•	•								•		
RBC2500	•		•	•							•	•
EM2650UH	•				•	•					•	
RBC411U	•										•	
EM4350RH	•										•	
EM400MP	•				•	•					•	
ER400MP		•					•			•		

- BATTERY / CHARGERS
- FIXING FASTENING (SCREWDRIVER BITS / IMPACT SOCKETS)
- DRILLING (WOOD / METAL/ MASONRY)
- DRILLING / DEMOLITION (CONCRETE)
- CUTTING [METAL]
- MULTI TOOL ACCESSORIES
- DIAMOND [CUTTING / GRINDING]
- GRINDING ACCESSORIES
- SANDING / POLISHING ACCESSORIES

Eyelet 2pcs/set for Bump & Feed 4L/4R/Z5L, Ultra Auto 4R/4L/6L Part No. A-15992

UR3000



Spool Assembly

DA00000001

Trimmer head Assembly

Easy to replace nylon thread without dismantling the trimmer head

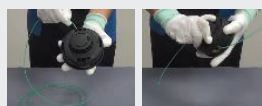

Insert

Turn



Four-leaf Nylon String Tap & Go System

Suitable for:
DUR369A / DUR369N /
UR101C / UR102C /
DUR190

4"
M10x1.25LH
2mm Dia
x 4m Length
191D89-4



5"
M10x1.25LH
2.4mm Dia
x 4m Length
191D93-3



- SAWING ACCESSORIES
- ROUTERS / PLANERS ACCESSORIES
- CLEANERS ACCESSORIES

Nylon Cord (String)

Type	Size (mm)	Part no.
Square Shaped Nylon String For String Trimmers (For heavy duty application - cutting thick grass)	Nylon Line Diameter - 3.0mm Nylon Line Length - 219 Metre	369224616
Nylon Cord For Brush Cutters	1.65mm x 15m	DA00000003
	2.4mm x 5m	B-01971
	3.0mm x 4m	B-07375
	2.4mm x 1,425m	B-04612



- HEAT GUN / LASERS ACCESSORIES
- BRAD NAILS/ PINS STAPLER
- GARDEN TOOLS ACCESSORIES
- HAND TOOLS / COMBINATION SETS

Nylon Cord (String) - Four Leaf Clover Like Cross Section

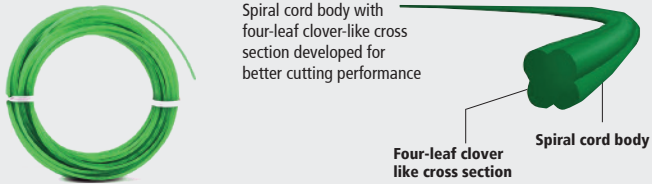
Type	Size (mm)	Part no.
<ul style="list-style-type: none"> • 2mm - well suited for use with high powered battery operated line trimmers • The new nylon cord features more sharpness, about 10% less noise, and about 15% less power consumption compared with the current one • Less jamming in bump & feed head due to rounded profile  <p>Spiral cord body with four-leaf clover-like cross section developed for better cutting performance</p> <p>Four-leaf clover like cross section</p> <p>Spiral cord body</p>	Size: 2.0mm-15meter	197472-9

Lawn Mowers Blade

For Model	Size (mm)	Part no.
DLM382	380	191D41-2
DLM460	460	199367-2
DLM431	430	197761-2
DLM530, DLM531, DLM532, DLM533	530	191D52-7
ELM3310	330	671142202
ELM3320	330	YA00000745
ELM3311	330	671002550
ELM3710	370	671014142
ELM3711	370	671002549
ELM3720	370	YA00000746
ELM4110	410	671001427
PLM4110	410	671001433
PLM4120	410	671001433
ELM4610, ELM4611, ELM4612, ELM4613	460	671146102
PLM4620N, PLM4621N, PLM4622N	460	671014610
PLM4620N2, PLM4621N2, PLM4622N2	460	D671001451
PLM5113N2	510	DA00000973
PLM5112	510	664004381

Rotary lawnmower 4 swing back blade

- 4 swing back blades have been designed to withstand harsh conditions.
- 4 swing back blades provides a clean and efficient cut with reduced chance of solid objects being struck and causing damage.



For Model	Size (mm)	Part no.
DLM531, DLM532, DLM533	530	191D50-1









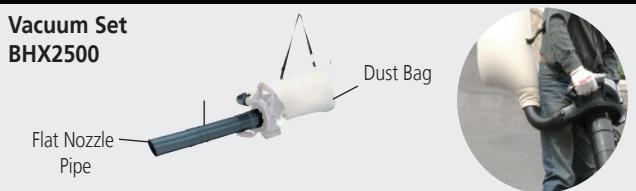

Replacement blade (4 pc.): **191D48-8**

Blower accessories

Flex Nozzle (allows concentrated airflow)

	For Model	Type	Size (mm)	Part No.
	DUB182, UB1100, UB1101, DVC350	Standard Equipment	220	132025-7
	DUB182, UB1100, UB1101, DVC350	-	430	134182-7
	UB1102, UB1103, UB100D, DUB185	Standard Equipment	220	123245-4
	UB1102, UB1103, UB100D, DUB185	-	430	123246-2

Nozzles

	Type	Part No.	
Vacuum Set BHX2500 	Nozzles are fixed	DEABHX2500S	
	Nozzles can be detached	JPABHX2500S	
	Nozzles can be detached	197234-5	
Vacuum Set DUB363 	Nozzles can be detached	191E19-1	
	End Pipe	BHX2500	451753-8
	Flat Nozzle	BHX2500	6659500901
	Extension Nozzle	DUB363, DUB362, UB400MP*, DUB184*	 197888-8
	Flat Nozzle	DUB363, DUB362, UB400MP*, DUB184*	 197889-6
	Adapter Pipe	DUB184	 191B21-6
	Adapter Pipe	UB400MP	 191C15-7

(*Note: Extension Nozzle and Flat nozzle only can fix with DUB184 and UB400MP with the help of adapter pipe)

Flexible Hose Set (for vacuum option)

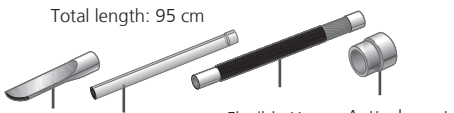
	For Model	Part No.
 <p>Total length: 95 cm</p>	UB1100, UB1101, DUB182	191750-9
	UB1102, UB1103, UB100D, DUB185	196643-5
Corner Nozzle:		411891-8
Staright Pipe:		191750-9
Flexible Hose:		191496-7
Aattachment		

Dust Bag (cloth bag for efficient collection)

	For Model	Part No.
	UB1100, UB1101	122321-1
	UB1102/103, UB100D, DUB185	123241-2
	DUB182	122814-8
	UB0801V	GT31105808

BATTERY /
CHARGERS

FIXING FASTENING
(SCREWDRIVER BITS
/ IMPACT SOCKETS)

DRILLING
(WOOD / METAL/
MASONRY)

DRILLING
/ DEMOLITION
(CONCRETE)

CUTTING
(METAL)

MULTI TOOL
ACCESSORIES

DIAMOND
(CUTTING / GRINDING)

GRINDING
ACCESSORIES

SANDING
/ POLISHING
ACCESSORIES

SAWING
ACCESSORIES

ROUTERS
/ PLANERS
ACCESSORIES

CLEANERS
ACCESSORIES

HEAT GUN / LASERS
ACCESSORIES







BRAD NAILS/ PINS
STAPLER

GARDEN TOOLS
ACCESSORIES

HAND TOOLS /
COMBINATION SETS

Sprayer accessories

Nozzles

	For Model	Recommended use	Part no.
 Long two head nozzle	EF1550RH, EVH2000	Wide spraying with wide angle outlet	6949001000 
 Y-shaped double nozzle	DVF104	Ideal for herbicides and soil conditioning and watering applications	6958029000 
 Wide angle nozzle	DVF104	Useful for pesticide, insecticide and fungicid applications	6958028000 

Oil

	Type	Content	Part No.
Chain oil chain oiling is formulated to adhere to the bar and chain and to reduce wear. Adhesion additive helps keep sap and pitch from clinging to the bar and chain.	Chain Oil	100ml	182229-1
	2 Stroke Oil	100ml	980008606
2 Stroke Oil Makita High-performance two-stroke engine oil is semi-synthetic oil with excellent lubricating qualities, low smoke and low carbon residue.		1 Litre	980008607
	BIOTOP Chain Oil (Biodegradable)	1 Litre	980008610
		5 Litre	980008611
	Combination Fuel Can	5 L Petrol 2.5 L oil	949000035
	4 Stroke Engine Oil	80 ml	197007-6
	4 Stroke Engine Oil	220 ml	195532-1

 100ML 1Litre
2 Stroke Oil

 4 Stroke Oil

 BIOTOP Chain Oil (1L / 5L)

 Combination Fuel Can
5L Petrol / 2.5 Litre Oil

Maintenance kit

	For Model	Part No.
Maintenance kits comes with spark plug, air filter and fuel filter which are needed for scheduled maintenance to keep the tool in top working condition 	EM2650UH/LH, EN4950H, EX2650, EY2650	197680-2
	RBC411	197690-9
	RBC2500, RST250	197688-6
	PM7650 / 51	198936-6
	EK7651	199003-0
	EB7660TH, EB7660THG, EB7660WH	198437-4

BATTERY / CHARGERS

FIXING FASTENING (SCREWDRIVER BITS / IMPACT SOCKETS)

DRILLING (WOOD / METAL / MASONRY)

DRILLING / DEMOLITION (CONCRETE)

CUTTING [METAL]

MULTI TOOL ACCESSORIES

DIAMOND (CUTTING / GRINDING)

GRINDING ACCESSORIES

SANDING / POLISHING ACCESSORIES

SAWING ACCESSORIES

ROUTERS / PLANERS ACCESSORIES

CLEANERS ACCESSORIES

HEAT GUN / LASERS ACCESSORIES

BRAD NAILS/ PINS STAPLER

GARDEN TOOLS ACCESSORIES

HAND TOOLS / COMBINATION SETS

Hand Tools / Combination Sets



Tape Measure

Makita measurement tape which is highly durable and convenient to use. Normally when the scales are blurred or hook is lost, that would be the end of tape's life. This measuring tape is designed for professionals which has specially coated tape and hook protector's damper for absorbing shocks. This helps increasing durability of the measuring tape.



1. Special Coating

"DURA COAT" for 5 times more durable
"SILICA COAT" for easy note



2. High durability of Hook

Installed damper to absorb the shock on a hook
Hook protector to reduce the shock on a hook
Tightly fixed hook with "4rivets+protector"

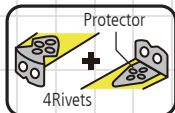

3. Convenience

2-sided printing
Hook with magnet
"Matte finish" to easy to read scales
Standout



Printed size

mm



Inch



mm/Inch



Tape measure with holder & safety cord

The holder can be attached to waist belt and the measure can be attached/detached from a holder by single touch.



The measure and holder is tied by a safety cord so even you drop a measuring at high work place, safety cord avoids measure being fallen.



Attachable measure with a single touch. Press down the yellow lever and lift the measure.



Tape Measure



Size	Length	Width	Part No.
mm	3.5m	16mm	B-57130



Size	Length	Width	Part No.
mm/inch	5.5m/18ft	25mm/1"	B-57211
mm/inch	7.5m/25ft	25mm/1"	B-57227



Size	Length	Width	Part No.
mm	10m	25mm	B-57168



Tape measure with holder & safety cord



Size	Length	Width	Part No.
mm	7.5m	25mm	B-57174

Snap-off Knife

This snap-off knife is suitable for DIY user, repair shop, interior decoration, etc. It contains 7 spare blades inside the body plus the preinstalled blade on the body (total 8pcs blades).



	Part No
Snap-off knife	D-65713

Retractable Utility Knife

- Quick blade change for easy and fast replacement
- Accepts all standard type utility knife blades
- Safety string cutter with recessed blade



	Part No
Retractable Utility Knife	B-65785

Quick Change Folding Utility Knife

- Quick blade change for easy and fast replacement
- Accepts all standard type utility knife blades



Folding Blade Safety, Compact

	Part No
Quick Change Folding Utility Knife	B-65501

Standard Knife Blades

For Retractable Utility Knife & Quick Change Folding Utility Knife

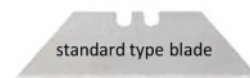

	Part No
Knife Blades 10pcs. Set	B-65517

BATTERY / CHARGERS

FIXING FASTENING (SCREWDRIVER BITS / IMPACT SOCKETS)

DRILLING (WOOD / METAL / MASONRY)

DRILLING / DEMOLITION (CONCRETE)

CUTTING (METAL)

MULTI TOOL ACCESSORIES

DIAMOND (CUTTING / GRINDING)

GRINDING ACCESSORIES

SANDING / POLISHING ACCESSORIES

SAWING ACCESSORIES

ROUTERS / PLANERS ACCESSORIES

CLEANERS ACCESSORIES

HEAT GUN / LASERS ACCESSORIES

BRAD NAILS/ PINS STAPLER

GARDEN TOOLS ACCESSORIES

HAND TOOLS / COMBINATION SETS

BATTERY / CHARGERS

Smooth face claw hammer

Anti-Ring claw

Allows you to extract the nails which have been hammered by mistake

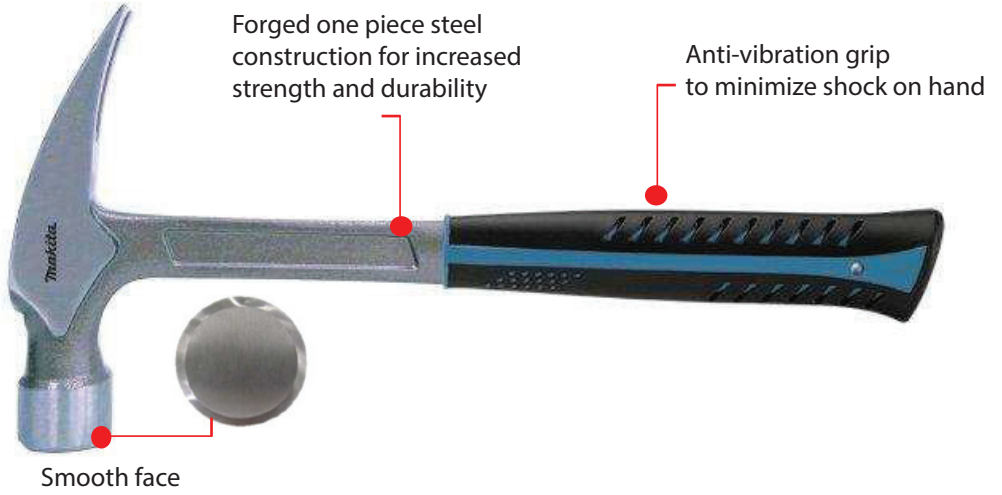

TYPE		PART NO
Smooth Face Claw	20 Oz	B-65779

FIXING FASTENING (SCREWDRIVER BITS / IMPACT SOCKETS)

DRILLING (WOOD / METAL / MASONRY)

DRILLING / DEMOLITION (CONCRETE)

CUTTING [METAL]

MULTI TOOL ACCESSORIES

DIAMOND [CUTTING / GRINDING]

GRINDING ACCESSORIES

SANDING / POLISHING ACCESSORIES

SAWING ACCESSORIES

ROUTERS / PLANERS ACCESSORIES

CLEANERS ACCESSORIES

HEAT GUN / LASERS ACCESSORIES

BRAD NAILS/ PINS STAPLER

GARDEN TOOLS ACCESSORIES

Flare nut wrenches 5pcs set

- Offset Box ends spread turning force throughout the entire fastener head for a solid hold
- Large contact surface with fastener reduces rounding Suitable for aluminum, copper and brass hexagonal fittings on oil pipe



		PART NO.
9x11, 10x12, 13x14, 15x17, 16x18mm	5pcs set	B-65545

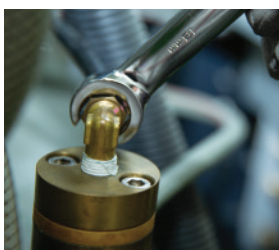

Double box wrenches 5pcs set



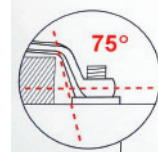





- 75° Offset ends allow you to work in tight spaces and offer comfortable hand clearance
- 12 points of contact for dependable grip and strength



SIZES		PART NO.
8x9, 10x11, 12x13, 14x15, 18x19mm	5pcs set	B-65551

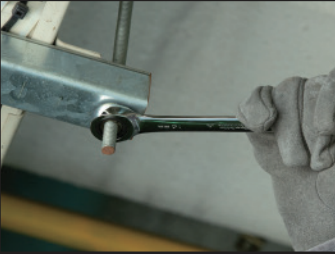

Wrenches

Adjustable wrench				Wide excursion jaw allows each tool to work with even more fastener sizes.
Spanner	Open end			U-shaped opening grips with two opposite face of the bolts and nuts. Due to the opening, it can easily access to bolts and nut.
	Flare end			Narrow opening which is wide enough to fit over the tube. Large contact surface with fastener reduces rounding. Suitable for aluminum, copper and brass hexagonal fittings on oil pipe.
	Box end			Enclosed opening grips snugly fits the faces of the bolts and nuts. Force can be applied to bolts or nuts with decreased chance of damaging.
Ratcheting wrench				The ratcheting mechanism allows fastener to be tightened or loosened without disconnecting the tool from it. It makes the works more rapidly.
Hex key wrench with ball-end				Used for tightening or loosening cap screw and bolts with hexagonal sockets attached to their heads. A ball end allows the tool to be used at an angle off-axis to screw and bolt. It means it can used at tightening area.



11Pc Pass thru adjustable wrench set

Sockets works on 6-point, 12-point, square, E-T, spline and partially rounded hex fasteners



Truly universal sockets fit both SAE and metric fasteners

Laser etched scaled (SAE/MM) for quick and easy adjustments to fastener size

Hex jaw design reduces slippage and grips bolt tightly

Angled tooth pattern on the pipe wrench jaw side provides extra gripping force

Pass-thru socket/wrench gripping force system works over long threaded rod



Can be used as a pipe wrench

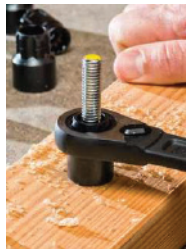

Makita



Standard type

PACKAGE



10pcs 3/8" socket: 3/8" (10mm), 7/16" (11mm), 15/32" (12mm), 1/2" (13mm), 9/16" (14mm), 19/32" (15mm), 5/8" (16mm), 11/16" (17mm), 23/32" (18mm), 3/4" (19mm) 1pc adjustable wrench: 200mm

B-65458

BATTERY / CHARGERS

FIXING FASTENING (SCREWDRIVER BITS / IMPACT SOCKETS)

DRILLING (WOOD / METAL / MASONRY)

DRILLING / DEMOLITION (CONCRETE)

CUTTING [METAL]

MULTI TOOL ACCESSORIES

DIAMOND [CUTTING / GRINDING]

GRINDING ACCESSORIES

SANDING / POLISHING ACCESSORIES

SAWING ACCESSORIES

ROUTERS / PLANERS ACCESSORIES

CLEANERS ACCESSORIES

HEAT GUN / LASERS ACCESSORIES

BRAD NAILS / PINS STAPLER

GARDEN TOOLS ACCESSORIES

HAND TOOLS / COMBINATION SETS

Double ratchet wrenches 8pcs set

- Speed of ratcheting + easy access of an open-end wrench



Ratcheting Function at Box End

SIZES		PART NO.
8, 10, 12, 13, 14, 15, 17, 19mm	8pcs set	B-65523



Combination wrenches 9pcs set

- Box End 15° offset providing knuckle clearance
- Ratcheting Function at Box End



SIZES		PART NO.
8, 10, 12, 13, 14, 15, 16, 17, 18mm	9pcs set	B-65539

Adjustable wrench

- Wide Capacity Jaw.
- Hex jaw design reduces slippage and grips bolt tightly.



SIZE (LENGTH)	JAW	PART NO
6" / 150mm	0-29mm	B-65414
8" / 200mm	0-36mm	B-65420
10" / 250mm	0-38mm	B-65436
12" / 300mm	0-43mm	B-65442

BATTERY / CHARGERS

FIXING FASTENING (SCREWDRIVER BITS / IMPACT SOCKETS)

DRILLING (WOOD / METAL / MASONRY)

DRILLING / DEMOLITION (CONCRETE)

CUTTING (METAL)

MULTI TOOL ACCESSORIES

DIAMOND (CUTTING / GRINDING)

GRINDING ACCESSORIES

SANDING / POLISHING ACCESSORIES

SAWING ACCESSORIES

ROUTERS / PLANERS ACCESSORIES

CLEANERS ACCESSORIES

HEAT GUN / LASERS ACCESSORIES

BRAD NAILS/ PINS STAPLER

GARDEN TOOLS ACCESSORIES

HAND TOOLS / COMBINATION SETS

BATTERY / CHARGERS

Locking Adjustable Wrench

- Jaw features grooved teeth for added grip
- Delivers 2X gripping power on rounded fasteners



SIZES	MAX JAW SIZE	PART NO.
10" / (250mm)	Ø35mm	B-65470



FIXING FASTENING (SCREWDRIVER BITS / IMPACT SOCKETS)

DRILLING (WOOD / METAL / MASONRY)

DRILLING / DEMOLITION (CONCRETE)

CUTTING (METAL)

MULTI TOOL ACCESSORIES

DIAMOND (CUTTING / GRINDING)

GRINDING ACCESSORIES

SANDING / POLISHING ACCESSORIES

SAWING ACCESSORIES

ROUTERS / PLANERS ACCESSORIES

CLEANERS ACCESSORIES

Hex key wrenches 9pcs set

- Ball point for confined place and fastening in max 25°angle



SIZES		PART NO.
1.5, 2, 2.5, 3, 4, 5, 6, 8, 10mm	9pcs set	B-65894

HEAT GUN / LASERS ACCESSORIES

BRAD NAILS/ PINS STAPLER

GARDEN TOOLS ACCESSORIES

HAND TOOLS / COMBINATION SETS

Box-joint water pump pliers

- 24 positions of fine adjustment for optimum adaptation

Push button type adjustment



OVERALL LENGTH	MAX JAW SIZE	PART NO.
7" (180mm)	Ø37mm	B-65741
9.5" (240mm)	Ø49mm	B-65757
12" (300mm)	Ø68mm	B-65763

Water pump pliers

- "V" Jaws with Special Design and Induction Hardened Teeth Allow for Firmer Grip



OVERALL LENGTH	MAX JAW SIZE	PART NO.
10" / (250mm)	Ø51mm	B-65486
12" / (300mm)	Ø76mm	B-65492



Aviation snips

Available in 4 types.

- Cuts Right
- Cuts Left
- Cuts Straight
- Bulldog

Chrome-Molybdenum alloy steel forged blades for strength & durability

Center fastener for high tensile strength provided for longer life

Spring-free auto latch design for one hand operation provides safety and convenience

Aviation snip - Cuts Right



CAPACITY		PART NO
Cold-rolled steel	18ga (1.22mm)	B-65816
Stainless steel	23ga (0.61mm)	

Aviation snip - Cuts Left



CAPACITY		PART NO
Cold-rolled steel	18ga (1.22mm)	B-65800
Stainless steel	23ga (0.61mm)	

Aviation snip - Cuts Straight



CAPACITY		PART NO
Cold-rolled steel	18ga (1.22mm)	B-65791
Stainless steel	23ga (0.61mm)	

Aviation snip - Bulldog



CAPACITY		PART NO
Cold-rolled steel	16ga (1.63mm)	B-65822
Stainless steel	18ga (1.22mm)	

34Pcs. 1/4" Ratchet & socket set



TYPE	PART NO
1/4" SQ 84T Ratchet, 1/4" bit adapter,	B-65567
1/4" SQ slide T bar	
1/4" SQ socket : 4, 4.5, 5, 5.5, 6, 7, 8, 9, 10, 11, 12, 13mm	
1/4" SQ deep socket : 5, 6, 7, 8, 9, 10, 11, 12, 13mm	
1/4" SQ Extension bar : 3", 6"	
T bit : T8, T10, T15, T20, T25, T27, T30, T40x25mm	

23Pcs. 1/2" Ratchet & socket set



TYPE	PART NO
1/2" SQ 84T Ratchet,	B-65589
1/2" SQ adapter to 3/8" SQ,	
1/2" SQ universal joint	
1/2" SQ socket : 10, 11, 12, 13, 14, 15, 16, 17, 18, 19, 20, 21, 22, 23, 24, 27, 30, 32mm	
1/2" SQ Extension bar : 5", 10"	

21Pcs. Pass thru socket set



TYPE	SIZE	PART NO
Pass thru Socket	10mm, 11mm, 12mm, 13mm, 14mm, 15mm, 16mm, 17mm, 18mm, 19mm,	B-65604
Pass thru Socket	3/8", 7/16", 1/2", 9/16", 5/8", 11/16", 3/4"	
Socket adapter	1/4", 3/8"	
Pass thru Extension bar	75mm	
Ratchet handle	(Pass thru handle Straight)	

BATTERY / CHARGERS

FIXING FASTENING (SCREWDRIVER BITS / IMPACT SOCKETS)

DRILLING (WOOD / METAL / MASONRY)

DRILLING / DEMOLITION (CONCRETE)

CUTTING (METAL)

MULTI TOOL ACCESSORIES

DIAMOND (CUTTING / GRINDING)

GRINDING ACCESSORIES

SANDING / POLISHING ACCESSORIES

SAWING ACCESSORIES

ROUTERS / PLANERS ACCESSORIES

CLEANERS ACCESSORIES

HEAT GUN / LASERS ACCESSORIES

BRAD NAILS / PINS STAPLER

GARDEN TOOLS ACCESSORIES

HAND TOOLS / COMBINATION SETS

BATTERY / CHARGERS

14Pcs. Pass thru socket set



TYPE	SIZE	PART NO
Pass thru Socket	10mm, 11mm, 12mm, 13mm,	B-65595
	14mm, 15mm, 16mm, 17mm,	
	18mm, 19mm,	
Socket adapter	1/4", 3/8"	
Pass thru Extension bar	75mm	
Ratchet handle	(Pass thru handle Straight)	

FIXING FASTENING (SCREWDRIVER BITS / IMPACT SOCKETS)

DRILLING (WOOD / METAL / MASONRY)

DRILLING / DEMOLITION [CONCRETE]

CUTTING [METAL]

MULTI TOOL ACCESSORIES

Locking Flex Pass thru Handle



TYPE	PART NO
Locking Flex Pass thru Handle	B-65626

DIAMOND [CUTTING / GRINDING]

GRINDING ACCESSORIES

SANDING / POLISHING ACCESSORIES

SAWING ACCESSORIES

ROUTERS / PLANERS ACCESSORIES

Pass thru handle Straight



TYPE	PART NO
Pass thru handle Straight	B-65610

CLEANERS ACCESSORIES

Pass thru Socket



SIZE	PART NO
10mm	B-65648
11mm	B-65654
12mm	B-65660
13mm	B-65676
14mm	B-65682
15mm	B-65698
16mm	B-65707
17mm	B-65713
18mm	B-65729
19mm	B-65735

HEAT GUN / LASERS ACCESSORIES

BRAD NAILS/ PINS STAPLER

GARDEN TOOLS ACCESSORIES

HAND TOOLS / COMBINATION SETS

Pass thru extension bar



TYPE	PART NO
Pass thru Extension bar	B-65632

Socket adapter



TYPE	PART NO
Socket adapter	B-65844

Ratcheting tap & die handle



TYPE	PART NO
Ratcheting tap & die handle	B-65866

Tap Adapter



TYPE	PART NO
Tap Adapter	B-65872

Twist lock die adapter



TYPE	PART NO
Twist lock die adapter	B-65888

40Pcs Ratchet tap & die set



TYPE	SIZE	PART NO.
Small/Medium Ratcheting T Wrench		B-65838
Small Tap Adapter		
Medium Tap Adapter		
Medium Hex Die Adapter		
Screwdriver		
Pitch Gauge		
NC Hex Die	3mmx0.50, 3mmx0.60, 4mm x 0.70, 4mm x 0.75, 5mm x 0.80, 5mm x 0.90, 6mm x 1.00, 7mm x 1.00, 8mm x 1.25, 9mm x 1.25, 10mm x 1.50, 11mm x 1.50, 12mm x 1.75	
NC Plug Tap	8mm x 1.25, 9mm x 1.25, 10mm x 1.50, 11mm x 1.50, 12mm x 1.75	
NC Taper Tap	3mm x 0.50, 3mm x 0.60, 4mm x 0.70, 4mm x 0.75, 5mm x 0.80, 5mm x 0.90, 6mm x 1.00, 7mm x 1.00	
NF Hex Die	9mm x 1.00, 10mm x 1.25, 12mm x 1.50	
NF Plug Tap	9mm x 1.00, 10mm x 1.25, 12mm x 1.50	
BSP Hex Die	1/8-28	
BSP Tap	1/8-28	

BATTERY /
CHARGERSFIXING FASTENING
(SCREWDRIVER BITS
/ IMPACT SOCKETS)DRILLING
(WOOD / METAL/
MASONRY)DRILLING
/ DEMOLITION
(CONCRETE)CUTTING
(METAL)MULTI TOOL
ACCESSORIESDIAMOND
(CUTTING / GRINDING)GRINDING
ACCESSORIESSANDING
/ POLISHING
ACCESSORIESSAWING
ACCESSORIESROUTERS
/ PLANERS
ACCESSORIESCLEANERS
ACCESSORIESHEAT GUN / LASERS
ACCESSORIESBRAD NAILS/ PINS
STAPLERGARDEN TOOLS
ACCESSORIESHAND TOOLS /
COMBINATION SETS

21pcs. Screw Bit & Socket Set with Ratchet Handle



The Screw Bits are very easy to distinguish due to the colour paint on the bit head

Type / Size /Pcs	Part no
3Pcs - Phillips bits: PH1, PH2, PH3 x 25mm	B-54081
2pcs - Slotted bits: SL0.8x5.5 x 25mm SL1.2x6.5 x 25mm	
3pcs - Torx bits T20,T25,T30 x 25mm	
2pcs - Pozi bits PZ1, PZ2 x 25mm	
2pcs - Hex bits H4, H6 x 25mm	
25mm Adapter - 1/4" Sand finished for hand	
6pcs - Socket Wrench with 6point for hand H5,H6,H8,H10,H12,H13	
1pc Magnetic Bit Holder - 60mm	
Mini Ratchet Wrench - 100mm	

BATTERY / CHARGERS

Ratchet Screwdriver

With screw bit 25mm (PH2)x1pcs.
Ratchet handle function is applied (clockwise and anticlockwise is possible).
Suitable for car maintenance, interior decoration, repair room, DIY etc.



FIXING FASTENING (SCREWDRIVER BITS / IMPACT SOCKETS)

Ratchet screwdriver	Part No D-58833
---------------------	---------------------------

DRILLING (WOOD / METAL / MASONRY)

11 pcs Ratchet Screwdriver Pouch with Ratchet Handle



Pouch

Type / Size / Pcs	Part no
7 pcs - 50mm screwdriver bits sizes Size: 4pcs Phillips bits: 1pc of PH1 2pc of PH2 1pc of PH3	P-90180
3pcs Slotted bits: 1pc of 5/32 1pc of 3/16 1pc of 1/4	
1pc - 25mm PH2 screwdriver bit	
1 pc - Speed Handle	
1pc - Magnetic quick change hex chuck	
1pc - 80mm Magnetic extension bar	
Zip pouch	

DRILLING / DEMOLITION [CONCRETE]

CUTTING [METAL]

MULTI TOOL ACCESSORIES

DIAMOND [CUTTING / GRINDING]

GRINDING ACCESSORIES

SANDING / POLISHING ACCESSORIES

Screwdrivers - Standard Type

- Ergonomic handle for best hand comfort.
- Anti-Slip and Oil Resistant Dual Material.



Clear mark of size and type in handle makes your quick and easy identify



TYPE	SIZE	Part No
PH1	#1X100	B-65903
PH2	#2X100	B-65919
PH3	#3X150	B-65931
PZ1	#1X80	B-65947
PZ2	#2X100	B-65953
PZ3	#3X150	B-65969
T10	T10X100	B-65975
T15	T15X100	B-65981
T20	T20X100	B-65997
T25	T25X100	B-66008
T30	T30X100	B-66014
SL4.0	4X100	B-66020
SL5.5	5.5X100	B-66036
SL6.5	6.5X125	B-66042
SL8	8X150	B-66058

Screwdrivers - Go Through Type

- Distinctive two tone grip design handle
- Ergonomic handle for best hand comfort
- Anti-Slip and Oil Resistant Dual Material



"Go-Through" construction provides greater striking force than traditional cap ends



TYPE	SIZE	Part No
PH1	#1X75mm	B-66064
PH2	#2X100mm	B-66070
PH3	#3X150mm	B-66086
PZ1	#1X75mm	B-66092
PZ2	#2X100mm	B-66101
PZ3	#3X150mm	B-66117
S5.5	5.5x75mm	E-04933
SL6.5	6.5x150mm	E-04949
SL8	8.0x200mm	E-04955

ROUTERS / PLANERS ACCESSORIES

CLEANERS ACCESSORIES

HEAT GUN / LASERS ACCESSORIES

BRAD NAILS/ PINS STAPLER

GARDEN TOOLS ACCESSORIES

HAND TOOLS / COMBINATION SETS

Shock Driver

Makita shock driver is very useful tool which is able to be used as a regular hand driver and a shock driver when you work on the stripped screw.



This handy driver can remove the crushed or stripped screws which could not be loosened by electric tools. Applying the impact onto the handle generates a torque in the rotation direction, so the stripped screws can be removed.



How to remove



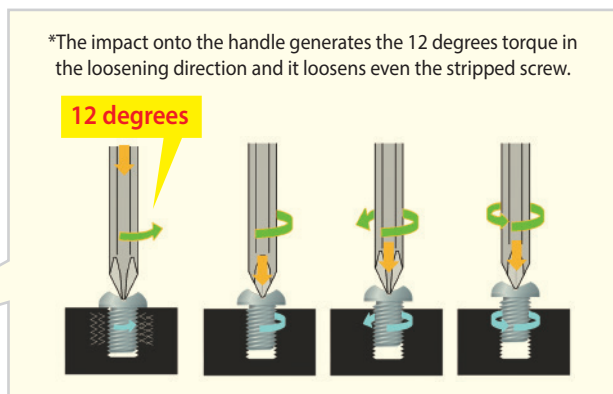
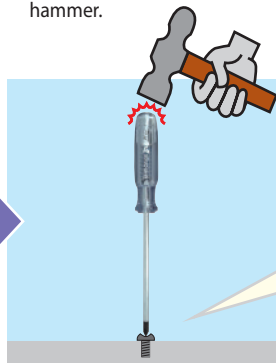
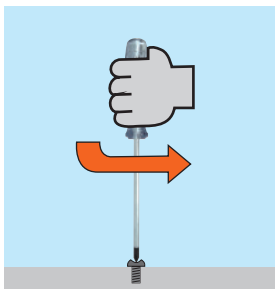

While applying force in the fastening direction, hold the grip securely.

2. Apply strong impact with the hammer.



*The impact onto the handle generates the 12 degrees torque in the loosening direction and it loosens even the stripped screw.

DIFFERENCE BETWEEN NORMAL DRIVER AND NEW SHOCK DRIVER

Item	Screw removal 	Stripped / Crushed screw removal 
MAKITA SHOCK DRIVER 	✓	✓
NORMAL SCREW DRIVER 	✓	✗

Please note: Our shock driver is intended for machine screws only. It is not suitable for screws into soft member such as wood screw or topping screw. Even after applying impact, the soft member might absorb the impact, or member itself might break. Also, it cannot be used for even machine screws that attach soft member such as aluminum, copper or thin board.



Size	Length	Part No
PH2	125mm	B-42438

BATTERY / CHARGERS

FIXING FASTENING (SCREWDRIVER BITS / IMPACT SOCKETS)

DRILLING (WOOD / METAL / MASONRY)

DRILLING / DEMOLITION (CONCRETE)

CUTTING (METAL)

MULTI TOOL ACCESSORIES

DIAMOND (CUTTING / GRINDING)

GRINDING ACCESSORIES

SANDING / POLISHING ACCESSORIES

SAWING ACCESSORIES

ROUTERS / PLANERS ACCESSORIES

CLEANERS ACCESSORIES

HEAT GUN / LASERS ACCESSORIES

BRAD NAILS/ PINS STAPLER

GARDEN TOOLS ACCESSORIES

HAND TOOLS / COMBINATION SETS

- BATTERY / CHARGERS
- FIXING FASTENING (SCREWDRIVER BITS / IMPACT SOCKETS)
- DRILLING (WOOD / METAL / MASONRY)
- DRILLING / DEMOLITION (CONCRETE)
- CUTTING [METAL]
- MULTI TOOL ACCESSORIES
- DIAMOND [CUTTING / GRINDING]
- GRINDING ACCESSORIES
- SANDING / POLISHING ACCESSORIES
- SAWING ACCESSORIES
- ROUTERS / PLANERS ACCESSORIES
- CLEANERS ACCESSORIES
- HEAT GUN / LASERS ACCESSORIES
- BRAD NAILS/ PINS STAPLER
- GARDEN TOOLS ACCESSORIES
- HAND TOOLS / COMBINATION SETS

LED Pen Light

Compact, light and easy to carry
 Application: Repair room,
 Car maintenance, DIY, etc
 Compatibile with AA battery



Type / Size	Part No
LED Pen Light (without battery)	D-58752

10 pcs Bit Set

Popular drive bits are packed together in a convenient set.



Type / Size	Part No
2 x Philips: PH2x2pcs 4 x Pozi: PZ1x1pc, PZ2x2pcs, PZ3x1pc 2 x Torx: T15x1pc, T25x1pc 1 x Flat: 0.6x4.5 1 x Flat: 1.2 x 6.5	P-16782
1 x Holder Plastic box	

49 pcs Maklok and 4-way driver set



Type / Size /Pcs	Part no
40 x 25 mm (L) Screwdriver Bits Size: 10x Phillips: PH0x2pcs, PH1x2pcs, PH2x4pcs, PH3x2pcs 10x Pozi: PZ0x2pcs, PZ1x2pcs, PZ2x4pcs, PZ3x2pcs 8x Slotted: 3x2pcs, 4x2pcs, 5x2pcs, 6x2pcs 4x Torx: T10, T15, T20, T25 8x Hex: 3x2pcs, 4x2pcs, 5x2pcs, 6x2pcs	P-52043
5x Nutdrivers Size: 6/7/8/10mm & 5/16"	
1x Maklok Quick Change Chuck	
1x No.8 4xWay Driver Body with 25mm Pozi 2 Bit	
1x 4xWay Driver Barrel	
1x Industrial Quad-Driver	
Plastic Case	

28 pcs Long life bit set



Type / Size	Part No
28 x 50mm (L) Bits with titanium coating Size: 10 x Pozi: PZ0x2pcs, PZ1x3pcs PZ2x3pcs, PZ3x2pcs 4 x Slotted: 3/4/5/6 mm 4 x Hex: 3/4/5/6 mm 7x Torx: T8/10/15/20/25/30/40 3x Phillips: PH1x1pc, PH2x1pc, PH3x1pc	P-51976
Plastic Case	

14 pcs Mini Chuck Set

For use with 3 Jaw or Maklok chuck.



Type / Size	Part No
13x 25 mm Bits, Size: 3x Phillips: PH1x1pc, PH2x1pc, PH3x1pc 4x Pozi: PZ1x1pc, PZ2x2pcs PZ3x1pc 4-Slotted: 3/4/5/6 mm 2-Hex: 4/6 mm	P-51960
1x Mini-Chuck	

Maklok Chuck

For use on 1/4" Drive Tools and 3 Jaw Chucks



Type / Size	Part No
1x Maklok Quick Change Chuck	P-51421

Stubby screw guide

Holds and guides screw in the correct position without wobbling or disengaging from the bit.



Type / Size	Part No
1x 80mm Stubby Screw Guide	P-46268
3x 25mm Bits, Size: 2x Pozidrive: PZ1, PZ2	
1x Slotted: 6-8	

12 pcs 4-Way Driver Set & Pouch



Type / Size	Part No
1x 4-Way Driver Barrel	P-46327
2x 4-Way Driver Body With No.8 Pilot and Pozi 2 Bits	
1x No.6 Pilot & Countersink Assembly	
1x No.10 Pilot & Countersink Assembly	
1x No.12 Pilot & Countersink Assembly	
6x Replacement Pilot Drill Bits	
Quick change driver and drill set with countersink	

17 pcs Maklok Drill and drive set



Type / Size	Part No
4x Nutdrivers, Size: 5/16", 6mm, 7mm, 8mm	P-51867
1x Maklok Quick Change Chuck	
7x 50mm(L) Bit, Size: 2x Phillips: Ph1, Ph2 5x Pozi: Pz1, Pz2x3pcs, Pz3	
5x Hex Shank Masonry Drill, Size: 5.5/6.5/7/8mm	
Plastic Case	

20 pcs Quick change Drill / Driver set



Type / Size	Part No
1x 1/4" Quick-Change Adaptor	P-46311
6x 1/4" Hexagon Shank HSS. Drill Bits (Titanium Coated), Size: 1.5, 2, 2.5, 3.2, 5, 6.5mm	
1x Stubby Finder/Driver With Pozi 2 Bit	
6x 25mm Screwdriver Bits, Size: 3x Phillips: Ph1, Ph2, Ph3 3x Pozi: PZ1/2/3	
5x 1/4" Drive Sockets, Size: 5/16", 6, 7, 8, 10mm	
1x Project Injection Case W/Clear Cover	

29 pcs Drill bit, guide & driver set



Type / Size	Part No
8x 25mm BIT, W/Plastic Holder, Size: 4x Pozi: Pz0, Pz1, Pz2, Pz3 4x Phillips: Ph0, Ph1, Ph2, Ph3 4x Slotted: 4,5,6,7mm 2x Torx: T10, T15 2x Square: S1, S2	P-46523
1x Quick Change Adaptor	
1x Stubby Finder Driver	
1x 4xWay Driver Barrel	
1x 4-Way Driver Body	
1x Centre Drilling Guide Body	
8x Hexagon Shank HSS Drill Bits (Titanium Coated), Size: 2.5, 3.2, 3.5, 4, 4.5, 5, 5.5, 6mm	
Pouch Bag	

BATTERY / CHARGERS

FIXING FASTENING (SCREWDRIVER BITS / IMPACT SOCKETS)

DRILLING (WOOD / METAL/ MASONRY)

DRILLING / DEMOLITION (CONCRETE)

CUTTING (METAL)

MULTI TOOL ACCESSORIES

DIAMOND (CUTTING / GRINDING)

GRINDING ACCESSORIES

SANDING / POLISHING ACCESSORIES

SAWING ACCESSORIES

ROUTERS / PLANERS ACCESSORIES

CLEANERS ACCESSORIES

HEAT GUN / LASERS ACCESSORIES

BRAD NAILS/ PINS STAPLER

GARDEN TOOLS ACCESSORIES

HAND TOOLS / COMBINATION SETS

BATTERY / CHARGERS

FIXING FASTENING (SCREWDRIVER BITS / IMPACT SOCKETS)

DRILLING (WOOD / METAL / MASONRY)

DRILLING / DEMOLITION [CONCRETE]

CUTTING [METAL]

MULTI TOOL ACCESSORIES

DIAMOND [CUTTING / GRINDING]

GRINDING ACCESSORIES

SANDING / POLISHING ACCESSORIES

SAWING ACCESSORIES

ROUTERS / PLANERS ACCESSORIES

CLEANERS ACCESSORIES

HEAT GUN / LASERS ACCESSORIES

BRAD NAILS/ PINS STAPLER

GARDEN TOOLS ACCESSORIES

HAND TOOLS / COMBINATION SETS

Fast Change Countersink Set

For use with 3 Jaw & Maklok chucks and 1/4" Hex drive tools



All in one: Pilot drill and countersink for wood working applications

Type	Size (mm)	Pc/ Pkg	Part No
Fast change countersink	6	1	P-51954
	8	1	
	10	1	
	12	1	
Hex Wrench	-	1	

18pcs metal drill box set

3 different types of bits in 5 different sizes:

- HSS-G metal drill bit - for metal
- Masonry drill bit - for brick
- Brad point wood drill bit - for wood

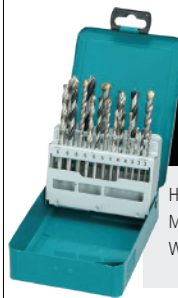

	Size (mm)	Pc/ Pkg	New Part No (With country of origin)
HSS-G, Masonry, Wood drill bit	3, 4, 5, 6, 8, 10	Each 1pc	D-46399

9pcs Drill bits set (Assorted)

3 different types of bits in 3 different sizes:

- HSS-tin drill bit - for metal (3pcs)
- Carbide tipped drill bit - for masonry (3pcs)
- Wood drill bit - for wood (3pcs)



	Size (mm)	Pc/ Pkg	New Part No (With country of origin)
HSS-tin drill bit, Carbide tipped drill bit, Wood drill bit	5	3	D-16405
	6	3	
	8	3	

17 pcs General Purpose Set



Type / Size		Pc/ Pkg	New Part No (With country of origin)
H.S.S. R Drill Bits	3, 4, 5, 6mm	4	D-40216
Masonry Drill Bits	4, 5, 6, 8mm	4	
25mm Long Screw Driver Bits	Philips: Ph1, Ph2	6	
	Slotted: S0.8, S1.2	2	
	Pozi: Pz2, Pz3	2	
	Torx: T20, T25	2	
Magnetic Bit Holder		1	
Plastic case			

26 pcs drill bits and Screwdriver bits set



Type		Pc/ Pkg	Part No
Masonry Bits, Sand blasted Finish	4, 5, 6, 8, 10, 12mm	6	P-90196
H.S.S. Drill Bits, with polish, fully ground	3, 4, 5, 6, 8, 10, 12mm	7	
Point Wood Bits	3, 4, 5, 6, 8, 10mm	6	
25mm Long Screw Driver Bits	Slotted: 4.5 & 6mm	2	
	Philips: Ph1 + Ph2	2	
	Pozi: Pz1 + Pz2	2	
Magnetic Bit Holder	60mm	1	
Roll-up nylon pouch with velcro closing			

32 pcs Maklok Accessory Pouch with belt clip

For use with 3 Jaw or Maklok chucks.



Type / Size	Part No
6x Nutdrivers, Size: 5/16" & 7/8/10/11/13mm	P-52021
16x 25mm(L) Bits, W/2pcs Plastic Holders, Size: 4x Hex: 3/4/5/6mm, 4x Slotted: 4/ 5/ 6/ 7mm 4x Torx: T10/ 15/ 20/ 25, 4x Pozi: PZ1/ 2/ 2/ 3	
4x Hex Shank H.S.S. Drill, titanium coated, Size: 4/ 5/5.5/6mm	
4x Hex Shank Masonry Drill, Size: 4/ 5.5/ 7/ 8mm	
1x Stubby Screw Guide	
1x Maklok Quick Change Chuck	
Pouch	

Pilot Drill and Grub Screws



Type / Size	Part No
5 x Replacement Pilot Drills, Size: #6 (3/32") 2 x Replacement Grub Screws	P-50289
5 x Replacement Pilot Drills, Size: #8 (7/64") 2 x Replacement Grub Screws	P-50295
5 x Replacement Pilot Drills, Size: #10 (1/8") 2 x Replacement Grub Screws	P-50304

'MACCESS series'

MACCESS

MACCESS series contains high quality items of screw bits, drill bits, hand tools, and so on.

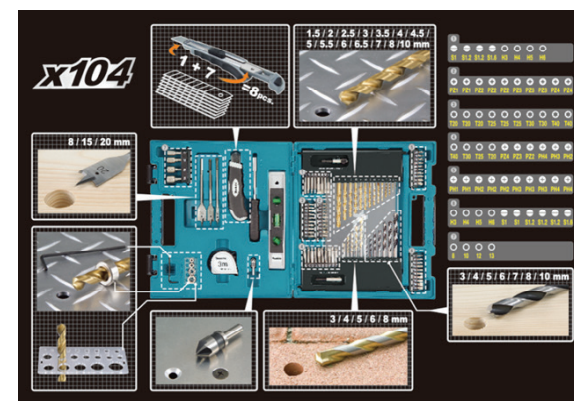
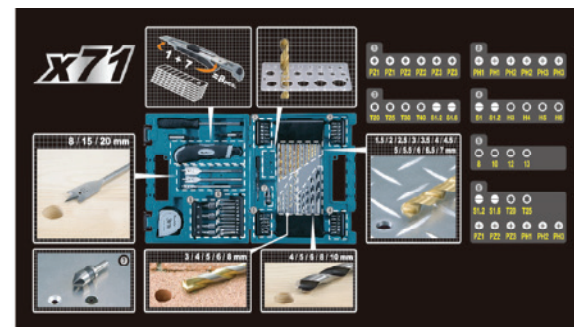
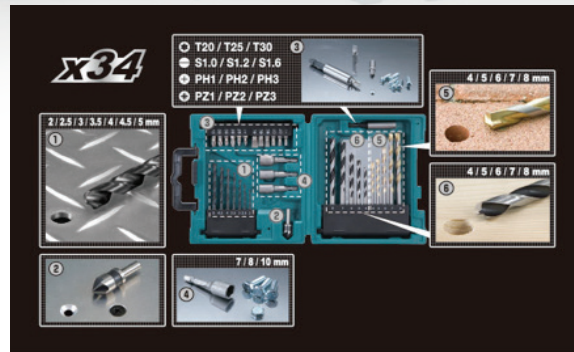

BATTERY / CHARGERS

FIXING FASTENING (SCREWDRIVER BITS / IMPACT SOCKETS)

DRILLING (WOOD / METAL/ MASONRY)

DRILLING / DEMOLITION (CONCRETE)

CUTTING (METAL)

MULTI TOOL ACCESSORIES

DIAMOND (CUTTING / GRINDING)

GRINDING ACCESSORIES

SANDING / POLISHING ACCESSORIES

SAWING ACCESSORIES

ROUTERS / PLANERS ACCESSORIES

CLEANERS ACCESSORIES

HEAT GUN / LASERS ACCESSORIES

BRAD NAILS/ PINS STAPLER









GARDEN TOOLS ACCESSORIES

HAND TOOLS / COMBINATION SETS

65pcs sds-plus rotary hammers drill bits set



- Part no: B-69478
- In makpac case
- Accessory set includes bits for drilling on metal, wood, masonry, screw bit and nutsetter for SDS-PLUS rotary hammer drill.

No.	DESC.	Image	Shank	Size (mm)	Total length (mm)			
1	HSS-TiN metal drill bit 135°Split point		SDS-PLUS (Short type)	3	90			
2				3.5	100			
3				4	105			
4				4.5	110			
5				5	116			
6				5.5	123			
7				6	123			
8				6.5	131			
9				4	105			
10	Brad point Wood drill		SDS-PLUS (Short type)	5	116			
11				6	123			
12				8	147			
13				10	163			
14	SDS-PLUS Hammer drill		SDS-PLUS	6	160			
15				7	160			
16				8	160			
17				10	160			
18				12	160			
19				25mm Screw bit		C-form	PH0	25
20							PH0	
21							PH 1	
22	PH 1							
23	PH 2							
24	PH 2							
25	PH 2							
26	PH 3							
27	PH 3							
28	PH 3							
29	PZ0							
30	PZ0							
31	PZ 1							
32	PZ 1							
33	PZ 2							
34	PZ 2							
35	PZ 2							
36	PZ 3							
37	PZ 3							
38	PZ 3							
39	Slotted 0.8x4.0							
40	Slotted 0.8x4.0							
41	Slotted 0.8x5.0							
42	Slotted 0.8x5.0							
43	Slotted 1.0 x 5.5							
44	Slotted 1.0 x 5.5							
45	Slotted 1.2 x 6.5							
46	Slotted 1.2 x 6.5							
47	Hex. 3							
48	Hex. 4							
49	Hex. 5							
50	Hex. 6							
51	T10							
52	T15							
53	T20							
54	T20							
55	T25							
56	T25							
57	T30							
58	T40							
59	Magnetic Nutsetter		C-form	8	48			
60				10				
61				12				
62				13				
63	HSS countersink		C-form	M6(12.7)	41			
64	SDS-PLUS Sleeve chuck bit holder		SDS-PLUS (Short type)	-	80			
65	Tape Measure			3m*19mm				

34 pcs Maccess Accessories set

MACCESS



Type / Size	New Part No (With country of origin)
7pcs HSS R Metal Drill Bits, Size: (2, 2.5, 3, 3.5, 4, 4.5, 5)mm	D-36996
5 x Masonry Drill Bits, Size: (4, 5, 6, 7, 8)mm	
5 x Wood Drill Bits, Size: (4, 5, 6, 7, 8)mm	
3pcs Philips Bits, Size: PH1-1pc, PH2-1pc, PH3-1pc	
3pcs Pozi Bits, Size: PZ1-1pc, PZ2-1pc, PZ3-1pc	
3pcs Slotted Bits, Size: 1-1pc, 1.2-1pc, 1.6-1pc	
3pcs Torx Bits, Size: T20-1, T25-1, T30-1	
3pcs Socket Wrench, Size: (7, 8, 10)mm	
1pc Magnet Bit Holder	
1pc Countersink	
Carrying Case	

71 pcs Maccess Accessories set

MACCESS



Type / Size	Part No	New Part No (With country of origin)
12 x HSS Metal Drill Bits (Titanium Coated) Size: (1.5, 2, 2.5, 3, 3.5, 4, 4.5, 5, 5.5, 6, 6.5, 7)mm	D-33691	D-37144
5 x Masonry Drill Bits Size: (3, 4, 5, 6, 8)mm		
5 x Wood Drill Bits Size: (4, 5, 6, 8, 10)mm		
3 x Flat Bits Size: (8, 15, 20)mm		
9 x Philips Bits (25mm) Size: PH1-3pcs, PH2-3pcs, PH3-3pcs		
9 x Pozi Bits (50mm) Size: PZ1-3pcs, PZ2-3pcs, PZ3-3pcs		
6 x Slotted Bits Size: (1- 1pc, 1.2- 3pcs, 1.6- 2pcs)mm		
4 x Allen Key screw Size: H3, H4, H5, H6		
Torx 6pcs Size: T20-2pcs, T25-2pcs, T30-1pc, T40-1pc		
Socket Wrench 4pcs Size: (8 10, 12, 13)mm		
Magnet Bit Holder (1)		
Counter Sink (1)		
Diameter Gauge Transparent (1)		
One Touch Bit Holder (1)		
Carpet Knife (1)		
Center Punch (1)		
Screw Driver (Hand Tool) (1) Size: 1/4" drive		
3-m Measuring tape (1)		
Carrying Case		

BATTERY /
CHARGERS

FIXING FASTENING
(SCREWDRIVER BITS
/ IMPACT SOCKETS)

DRILLING
(WOOD / METAL/
MASONRY)

DRILLING
/ DEMOLITION
(CONCRETE)

CUTTING
(METAL)

MULTI TOOL
ACCESSORIES

DIAMOND
(CUTTING / GRINDING)

GRINDING
ACCESSORIES

SANDING
/ POLISHING
ACCESSORIES

SAWING
ACCESSORIES

ROUTERS
/ PLANERS
ACCESSORIES

CLEANERS
ACCESSORIES

HEAT GUN / LASERS
ACCESSORIES

BRAD NAILS/ PINS
STAPLER

GARDEN TOOLS
ACCESSORIES

HAND TOOLS /
COMBINATION SETS

104 pcs Maccess Accessories set



Type / Size	New Part No (With country of origin)
14pcs HSS Metal Titan Drill Bits Size: (1.5, 2, 2.5, 3, 3.5, 4, 4.5, 5, 5.5, 6, 6.5, 7, 8, 10)mm	D-37150
5pcs Masonry Drill Bits Size: (3, 4, 5, 6, 8)mm	
7pcs Wood Drill Bits Size: (3, 4, 5, 6, 7, 8, 10)mm	
3pcs Flat Bits Size: (8, 15, 20)mm	
10pcs Philips Bits Size: PH1-2pcs, PH2-3pcs, PH3-3pcs, PH4-2pcs	
3pcs Philips Long Bits Size: PH2-1pc, PH3-1pc, PH4-1pc	
10pcs Pozi Bits Size: PZ1-2pcs, PZ2-3pcs, PZ3-3pcs, PZ4-2pcs	
3pcs Pozi Long Bits Size: PZ2-1pc, PZ3-1pc, PZ4-1pc	
6pcs Slotted Bits Size: 1-2pcs, 1.2-3pcs, 1.6-1pc	
4pcs Slotted Long bits Size: 1-1pc, 1.2-2pcs, 1.6-1pc	
4pcs Hex screw bits Size: H3, H4, H5, H6	
4pcs Hex Long screw bits Size: H3, H4, H5, H6	
9pcs Torx bits Size: T20-3pcs, T25-2pcs, T30-2pcs, T40-2pcs	
6pcs Torx Long Bits Size: T20-1pc, T25-1pc, T30-2pcs, T40-2pcs	
4pcs Socket Wrench Size: wSize: (8, 10, 12, 13)mm	
1pc Magnet Bit Holder	
Counter Sink	
Leveler	
Counter Chuck Holder	
1pc Knife	
1pc Screw Driver	
1pc 3m Measuring tape	
4pcs Depth Gauge Size: (8, 10, 12, 13)mm	
1pc Hex Wrench for depth gauge	
Carry Case	

103pcs Bit and Hand Tool Display Set (5 Set)

Comes as a pack of 5 sets



5 set package

Type / Size	Part No
14pcs Hole Saw (32, 38, 45, 54mm)	D-42341-5
1pc Hole Saw Arbor	
4pcs Depth Stop (3, 5, 8, 10mm)	
1pc Hex Key Wrench	
1pc Measure 3m	
1pc Long Nose Plier	
1pc Combination Plier	
1pc Adjustable Wrench	
3pcs Flat Bit (16/22/32mm)	
1pc Nail Hammer	
1pc Leveler	
1pc Diameter Gauge 1-10mm	
18pcs HSS-R Drill Bit (1, 1.5, 2x2pcs, 2.5, 3x2pcs, 3.5, 4x2pcs, 4.5, 5.5, 6, 6.5, 7, 8, 10mm)	
7pcs Masonry Drill Bit (3/4/5/5.5/6/7/8mm)	
7pcs Wood Drill Bit (3, 4, 5, 6, 7, 8, 10mm)	
40pcs Screw Driver Bit 25mm PH0x2pcs, PH1x2pcs, PH2x3pcs, PH3x3pcs PZ0x2pcs, PZ1x2pcs, PZ2x3pcs PZ3x3pcs S4x2pcs, S6x2pcs, S7x2pcs H3, H4, H5, H6, T10x2pcs, T15x2pcs, T20x2pcs, T25x2pcs, T30, T40	
8pcs Socket (5, 6, 7, 8, 9, 10, 11, 13mm)	
1pc Socket adaptor for 25mm Screwdriver	
1pc Counter Sink	
1pc Magnet Bit Holder	

- BATTERY / CHARGERS
- FIXING FASTENING (SCREWDRIVER BITS / IMPACT SOCKETS)
- DRILLING (WOOD / METAL / MASONRY)
- DRILLING / DEMOLITION (CONCRETE)
- CUTTING [METAL]
- MULTI TOOL ACCESSORIES
- DIAMOND [CUTTING / GRINDING]
- GRINDING ACCESSORIES
- SANDING / POLISHING ACCESSORIES
- SAWING ACCESSORIES
- ROUTERS / PLANERS ACCESSORIES
- CLEANERS ACCESSORIES
- HEAT GUN / LASERS ACCESSORIES
- BRAD NAILS/ PINS STAPLER
- GARDEN TOOLS ACCESSORIES
- HAND TOOLS / COMBINATION SETS

78 pcs Technician's Fixing Kit



Type / Size	Part No
1x 120mm Clear Magnetic Screw Guide	P-46492
2x Screw Finders	
7x HSS Drill, W/Hex Shank, Size: 1.5, 3.5, 4, 4.5, 5, 5.5, 6mm	
5x Masonry Drill W/Hex Shank, Size: 5, 6, 7, 8, 10mm	
5x Flats Bits, W/Hex Shank, Size: 16, 18, 22, 25, 32mm	
8x 1/4" Dr. 6pt Socket, W/Plastic Holder Size: 7/32, 1/4, 5/16, 3/8, 7/16, 11/32, 1/2, 9/16"	
8x 1/4" Dr. 6pt Socket, W/Plastic Holder Size: 5, 6, 7, 8, 9, 10, 11, 12mm	
20x 25mm Bit, W/Plastic Holder Size: 5x Poz: PZ0, PZ1, PZ2, PZ2, PZ3 3x Slotted: 3mm, 4mm, 5mm 2x Phillips: PH1, PH2, 5x Hex: 3, 4, 5, 5.5, 6mm 4x Torx: T10, T20, T25, T27 1x Bit Adaptor	
1x 1/4" Dr. Universal Joint	
1x 1/4" Dr. Ratchet Handle	
10x 50mm Bit, Size: 5x Poz: PZ1, PZ2, PZ2, PZ3, PZ3 2x Slotted: 4, 5mm, 3x Phillips: PH1, PH2, PH3	
1x 50mm(L) 1/4" x1/4" Bit Adapter	
1x Stubby Bit Driver W/Magnetic Tip	
1x 60mm Magnetic Bit Holder	
4x Hole Saw, Size: 16, 18, 20, 25mm	
1x Arbor Adapter,	
1x 1/4" Dr. 6" Flex. Extension	
1x Stud Finder Blow Molded Case	
Blow Moulded Case	

64 pcs Maklok Quick Change Acc. Set



Type / Size	Part No
1x Maklok Quick Change Chuck	P-52087
7x Hex Shank HSS Drill, Titanium Coated, Size: 3, 4, 5, 6, 7, 8, 10mm	
5x Hex Shank Flat Bits, Size: 16, 18, 22, 25, 32mm	
16x 25 mm(L) Screwdriver Bits, Size: 4x Poz: PZ0, PZ1, PZ2, PZ3 4x Phillips: PH0, PH1, PH2, PH3 4x Slotted: 3,4,5,6mm, 4x Hex: 3, 4, 5, 6mm	
10x Nutdrivers, Size: 5, 6, 7, 8, 9, 10, 11, 12, 13mm & 5/16"	
2x Bit Stoppers	
1x Countersink	
7x Hex Shank 3 Point Wood Drill, Size: 3, 4, 5, 6, 7, 8, 10mm	
7x Hex Shank Masonry Drill, Size: 3, 4, 5.5, 6, 7, 8, 10mm	
4x Depth Gauge, Size: 6, 8, 10, 12mm	
1x Allen Key, Size: 2.5mm	
1x 50mm Bit Adaptor, Size: 1/4" X1/4"	
1x 80mm(L) Screw Guide,	
1x Center Punch	
Blow Moulded Case	

BATTERY /
CHARGERSFIXING FASTENING
(SCREWDRIVER BITS
/ IMPACT SOCKETS)DRILLING
(WOOD / METAL/
MASONRY)DRILLING
/ DEMOLITION
(CONCRETE)CUTTING
(METAL)MULTI TOOL
ACCESSORIESDIAMOND
(CUTTING / GRINDING)GRINDING
ACCESSORIESSANDING
/ POLISHING
ACCESSORIESSAWING
ACCESSORIESROUTERS
/ PLANERS
ACCESSORIESCLEANERS
ACCESSORIESHEAT GUN / LASERS
ACCESSORIESBRAD NAILS/ PINS
STAPLERGARDEN TOOLS
ACCESSORIESHAND TOOLS /
COMBINATION SETS

- BATTERY / CHARGERS
- FIXING FASTENING (SCREWDRIVER BITS / IMPACT SOCKETS)
- DRILLING (WOOD / METAL/ MASONRY)
- DRILLING / DEMOLITION [CONCRETE]
- CUTTING [METAL]
- MULTI TOOL ACCESSORIES
- DIAMOND [CUTTING / GRINDING]
- GRINDING ACCESSORIES
- SANDING / POLISHING ACCESSORIES
- SAWING ACCESSORIES
- ROUTERS / PLANERS ACCESSORIES
- CLEANERS ACCESSORIES
- HEAT GUN / LASERS ACCESSORIES
- BRAD NAILS/ PINS STAPLER
- GARDEN TOOLS ACCESSORIES
- HAND TOOLS / COMBINATION SETS

79 pcs Technician's Kit



Type / Size	Part No
1x 120mm(L) Compact Screw Guide	P-52065
2x Screw Finders	
7x Hex Shank HSS Drill W/Titanium Coated Size: 1.5 /3.5 /4 /4.5 /5 /5.5 /6mm	
5x Hex Shank Masonry Drill, Size: 5.5/6/7/8/10mm	
5x Hex Shank Flat Bits, Size: 16/18/22/25/32mm	
8x 1/4" Dr. 6pt Socket, W/Plastic Holder, Size: 7/32, 1/4, 5/16, 3/8, 7/16, 11/32, 1/2, 9/16"	
8x 1/4" Dr. 6pt Socket, W/Plastic Holder, Size: 5/6/7/8/9/10/11/12mm	
1x Bit Adaptor	
1x 1/4" Dr. Universal Joint	
1x 1/4" Dr., Ratchet Handle	
19x 25mm(L) Screwdriver Bit, Size: 5x Pozzi: PZ0, PZ1, PZ2, PZ2, PZ3 5x Hex: 3/4/5/5.5/6mm, 2x Phillips: Ph1, Ph2, 3x Slotted: 3mm,4mm,5mm 4x Torx: T10/20/25/27,	
10 x 100mm(L) Screwdriver Bit, Size: 5-Pozzi: PZ1,PZ2,PZ2,PZ3,PZ3 2-Phillips: Ph1, Ph2 3- Slotted: 3/4/5mm	
1x 50mm(L) 1/4" X1/4" Bit Adaptor	
1- Stubby Bit Driver	
1- 60mm Magnetic Bit Holder	
4x Hole Saw (For Metal Cutting), Size: 16/18/20/25mm	
1x Arbor	
1 x Stud Finder	
1x 230mm Flexible Drive Shaft	
1x Maklok Quick Change Chuck	
Nylon Pouch	

85 pcs Maklok General Purpose Accessory Set



Type / Size	Part No
1x Maklok Quick Change Chuck	P-52071
46x 25mm Screwdriver Bits, With 8 Pieces Plastic Holders, Size: 14x Pozzi: Pz0x3pcs, Pz1x3pcs, Pz2x5pcs, Pz3x3pcs 8x Slotted: 4mmx2pcs, 5x2pcs, 6x2pcs, 7x2pcs 8x Hex: 3mmx2pcs, 4x2pcs, 5x2pcs, 6x2pcs 9x Phillips: Ph1x3pcs, Ph2x3pcs, Ph3x3pcs 7x Torx: T10, T15, T20, T25, T27, T30, T35	
4x Depth Gauge, Size: 6,8,10,12mm	
1x Allen Key, Size: 2.5mm	
9x Nutdrivers, Size: 5, 6, 7, 8, 9, 10, 11, 13 mm & 5/16"	
4x Flat Bit, Size: 16, 22, 25, 32mm	
1x Countersink	
9x HSS Drill, Titanium Coated, Size: 1.5, 2, 3, 3.5, 4, 4.5, 5, 6, 6.5mm	
1x Bit Stopper	
1x 50mm(L) Bit Adaptor, Size: 1/4" X1/4"	
1x 80mm(L) Clear Screw Guide	
7x Masonry Drill (150mm), Size: 4.5, 5, 5.5, 6, 6.5, 7, 8mm	
Blow Moulded Case	

96 pcs Power Drill Accessory Set With Zipper Case



Type / Size	Part No
1x 3.5m Tape Measure	P-46517
1x 8" Plastic Level	
1x Pencil	
6x Precision Screwdriver with Plastic Box, Size 2x Phillips: Ph0, Ph1 4x Slotted: 1.4, 2.0, 2.4, 3.0mm	
1x Clear Screw Guide	
1x 6" Long Nose Plier	
1x 6" Linesman Plier	
1x Utility Knife	
1x Stud Finder	
20x 25mm Bit, Size: 5x Slotted: 3, 4, 5, 6, 7mm 4x Phillips: Ph1, Ph2, Ph2, Ph3 4x Pozi: Pz1, Pz2, Pz2, Pz3 3x Torx: T15, T20, T25 3x Hex: 4mm, 6mm, 7mm & 1x Bit Adapter	
10x 50mm(L) Screwdriver Bits, Size: 3x Slotted: 4,5,6 mm 3xPhillips: PH1, PH2, PH3 2x Pozi: Pz1, Pz2 2x Hex: 4, 5mm	
1x 60mm Magnetic Extension	
1x Plastic Finder	
3x Drill Stopper, Size: 3, 6, 8mm	
4x Hole Saw, Size: 16, 18, 20, 25mm	
1x Arbor Adapter for Hole Saw	
1x Bit Driver, W/Ratchet	
1x 2.5 Hex Key	
14x Nutdrivers, Size: 7, 8, 9, 10, 11, 12, 13mm & 1/4, 9/32, 5/16, 11/32, 3/8, 7/16, 1/2"	
1x Quick Change Adapter	
7x Hex Shank HSS Drill Bits, Titanium Coated, Size: 4, 5, 6, 7, 8, 9, 10mm	
5x Hex Shank Masonry Drill, Size: 5.5, 6, 7, 8, 10mm	
1x 6.4mm Multi Drill	
1x 6" Flex Extension	
1x 50mm(L) 1/4" X1/4" Bit Adapter	
5x Flat Bits, W/Hex Shank, Size: 16,18,22,25,32mm	
5x Insulated Screwdriver, Size: 2x Slotted: 3x100mm, 6.5x150mm 3x Phillips: Ph0x75mm, Ph1x100mm, Ph2x100mm	
Zipper Case	

96 pcs Electrician's Tool Kit with Zipper case



Type / Size	Part No
6x Precision Screwdriver In Plastic Box, Size: 2x Phillips: Ph0, Ph1, 4x Slotted: 1.4, 2.0, 2.4, 3.0mm	P-51851
1x Utility Knife, 1x Stud Finder	
19x 25mm(L) Screwdriver Bits, Size: 5x Slotted: 3, 4, 5, 6, 7mm, 4x Phillips: PH1/2/2/3 4x Pozi: PZ1,PZ2x2pcs,PZ3 3x Torx: T15, T20, T25 3x Hex: 4mm, 6mm, 7mm	
2x Hex/Square Drive Adaptor (25mm and 50mm)	
10x 50mm(L) Screwdriver Bits, Size: 3x Slotted: 4mm, 5mm, 6mm 3x Phillips: PH1/2/3 2x Pozi: PZ1/2, 2x Hex: 4mm, 5mm	
1x 50mm Magnetic Extension, 1x Screw Finder	
3x Depth Gauge, Size: 3,6,8mm	
1x 2.5 Hex Key, 1x Holesaw Arbor	
4x BixMetal Holesaws For Metal Cutting, Size: 16, 18, 20, 25mm	
14x Nutdrivers, Size: (7, 8, 9, 10, 11, 12, 13)mm & (1/4, 9/32, 5/16, 11/32, 3/8, 7/16, 1/2)"	
1x Maklok Quick Change Chuck	
7x Hex Shank HSS Drill Bits, Titanium Coated Size: 4, 5, 6, 7, 8, 9, 10mm	
5x Hex Shank Masonry Drill, Size: 5.5, 6, 7, 8, 10mm	
1 x 150mm Diagonal nose plier, GS handle, 1000V	
1 x 150mm Linesman plier, GS handle 1000V	
5 x Insulated Screwdrivers GD handle 1000V Size: 2 pc Slotted 3 x 100mm. 6.5 x 150mm	
3 pc Phillips: Ph0x75mm, Ph1x100mm, Ph2x100mm	
1 Ratchet bit driver, 1 X 3.5M Measuring tape	
1 X 300mm Spirit level, 1 X Carpenter's pencil	
1 X Clear screw guide, , 1x 150mm Drive Extension	
1x 6.4mm Drill Saw, Titanium Coated	
5x Hex Shank Flat Bits, Size: 16, 18, 22, 25, 32mm	
Zipper Case	

BATTERY /
CHARGERSFIXING FASTENING
(SCREWDRIVER BITS
/ IMPACT SOCKETS)DRILLING
(WOOD / METAL/
MASONRY)DRILLING
/ DEMOLITION
[CONCRETE]CUTTING
[METAL]MULTI TOOL
ACCESSORIESDIAMOND
[CUTTING / GRINDING]GRINDING
ACCESSORIESSANDING
/ POLISHING
ACCESSORIESSAWING
ACCESSORIESROUTERS
/ PLANERS
ACCESSORIESCLEANERS
ACCESSORIESHEAT GUN / LASERS
ACCESSORIESBRAD NAILS/ PINS
STAPLERGARDEN TOOLS
ACCESSORIESHAND TOOLS /
COMBINATION SETS

- BATTERY / CHARGERS
- FIXING FASTENING (SCREWDRIVER BITS / IMPACT SOCKETS)
- DRILLING (WOOD / METAL/ MASONRY)
- DRILLING / DEMOLITION (CONCRETE)
- CUTTING [METAL]
- MULTI TOOL ACCESSORIES
- DIAMOND [CUTTING / GRINDING]
- GRINDING ACCESSORIES
- SANDING / POLISHING ACCESSORIES
- SAWING ACCESSORIES
- ROUTERS / PLANERS ACCESSORIES
- CLEANERS ACCESSORIES
- HEAT GUN / LASERS ACCESSORIES
- BRAD NAILS/ PINS STAPLER
- GARDEN TOOLS ACCESSORIES
- HAND TOOLS / COMBINATION SETS

99 pcs Power Tool Accessory Set



Type / Size	Part No
14x Nutdrivers, Size: (1/4, 9/32, 5/16, 11/32, 3/8, 7/16, 1/2)" & (6, 7, 8, 9, 10, 11, 12)mm	P-51910
1x Countersink	
13x High Speed Drill Bits with Titanium Coated, Size: 1, 1.5, 2, 2.5, 3, 3.5, 4, 4.5, 5, 5.5, 6, 6.5, 7mm	
10x Masonry Drill Bits, Size: 3, 4, 5, 5.5, 6, 6.5, 7, 8, 9, 10mm	
20x 50mm(L) Screwdriver, Size: 4x Slotted: 4.0, 4.5, 7.0, 8.0 mm 3x Pozzi: Pz1, Pz2, Pz3, 3x Phillips: #1, #2, #3 6x Torx: T10, 15, 20, 25, 30, 40 4x Hex: 3.0, 4.0, 5, 5.5 mm 5x 3 Point Wood Bits, Size: 3, 5, 6, 8, 10mm	
30x 25mm(L) Bits with 3pcs Plastic Holder, Size: 3x Phillips: #1, #2, #3 7x Pozzi: Pz1x2pcs, Pz2x3pcs, Pz3x2pcs 6x Torx: T10, 15, 20, 25, 27, 30 4x Hex: 4, 5, 6, 7mm 10x Slotted: 3.0 mm x 2 pcs, 4.0 mm x 2 pcs, 4.5 mmx2 pcs, 6.0 mm x2 pcs, 7.0 mm, 8.0 mm	
1x 60mm Magnetic Bit Holder	
2x Screw Finders	
3x Depth Gauge, Size: 3/5/6mm	
Nylon Pouch	

102 pcs Drill and Screwdriver bit set



Type / Size	Part No
1x 60mm Magnetic Bit Holder	P-52037
3x Flat Bits, Size: 12/16/19mm	
5x Masonry Drill Bits, Size: 4/5.5/7/8/10mm	
1x Counter Sink	
13x High Speed Drill Bits, W/Titanium Coated Size: 1/1.5 /2 /2.5 /3 /3.2 /3.5 /4 /4.2 /4.5 /5 /5.5 /6mm	
14x Nutdrivers, Size: 5/32, 7/32, 1/4, 9/32, 5/16, 3/8, 7/16" & 5, 6, 7, 8, 9, 10, 11mm	
5x Hole Saw (For Wooden Cutting), Size: 32/38/45/54mm With 1pc Holesaw Arbor	
1x Center Punch, Size: 1/4", 3-7/8" L	
1x Screwdriver Handle	
32x 25mm(L) Screwdriver Bits, W/4pcs Pvc Holder Size: 8x Hex: 3 /4 /4 /5 /5.5 /6 /6 /7mm 8x Pozzi: PZ0/0/1/1/2/2/3/3, 4x Slotted: 3/4/5/6mm 4x Phillips: Ph0/1/2/3 8x Torx: T10/15/20/25/27/30/35/40	
16x 50mm(L) Screwdriver Bits, With 2pcs Plastic Holders 4x Pozzi: PZ1, PZ2x2PCS, PZ3, 4x Slotted: 3, 4, 5, 6mm 3x Phillips: PH1, PH2, PH3, 3x Hex: 3, 4, 5mm	
2x Bit Holder (Round Type),	
1x 200mm Spirit Level	
6x 3 Point Wood Drill, Size: 3/4/5/6/7/8mm	
2x Screw Finders	
1x 3.5m Measuring Tape	
Blow Moulded Case	

138 pcs Power drilling / Screw driving set with storage bin



Type / Size	Part No
1x Center Punch	P-46501
4x Depth Stops, Size: 6, 8, 10, 12mm	
1x 3.2mm Hex Key	
2x Glass And Tile Bit W/Hex Shank, Size: 5.5,7mm	
4x Wood Drilling Bits W/Hex Shank, Size: 5.5,7,8,10mm	
5x Flat Bits, W/Hex Shank, Size: 10,12,20,22,25mm	
4x 150mm(L) Masonry Drill W/Hex Shank, Size: 5.5, 7, 8, 10mm	
1x 6.4mm Drill / Saw Bit,	
1x Arbor Adapter for Hole Saw	
21x H.S.S. Drill W/Hex Shank, Size: 1.5mmx2pcs, 2mmx3pcs, 3mmx3pcs, 4mmx3pcs, 5mmx3pcs, 6mmx3pcs, 7mmx2pcs, 8mmx2pcs,	
1x Quick Change Adapter	
1x 20cm Spirit Level	
1x Ratchet Bit Driver (Magnetic)	
7x 50mm BIT, W/Plastic Holder, Size: 2x Slotted: 4, 5mm 3x Hex: 4, 5, 7mm 2x Square: S1, S2	
7x 50mm Bit, W/Plastic Holder, Size: 3x Poz: Pz1, Pz2, Pz2 2x Torx: T15, T20 2x Philips: Ph1, Ph2	
3x Bit Stoppers	
1x 1/2" Square Drive Adaptor	
1x 3/8" Square Drive Adaptor	
1x 1/4" Square Drive Adaptor	
9x 4-Way Driver Barrel Complete With Body,	
4 Pilot Drill Assemblies And Poz: 2 Bit Size: No.8, No.8, No10, No.12,	
48x 25mm(L) Bit, Size: 3x Square: S1, S2, S3 9x Hex: 4mmx2pcs, 5mmx3pcs, 6mmx2pcs, 7mmx2pcs 5x Phillips: PH0, PH1, PH2x2pcs, PH3 11x Poz: Pz0 x 2pcs, Pz1 x 3pcs, Pz2 x 3pcs, Pz3 x 3pcs 10x Slotted: 4mmx2ps, 5mmx3pcs, 6mmx2pcs, 7mmx3pcs 10x Torx: T10, T15, T20x2pcs, T25x2pcs, T27, T30, T35, T40	
10x Sockets Size: 5,5.5,6,7,8,9,10,11,12,13mm	
1 x Stubby Screw Guide	
1x75mm(L) Magnetic Extension	
1x80mm(L) Magnetic Clear Screw Guide	
Blow Molded Case With Drawer2mm	

BATTERY /
CHARGERSFIXING FASTENING
(SCREWDRIVER BITS
/ IMPACT SOCKETS)DRILLING
(WOOD / METAL/
MASONRY)DRILLING
/ DEMOLITION
(CONCRETE)CUTTING
(METAL)MULTI TOOL
ACCESSORIESDIAMOND
(CUTTING / GRINDING)GRINDING
ACCESSORIESSANDING
/ POLISHING
ACCESSORIESSAWING
ACCESSORIESROUTERS
/ PLANERS
ACCESSORIESCLEANERS
ACCESSORIESHEAT GUN / LASERS
ACCESSORIESBRAD NAILS/ PINS
STAPLERGARDEN TOOLS
ACCESSORIESHAND TOOLS /
COMBINATION SETS

Carbon Brushes

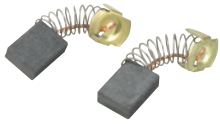

High Volt CB No.	Part No.	New Part No (With country of origin)	Low Volt CB No.	Part No.	New Part No (With country of origin)	
1	181019-9	194961-5	1	181019-9	194961-5	
51		194963-1	76	191947-0	-	
55	181026-2	194964-9	75	191956-9	-	
64		194968-1	75	191956-9	-	
65		194969-9	76	191947-0	-	
70	191914-5	194970-4	70	191914-5	194970-4	
85	191998-3	194973-8	75	191956-9	-	
100		194974-6	124	191945-4	-	
106		194976-2	107	181437-1	-	
132	191972-1	194984-3	132	191972-1	194984-3	
153		194985-1	154		194986-9	
154		194986-9	154		194986-9	
165	191936-5	-	166		-	
203		194991-6	203		194991-6	
253	194547-5	194994-0	253	194547-5	194994-0	
303		194996-6	303		194996-6	
325		195001-2	325		195001-2	
411	191940-4	195010-1	408	191938-1	195008-8	
414	191949-6	-	414	191949-6	-	
415	191950-1	195012-7	401	191910-3	195005-4	
419		195015-1	407	191927-6	-	
459		195026-6	458	194721-5	-	

Auto Cut- out Carbon Brush

105		194975-4	105		194975-4	
155	181048-2	194987-7	155	181048-2	194987-7	
175		195845-0	175		195845-0	
204		194992-4	204		194992-4	
327		195003-8	304		194997-4	
318		194999-0	318		194999-0	
350		195004-6	350		195004-6	

Carbon Brush for Cordless tool

424	191966-6	-	424	191966-6	-	
430		195018-5	430		195018-5	
434	193466-2	-	434	193466-2	-	
440		195021-6	440		195021-6	
441		195022-4	441		195022-4	
442	194928-3	195023-2	442	194928-3	195023-2	
448	196854-2	-	448	196854-2	-	

