

Model No.UH4520 HEDGE TRIMMER 450MM

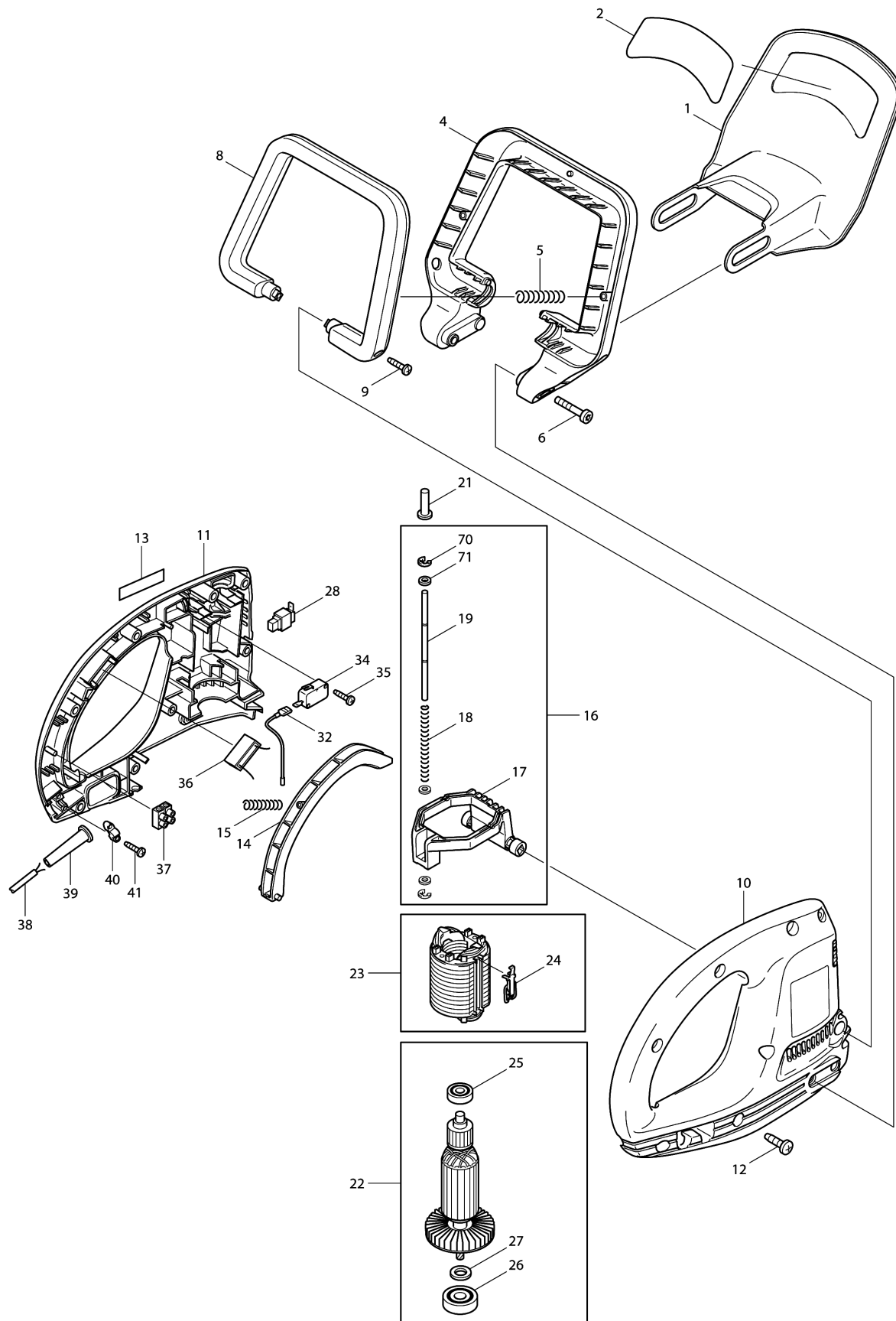

Model No.UH4520 HEDGE TRIMMER 450MM

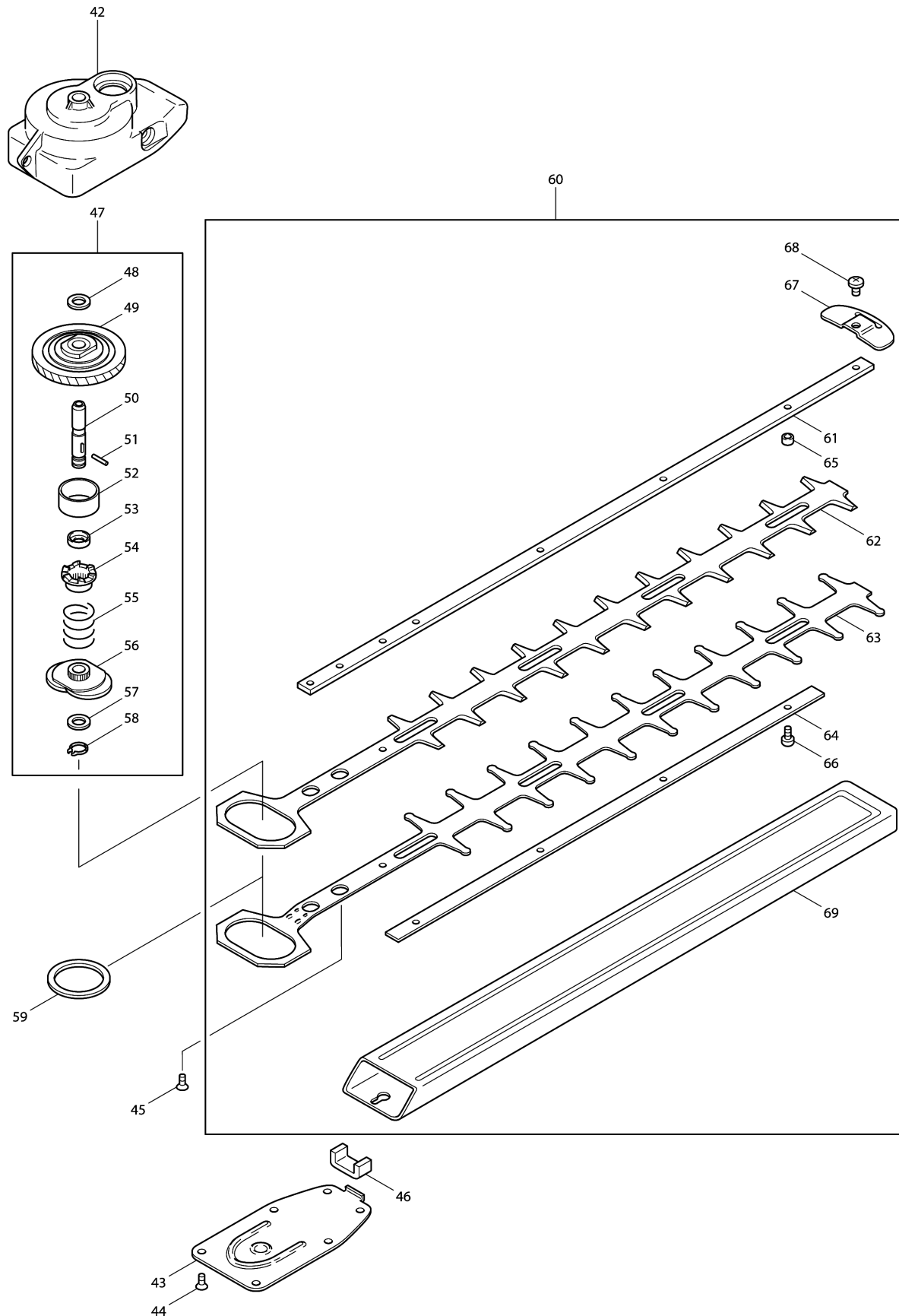

Model No.UH4520 HEDGE TRIMMER 450MM

Item	Parts No.	Description	I/C	Qty	New/Old	Opt. 1	Opt. 2	Note
001	220213110	HAND GUARD		1				
002	980114292	CAUTION LABEL		1				
004	220310110	TUBULAR HANDLE		1				
005	220145110	PRESSURE SPRING		2				
006	908005305	H.L. SOCKET HEAD BOLT M5X30		2				
008	220144110	FRONT GRIP SWITCH		1				
009	915635164	SELF-CUTTING SCREW M3.5X16		2				
010	220110611	CASE CPL.		1				
D10		INC. 11						
011	220110611	CASE CPL.		1				
D10		INC. 10						
012	913455204	H.L.TAPPING SCREW 5.5X20		8	*			
012-1	913455204	H.L.TAPPING SCREW 5.5X20	O	8				
013	980114296	LABEL		1				
014	220144120	REAR GRIP SWITCH		1				
015	220145120	PRESSURE SPRING		1				
016	220144300	REPAIR KIT SWITCH FORK		1				
D10		INC. 17-19,42,43						
017	220144130	SWITCH FORK		1				
018	220145130	PRESSURE SPRING		1				
019	220144140	SWITCH ROD		1				
021	220144150	CUP		1				
022	970800730	ROTOR ASSY. 230V		1				
D10		INC. 25-27						
023	970800830	STATOR ASSY. 230V		1				
D10		INC. 14						
024	970800610	CLAMP		2				
025	960101074	BALL BEARING		1				
026	960102104	BALL BEARING		1				
027	220229320	WASHER 10/15.8X0.5		1				
028	957800410	CARBON BRUSH CPL.		2				
034	970001190	SWITCH		1				
035	914529194	SCREW		1				
036	970109890	CAPACITOR		1				
037	970201220	SCREW WIRE CONNECTOR		1				
038	970102110	CABLE WITH PLUG		1				
039	204152010	CORD GUARD		1				
040	203152050	TRACTION RELIEF		1				
041	915635164	SELF-CUTTING SCREW M3.5X16		2				
042	220211011	GEAR HOUSING		1				
D10		INC. 50						

Please order the parts with part number.

Print Date 4/7/2019

Model No.UH4520 HEDGE TRIMMER 450MM

Item	Parts No.	Description	I/C	Qty	New/Old	Opt. 1	Opt. 2	Note
043	220212110	GEAR COVER		1				
044	908105126	H.L.S. FLAT HEAD BOLT M5X12		6				
045	908105126	H.L.S. FLAT HEAD BOLT M5X12		2				
046	965404860	GASKET		1				
047	220220011	GEAR CPL.		1				
D10		INC. 48-58						
048	220229220	WASHER 10.2/15.8X0.3		1				
049	220229011	SLIP CLUTCH CPL.		1				
050	220229211	BUSH		1				
051	220229230	ACTIVATION PIN		1				
052	220229240	DISTANGE PIECE		1				
053	220229250	SPRING GUIDING HEAD		1				
054	220229121	CLAWCOUPLING		1				
055	220229150	PRESSURE SPRING		1				
056	220229021	ECCENTRIC CPL.		1				
057	220229220	WASHER 10.2/15.8X0.3		1				
058	929110100	SNAP RING		1				
059	220229200	WASHER 40/54X1.4		1				
060	220230646	SHEAR BLADE 45CM		1				
D10		INC. 61-69						
061	220233111	MOUNTING BAR 45CM		1				
062	220233210	SHEAR PLATE A 45CM		1				
063	220233310	SHEAR PLATE B 45CM		1				
064	220233410	BAR 45CM		1				
065	220233150	DISTANCE PIECE		4				
066	220233160	SCREW M5X10		4				
067	220233170	GUARD		1				
068	220233090	SCREW M6X6		1				
069	220233610	SHEATH 40-48CM		1				
070	927303200	SAFETY WASHER		2				
071	900006054	WASHER		3				

Please order the parts with part number.

Print Date 4/7/2019