

Model No.RBC2110 STRING TRIMMER

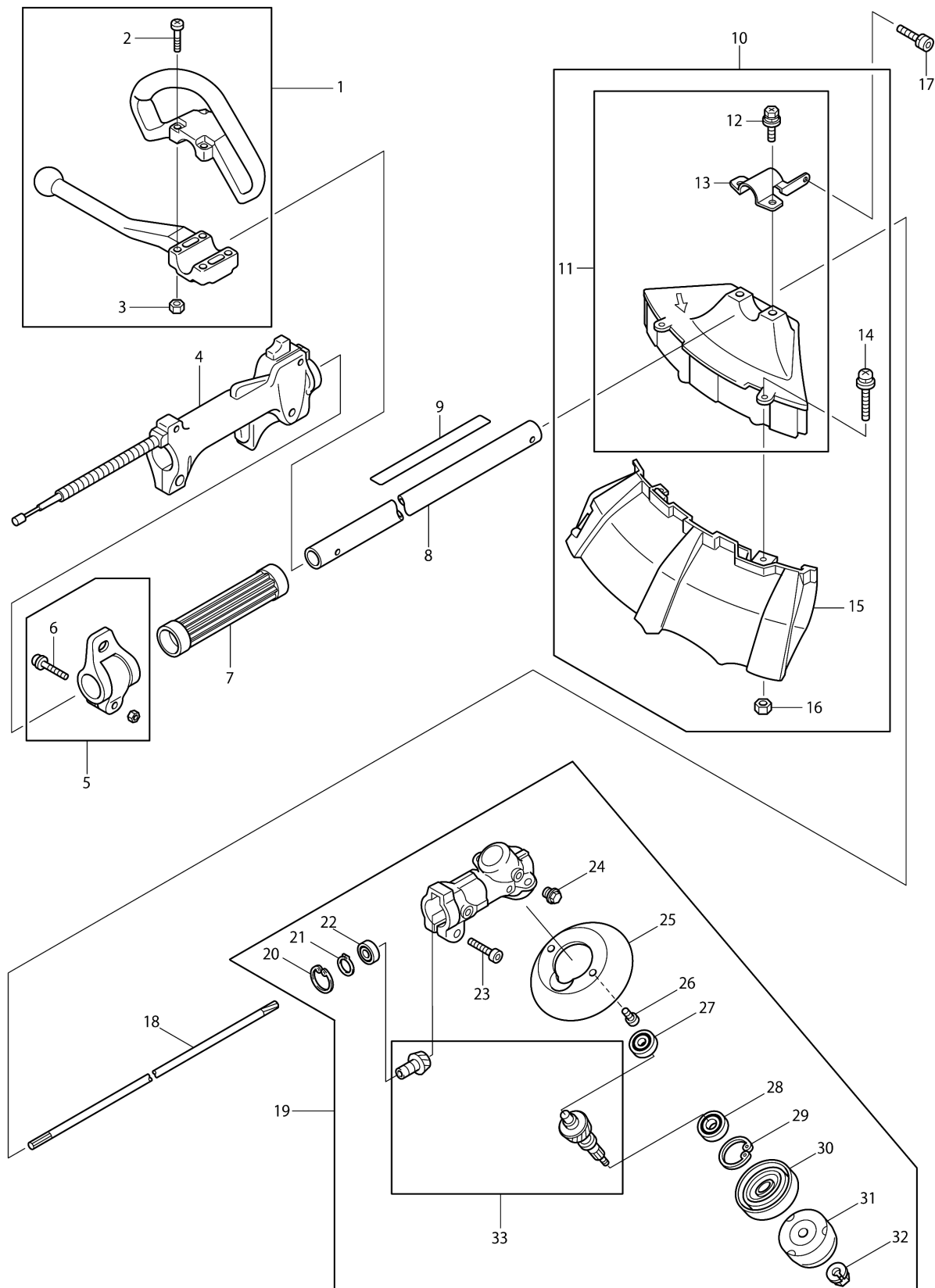

Model No.RBC2110 STRING TRIMMER

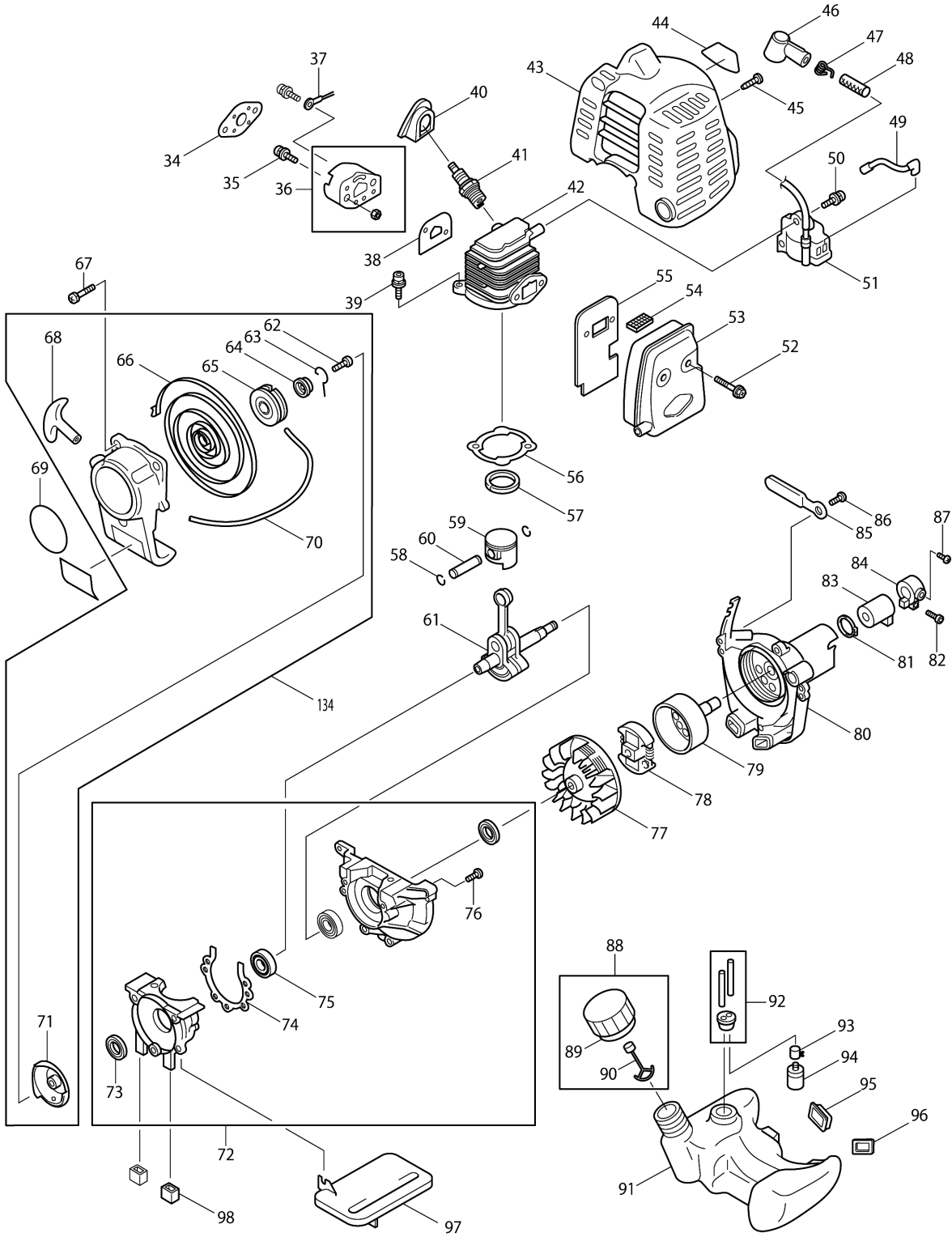

Model No.RBC2110 STRING TRIMMER

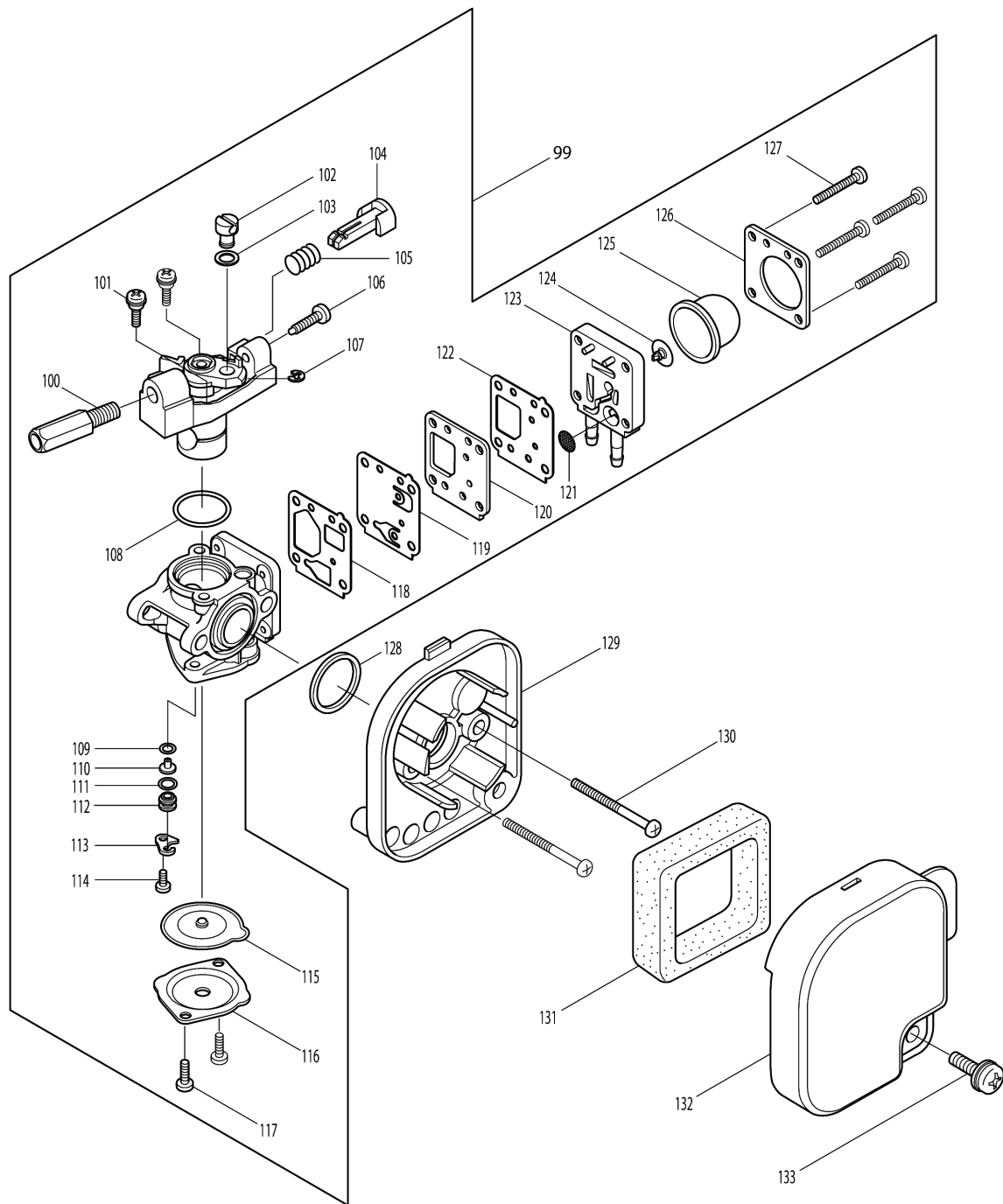

Model No.RBC2110 STRING TRIMMER

Item	Parts No.	Description	I/C	Qty	New/Old	Opt. 1	Opt. 2	Note
001	6214017000	HANDLE COMPLETE		1	*			
D10		INC. 2,3			*			
001-1	6214016000	HANDLE SET	X	1	*			
D10		INC. 2,3			*			
001-2	125567-8	HANDLE ASSEMBLY	O	1				
D10		INC. 2,3						
002	6214016030	SCREW		4	*			
002-1	266845-8	BINDING HEAD SCREW M5X25	O	4				
003	0022705000	NUT M5		4	*			
003-1	264093-3	HEX. NUT M5	O	4	*			
003-2	931202-6	HEX. NUT M5	O	4				
004	6195021000	CONTROL LEVER ASS'Y		1	*			
004-1	6195026000	CONTROL LEVER ASS'Y	S	1				
005	6197005001	HANGER ASS'Y		1	*			
D10		INC. 6			*			
005-1	126378-4	HANGER ASS'Y	O	1				
D10		INC. 6						
006	0140059360	SCREW & WASHER ASS'Y		1	*			
006-1	266788-4	PAN HEAD SCREW M5X20 WITH WR	O	1				
007	6271501501	SPACER		1	*			
007-1	450659-7	SPACER	O	1				
008	6191001001	SHAFT PIPE COMPLETE		1	*			
008-1	141986-0	SHAFT PIPE COMPLETE	O	1				
009	6199519800	CAUTION LABEL		1	*			
009-1	800N21-4	CAUTION LABEL	<	1				
010	6198014000	PROTECTOR ASS'Y		1	*			
D10		INC. 11,14-16			*			
010-1	6198014001	PROTECTOR ASS'Y	O	1				
D10		INC. 11,14-16						
011	6258061001	PROTECTOR ASS'Y		1	*			
D10		INC. 12,13			*			
011-1	6258061002	PROTECTOR ASSY	O	1				
D10		INC. 12,13,136						
012	0100069790	BOLT M6X30		2	*			
012-1	0100069770	BOLT,CROSSRECESS	O	2	*			
012-2	266617-1	CROSS-RECESSED HEAD BOLT M6X23	O	2				
013	6258508200	PROTECTOR CLAMP		1	*			
013-1	346493-0	PROTECTOR CLAMP	O	1				
014	0140059380	SCREW ASSEMBLY		2				
015	6198008001	PROTECTOR COMPLETE		1				
016	0021805000	NUT M5		2	*			

Please order the parts with part number.

Print Date 4/7/2019

Model No.RBC2110 STRING TRIMMER

Item	Parts No.	Description	I/C	Qty	New/Old	Opt. 1	Opt. 2	Note
016-1	264035-7	HEX. NUT M5	O	2				
017	0119059490	SOCKET HEAD BOLT M5X14 (W,SW)		1				
018	6191500401	SHAFT		1	*			
018-1	324893-4	SHAFT	O	1				
019	6243500600	GEAR CASE		1	*			
D10		INC. 20-33			*			
019-1	6243006002	CASE,GEAR ASSY	X	1	*			
D10		INC. 20-33			*			
019-2	125476-1	GEAR CASE ASSEMBLY	O	1				
D10		INC. 20-33						
020	0031424000	INNER SNAP RING		1	*			
020-1	257987-9	RETAINING RING (INT)R-24	O	1				
021	6193006120	OUTER SNAP RING		1	*			
021-1	257986-1	RETAINING RING (EXT) S-9	O	1				
022	6212500300	BALL BEARING #609ZZ		1	*			
022-1	210049-4	BALL BEARING 609ZZ	O	1				
023	0119059890	SOCKET HEAD BOLT M5X25		1	*			
023-1	266805-0	H.S.H.BOLT M5X25 WITH W	O	1				
024	6253011012	OIL BOLT M6X9		1	*			
024-1	265578-2	+HEX.BOLT M6X8	O	1				
025	6218500200	GUARD		1	*			
025-1	450653-9	GUARD	O	1				
026	0140059390	SCREW ASSEMBLY		2	*			
026-1	265195-8	+PAN HEAD SCREW M5X12	O	2				
027	0600069990	BALL BEARING 626ZZ		1	*			
027-1	210083-4	BALL BEARING 626	O	1				
028	0600109910	BALL BEARING 6000DDU		1	*			
028-1	210082-6	BALL BEARING 6000DDU	O	1				
029	0031426000	INNER SNAP RING		1	*			
029-1	257988-7	RETAINING RING (INT) R-26	O	1				
030	6218501601	RECEIVE WASHER		1	*			
030-1	6218500000	RECEIVE WASHER	O	1	*			
030-2	332042-9	RECEIVE WASHER	O	1				
031	6218003001	CLAMP COMPL. WASHER		1	*			
031-1	168481-5	CLAMP WASHER COMPLETE	O	1	*			
031-2	168797-8	CLAMP WASHER COMPLETE	O	1				
032	6258505001	NUT		1	*			
032-1	264018-7	HEX.NUT M8	O	1				
033	6243008002	CUTTER SHAFT SET		1	*			
033-1	195350-7	CUTTER SHAFT SET	O	1				
034	5103502801	SPACER GASKET		1	*			
034-1	442177-9	GASKET AIR CLEANER	O	1				

Please order the parts with part number.

Print Date 4/7/2019

Model No.RBC2110 STRING TRIMMER

Item	Parts No.	Description	I/C	Qty	New/Old	Opt. 1	Opt. 2	Note
035	0140059500	SCREW M5X25		2	*			
035-1	266700-4	PAN HEAD SCREW M5X25	O	2				
036	5233014000	INSULATOR COMPL.		1	*			
036-1	141056-5	INSULATOR COMPLETE	O	1				
037	6165500201	WIRE		1	*			
037-1	638784-6	WIRE	O	1				
038	5193500500	INSULATOR GASKET		1	*			
038-1	5193500501	INSULATOR GASKET	O	1	*			
038-2	442175-3	INSULATOR GASKET	O	1				
039	0119059730	SOCKET HEAD BOLT M5X20		2	*			
039-1	266814-9	HEX SOCKET HEAD BOLT M5X20	O	2				
040	5197500100	PLUG CAP COVER		1	*			
040-1	424445-2	PLUG CAP COVER	O	1				
041	0650149661	SPARK PLUG		1	*			
041-1	168648-5	SPARK PLUG (BPMR7A)	O	1				
042	5191500901	CYLINDER		1	*			
042-1	318785-7	CYLINDER	O	1				
043	5195503000	COVER,CYLINDER HD		1	*			
043-1	452973-7	CYLINDER COVER	O	1	*			
043-2	455795-4	CYLINDER COVER	S	1				
044	6279505700	TRADE MARK LABEL "MAKITA"		1	*			
045	0150059790	TAPPING SCREW 5X14		1	*			
045-1	266702-0	TAPPING SCREW 5X14	O	1				
046	0655009870	PLUG CAP		1	*			
046-1	424337-5	PLUG CAP	O	1				
047	0654009931	PLUG CAP SPRING		1	*			
047-1	324891-8	PLUG CAP SPRING	O	1				
048	0851089950	TUBE		1	*			
048-1	444021-6	TUBE	O	1				
049	5197018000	WIRE COMPL		1	*			
049-1	141049-2	WIRE COMPLETE	O	1				
050	0140049770	SCREW ASSY M4X16(W,SW)		2				
051	5197011010	IGNITION COIL		1	*			
051-1	168683-3	IGNITION COIL	O	1				
052	0119059520	SOCKET HEAD BOLT M5X40		2	*			
052-1	266440-4	HEX SOCKET HEAD BOLT M5X40	O	2				
053	5193001002	EXHAUST MUFFLER		1	*			
053-1	168679-4	EXHAUST MUFFLER	O	1				
054	5193001050	SPARK ARRESTER		1				
055	5193500002	INSULATOR,MUFFLER		1	*			
055-1	168680-9	MUFFLER GASKET	O	1				

Please order the parts with part number.

Print Date 4/7/2019

Model No.RBC2110 STRING TRIMMER

Item	Parts No.	Description	I/C	Qty	New/Old	Opt. 1	Opt. 2	Note
056	5191500301	CYLINDER GASKET		1	*			
056-1	442173-7	CYLINDER GASKET	O	1				
057	5212500500	PISTON RING		1	*			
057-1	257320-5	PISTON RING	O	1				
058	0565089970	CLIP		2	*			
058-1	233976-8	CLIP	O	2				
059	5192501701	PISTON		1	*			
059-1	318831-6	PISTON	O	1				
060	5192500500	PISTON PIN		1	*			
060-1	268277-5	PISTON PIN	O	1				
061	5192001002	CRANKSHAFT COMPL		1	*			
061-1	5192001003	CRANKSHAFT COMPLETE	O	1	*			
061-2	141047-6	CRANK SHFT COMPLETE	O	1				
062	5195002060	SET SCREW		1	*			
062-1	266585-8	TAPPING SCREW 5X12	O	1				
063	5195002100	SWING ARM		1	*			
063-1	325923-4	SWING ARM	O	1				
064	5195002110	COLLAR		1	*			
064-1	451938-6	COLLAR	O	1				
065	5195002030	REEL		1	*			
065-1	452972-9	REEL	O	1				
066	5195002050	SPIRAL SPRING		1	*			
066-1	234220-6	SPIRAL SPRING	O	1				
067	0140049770	SCREW ASSY M4X16(W,SW)		3				
068	5225004020	HANDLE		1	*			
068-1	424319-7	STARTER KNOB	O	1				
069	6199520100	MODEL LABEL		1				
070	5255016020	STARTER ROPE		1	*			
070-1	444024-0	STARTER ROPE	O	1				
071	5195500000	PULLEY		1	*			
071-1	168483-1	PULLEY	O	1				
072	5191004001	CRANK CASE ASS'Y		1	*			
D10		INC. 73-76			*			
072-1	123988-8	CRANK CASE ASSEMBLY	S	1				
D10		INC. 73-76						
073	0440109980	OIL SEAL		2	*			
073-1	213638-4	OIL SEAL	O	2				
074	5191500400	CRANKCASE GASKET		1	*			
074-1	442174-5	CRANK CASE GASKET	O	1				
075	0600109980	BALL BEARING 6000		2	*			
075-1	210086-8	BALL BEARING 6000	O	2	*			
075-2	211064-1	BALL BEARING 6000	O	2				

Please order the parts with part number.

Print Date 4/7/2019

Model No.RBC2110 STRING TRIMMER

Item	Parts No.	Description	I/C	Qty	New/Old	Opt. 1	Opt. 2	Note
076	0140059520	SCREW M5X25		3	*			
076-1	266701-2	PAN HEAD SCREW M5X25	O	3	*			
076-2	922241-7	HEX. SOCKET HEAD BOLT M5X25	O	3				
077	5197017010	FLYWHEEL		1	*			
077-1	318791-2	FLY WHEEL	O	1				
078	6192002003	CLUTCH		1	*			
078-1	168818-6	CLUTCH	O	1				
079	6192001001	CLUTCH DRUM COMPLETE		1	*			
079-1	161477-5	CLUTCH DRUM COMPLETE	O	1				
080	6195004002	CLUTCH CASE COMPLETE		1				
081	0031510000	OUTER SNAP RING 10		1	*			
081-1	961006-2	RETAINING RING S-10	O	1				
082	0119059880	SOCKET HEAD BOLT M5X25		1	*			
082-1	266712-7	HEX SOCKET HEAD BOLT M5X25	O	1				
083	6191500203	PIPE DAMPER		1	*			
083-1	424461-4	PIPE DAMPER	O	1				
084	6191501300	PIPE BRACKET		1	*			
084-1	318792-0	PIPE BRACKET	O	1				
085	0566059980	CLAMP		1	*			
085-1	345963-6	CLAMP	O	1				
086	0150059780	TAPPING SCREW M5X20		3	*			
086-1	266713-5	TAPPING SCREW 5X20	O	3	*			
086-2	911233-1	PAN HEAD SCREW M5X20	S	3				
087	0119059850	SOCKET HEAD BOLT M5X14		1	*			
087-1	266711-9	HEX SOCKET HEAD BOLT M5X14	O	1				
088	5256059000	FUEL TANK CAP COMPLETE		1	*			
D10		INC. 89,90			*			
088-1	168668-9	FUEL TANK CAP COMPLETE	O	1				
D10		INC. 89,90						
089	5256058000	FUEL TANK CAP		1	*			
089-1	452920-8	FUEL TANK CAP	O	1				
090	5256067000	STRAP		1	*			
090-1	140436-2	STRAP COMPLETE	O	1				
091	5196500003	FUEL TANK		1	*			
091-1	452989-2	FUEL TANK	O	1				
092	0851159920	TUBE		1	*			
092-1	0851159850	TUBE	O	1	*			
092-2	162329-3	TUBE	O	1				
093	0561059990	HOSE CLAMP		1	*			
093-1	345920-4	HOSE CLAMP	O	1				
094	5236503900	FILTER		1	*			

Please order the parts with part number.

Print Date 4/7/2019

Model No.RBC2110 STRING TRIMMER

Item	Parts No.	Description	I/C	Qty	New/Old	Opt. 1	Opt. 2	Note
094-1	163447-0	FUEL FILTER	O	1	*			
094-2	163447-0	FUEL FILTER	O	1				
095	5036500200	PLATE		1	*			
095-1	424102-2	PLATE	O	1				
096	5036500300	PLATE		1	*			
096-1	424103-0	PLATE	O	1				
097	5193500101	PLATE		1	*			
097-1	452988-4	MUFFLER PLATE	O	1				
098	5216500200	DAMPER		2	*			
098-1	424446-0	DAMPER	O	2				
099	5196036000	CARBURETOR		1	*			
D10		INC. 100-133			*			
099-1	5196043000	CARBURETOR	S	1	*			
D10		INC. 100-133			*			
099-2	168682-5	CARBURETOR	O	1				
D10		INC. 100-133						
100	5196019240	ADJUST SCREW		1	*			
100-1	5196043010	STAY	X	1	*			
100-2	346510-6	STAY	O	1				
101	5196019310	SCREW		2	*			
101-1	5196043020	SCREW	X	2	*			
101-2	266720-8	TAPPING SCREW M3X10	O	2				
102	5196019450	LEVER END		1	*			
102-1	326099-0	END LEVER	O	1				
103	5196019460	WASHER		1	*			
103-1	267837-0	WASHER	O	1				
104	5196036010	STARTER LEVER		1	*			
104-1	452976-1	STARTER LEVER	O	1				
105	5196036020	STARTER SPRING		1	*			
105-1	234221-4	STARTER SPRING	O	1				
106	5196019250	SLOW STOP SCREW		1	*			
106-1	266718-5	TAPPING SCREW M3X16	O	1				
107	5196019510	E-RING		1	*			
107-1	259051-2	E-RING 4.5	O	1				
108	5196019220	O-RING		1	*			
108-1	213630-0	O-RING 18	O	1				
109	5196019150	O-RING		1	*			
109-1	213629-5	O-RING 2	O	1				
110	5196032010	MAIN JET		1	*			
110-1	326100-1	MAIN JET	O	1				
111	5196019410	O-RING		1	*			
111-1	213631-8	O-RING 4	O	1				

Please order the parts with part number.

Print Date 4/7/2019

Model No.RBC2110 STRING TRIMMER

Item	Parts No.	Description	I/C	Qty	New/Old	Opt. 1	Opt. 2	Note
112	5196019360	CHECK VALVE ASSY		1	*			
112-1	126052-4	CHECK VALVE ASSEMBLY	O	1				
113	5196019420	GUIDE PLATE		1	*			
113-1	346509-1	GUIDE PLATE	O	1				
114	5196019430	SCREW		1	*			
114-1	266721-6	TAPPING SCREW M2.6X6	O	1				
115	5196019040	DIAPHRAGM ASSY		1	*			
115-1	126038-8	DIAPHRAGM ASSEMBLY	O	1				
116	5196019050	DIAPHRAGM COVER		1	*			
116-1	346513-0	DIAPHRAGM COVER	O	1				
117	5196019060	SCREW		2	*			
117-1	266715-1	TAPPING SCREW M3X8	O	2				
118	5196019110	PUMP PACKING		1	*			
118-1	442176-1	PUMP PACKING	O	1				
119	5196019120	PUMP DIAPHRAGM		1	*			
119-1	424460-6	PUMP DIAPHRAGM	O	1				
120	5196019350	PUMP PLATE		1	*			
120-1	346508-3	PUMP PLATE	O	1				
121	5196019330	FILTER		1	*			
121-1	352018-0	FILTER	O	1				
122	5196019130	PUMP PACKING		1	*			
122-1	442178-7	PUMP PACKING	O	1				
123	5196019340	PUMP COVER		1	*			
123-1	452975-3	PUMP COVER	O	1				
124	5246009030	COMBINATION VALVE		1	*			
124-1	452977-9	COMBINATION VALVE	O	1				
125	5246009040	PRIMING PUMP		1	*			
125-1	424462-2	PRIMING PUMP	O	1	*			
125-2	424462-2	PRIMING PUMP	O	1				
126	5196019320	PRIMING PUMP PLATE		1	*			
126-1	346507-5	PRIMING PUMP PLATE	O	1	*			
126-2	346507-5	PRIMING PUMP PLATE	O	1				
127	5196019140	SCREW		4	*			
127-1	266716-9	TAPPING SCREW M3X18	O	4				
128	5193017040	O-RING		1	*			
128-1	213632-6	O-RING 14.8	O	1				
129	5193018010	PLATE,AIR CLEANER ASSY		1	*			
129-1	126036-2	AIR CLEANER PLATE ASSEMBLY	O	1				
130	0043105600	PAN HEAD SCREW M5X60		2	*			
130-1	266695-1	PAN HEAD SCREW M5X60	O	2				
131	5193017030	ELEMENT,AIR CLEANER		1	*			

Please order the parts with part number.

Print Date 4/7/2019

Model No.RBC2110 STRING TRIMMER

Item	Parts No.	Description	I/C	Qty	New/Old	Opt. 1	Opt. 2	Note
131-1	443168-3	AIR CLEANER PLATE ELEMENT	O	1				
132	5193018020	CASE,AIR CLEANER		1	*			
132-1	452971-1	AIR CLEANER CASE	O	1				
133	0140059480	SCREW ASS'Y M5X14		1	*			
133-1	266809-2	P.H.SCREW M5X14 WITH WR	O	1				
134	5195009000	REWIND STARTER		1	*			
D10		INC. 62-66,68,70,71			*			
134-1	126037-0	RECOIL STARTER ASSEMBLY	O	1				
D10		INC. 62-66,68,70,71						
135	808723-2	CAUTION LABEL		1				
136	413143-3	WASHER		2				

Please order the parts with part number.

Print Date 4/7/2019