

Model No.PM5120 PETROL LAWN MOWER

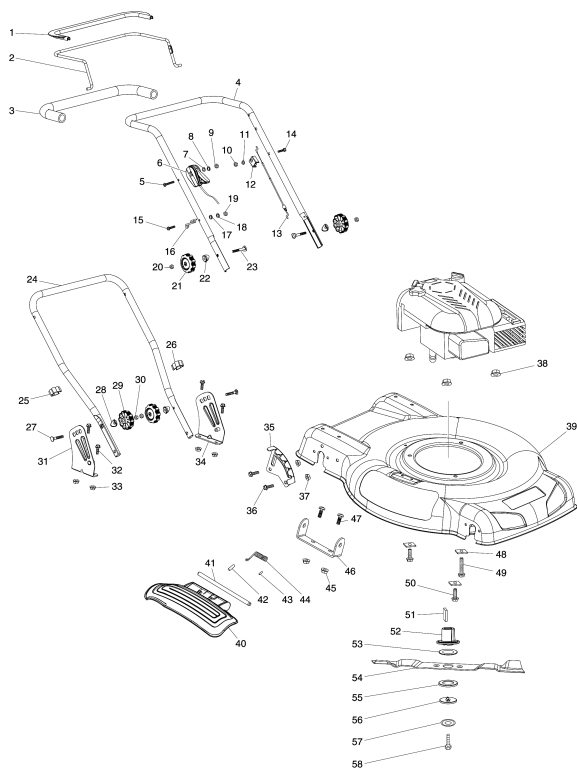

<https://msi.makita.co.jp/MSiWW/MSiWW/swf/print.html>

1/7

Model No.PM5120 PETROL LAWN MOWER

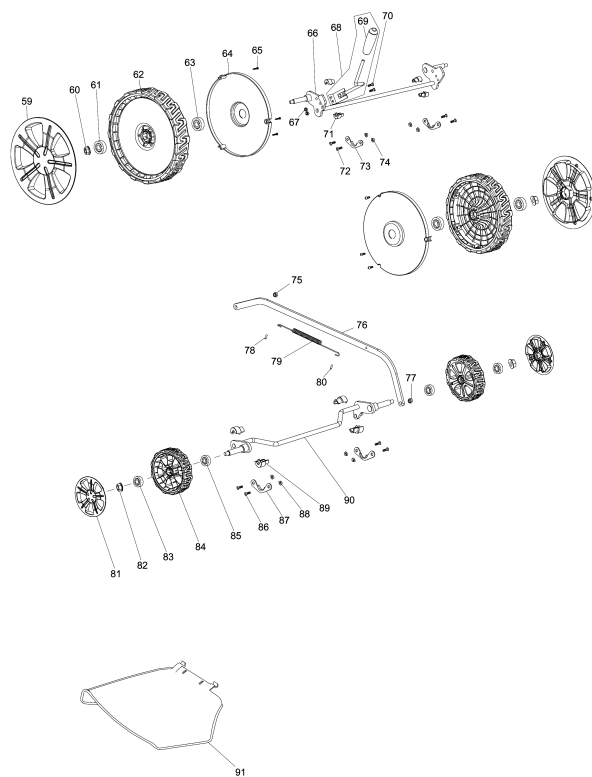

<https://msi.makita.co.jp/MSiWW/MSiWW/swf/print.html>

3/7

Model No.PM5120 PETROL LAWN MOWER

Item	Parts No.	Description	I/C	Qty	New/Old	Opt. 1	Opt. 2	Note
001	671687001	LEVER SHEATH		1				
002	671001816	MOTOR BRAKE LEVER		1				
003	671101901	HANDLE SHEATH		1				
004	671001836	UPPER HANDLE BAR		1				
005	671006059	HEX.FRANGE BOLT M6X55		1	*			
005-1	671006082	HEX. FLANGE BOLT M6X50	O	1				
006	671010620	THROTTLE CONTROL BOX ASSY		1				
007	DA00000574	FLAT WASHER 6		1				
008	671008003	SPRING WASHER 6		1	*			
008-1	DA00000576	SPRING WASHER 6	O	1				
009	671005016	HEX.CAP MUT M6		1	*			
009-1	DA00000575	HEX.CAP NUT M6	O	1				
010	671005016	HEX.CAP MUT M6		1	*			
010-1	DA00000575	HEX.CAP NUT M6	O	1				
011	DA00000574	FLAT WASHER 6		1				
012	DA00000573	OUTER WIRE STOPPER		1				
013	671012160	CONTROL CABLE (MOTOR BRAKE)		1				
014	DA00000577	HEX.FLANGE BOLT M6X35		1				
015	DA00000577	HEX.FLANGE BOLT M6X35		1				
016	DA00000579	STARTER GRIP HOOK		1				
017	DA00000574	FLAT WASHER 6		1				
018	671008003	SPRING WASHER 6		1	*			
018-1	DA00000576	SPRING WASHER 6	O	1				
019	671005016	HEX.CAP MUT M6		1	*			
019-1	DA00000575	HEX.CAP NUT M6	O	1				
020	671005007	HEX.NUT M8		2				
021	671453001	KNOB		2				
022	671001085	PLASTIC SADDLE WASHER 8		2				
023	671006004	SADDLE HEAD BOLT M8X58		2				
024	671001815	LOWER HANDLE BAR		1				
025	671177001	CABLE CLIP		1	*			
025-1	671611001	CABLE CLIP	O	1				
026	671177001	CABLE CLIP		1	*			
026-1	671611001	CABLE CLIP	O	1				
027	DA00000566	BOLT M8X40		2				
028	671001085	PLASTIC SADDLE WASHER 8		2				
029	671453001	KNOB		2				
030	671005007	HEX.NUT M8		2				
031	DA00000590	RIGHT HANDLE BRACKET RED		1				
032	DA00000562	HEX.FLANGE BOLT M8X16		4				
033	DA00000537	HEX.FLANGE LOCK NUT M8		4				

Please order the parts with part number.

Print Date 30/9/2020

<https://msi.makita.co.jp/MSiWW/MSiWW/swf/print.html>

5/7

Model No.PM5120 PETROL LAWN MOWER

Item	Parts No.	Description	I/C	Qty	New/Old	Opt. 1	Opt. 2	Note
034	DA00000589	LEFT HANDLE BRACKET RED		1				
035	671001710	HEIGHT ADJUSTER STOP PLATE		1				
036	DA00000562	HEX.FLANGE BOLT M8X16		2				
037	DA00000537	HEX.FLANGE LOCK NUT M8		2				
038	DA00000537	HEX.FLANGE LOCK NUT M8		3				
039	671001601	DECK RED		1				
040	DA00000559	SIDE DISCHARGE FLAP COVER		1				
041	DA00000558	SIDE DISCHARGE FLAP HINGE ROD		1				
042	671003003	HEAT SHRINK TUBE 6		1				
043	671300101	HEAT SHRINK TUBE 3		1				
044	DA00000556	SIDE FLAP TORSION SPRING		1				
045	DA00000543	HEX.FLANGE LOCK NUT M6		2				
046	DA00000555	SIDE FLAP HINGE PLATE		1				
047	DA00000552	TRUSS HEAD SCREW M6X16		2				
048	671002106	RECTANGLE WASHER 8		3				
049	671006079	HEX. BOLT M8X60		1				
050	DA00000586	HEX. BOLT M8X35		2				
051	671090018	FLAT KEY		1				
052	671002051	INNER FRANGE		1				
053	DA00000533	NYLON FLAT WASHER 32		1				
054	DA00000944	BLADE 51		1				
055	DA00000531	NYLON CUP WASHER 32		1				
056	DA00000530	OUTER FRANGE		1				
057	DA00000529	DISH SPRING WASHER 10		1				
058	671006141	BLADE TIGHTEN BOLT 3/8-24 UNF		1				
059	671001322	WHEEL COVER 10 INCH		2				
060	DA00000537	HEX.FLANGE LOCK NUT M8		2				
061	DA00000538	BALL BEARING 6201ZZ		2				
062	671002021	WHEEL ASSY 11 INCH		2				
063	DA00000538	BALL BEARING 6201ZZ		2				
064	671666001	INSIDE WHEEL COVER 10 INCH		2				
065	DA00000603	TAPPING SCREW ST4X16		6				
066	671001828	REAR AXLE		1				
067	DA00000549	NYLON INSERT HEX.LOCK NUT M6		2				
068	671010450	HEIGHT ADJUSTMENT LEVER ASSY		1	*			
D10		INC. 69			*			
068-1	DA00001075	HEIGHT ADJUSTMENT LEVER ASSY	O	1				
D10		INC. 69						
069	DA00001058	HEIGHT ADJUSTMENT KNOB		1				

Please order the parts with part number.

Print Date 30/9/2020

<https://msi.makita.co.jp/MSiWW/MSiWW/swf/print.html>

6/7

Model No.PM5120 PETROL LAWN MOWER

Item	Parts No.	Description	I/C	Qty	New/Old	Opt. 1	Opt. 2	Note
070	671002030	PAN. HEAD SCREW M6X14		2				
071	DA00000545	AXLE MOUNT		4				
072	671002019	TRUSS HEAD SCREW M6X12		4				
073	DA00000542	BEARING CASE RETAINER		2				
074	DA00000543	HEX.FLANGE LOCK NUT M6		4				
075	DA00000549	NYLON INSERT HEX.LOCK NUT M6		1				
076	671001827	LINK ROD		1				
077	DA00000549	NYLON INSERT HEX.LOCK NUT M6		1				
078	671300101	HEAT SHRINK TUBE 3		1				
079	671011039	HEIGHT ADJUST TENSION SPRING		1				
080	671300101	HEAT SHRINK TUBE 3		1				
081	DA00000536	WHEEL COVER 7 INCH		2				
082	DA00000537	HEX.FLANGE LOCK NUT M8		2				
083	DA00000538	BALL BEARING 6201ZZ		2				
084	671020160	WHEEL ASSY 8 INCH		2				
085	DA00000538	BALL BEARING 6201ZZ		2				
086	671002019	TRUSS HEAD SCREW M6X12		4				
087	DA00000542	BEARING CASE RETAINER		2				
088	DA00000543	HEX.FLANGE LOCK NUT M6		4				
089	DA00000545	AXLE MOUNT		4				
090	671001811	FRONT AXLE		1				
091	671546001	SIDE DISCHARGE OUTLET		1				
A01	671001078	BOX WRENCH 21MM		1				
A02	DA00000584	WRENCH HANDLE		1				

Please order the parts with part number.

Print Date 30/9/2020