



Spare Parts List
Ersatzteilliste
Liste de pièces détachées
Lista de piezas de repuesto

2013-11

PLM4626
PLM4627
PLM4628

PLM4626, 4627, 4628 (D, GB, F, E)

PLM4626, PLM4627,
PLM4628

1

PM-46 B, PLM4626
PM-46 B, PLM4626
PM-46 B, PLM4626
PM-46 B, PLM4626

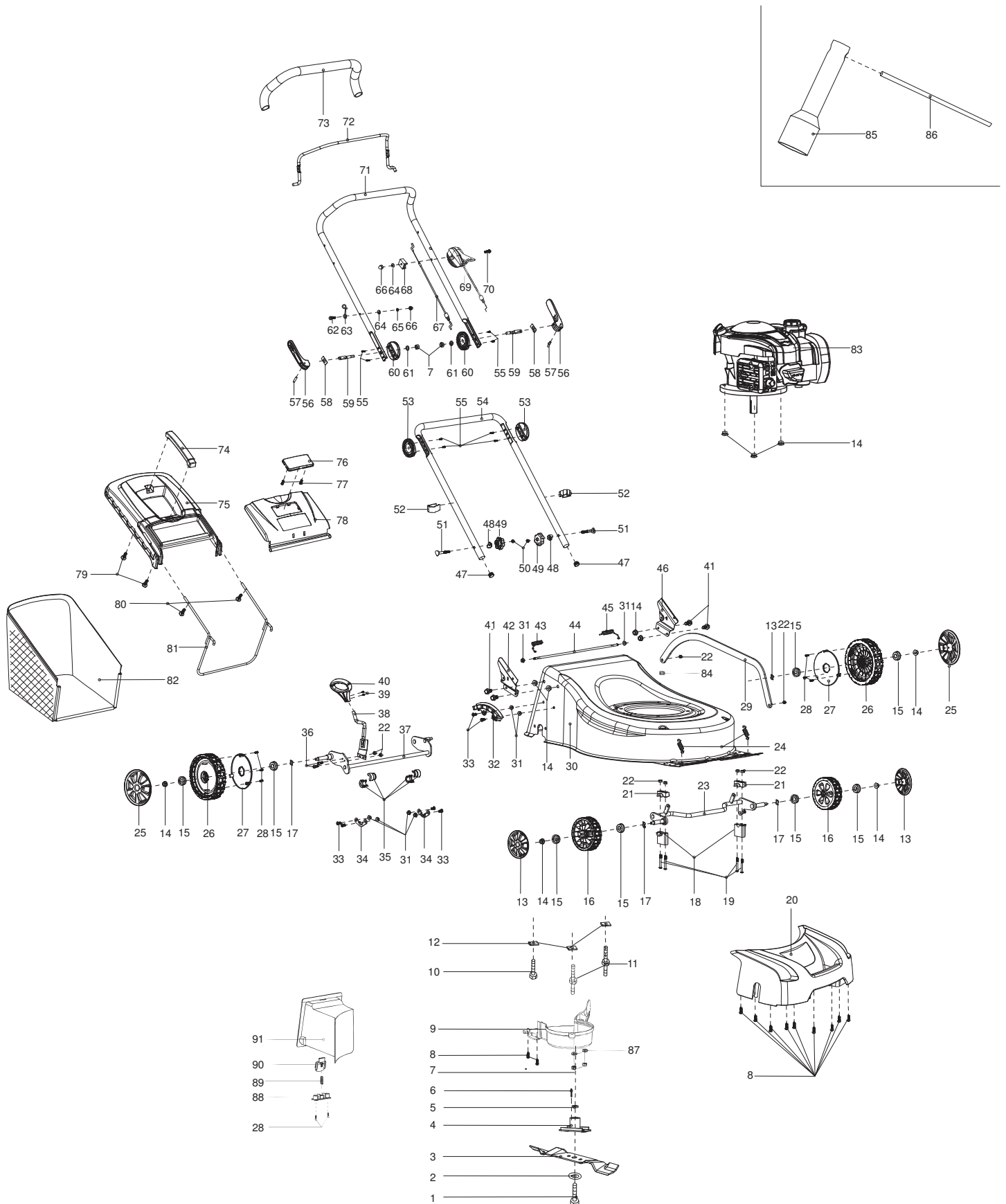

PLM4626, PLM4627,
PLM4628

1

PM-46 B, PLM4626
PM-46 B, PLM4626
PM-46 B, PLM4626
PM-46 B, PLM4626



Seite / Page	Pos.	PLM4626	Teil-Nr. Part No. No. de pièce No. de pieza	Hinweise Notes Renseign. Nota	Bezeichnung	Spezifikation Specification	Description	Désignation	Denominación
1	1	1	671 006 062		MESSERSCHRAUBE	3/8", L=40mm	BLADE TIGHTEN SCREW	VIS DE LAME	TORNILLO DE LA CUCHILLA
1	2	1	671 010 730		SCHEIBE	Φ44.5/10.2x2.5	LID SHAPE WASHER	RONDELLE	ARANDELA
1	3	1	671 014 610		MESSER	460X55X4mm	BLADE	LAME	CUCHILLA
1	4	1	671 002 448		MESSERHALTER		BLADE SUPPORT	MOYEU	SOPORTE DE LA CUCHILLA
1	5	1	671 002 093		BUCHSE	Φ22.2xΦ10.5x7m m	BLADE SUPPORT BUSH	DOUILLE	CASQUILLO
1	6	1	671 090 077		PASSFEDER	4.7x4x4.7	FLAT KEY	CLAVETTE	CHAVETA
1	7	4	671 005 008		6KT-MUTTER	M8	HEXAGONAL LOCKING NUT	ECROU HEXAGONAL	TUERCA HEXAGONAL
1	8	11	671 001 037		SCHRAUBE SELBSTSCHNEIDEN D	5x16	SELF-TAPPING SCREW	VIS DE FORAGE	TORNILLO PERFORADOR
1	9	1	671 558 001		RIEMENABDECKUNG		BELT PROTECTION COVER	COUVERCLE DE COURROIE	CUBIERTA DE CORREA
1	10	1	671 006 025		6KT-SCHRAUBE	M8x35	HEXAGON BOLT	VIS À SIX PANS	TORNILLO HEXAGONAL
1	11	2	671 003 044		SPEZIALSCHRAUBE	M8x17x35	SPECIAL SCREW	VIS SPÉCIALE	TORNILLO ESPECIAL
1	12	3	671 002 106		4KT-SCHEIBE	φ10	SQUARE GASKET	RONDELLE	ARANDELA
1	13	2	671 105 103		RADKAPPE	8"	WHEEL COVER	CHAPEAU DE MOYEU	CAPERUZA DE RUEDA
1	14	11	671 005 028		6KT-MUTTER	M8	HEXAGONAL LOCKING NUT	ECROU HEXAGONAL	TUERCA HEXAGONAL
1	15	8	671 040 160		LAGER		BEARING	ROULEMENT	RODAMIENTO
1	16	2	671 204 301		RAD KPL.	8"	WHEEL ASS'Y	ROUE CPL.	RUEDA CPL.
1	17	4	671 007 062		WELLENSCHEIBE	φ12xφ18x0.5	WAVE WASHER	RONDELLE	ARANDELA
1	18	2	671 376 001		LAGERSCHALE		LOWER SUPPORT OF WHEEL AXIS	COQUILLE DE COUSSINET	MITAD DE RODAMIENTO
1	19	4	671 006 119		SCHRAUBE	M6x60	BOLT	VIS	TORNILLO
1	20	1	671 536 001		FRONTTEIL	18"	FRONT COVER	PANNEAU	FRONTAL CUBIERTA
1	21	2	671 376 002		LAGERSCHALE		UPPER SUPPORT OF WHEEL AXIS	COQUILLE DE COUSSINET	MITAD DE RODAMIENTO
1	22	8	671 005 005		6KT-MUTTER	M6	LOCKING NUT	ECROU	TUERCA
1	23	1	671 001 374		VORDERACHSE	18"	FRONT WHEEL AXLE	ESSIEU AVANT	EJE DELANTERO
1	24	2	671 011 112		ZUGFEDER		EXTENSION SPRING OF FRONT WHEEL AXLE	RESSORT	RESORTE
1	25	2	671 010 530		RADKAPPE	11"	WHEEL COVER	CHAPEAU DE MOYEU	CAPERUZA DE RUEDA
1	26	2	671 020 440		RAD KPL.		WHEEL ASS'Y	ROUE CPL.	RUEDA CPL.
1	27	2	671 334 001		STAUBSCHUTZABDE CKUNG	11"	DUST COVER	COUVERCLE	CUBIERTA
1	28	6	671 107 301		SCHRAUBE SELBSTSCHNEIDEN D	ST4x16	SELF-TAPPING SCREW	VIS DE FORAGE	TORNILLO PERFORADOR
1	29	1	671 001 377		VERBINDUNGSSTAN GE	18"	LINK ROD	BARRE DE RACCORDEMENT	BARRA DE CONEXIÓN
1	30	1	671 017 460		DECK	18", MAKITA	DECK	CAPOT	CAPOTA
1	31	8	671 005 024		6KT-MUTTER	M6	HEXAGONAL LOCKING NUT	ECROU HEXAGONAL	TUERCA HEXAGONAL
1	32	1	671 001 025		DREHPUNKT FÜR HÖHENVERSTELLUN G	18"	HEIGHT ADJUSTMENT PLATE	POINT DE ROTATION POUR LE RÉGLAGE EN HAUTEUR	PUNTO DE GIRO PARA REGLAJE DE ALTURA
1	33	6	671 002 019		SCHRAUBE	M6x12	TRIGGER BOLT	VIS	TORNILLO
1	34	2	671 001 244		FIXIERUNG		RING OF AXLE FIXING	FIXATION	FIJACIÓN
1	35	4	671 353 001		LAGERSCHALE		AXLE SHEATH	PLAQUETTE	COJINETE
1	36	2	671 002 030		SCHRAUBE	M6x14	TRIGGER BOLT	VIS	TORNILLO
1	37	1	671 001 410		HINTERRADACHSE	18"	REAR WHEEL AXLE	AXE ROUE ARRIERES	EJE RUEDAS TRASERAS
1	38	1	671 001 411		HEBEL, HÖHENVERSTELLUN G	18"	HANDLE ASS'Y	LEVIER, REGLAGE HAUTEUR	PALANCA, AJUSTE ALTURA

PLM4626, PLM4627,
PLM4628

1

PM-46 B, PLM4626
PM-46 B, PLM4626
PM-46 B, PLM4626
PM-46 B, PLM4626

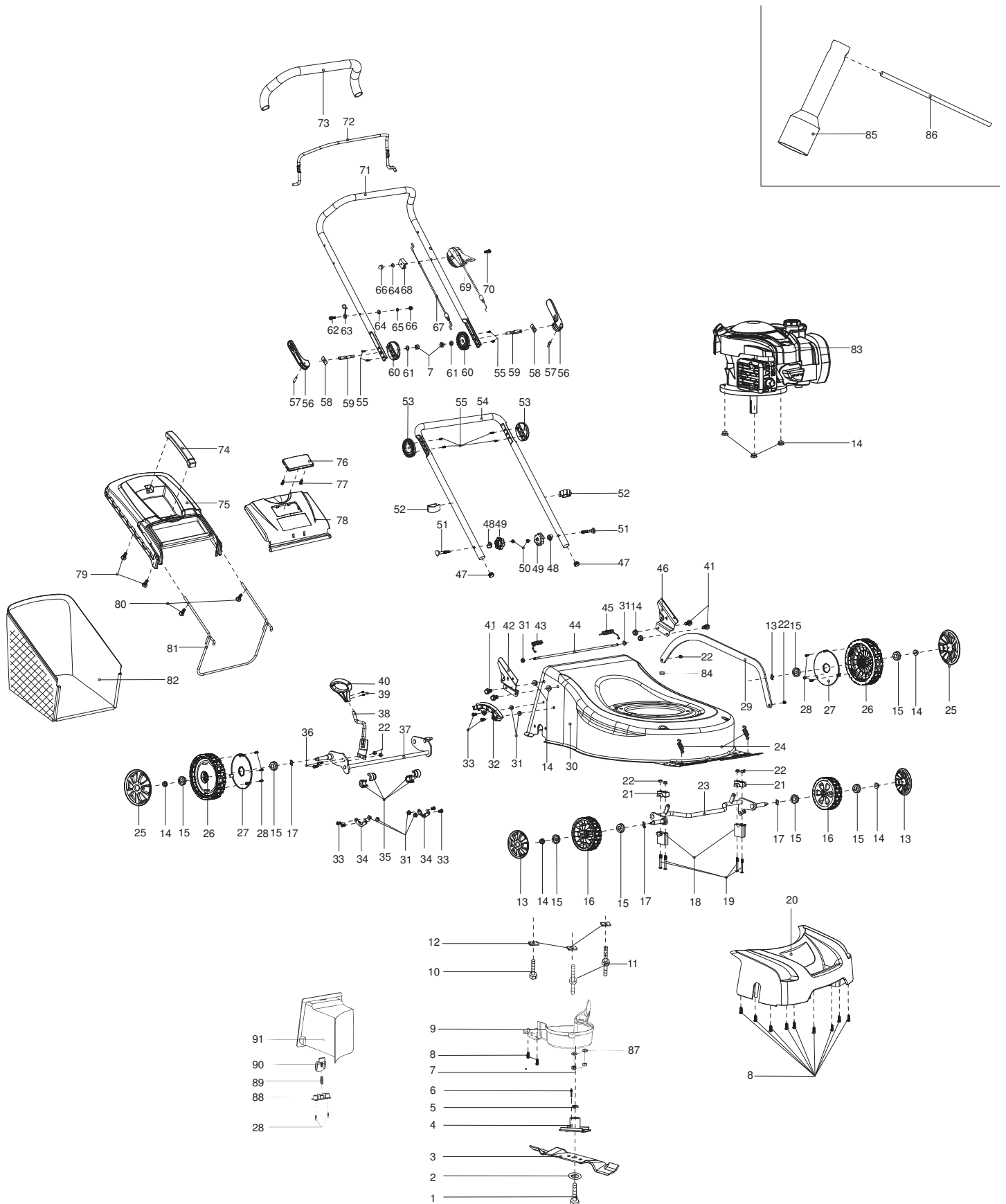

PLM4626, PLM4627,
PLM4628

1

PM-46 B, PLM4626
PM-46 B, PLM4626
PM-46 B, PLM4626
PM-46 B, PLM4626



Seite / Page	Pos.	PLM4626	Teil-Nr. Part No. No. de pièce No. de pieza	Hinweise Notes Renseign. Nota	Bezeichnung	Spezifikation Specification	Description	Désignation	Denominación
1	39	2	671 003 033		SCHRAUBE	M5x8	SCREW	VIS	TORNILLO
1	40	1	671 010 590		GRIFF		GRIP	POIGNÉE	MANGO
1	41	4	671 006 064		6KT-SCHRAUBE	M8x6	HEXAGON HEAD BOLT	VIS À SIX PANS	TORNILLO HEXAGONAL
1	42	1	671 001 751		GRIFFANBINDUNG, RECHTS	18", MAKITA	BRACKET HANDLE, RIGHT	BRIDE DE POIGNÉE, DROITE	FIJACIÓN DE MANGO, DERECHA
1	43	1	671 011 113		DREHFEDER RECHTS		TORSION SPRING, RIGHT	RESSORT DE TENSION À DROITE	RESORTE DE TORSIÓN DERECHO
1	44	1	671 001 366		STANGE GRASKLAPPE	φ6,18"	LONG POLE	TRINGLE TRAPPE À HERBE	BARRA TAPA DE YERBA
1	45	1	671 011 114		DREHFEDER LINKS		TORSION SPRING, LEFT	RESSORT DE TENSION À GAUCHE	RESORTE DE TORSIÓN IZQUIERDO
1	46	1	671 001 750		GRIFFANBINDUNG, LINKS	18", MAKITA	BRACKET HANDLE, LEFT	BRIDE DE POIGNÉE, GAUCHE	FIJACIÓN DE MANGO, IZQ.
1	47	2	671 001 199		ROHRSTOPFEN	φ22mm	TUBE PLUG	BOUCHON DE TUBE	TAPÓN DE TUBO
1	48	2	671 001 085		SCHEIBE		WASHER	RONDELLE	ARANDELA
1	49	2	671 365 005		STERNGRIFFMUTTE R		STAR KNOB	MANETTE	MANIJA DE ESTRELLA
1	50	2	671 005 023		6KT-MUTTER	M8	HEXAGONAL NUT	ECROU HEXAGONAL	TUERCA HEXAGONAL
1	51	2	671 006 004		FLACHKOPFSCHRAU BE	M8x52	FLAT HEAD BOLT	VIS À TÊTE CYLINDRIQUE	TORNILLO DE CABEZA PLANA
1	52	2	671 611 001		BOWDENZUGHALTE R		BOWDEN CABLE CLAMP	COLLIER DE SERRANGE	SOPORTE DE CABLE BOWDEN
1	53	2	671 055 001		EINSTELLRING, UNTEN		LOWER ADJUSTING TOOTH RING	ANNEAU DE RÉGLAGE, INF.	ANILLO DE FLUJO, INF.
1	54	1	671 001 804		UNTERHOLM		LOWER HANDLE	MANCHE INFÉRIEURE	MANGO INFERIOR
1	55	8	671 001 049		SCHRAUBE	3x10	BOLT	VIS	TORNILLO
1	56	2	671 364 005		VERSTELLGRIFF		LOCKING HANDLE	POIGNÉE DE RÉGLAGE	AGARRE AJUSTABLE
1	57	2	671 090 048		ZYLINDERSTIFT	5x20	CYLINDRICAL PIN	GOUILLE CYLINDRIQUE	PASADOR CILINDRICO
1	58	2	671 001 119		DRUCKPLATTE		PRESSING PLATE	PLAQUE	PLACA
1	59	2	671 001 301		SCHRAUBE	M8x69	BOLT	VIS	TORNILLO
1	60	2	671 054 001		EINSTELLRING, OBEN		UPPER ADJUSTING TOOTH RING	ANNEAU DE RÉGLAGE, SUP.	ANILLO DE FLUJO, SUP.
1	61	2	671 011 890		FLACHSCHEIBE	φ16xφ8x0,8	FLAT WASHER	RONDELLE PLATE	ARANDELA
1	62	1	671 006 077		SCHRAUBE	M6x35	BOLT	VIS	TORNILLO
1	63	1	671 001 647		HAKEN		CABLE HOOK	TENON	GANCHO
1	64	3	671 007 008		SCHEIBE	φ16xφ8x0,8	WASHER	RONDELLE	ARANDELA
1	65	1	671 008 003		FEDERSCHEIBE	φ6,65	SPRING WASHER	RONDELLE A RESSORT	ARANDELA ELASTICO
1	66	2	671 050 160		6KT-MUTTER	M6	HEXAGONAL LOCKING NUT	ECROU HEXAGONAL	TUERCA HEXAGONAL
1	67	1	671 001 258		BOWDENZUG (MOTORBREMSE)	960mm	CONTROL CABLE (MOTOR BRAKE)	CÂBLE BOWDEN (FREIN MOTEUR)	TRACCIÓN BOWDEN (FRENO MOTOR)
1	68	1	671 336 001		HALTERUNG		FIXED BRACKET	FIXATION	SOPORTE
1	69	1	671 013 260		MOTORFERNBEDIEN UNG INKL. BOWDENZUG		THROTTLE HANDLE ASS'Y	LEVIER / CABLE, ACCELERATEUR	PALANCA / CABLE, ACELERADOR
1	70	1	671 006 119		SCHRAUBE	M6x60	BOLT	VIS	TORNILLO
1	71	1	671 017 970		OBERHOLM		UPPER HANDLE	MANCHE SUPÉRIEURE	MANGO SUPERIOR
1	72	1	671 017 580		HEBEL, MOTORBREMSE		LEVER, MOTOR BRAKE	LEVIER FREIN MOTEUR	PALANCA, FRENO MOTOR
1	73	1	671 001 029		GRIFFUMHÜLLUNG		HANDLE SHEATH	POIGNÉE	EMPUÑADURA
1	74	1	671 384 001		HANDGRIFF		GRASS CATCHER HANDLE	POIGNÉE	MANGO
1	75	1	671 382 001		KORB, OBERTEIL	60L	GRASS-BOX, UPPER	SAC, PARTIE	CESTO, SUPERIOR
1	76	1	671 385 001		SICHTFENSTER		TRANSPARENT WINDOW	REGARD	VENTANILLA

PLM4626, PLM4627,
PLM4628

1

PM-46 B, PLM4626
PM-46 B, PLM4626
PM-46 B, PLM4626
PM-46 B, PLM4626

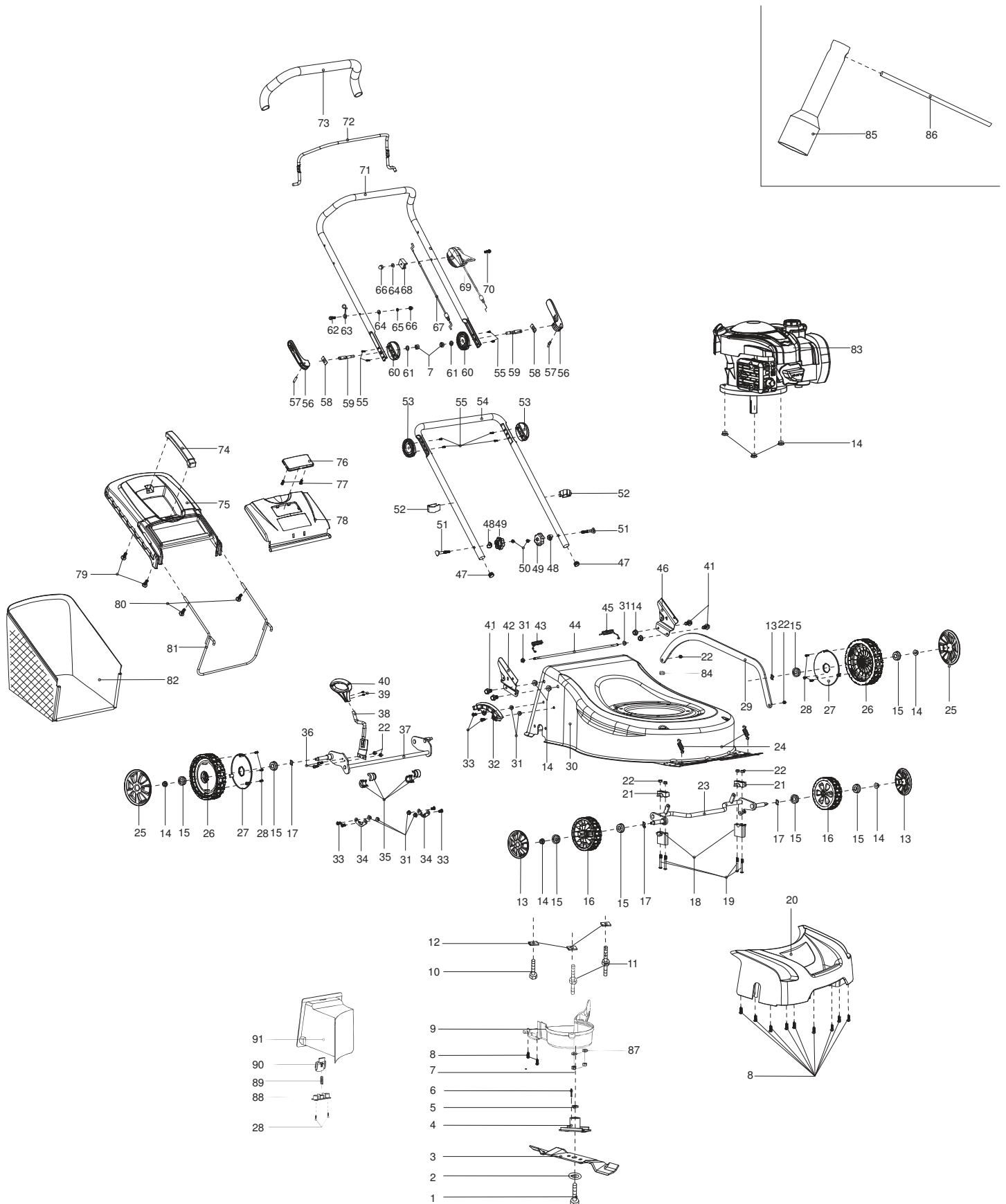

PLM4626, PLM4627,
PLM4628

1

PM-46 B, PLM4626
PM-46 B, PLM4626
PM-46 B, PLM4626
PM-46 B, PLM4626



Seite / Page	Pos.	PLM4626	Teil-Nr. Part No. No. de pièce No. de pieza	Hinweise Notes Renseign. Nota	Bezeichnung	Spezifikation Specification	Description	Désignation	Denominación
1	77	2	671 010 710		SCHRAUBE SELBSTSCHNEIDEN D	ST4x12	SELF-TAPPING SCREW	VIS DE FORAGE	TORNILLO PERFORADOR
1	78	1	671 004 272		HECKKLAPPE KPL.		REAR FLAP ASS'Y	HAYON CPL.	PORTÓN TRASERO CPL.
1	79	2	671 001 046		SCHRAUBE SELBSTSCHNEIDEN D	8x19	SELF-TAPPING SCREW	VIS DE FORAGE	TORNILLO PERFORADOR
1	80	2	671 001 032		SCHRAUBE	4,2x18	BOLT	VIS	TORNILLO
1	81	1	671 001 381		RAHMEN	18"/20"	GRASS CATCHER BRACKET	CADRE	MARKO
1	82	1	671 013 783		GRASFANGKORB	60L, MAKITA LOGO	GRASS CATCHER	SAC	GESTO
1	83	1			MOTOR	500/140CC/2.2KW /2850rpm, B&S, XAQ, MAKITA	ENGINE	MOTEUR	MOTOR
1	84	1	671 800 104		GUMMITÜLLE		CORD PROTECTING SHEATH	PASSE-FIL	BOQUILLA DE CAUCHO
1	85	1	671 001 612		STECKSCHLÜSSEL	16mm	BOX SPANNER	CLÉ À DOUILLE	LLAVE
1	86	1	671 001 079		SPANNSTANGE	Φ8x110mm	SPANNER POLE	TIRANT	SENSOR
1	87	2	671 007 007		SCHEIBE	φ8	WASHER	RONDELLE	ARANDELA
1	88	1	671 317 001		DRUCKPLATTE		PRESSING PLATE	PLAQUE	PLACA
1	89	1	671 011 005		FEDER	φ8,0xφ0,9x31mm	SPRING	RESSORT	MUELLE
1	90	1	671 316 004		VERRIEGELUNGSKN OPF	20"	LOCKING BUTTON	TÊTE DE VERROUILLAGE	BOTÓN DE BLOQUEO
1	91	1	671 326 001		MULCHKEIL		MULCHING KIT	KIT MULCH	KIT DE MANTILLO

Seite / Page	Pos.	PLM4627	Teil-Nr. Part No. No. de pièce No. de pieza	Hinweise Notes Renseign. Nota	Bezeichnung	Spezifikation Specification	Description	Désignation	Denominación
2	1	1	671 006 062		MESSERSCHRAUBE	3/8", L=40mm	BLADE TIGHTEN SCREW	VIS DE LAME	TORNILLO DE LA CUCHILLA
2	2	1	671 010 730		SCHEIBE	Φ44.5/10.2x2.5	LID SHAPE WASHER	RONDELLE	ARANDELA
2	3	1	671 014 610		MESSER	460X55X4mm	BLADE	LAME	CUCHILLA
2	4	1	671 002 448		MESSERHALTER		BLADE SUPPORT	MOYEU	SOPORTE DE LA CUCHILLA
2	5	1	671 002 093		BUCHSE	Φ22.2xΦ10.5x7mm	BLADE SUPPORT BUSH	DOUILLE	CASQUILLO
2	6	1	671 090 077		PASSFEDER	4.7x4x4.7	FLAT KEY	CLAVETTE	CHAVETA
2	7	4	671 005 008		6KT-MUTTER	M8	HEXAGONAL LOCKING NUT	ECROU HEXAGONAL	TUERCA HEXAGONAL
2	8	11	671 001 037		SCHRAUBE SELBSTSCHNEIDEN D	5x16	SELF-TAPPING SCREW	VIS DE FORAGE	TORNILLO PERFORADOR
2	9	1	671 580 010		RIEMENABDECKUNG		BELT PROTECTION COVER	COUVERCLE DE COURROIE	CUBIERTA DE CORREA
2	10	1	671 006 025		6KT-SCHRAUBE	M8x35	HEXAGON BOLT	VIS À SIX PANS	TORNILLO HEXAGONAL
2	11	2	671 003 044		SPEZIALSCHRAUBE	M8x17x35	SPECIAL SCREW	VIS SPÉCIALE	TORNILLO ESPECIAL
2	12	3	671 002 106		4KT-SCHEIBE	φ10	SQUARE GASKET	RONDELLE	ARANDELA
2	13	2	671 105 103		RADKAPPE	8"	WHEEL COVER	CHAPEAU DE MOYEU	CAPERUZA DE RUEDA
2	14	11	671 005 028		6KT-MUTTER	M8	HEXAGONAL LOCKING NUT	ECROU HEXAGONAL	TUERCA HEXAGONAL
2	15	8	671 040 160		LAGER		BEARING	ROULEMENT	RODAMIENTO
2	16	2	671 204 301		RAD KPL.	8"	WHEEL ASS'Y	ROUE CPL.	RUEDA CPL.
2	17	4	671 007 062		WELLENSCHEIBE	φ12xφ18x0.5	WAVE WASHER	RONDELLE	ARANDELA
2	18	2	671 376 001		LAGERSCHALE		LOWER SUPPORT OF WHEEL AXIS	COQUILLE DE COUSSINET	MITAD DE RODAMIENTO
2	19	4	671 006 119		SCHRAUBE	M6x60	BOLT	VIS	TORNILLO
2	20	1	671 536 001		FRONTTEIL	18"	FRONT COVER	PANNEAU	FRONTAL CUBIERTA
2	21	2	671 376 002		LAGERSCHALE		UPPER SUPPORT OF WHEEL AXIS	COQUILLE DE COUSSINET	MITAD DE RODAMIENTO
2	22	8	671 005 005		6KT-MUTTER	M6	LOCKING NUT	ECROU	TUERCA
2	23	1	671 001 374		VORDERACHSE	18"	FRONT WHEEL AXLE	ESSIEU AVANT	EJE DELANTERO
2	24	2	671 011 112		ZUGFEDER		EXTENSION SPRING OF FRONT WHEEL AXLE	RESSORT	RESORTE
2	25	2	671 010 530		RADKAPPE	11"	WHEEL COVER	CHAPEAU DE MOYEU	CAPERUZA DE RUEDA
2	26	2	671 020 440		RAD KPL.		WHEEL ASS'Y	ROUE CPL.	RUEDA CPL.
2	27	2	671 334 001		STAUBSCHUTZABDECKUNG	11"	DUST COVER	COUVERCLE	CUBIERTA
2	28	6	671 107 301		SCHRAUBE SELBSTSCHNEIDEN D	ST4x16	SELF-TAPPING SCREW	VIS DE FORAGE	TORNILLO PERFORADOR
2	29	1	671 001 377		VERBINDUNGSSTANGE	18"	LINK ROD	BARRE DE RACCORDEMENT	BARRA DE CONEXIÓN
2	30	1	671 001 748		DECK	18", MAKITA	DECK	CAPOT	CAPOTA
2	31	8	671 005 024		6KT-MUTTER	M6	HEXAGONAL LOCKING NUT	ECROU HEXAGONAL	TUERCA HEXAGONAL
2	32	1	671 001 025		DREHPUNKT FÜR HÖHENVERSTELLUNG	18"	HEIGHT ADJUSTMENT PLATE	POINT DE ROTATION POUR LE RÉGLAGE EN HAUTEUR	PUNTO DE GIRO PARA REGLAJE DE ALTURA
2	33	6	671 002 019		SCHRAUBE	M6x12	TRIGGER BOLT	VIS	TORNILLO
2	34	2	671 001 244		FIXIERUNG		RING OF AXLE FIXING	FIXATION	FIJACIÓN
2	35	4	671 353 001		LAGERSCHALE		AXLE SHEATH	PLAQUETTE	COJINETE
2	36	1	671 021 830		FIXIERBLECH		FIXED PLATE	FIXATION	FIJACIÓN
2	37	1	671 001 019		ACHSE		AXLE	AXE	EJE
2	38	2	671 080 040		FEDERSCHEIBE		SPRING WASHER	RONDELLE A RESSORT	ARANDELA ELASTICO
2	39	2	671 201 501		SCHRAUBE	M5x10	TRIGGER BOLT	VIS	TORNILLO

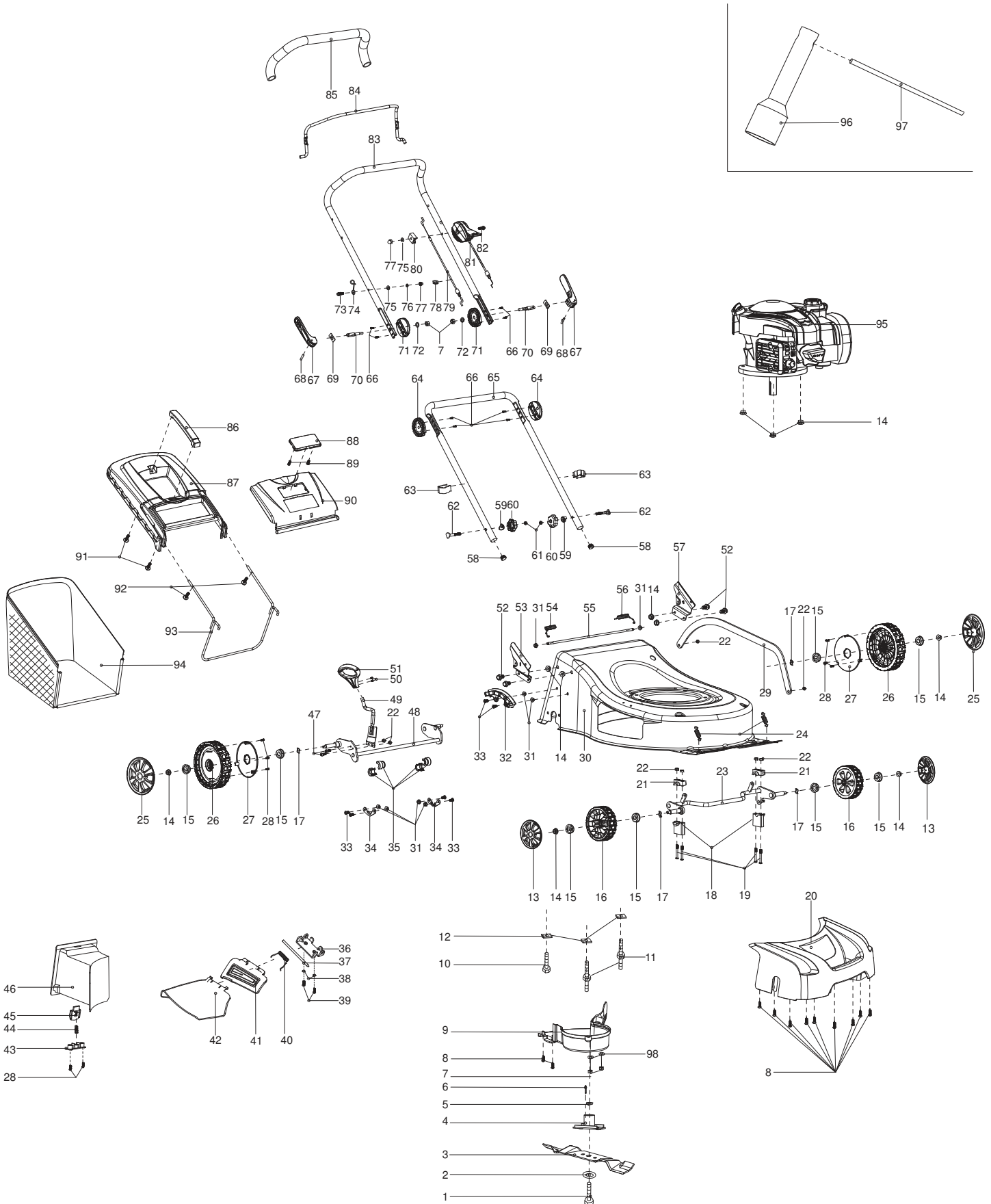

Seite / Page	Pos.	PLM4627	Teil-Nr. Part No. No. de pièce No. de pieza	Hinweise Notes Renseign. Nota	Bezeichnung	Spezifikation Specification	Description	Désignation	Denominación
2	40	1	671 111 300		DREHFEDER	φ3.1	TORSION SPRING	RESSORT DE TENSION	RESORTE DE TORSIÓN
2	41	1	671 380 001		MULCHABDECKUNG		SIDE DISCHARGE COVER	COUVERCLE	CUBIERTA
2	42	1	671 066 001		SCHUTZHAUBE SEITENAUSWURF		PROTECTION COVER	CAPOT DE PROTECTION	CUBIERTA PROTECTORA
2	43	1	671 317 001		DRUCKPLATTE		PRESSING PLATE	PLAQUE	PLACA
2	44	1	671 011 005		FEDER	φ8,0xφ0,9x31mm	SPRING	RESSORT	MUELLE
2	45	1	671 316 004		VERRIEGELUNGSKN OPF	20"	LOCKING BUTTON	TÊTE DE VERROUILLAGE	BOTÓN DE BLOQUEO
2	46	1	671 326 001		MULCHKEIL		MULCHING KIT	KIT MULCH	KIT DE MANTILLO
2	47	2	671 002 030		SCHRAUBE	M6x14	TRIGGER BOLT	VIS	TORNILLO
2	48	1	671 001 410		HINTERRADACHSE	18"	REAR WHEEL AXLE	AXE ROUE ARRIERES	EJE RUEDAS TRASERAS
2	49	1	671 001 411		HEBEL, HÖHENVERSTELLUNG	18"	HANDLE ASS'Y	LEVIER, REGLAGE HAUTEUR	PALANCA, AJUSTE ALTURA
2	50	2	671 003 033		SCHRAUBE	M5x8	SCREW	VIS	TORNILLO
2	51	1	671 010 590		GRIFF		GRIP	POIGNÉE	MANGO
2	52	4	671 006 064		6KT-SCHRAUBE	M8x6	HEXAGON HEAD BOLT	VIS À SIX PANS	TORNILLO HEXAGONAL
2	53	1	671 001 751		GRIFFANBINDUNG, RECHTS	18", MAKITA	BRACKET HANDLE, RIGHT	BRIDE DE POIGNÉE, DROITE	FIJACIÓN DE MANGO, DERECHA
2	54	1	671 011 113		DREHFEDER RECHTS		TORSION SPRING, RIGHT	RESSORT DE TENSION À DROITE	RESORTE DE TORSIÓN DERECHO
2	55	1	671 001 366		STANGE GRASKLAPPE	φ6,18"	LONG POLE	TRINGLE TRAPPE À HERBE	BARRA TAPA DE YERBA
2	56	1	671 011 114		DREHFEDER LINKS		TORSION SPRING, LEFT	RESSORT DE TENSION À GAUCHE	RESORTE DE TORSIÓN IZQUIERDO
2	57	1	671 001 750		GRIFFANBINDUNG, LINKS	18", MAKITA	BRACKET HANDLE, LEFT	BRIDE DE POIGNÉE, GAUCHE	FIJACIÓN DE MANGO, IZQ.
2	58	2	671 001 199		ROHRSTOPFEN	φ22mm	TUBE PLUG	BOUCHON DE TUBE	TAPÓN DE TUBO
2	59	2	671 001 085		SCHEIBE		WASHER	RONDELLE	ARANDELA
2	60	2	671 365 005		STERNGRIFFMUTTER		STAR KNOB	MANETTE	MANIJA DE ESTRELLA
2	61	2	671 005 023		6KT-MUTTER	M8	HEXAGONAL NUT	ECROU HEXAGONAL	TUERCA HEXAGONAL
2	62	2	671 006 004		FLACHKOPFSCHRAUBE	M8x52	FLAT HEAD BOLT	VIS À TÊTE CYLINDRIQUE	TORNILLO DE CABEZA PLANA
2	63	2	671 611 001		BOWDENZUGHALTER		BOWDEN CABLE CLAMP	COLLIER DE SERRANGE	SOPORTE DE CABLE BOWDEN
2	64	2	671 055 001		EINSTELLRING, UNTEN		LOWER ADJUSTING TOOTH RING	ANNEAU DE RÉGLAGE, INF.	ANILLO DE FLUJO, INF.
2	65	1	671 001 804		UNTERHOLM		LOWER HANDLE	MANCHE INFÉRIEURE	MANGO INFERIOR
2	66	8	671 001 049		SCHRAUBE	3x10	BOLT	VIS	TORNILLO
2	67	2	671 364 005		VERSTELLGRIFF		LOCKING HANDLE	POIGNÉE DE RÉGLAGE	AGARRE AJUSTABLE
2	68	2	671 090 048		ZYLINDERSTIFT	5x20	CYLINDRICAL PIN	GOUILLE CYLINDRIQUE	PASADOR CILINDRICO
2	69	2	671 001 119		DRUCKPLATTE		PRESSING PLATE	PLAQUE	PLACA
2	70	2	671 001 301		SCHRAUBE	M8x69	BOLT	VIS	TORNILLO
2	71	2	671 054 001		EINSTELLRING, OBEN		UPPER ADJUSTING TOOTH RING	ANNEAU DE RÉGLAGE, SUP.	ANILLO DE FLUJO, SUP.
2	72	2	671 011 890		FLACHSCHEIBE	φ16xφ8x0,8	FLAT WASHER	RONDELLE PLATE	ARANDELA
2	73	1	671 006 077		SCHRAUBE	M6x35	BOLT	VIS	TORNILLO
2	74	1	671 001 647		HAKEN		CABLE HOOK	TENON	GANCHO
2	75	3	671 007 008		SCHEIBE	φ16xφ8x0,8	WASHER	RONDELLE	ARANDELA
2	76	1	671 008 003		FEDERSCHEIBE	φ6,65	SPRING WASHER	RONDELLE A RESSORT	ARANDELA ELASTICO
2	77	2	671 050 160		6KT-MUTTER	M6	HEXAGONAL LOCKING NUT	ECROU HEXAGONAL	TUERCA HEXAGONAL

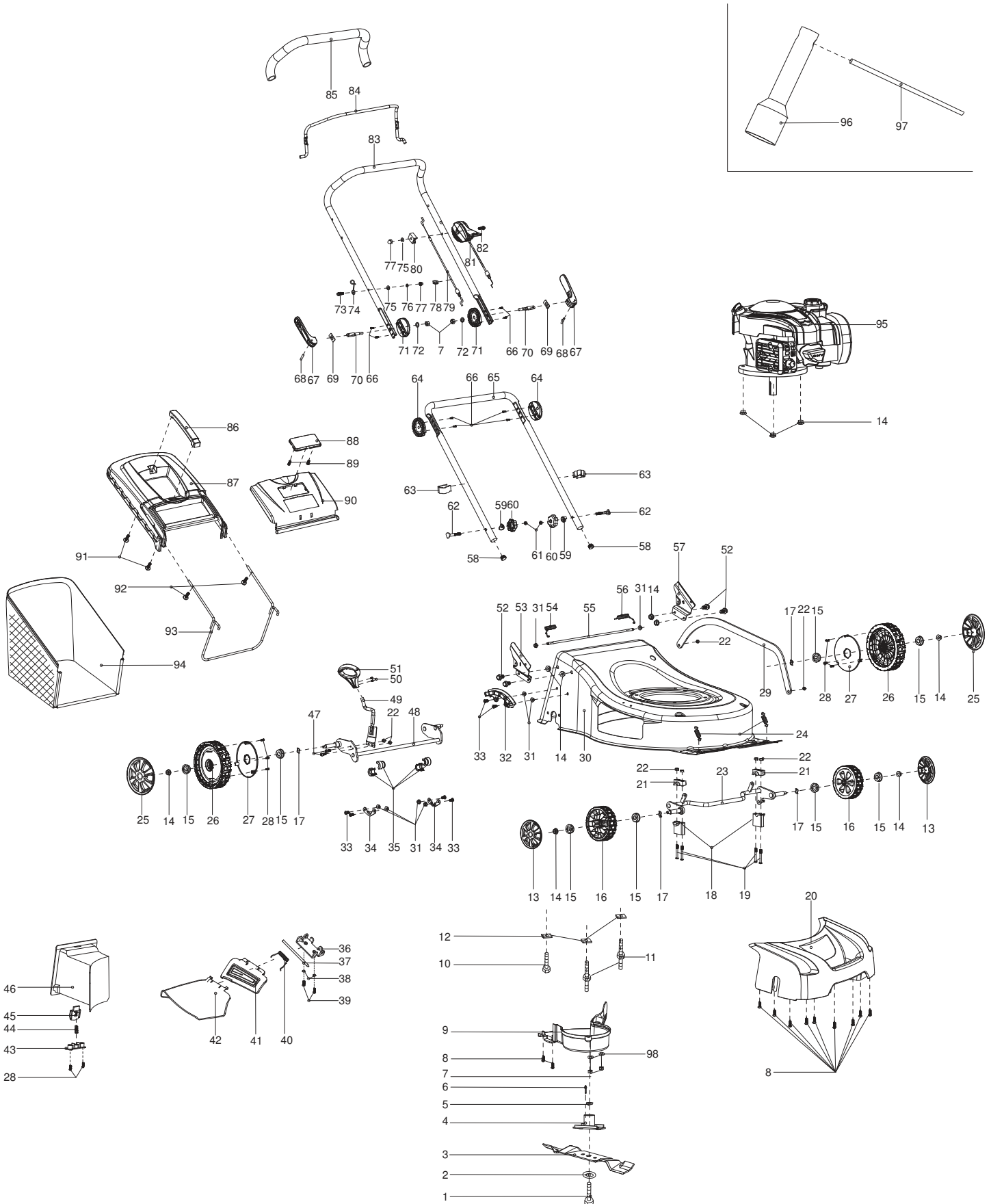

Seite / Page	Pos.	PLM4627	Teil-Nr. Part No. No. de pièce No. de pieza	Hinweise Notes Renseign. Nota	Bezeichnung	Spezifikation Specification	Description	Désignation	Denominación
2	78	1	671 800 104		GUMMITÜLLE		CORD PROTECTING SHEATH	PASSE-FIL	BOQUILLA DE CAUCHO
2	79	1	671 001 258		BOWDENZUG (MOTORBREMSE)	960mm	CONTROL CABLE (MOTOR BRAKE)	CÂBLE BOWDEN (FREIN MOTEUR)	TRACCIÓN BOWDEN (FRENO MOTOR)
2	80	1	671 336 001		HALTERUNG		FIXED BRACKET	FIXATION	SOPORTE
2	81	1	671 013 260		MOTORFERNBEDIEN UNG INKL. BOWDENZUG		THROTTLE HANDLE ASS'Y	LEVIER / CABLE, ACCELERATEUR	PALANCA / CABLE, ACELERADOR
2	82	1	671 006 119		SCHRAUBE	M6x60	BOLT	VIS	TORNILLO
2	83	1	671 017 970		OBERHOLM		UPPER HANDLE	MANCHE SUPÉRIEURE	MANGO SUPERIOR
2	84	1	671 017 580		HEBEL, MOTORBREMSE		LEVER, MOTOR BRAKE	LEVIER FREIN MOTEUR	PALANCA, FRENO MOTOR
2	85	1	671 001 029		GRIFFUMHÜLLUNG		HANDLE SHEATH	POIGNÉE	EMPUÑADURA
2	86	1	671 384 001		HANDGRIFF		GRASS CATCHER HANDLE	POIGNÉE	MANGO
2	87	1	671 382 001		KORB, OBERTEIL	60L	GRASS-BOX, UPPER	SAC, PARTIE	GESTO, SUPERIOR
2	88	1	671 385 001		SICHTFENSTER		TRANSPARENT WINDOW	REGARD	VENTANILLA
2	89	2	671 010 710		SCHRAUBE SELBSTSCHNEIDEN D	ST4x12	SELF-TAPPING SCREW	VIS DE FORAGE	TORNILLO PERFORADOR
2	90	1	671 004 272		HECKKLAPPE KPL.		REAR FLAP ASS'Y	HAYON CPL.	PORTÓN TRASERO CPL.
2	91	2	671 001 046		SCHRAUBE SELBSTSCHNEIDEN D	8x19	SELF-TAPPING SCREW	VIS DE FORAGE	TORNILLO PERFORADOR
2	92	2	671 001 032		SCHRAUBE	4,2x18	BOLT	VIS	TORNILLO
2	93	1	671 001 381		RAHMEN	18"/20"	GRASS CATCHER BRACKET	CADRE	MARKO
2	94	1	671 013 783		GRASFANGKORB	60L, MAKITA LOGO	GRASS CATCHER	SAC	GESTO
2	95	1			MOTOR	500/140CC/2.2KW /2850rpm, B&S, XAQ, MAKITA	ENGINE	MOTEUR	MOTOR
2	96	1	671 001 612		STECKSCHLÜSSEL	16mm	BOX SPANNER	CLÉ À DOUILLE	LLAVE
2	97	1	671 001 079		SPANNSTANGE	Φ8x110mm	SPANNER POLE	TIRANT	SENSOR
2	98	2	671 007 007		SCHEIBE	φ8	WASHER	RONDELLE	ARANDELA

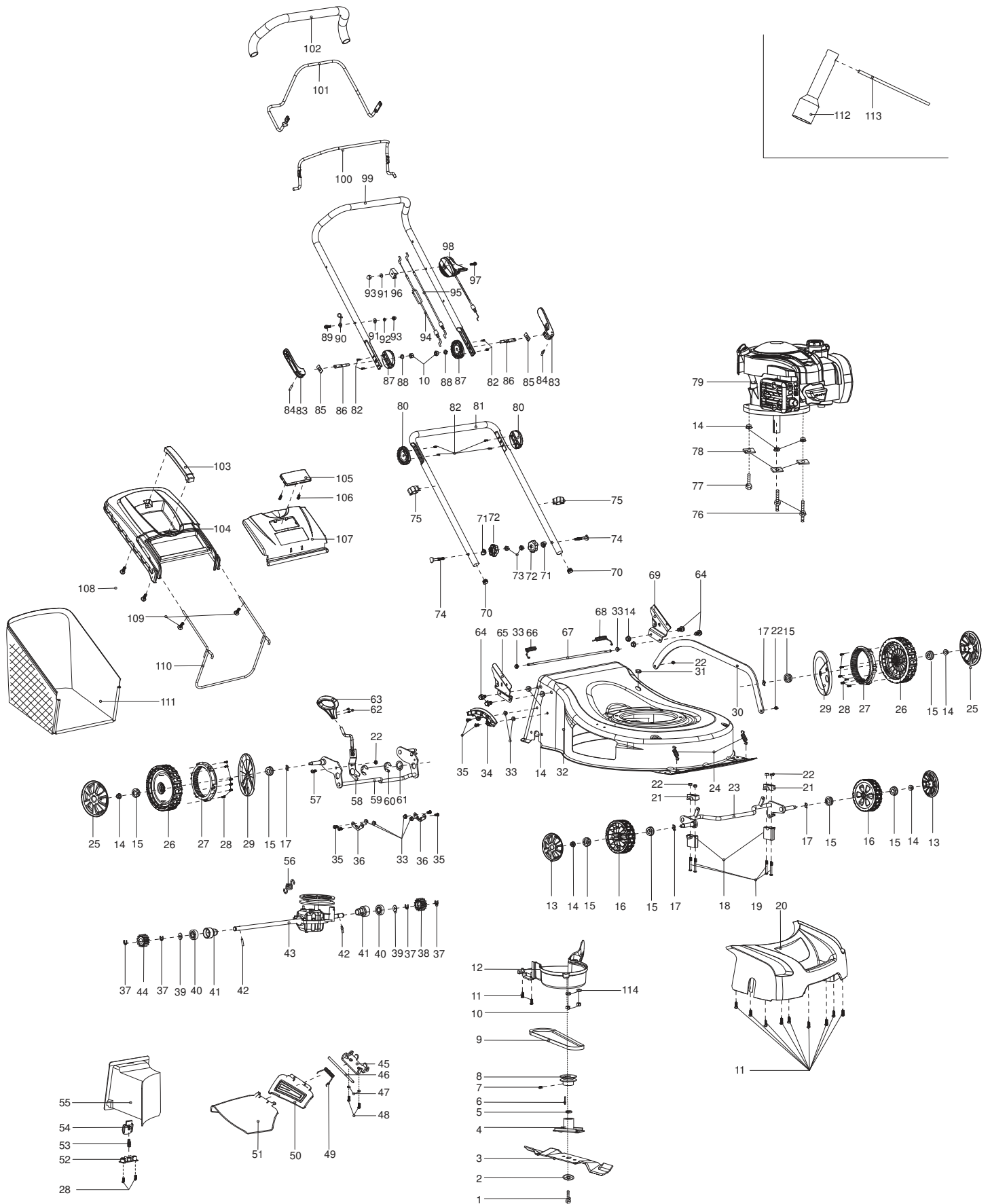

Seite / Page	Pos.	PLM4628	Teil-Nr. Part No. No. de pièce No. de pieza	Hinweise Notes Renseign. Nota	Bezeichnung	Spezifikation Specification	Description	Désignation	Denominación
3	1	1	671 006 062		MESSERSCHRAUBE	3/8", L=40mm	BLADE TIGHTEN SCREW	VIS DE LAME	TORNILLO DE LA CUCHILLA
3	2	1	671 010 730		SCHEIBE	Φ44.5/10.2x2.5	LID SHAPE WASHER	RONDELLE	ARANDELA
3	3	1	671 014 610		MESSER	460X55X4mm	BLADE	LAME	CUCHILLA
3	4	1	671 002 448		MESSERHALTER		BLADE SUPPORT	MOYEU	SOPORTE DE LA CUCHILLA
3	5	1	671 002 093		BUCHSE	Φ22.2xΦ10.5x7m m	BLADE SUPPORT BUSH	DOUILLE	CASQUILLO
3	6	1	671 090 077		PASSFEDER	4.7x4x4.7	FLAT KEY	CLAVETTE	CHAVETA
3	7	1	671 030 050		6KT-SCHRAUBE	M6x8	HEXAGON HEAD BOLT	VIS À SIX PANS	TORNILLO HEXAGONAL
3	8	1	671 004 002		RIEMENSCHLEIBE	45	PULLEY	POULIE À GORGE POUR COURROIE	DISCO DE LA CORREA
3	9	1	671 012 720		KEILRIEMEN	Li=762mm	V-BELT	COURROIE TRAPÉZOIDALE	CORREA TRAPEZOIDAL
3	10	4	671 005 008		6KT-MUTTER	M8	HEXAGONAL LOCKING NUT	ECROU HEXAGONAL	TUERCA HEXAGONAL
3	11	11	671 001 037		SCHRAUBE SELBSTSCHNEIDEN D	5x16	SELF-TAPPING SCREW	VIS DE FORAGE	TORNILLO PERFORADOR
3	12	1	671 558 001		RIEMENABDECKUNG		BELT PROTECTION COVER	COUVERCLE DE COURROIE	CUBIERTA DE CORREA
3	13	2	671 105 103		RADKAPPE	8"	WHEEL COVER	CHAPEAU DE MOYEU	CAPERUZA DE RUEDA
3	14	11	671 005 028		6KT-MUTTER	M8	HEXAGONAL LOCKING NUT	ECROU HEXAGONAL	TUERCA HEXAGONAL
3	15	8	671 040 160		LAGER		BEARING	ROULEMENT	RODAMIENTO
3	16	2	671 204 301		RAD KPL.	8"	WHEEL ASS'Y	ROUE CPL.	RUEDA CPL.
3	17	4	671 007 062		WELLENSCHLEIBE	φ12xφ18x0.5	WAVE WASHER	RONDELLE	ARANDELA
3	18	2	671 376 001		LAGERSCHALE		LOWER SUPPORT OF WHEEL AXIS	COQUILLE DE COUSSINET	MITAD DE RODAMIENTO
3	19	4	671 006 119		SCHRAUBE	M6x60	BOLT	VIS	TORNILLO
3	20	1	671 536 001		FRONTTEIL	18"	FRONT COVER	PANNEAU	FRONTAL CUBIERTA
3	21	2	671 376 002		LAGERSCHALE		UPPER SUPPORT OF WHEEL AXIS	COQUILLE DE COUSSINET	MITAD DE RODAMIENTO
3	22	7	671 005 005		6KT-MUTTER	M6	LOCKING NUT	ECROU	TUERCA
3	23	1	671 001 374		VORDERACHSE	18"	FRONT WHEEL AXLE	ESSIEU AVANT	EJE DELANTERO
3	24	2	671 011 112		ZUGFEDER		EXTENSION SPRING OF FRONT WHEEL AXLE	RESSORT	RESORTE
3	25	2	671 010 530		RADKAPPE	11"	WHEEL COVER	CHAPEAU DE MOYEU	CAPERUZA DE RUEDA
3	26	2	671 020 440		RAD KPL.		WHEEL ASS'Y	ROUE CPL.	RUEDA CPL.
3	27	2	671 295 001		ZAHNRAD	11"	GEAR WHEEL	ROUE DENTEE	PIÑÓN
3	28	12	671 107 301		SCHRAUBE SELBSTSCHNEIDEN D	ST4x16	SELF-TAPPING SCREW	VIS DE FORAGE	TORNILLO PERFORADOR
3	29	2	671 087 001		STAUBSCHUTZABDE CKUNG		DUST COVER	COUVERCLE	CUBIERTA
3	30	1	671 001 377		VERBINDUNGSSTAN GE	18"	LINK ROD	BARRE DE RACCORDEMENT	BARRA DE CONEXIÓN
3	31	1	671 800 104		GUMMITÜLLE		CORD PROTECTING SHEATH	PASSE-FIL	BOQUILLA DE CAUCHO
3	32	1	671 010 054		DECK	18", MAKITA	DECK	CAPOT	CAPOTA
3	33	8	671 005 024		6KT-MUTTER	M6	HEXAGONAL LOCKING NUT	ECROU HEXAGONAL	TUERCA HEXAGONAL
3	34	1	671 001 025		DREHPUNKT FÜR HÖHENVERSTELLUN G	18"	HEIGHT ADJUSTMENT PLATE	POINT DE ROTATION POUR LE RÉGLAGE EN HAUTEUR	PUNTO DE GIRO PARA REGLAJE DE ALTURA
3	35	6	671 002 019		SCHRAUBE	M6x12	TRIGGER BOLT	VIS	TORNILLO
3	36	2	671 001 244		FIXIERUNG		RING OF AXLE FIXING	FIXATION	FIJACIÓN
3	37	4	671 090 020		SICHERUNGSSCHEI BE		SAFETY WASHER	RONDELLE SÉCURITÉ	ARANDELA SEGURIDAD

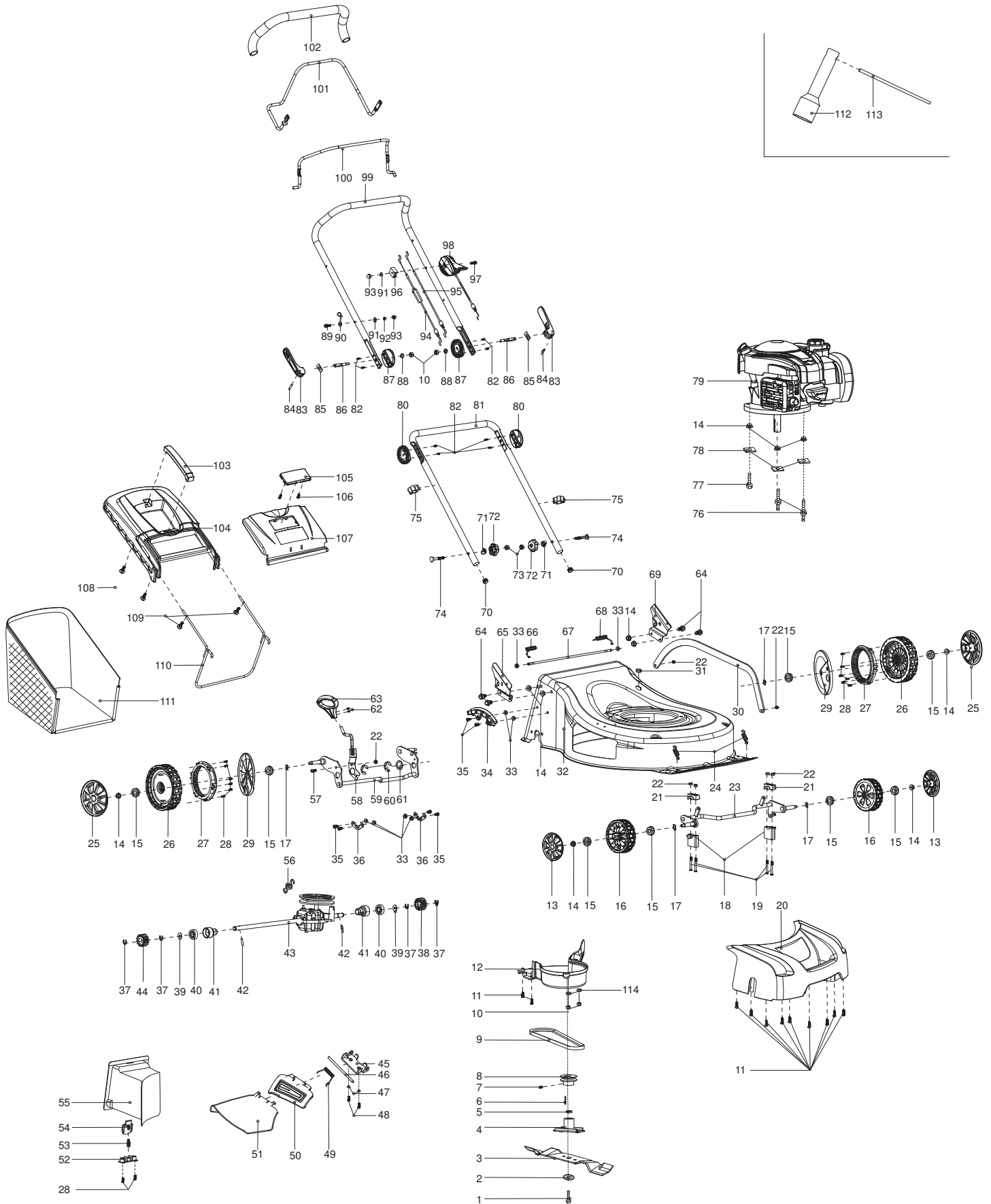

PLM4626, PLM4627,
PLM4628

3

PM-46 SB, PLM4628
PM-46 SB, PLM4628
PM-46 SB, PLM4628
PM-46 SB, PLM4628



Seite / Page	Pos.	PLM4628	Teil-Nr. Part No. No. de pièce No. de pieza	Hinweise Notes Renseign. Nota	Bezeichnung	Spezifikation Specification	Description	Désignation	Denominación
3	38	1	671 003 001		ZAHNRAD, LINKS		GEAR WHEEL, LEFT	ROUE DENTEE, GAUCHE	PIÑON, IZQ.
3	39	2	671 007 051		FLACHSCHEIBE	φ12.8xφ20x0.8	FLAT WASHER	RONDELLE PLATE	ARANDELA
3	40	2	671 004 023		LAGER		BEARING	ROULEMENT	RODAMIENTO
3	41	2	671 002 031		LAGERGEHÄUSE		BEARING HOUSING	CARTER	CÁRTER
3	42	2	671 090 001		ZYLINDERSTIFT	φ5x21.5	CYLINDRICAL PIN	GOUILLE CYLINDRIQUE	PASADOR CILINDRICO
3	43	1	671 501 028		ANTRIEB	18"	GEAR BOX	GROUPE TRACTION	UNIDAD DE TRACCIÓN
3	44	1	671 003 002		ZAHNRAD, RECHTS		RIGHT GEAR	ROUE DENTEE, DROITE	PIÑON, DERECHA
3	45	1	671 021 830		FIXIERBLECH		FIXED PLATE	FIXATION	FIJACIÓN
3	46	1	671 001 019		ACHSE		AXLE	AXE	EJE
3	47	2	671 080 040		FEDERSCHEIBE		SPRING WASHER	RONDELLE A RESSORT	ARANDELA ELASTICO
3	48	2	671 201 501		SCHRAUBE	M5x10	TRIGGER BOLT	VIS	TORNILLO
3	49	1	671 111 300		DREHFEDER	φ3.1	TORSION SPRING	RESSORT DE TENSION	RESORTE DE TORSIÓN
3	50	1	671 380 001		MULCHABDECKUNG		SIDE DISCHARGE COVER	COUVERCLE	CUBIERTA
3	51	1	671 066 001		SCHUTZHAUBE SEITENAUSWURF		PROTECTION COVER	CAPOT DE PROTECTION	CUBIERTA PROTECTORA
3	52	1	671 317 001		DRUCKPLATTE		PRESSING PLATE	PLAQUE	PLACA
3	53	1	671 011 005		FEDER	φ8,0xφ0,9x31mm	SPRING	RESSORT	MUELLE
3	54	1	671 316 004		VERRIEGELUNGSKN OPF	20"	LOCKING BUTTON	TÊTE DE VERROUILLAGE	BOTÓN DE BLOQUEO
3	55	1	671 326 001		MULCHKEIL		MULCHING KIT	KIT MULCH	KIT DE MANTILLO
3	56	1	671 011 174		DREHFEDER		SPRING OF GEAR BOX	RESSORT DE TENSION	RESORTE DE TORSIÓN
3	57	1	671 002 030		SCHRAUBE	M6x14	TRIGGER BOLT	VIS	TORNILLO
3	58	1	671 001 396		HEBEL, HÖHENVERSTELLUN G		LEVER, HEIGHT ADJUSTMENT	LEVIER, REGLAGE HAUTEUR	PALANCA, AJUSTE ALTURA
3	59	1	671 001 372		HINTERRADACHSE		REAR WHEEL AXLE	AXE ROUE ARRIERES	EJE RUEDAS TRASERAS
3	60	2	671 009 003		SICHERUNGSSCHEI BE	φ19x1.5	SAFETY WASHER	RONDELLE SÉCURITÉ	ARANDELA SEGURIDAD
3	61	1	671 001 076		FEDERSCHEIBE	φ35xφ22.5x1.5	SPRING WASHER	RONDELLE A RESSORT	ARANDELA ELASTICO
3	62	2	671 003 033		SCHRAUBE	M5x8	SCREW	VIS	TORNILLO
3	63	1	671 010 590		GRIFF		GRIP	POIGNÉE	MANGO
3	64	4	671 006 064		6KT-SCHRAUBE	M8x6	HEXAGON HEAD BOLT	VIS À SIX PANS	TORNILLO HEXAGONAL
3	65	1	671 001 751		GRIFFANBINDUNG, RECHTS	18", MAKITA	BRACKET HANDLE, RIGHT	BRIDE DE POIGNÉE, DROITE	FIJACIÓN DE MANGO, DERECHA
3	66	1	671 011 113		DREHFEDER RECHTS		TORSION SPRING, RIGHT	RESSORT DE TENSION À DROITE	RESORTE DE TORSIÓN DERECHO
3	67	1	671 001 366		STANGE GRASKLAPPE	φ6,18"	LONG POLE	TRINGLE TRAPPE À HERBE	BARRA TAPA DE YERBA
3	68	1	671 011 114		DREHFEDER LINKS		TORSION SPRING, LEFT	RESSORT DE TENSION À GAUCHE	RESORTE DE TORSIÓN IZQUIERDO
3	69	1	671 001 750		GRIFFANBINDUNG, LINKS	18", MAKITA	BRACKET HANDLE, LEFT	BRIDE DE POIGNÉE, GAUCHE	FIJACIÓN DE MANGO, IZQ.
3	70	2	671 001 199		ROHRSTOPFEN	φ22mm	TUBE PLUG	BOUCHON DE TUBE	TAPÓN DE TUBO
3	71	2	671 001 085		SCHLEIFE		WASHER	RONDELLE	ARANDELA
3	72	2	671 365 005		STERNGRIFFMUTTE R		STAR KNOB	MANETTE	MANIJA DE ESTRELLA
3	73	2	671 005 023		6KT-MUTTER	M8	HEXAGONAL NUT	ECROU HEXAGONAL	TUERCA HEXAGONAL
3	74	2	671 006 004		FLACHKOPFSCHRAU BE	M8x52	FLAT HEAD BOLT	VIS À TÊTE CYLINDRIQUE	TORNILLO DE CABEZA PLANA
3	75	2	671 611 001		BOWDENZUGHALTE R		BOWDEN CABLE CLAMP	COLLIER DE SERRANGE	SOPORTE DE CABLE BOWDEN

PLM4626, PLM4627,
PLM4628

3

PM-46 SB, PLM4628
PM-46 SB, PLM4628
PM-46 SB, PLM4628
PM-46 SB, PLM4628



Seite / Page	Pos.	PLM4628	Teil-Nr. Part No. No. de pièce No. de pieza	Hinweise Notes Renseign. Nota	Bezeichnung	Spezifikation Specification	Description	Désignation	Denominación
3	76	2	671 003 044		SPEZIALSCHRAUBE	M8x17x35	SPECIAL SCREW	VIS SPÉCIALE	TORNILLO ESPECIAL
3	77	1	671 006 025		6KT-SCHRAUBE	M8x35	HEXAGON BOLT	VIS À SIX PANS	TORNILLO HEXAGONAL
3	78	3	671 002 106		4KT-SCHEIBE	φ10	SQUARE GASKET	RONDELLE	ARANDELA
3	79	1			MOTOR	500/140CC/2.2KW /2850rpm, B&S, XAQ, MAKITA	ENGINE	MOTEUR	MOTOR
3	80	2	671 055 001		EINSTELLRING, UNTEN		LOWER ADJUSTING TOOTH RING	ANNEAU DE RÉGLAGE, INF.	ANILLO DE FLUJO, INF.
3	81	1	671 001 804		UNTERHOLM		LOWER HANDLE	MANCHE INFÉRIEURE	MANGO INFERIOR
3	82	8	671 001 049		SCHRAUBE	3x10	BOLT	VIS	TORNILLO
3	83	2	671 364 005		VERSTELLGRIF		LOCKING HANDLE	POIGNÉE DE RÉGLAGE	AGARRE AJUSTABLE
3	84	2	671 090 048		ZYLINDERSTIFT	5x20	CYLINDRICAL PIN	GOUILLE CYLINDRIQUE	PASADOR CILINDRICO
3	85	2	671 001 119		DRUCKPLATTE		PRESSING PLATE	PLAQUE	PLACA
3	86	2	671 001 301		SCHRAUBE	M8x69	BOLT	VIS	TORNILLO
3	87	2	671 054 001		EINSTELLRING, OBEN		UPPER ADJUSTING TOOTH RING	ANNEAU DE RÉGLAGE, SUP.	ANILLO DE FLUJO, SUP.
3	88	2	671 011 890		FLACHSCHEIBE	φ16xφ8x0,8	FLAT WASHER	RONDELLE PLATE	ARANDELA
3	89	1	671 006 077		SCHRAUBE	M6x35	BOLT	VIS	TORNILLO
3	90	1	671 001 647		HAKEN		CABLE HOOK	TENON	GANCHO
3	91	3	671 007 008		SCHEIBE	φ16xφ8x0,8	WASHER	RONDELLE	ARANDELA
3	92	1	671 008 003		FEDERSCHEIBE	φ6,65	SPRING WASHER	RONDELLE A RESSORT	ARANDELA ELASTICO
3	93	2	671 050 160		6KT-MUTTER	M6	HEXAGONAL LOCKING NUT	ECROU HEXAGONAL	TUERCA HEXAGONAL
3	94	1	671 001 258		BOWDENZUG (MOTORBREMSE)	960mm	CONTROL CABLE (MOTOR BRAKE)	CÂBLE BOWDEN (FREIN MOTEUR)	TRACCIÓN BOWDEN (FRENO MOTOR)
3	95	1	671 001 222		BOWDENZUG (RADANTRIEB)		CONTROL CABLE (WHEEL DRIVE)	CÂBLE BOWDEN (ENTRAÎNEMENT DE ROUE)	TRACCIÓN BOWDEN (TRACCIÓN DE RUEDA)
3	96	1	671 336 001		HALTERUNG		FIXED BRACKET	FIXATION	SOPORTE
3	97	1	671 006 119		SCHRAUBE	M6x60	BOLT	VIS	TORNILLO
3	98	1	671 013 260		MOTORFERNBEDIEN UNG INKL. BOWDENZUG		THROTTLE HANDLE ASS'Y	LEVIER / CABLE, ACCELERATEUR	PALANCA / CABLE, ACELERADOR
3	99	1	671 017 970		OBERHOLM		UPPER HANDLE	MANCHE SUPÉRIEURE	MANGO SUPERIOR
3	100	1	671 017 580		HEBEL, MOTORBREMSE		LEVER, MOTOR BRAKE	LEVIER FREIN MOTEUR	PALANCA, FRENO MOTOR
3	101	1	671 001 732		HEBEL, ANTRIEB	18"	LEVER, DRIVING	LEVIER TRACTION	PALANCA, CONDUCCIÓN
3	102	1	671 001 029		GRIFFUMHÜLLUNG		HANDLE SHEATH	POIGNÉE	EMPUÑADURA
3	103	1	671 384 001		HANDGRIF		GRASS CATCHER HANDLE	POIGNÉE	MANGO
3	104	1	671 382 001		KORB, OBERTEIL	60L	GRASS-BOX, UPPER	SAC, PARTIE	GESTO, SUPERIOR
3	105	1	671 385 001		SICHTFENSTER		TRANSPARENT WINDOW	REGARD	VENTANILLA
3	106	2	671 010 710		SCHRAUBE SELBSTSCHNEIDEN D	ST4x12	SELF-TAPPING SCREW	VIS DE FORAGE	TORNILLO PERFORADOR
3	107	1	671 004 272		HECKKLAPPE KPL.		REAR FLAP ASS'Y	HAYON CPL.	PORTÓN TRASERO CPL.
3	108	2	671 001 046		SCHRAUBE SELBSTSCHNEIDEN D	8x19	SELF-TAPPING SCREW	VIS DE FORAGE	TORNILLO PERFORADOR
3	109	2	671 001 032		SCHRAUBE	4,2x18	BOLT	VIS	TORNILLO
3	110	1	671 001 381		RAHMEN	18"/20"	GRASS CATCHER BRACKET	CADRE	MARKO
3	111	1	671 013 783		GRASFANGKORB	60L, MAKITA LOGO	GRASS CATCHER	SAC	GESTO
3	112	1	671 001 612		STECKSCHLÜSSEL	16mm	BOX SPANNER	CLÉ À DOUILLE	LLAVE

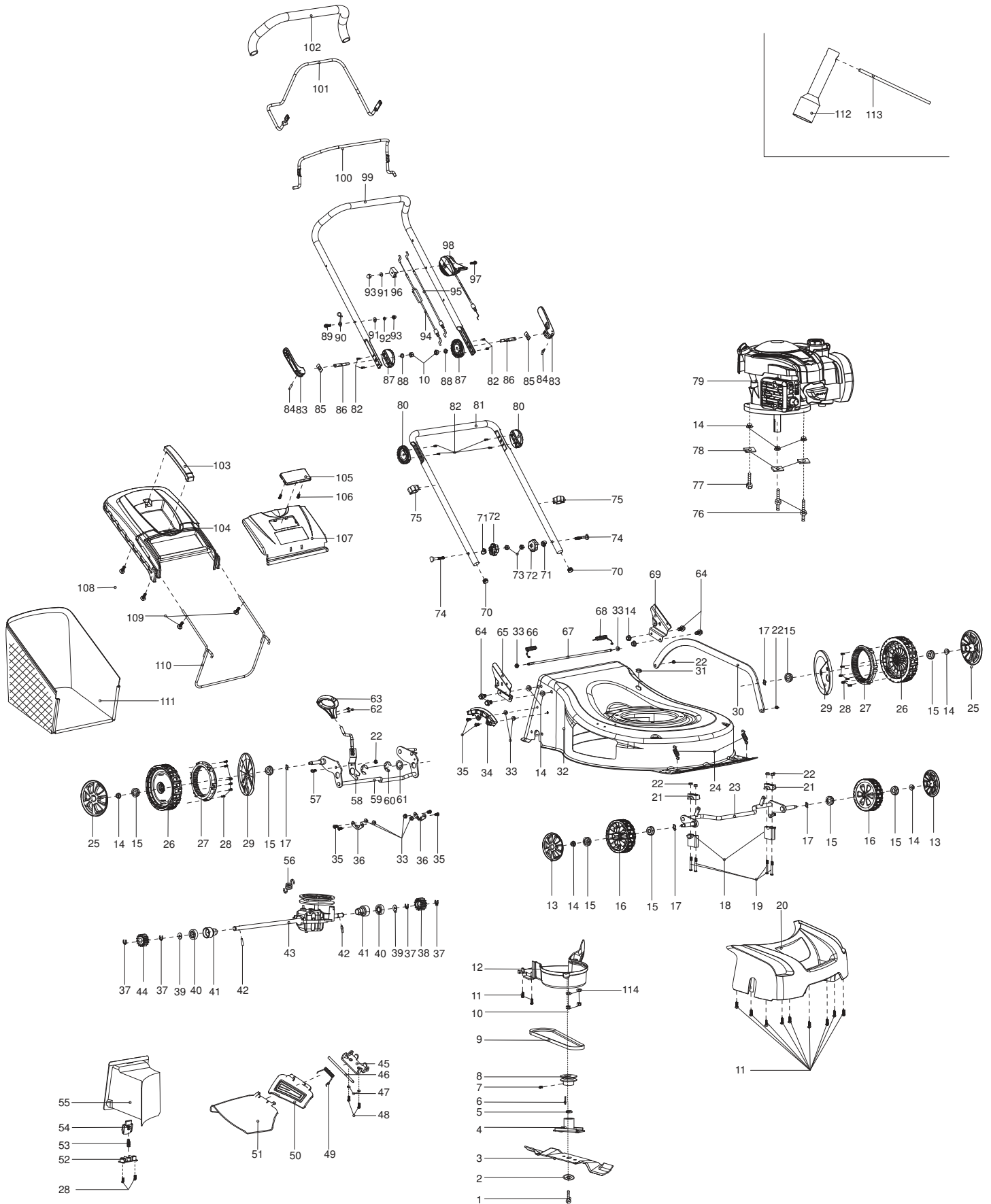

PLM4626, PLM4627,
PLM4628

3

PM-46 SB, PLM4628
PM-46 SB, PLM4628
PM-46 SB, PLM4628
PM-46 SB, PLM4628



Seite / Page	Pos.	PLM4628	Teil-Nr. Part No. No. de pièce No. de pieza	Hinweise Notes Renseign. Nota	Bezeichnung	Spezifikation Specification	Description	Désignation	Denominación
3	113	1	671 001 079		SPANNSTANGE	Φ8x110mm	SPANNER POLE	TIRANT	TENSOR
3	114	2	671 007 007		SCHEIBE	φ8	WASHER	RONDELLE	ARANDELA

- 1** PM-46 B, PLM4626
PM-46 B, PLM4626
PM-46 B, PLM4626
PM-46 B, PLM4626
- 2** PM-46 NB, PLM4627
PM-46 NB, PLM4627
PM-46 NB, PLM4627
PM-46 NB, PLM4627
- 3** PM-46 SB, PLM4628
PM-46 SB, PLM4628
PM-46 SB, PLM4628
PM-46 SB, PLM4628

	Zeichenerklärung	Key to symbols
<p>⇒ 1999999 2000000 ⇒ 2003.04 ⇒ TI 2003/07 Acc. = { m Corr.</p>	<p>Produktion bis Serien-Nr. Neues Teil ab Serien-Nr. Neues Teil ab Jahr / Monat Siehe Technische Information Jahr / Nr. Zubehör (nicht im Lieferumfang) Keine Serienausführung, jedoch verwendbar Beinhaltet Positions-Nr. Meterware Druckfehlerberichtigung</p>	<p>Production to serial number New part from serial number New part from Year / Month See Technical Information Year / No. Accessories (not included in the delivery inventory) No standard execution, may be used Contains item number Sold by the meter Error correction</p>
	Änderungen vorbehalten	Specifications subject to change without notice
	Légende	Explicación de símbolos
<p>⇒ 1999999 2000000 ⇒ 2003.04 ⇒ TI 2003/07 Acc. = { m Corr.</p>	<p>Production jusqu'à n° de série Nouveau pièce à partir du n° de série Nouveau pièce à partir de année / mois Voir information technique année / n° Accessoires (non compris dans la livraison) Aucune exécut. en série, cependant utilisable contient n° de numéro Au mètre Rectification d'erreurs</p>	<p>Producción hasta N° de serie Pieza nueva a partir de N° de serie Pieza nueva a partir de año / mes Véase inform. técnico año / N° Accesorios (no incluido en la extensión del suministro) No es de serie, pero sirve Contiene pos N° Por metro Fe de erratas</p>
	Changements sans préavis	Mejoras constructivas sin previo aviso

