



GB Petrol Lawn Mower

Original Instruction manual

PLM4120N
PLM4620N2



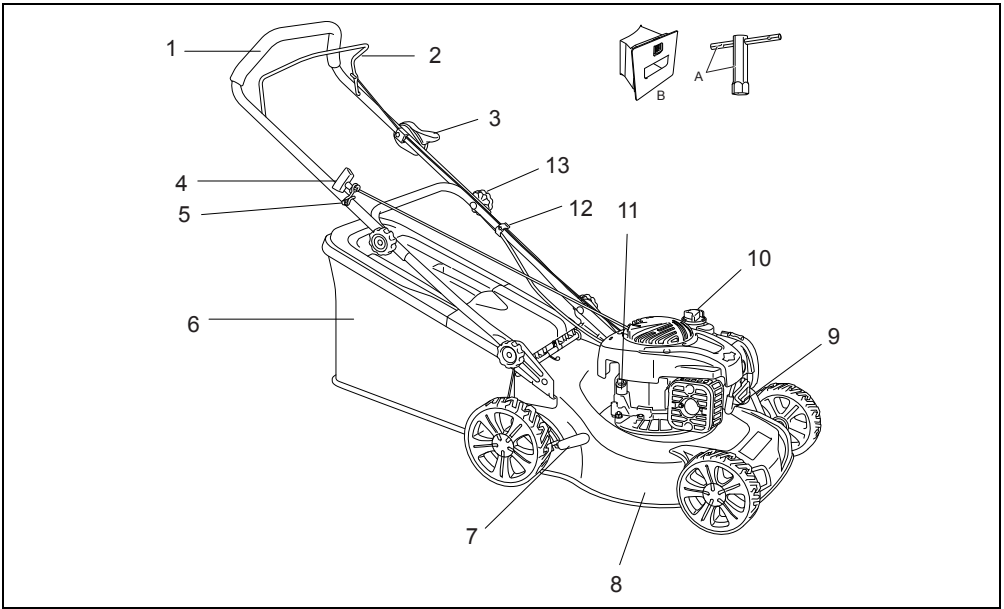

1 PLM4120N

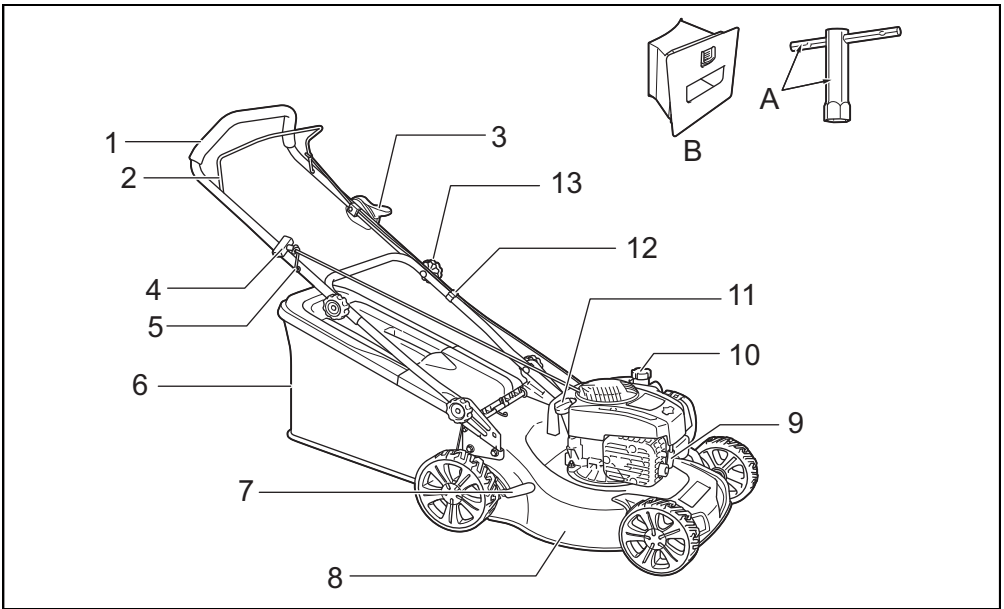

2 PLM4620N2

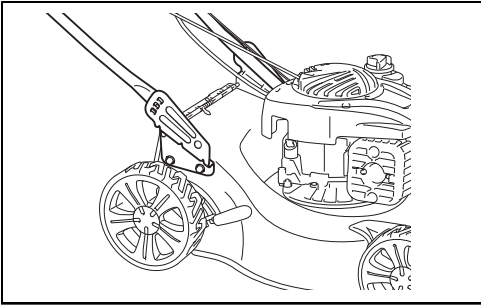

3

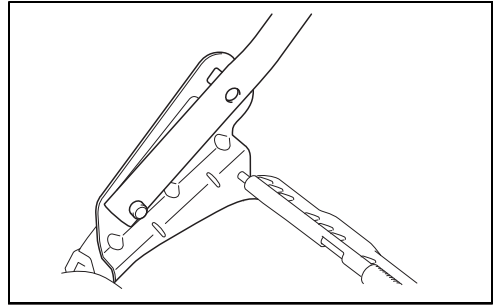

4

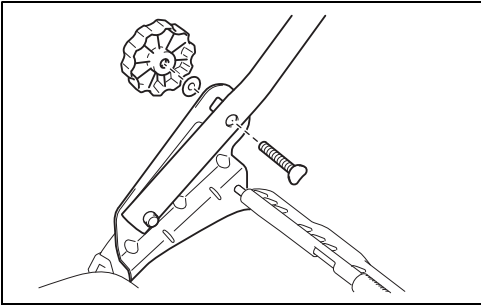

5

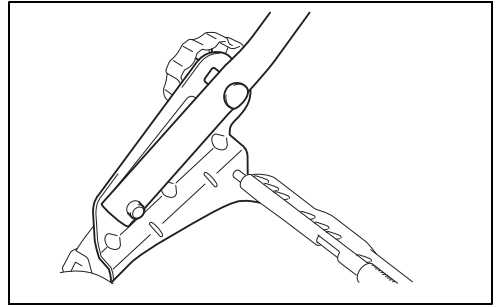

6

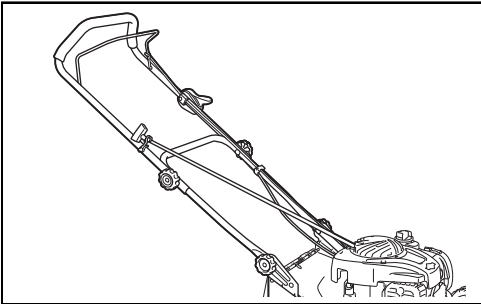

7

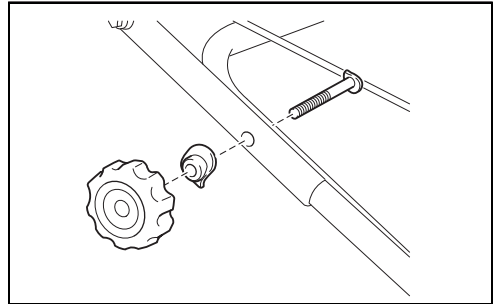

8

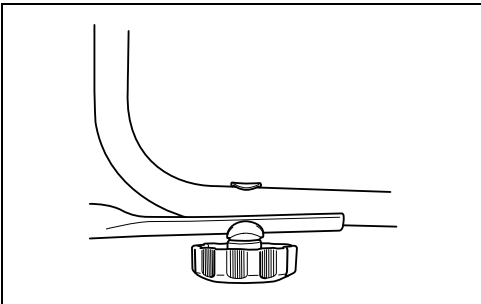

9

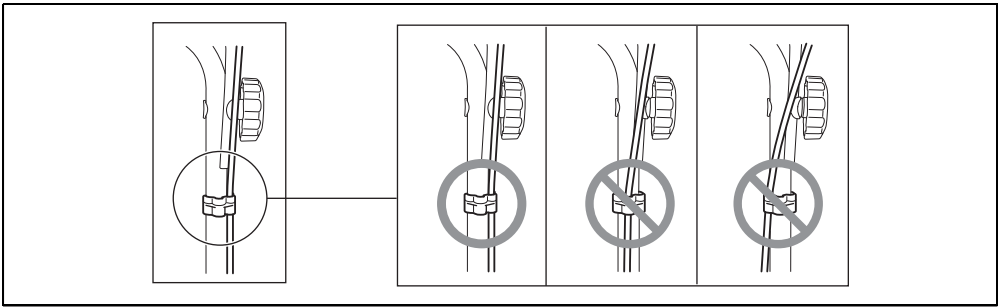

10

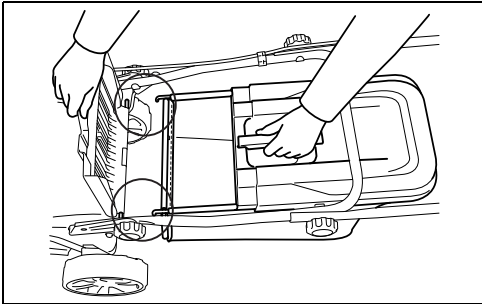

11

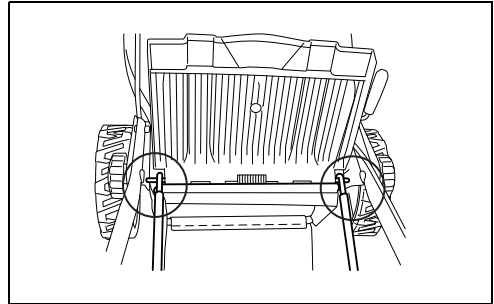

12

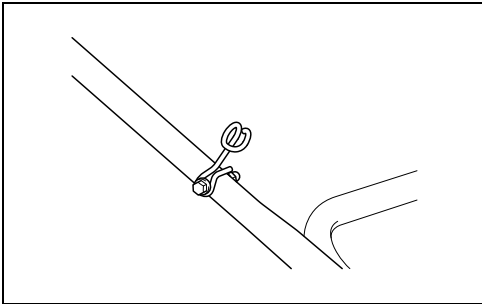

13

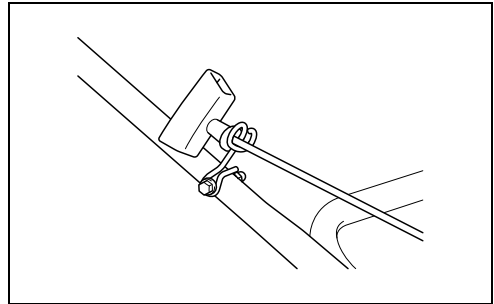

14

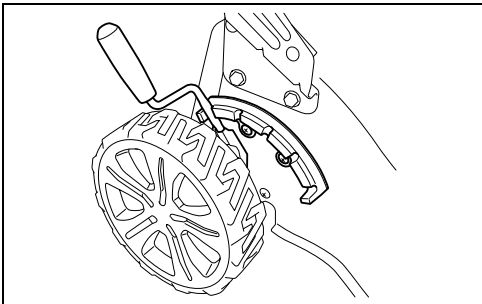

15

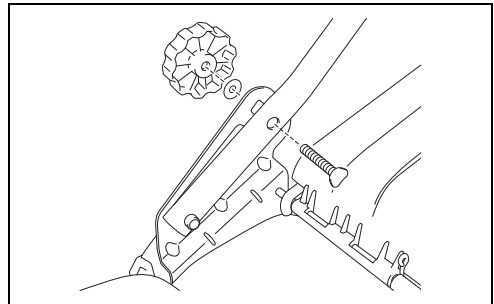

16

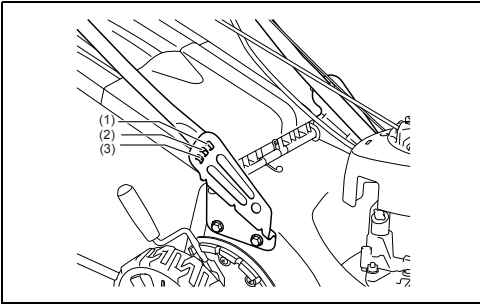

17

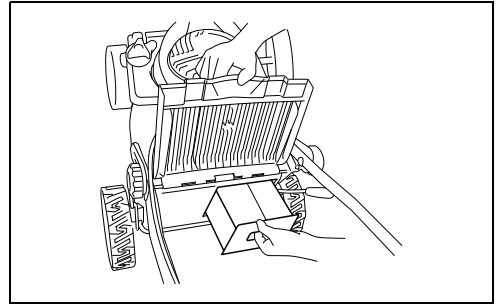

18

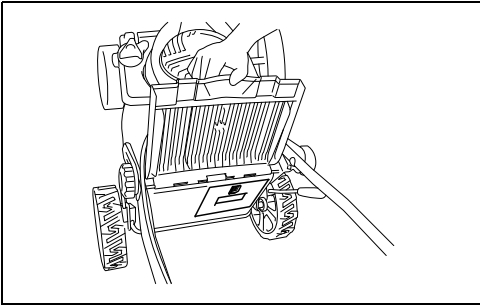

19

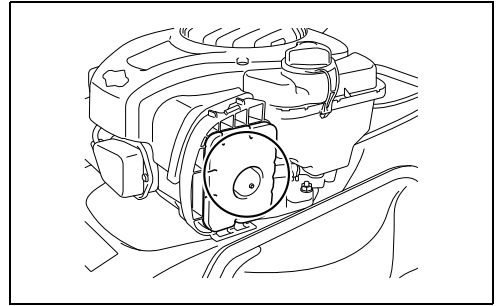

20

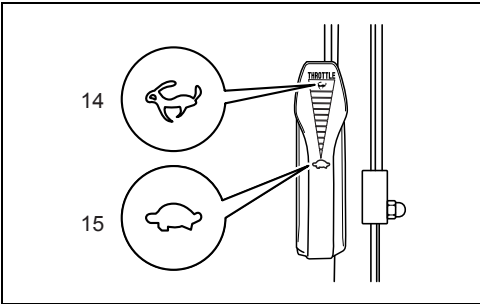

21

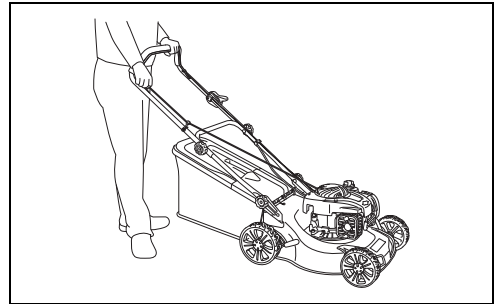

22

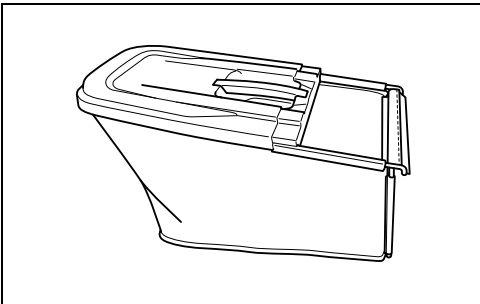

23

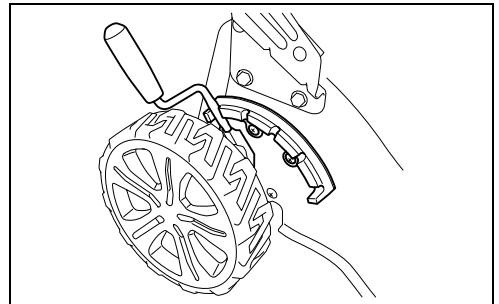

24

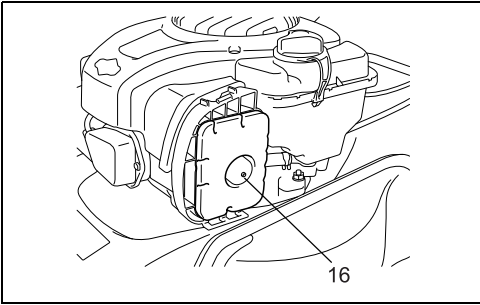

25A For PLM4120N

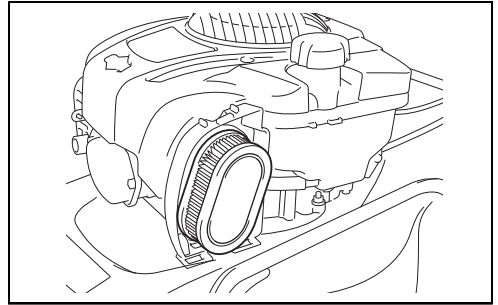

25B For PLM4620N2

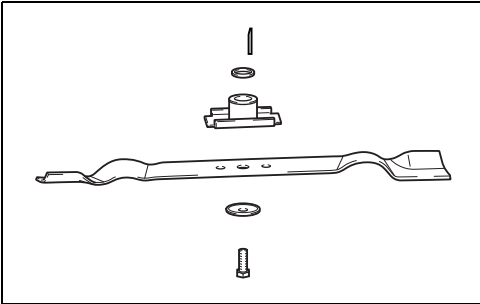

26

CONTENTS

ENGLISH.....

Explanation of general view

- | | | |
|-------------------------|---------------------------|------------------|
| 1. Upper handle | 7. Height adjusting lever | 13. Locking knob |
| 2. Stop control handle | 8. Deck | 14. Fast speed |
| 3. Throttle choke lever | 9. Spark Plug | 15. Slow speed |
| 4. Starter handle | 10. Fuel cap | 16. Primer bulb |
| 5. Rope guide | 11. Oil cap | |
| 6. Grass catcher | 12. Cable clamp | |



WARNING

For your own safety please read this manual before attempting to operate your new unit. Failure to follow instructions can result in serious personal injury. Spend a few moments to familiarize yourself with your mower before each use. Keep this manual in a safe place, so that the information is available at all times. If you give the equipment to any other person, hand over these operating instructions and safety regulations as well.

Intended use

The equipment may only be used for the tasks it is designed to handle. Any other use is deemed to be a case of misuse. The user/operator and not the manufacturer will be liable for any damage or injuries of any kind caused as a result of this.

The petrol lawn mower is intended for private use i.e. for use in home and gardening environments.

Private use of the lawn mower refers an annual operating time generally not exceeding that of 50 hours, during which time the machine is primarily used to maintain small-scale, residential lawns and home/hobby gardens. Public facilities, sporting halls, and agricultural/forestry applications are excluded.

Please note that our equipment has not been designed for use in commercial, trade or industrial applications. Our warranty will be voided if the machine is used in commercial, trade or industrial businesses or for equivalent purposes.

The operating instructions as supplied by the manufacturer must be kept and referred to in order to ensure that the lawn mower is properly used and maintained. The instructions contain valuable information on operating, maintenance and servicing conditions.

Important! Due to the high risk of bodily injury to the user, the lawn mower may not be used to trim bushes, hedges or shrubs, to cut scaling vegetation, planted roofs, or balcony-grown grass, to clean (suck up) dirt and debris off walkways, or to chop up tree or hedge clippings.

Moreover, the lawn mower may not be used as a power cultivator to level out high areas such as molehills.

For safety reasons, the lawn mower may not be used as a drive unit for other work tools or tool kits of any kind.

1. SYMBOLS MARKED ON THE PRODUCT (ON THE REAR COVER)



Read operator's manual.



Keep bystanders away.



Pay more attention to the operator's hands and feet to avoid injured.



Toxic fumes; Don't operate inside house.



Fuel is flammable, keep fire away. Do not add fuel with running machine.



When mowing, please wear the glasses and ear plugs to defend the operator himself.



When repairing, please pick up the spark plug, then repairs it according to the operational manual.



Caution: Engine hot.

2. GENERAL SAFETY RULES



WARNING: When using petrol tools, basic safety precautions, including the following, should always be followed to reduce the risk of serious personal injury and/or damage to the unit.

Read all these instructions before operating this product and retain these instructions for future reference.



WARNING: This machine produces an electromagnetic field during operation. Under some circumstances this field may interfere with active or passive medical implants. To reduce the risk of serious or fatal injury, we recommend persons with medical implants to consult their physician and the medical implant manufacturer before operating this machine.

Training

- Read the instructions carefully. Be familiar with the controls and the proper use of the equipment. Learn how to stop the engine quickly.
- Only use the lawn mower for the purpose for which it was designed, i.e. for cutting and collecting grass. Any other use can be hazardous, causing damage to the machine. Examples of improper use may include, but are not limited to:
 - transport of people, children or animals on the machine;
 - being transported by the machine;
 - using the machine to tow or push loads;
 - using the machine for leaf or debris collection;
 - using the machine to trim hedges, or for cutting vegetation other than grass;
 - use of the machine by more than one person;
 - using the blade on surfaces other than grass.
- Never allow children or people unfamiliar with these instructions to use the lawn mower. Local regulations can restrict the age of the operator.
- Never use the lawn mower:
 - when people, especially children, or pets are nearby;
 - if the operator has taken medicine or substances that can affect his ability to react and concentrate.
- Keep in mind that the operator or user is responsible for accidents or hazards occurring to other people or their property.
- The operators must receive proper training in the use, adjustment and operation of the machine, including prohibited operations.

Preparation

- While mowing, always wear substantial footwear and long trousers. Do not operate the equipment when barefoot or wearing open sandals.
- Thoroughly inspect the area where the equipment is to be used and remove all objects, such as stones, toys, sticks and wires, which can be thrown by the machine.
- **WARNING-** Petrol is highly flammable.
 - store fuel in containers specifically designed for this purpose;

- refuel outdoors only and do not smoke while refueling;
- add fuel before starting the engine. Never remove the cap of the fuel tank or add petrol while the engine is running or when the engine is hot;
- if petrol is spilled, do not attempt to start the engine but move the machine away from the area of spillage and avoid creating any source of ignition until petrol vapors have dissipated;
- replace all fuel tank and container caps securely.
- Replace faulty silencers.
- Before using, always visually inspect to see that the blades, blade bolts and cutter assembly are not worn or damaged. Replace worn or damaged blades and bolts in sets to preserve balance.
- Check regularly to ensure that all starting interlocks and operator presence controls are properly functioning.

Operation

- Do not operate the engine in a confined space where dangerous carbon monoxide fumes can collect.
- Do not use the machine while being tired, ill or under influence of alcohol or other drugs.
- **Warning!** Do not use the lawn mower when there is a risk for lighting.
- It is recommended to limit the duration of operation, in order to minimize the risks from noise and vibration.
- Be careful when using the lawn mower in slopes and near drop-offs, ditches or embankments.
- Mow only in daylight or in good artificial light.
- Avoid operating the equipment in wet grass, where feasible.
- Always be sure of your footing on slopes.
- Walk, never run.
- For wheeled rotary machines, mow across the face of slopes, never up and down.
- Exercise extreme caution when changing direction on slopes.
- Do not mow excessively steep slopes.
- Use extreme caution when reversing or pulling the lawn mower towards you.
- Stop the blade(s) if the lawn mower has to be tilted for transportation when crossing surfaces other than grass, and when transporting the lawn mower to and from the area to be mowed.
- Never operate the lawn mower with defective guards, or without safety devices, for example deflectors and/or grass catchers, in place.
- **Caution:** The lawn mower shall not be operated without either the entire grass catcher or self-closing discharge opening guard in place.
- Do not change the engine governor settings or overspend the engine.
- Do not alter or tamper with any sealed adjustment for the engine speed control.
- The lawn mower safety systems or features shall not be tampered with or disabled.
- Disengage all blade and drive clutches before starting the engine.
- Start the engine carefully according to instructions and with feet well away from the blade(s).
- Do not tilt the lawn mower when starting the engine.

- Do not start the engine when standing in front of the discharge chute.
- Do not put hands or feet near or under rotating parts. Keep clear of the discharge opening at all times.
- Never pick up or carry a lawn mower while the engine is running.
- Stop the engine and disconnect the spark plug wire, make sure that all moving parts have come to a complete stop and, where a key is fitted remove the key:
 - before clearing blockages or unclogging chute;
 - before checking, cleaning or working on the lawn mower;
 - after striking a foreign object. Inspect the lawn mower for damage and make repairs before restarting and operating the lawn mower;
 - if lawn mower starts to vibrate abnormally (check immediately).
- Stop the engine and disconnect the spark plug wire, make sure that all moving parts have come to a complete stop and, where a key is fitted remove the key:
 - whenever you leave the lawn mower;
 - before refueling.
- Reduce the throttle setting during engine shut down and, if the engine is provided with a shut-off valve, turn the fuel off at the conclusion of mowing.
- Only use the lawn mower for the purpose for which it is designed, for cutting and collecting grass. Any other use can be hazardous, causing damage to the machine.
- Check the grass catcher frequently for wear or deterioration.
- Replace worn or damaged parts for safety.
- If the fuel tank has to be drained, this should be done outdoors.
- Improper maintenance, use of non-conforming replacement components, or the removal or modification of safety components can damage the lawn mower and injure the operators seriously.
- Only use the recommended blades and spare parts by the manufacturer. The use of non-genuine parts can damage the machine and injure the operators. Keep the lawn mower in good working condition.
- If the blade stopping device doesn't work, please contact service center for help.

Transportation and handling

- Whenever the machine is to be handled, raised, transported or tilted you must:
 - wear strong working gloves;
 - grasp the machine at the points that offer a safe grip, taking account of the weight and its distribution;
 - use an appropriate number of people for the weight of the machine and the characteristics of the vehicle or the place where it has to be placed or collected.
- During transport, fasten the machine securely with ropes or chains.



WARNING: Do not touch rotating blade.



WARNING: Refuel in a well ventilated area with the engine stopped.

Maintenance and storage

- Keep all nuts, bolts and screws tight to be sure the equipment is in safe working condition.
- Never store the equipment with petrol in the tank inside a building where fumes can reach an open flame or spark.
- Allow the engine to cool before storing in any enclosure; Clean and maintain the lawn mower before storage.
- To reduce the fire hazard, keep the engine, silencer, battery compartment and petrol storage area free of grass, leaves, or excessive grease.

3. PARTS DESCRIPTION (Fig. 1 & 2)

Including

- A: Spark plug wrench
- B: Mulching wedge

4. TECHNICAL DATA

Model	PLM4120N	PLM4620N2
Engine type	B&S 500E Series	B&S 625E Series, ReadyStart
Self-Propelled	No	No
Engine Displacement	140 cm ³	150 cm ³
Nominal Power	1.9 kW	2.2 kW
Blade Width	410 mm	460 mm
Idle Speed	2,800/min	2,800/min
Fuel Tank Capacity	0.8L	0.8L
Oil tank capacity	0.47L	0.47L
Grass catcher capacity	50L	60L
Net Weight	26.0 kg	27.6 kg
Height adjustment	25 – 70 mm, 5 adjustment	25 – 70 mm, 5 adjustment

Model	PLM4120N	PLM4620N2
Guaranteed sound pressure level at operator's position (According to EN ISO 5395-1 Annex F & EN ISO 5395-2, EN ISO 4871)	84.6dB(A) (K=3dB(A))	82.0dB(A) (K=3dB(A))
Measured sound power level	93.4dB(A) K=1.93dB(A)	92.1dB(A) K=2.07dB(A)
Guaranteed sound power level (According to 2000/14/EC)	96dB(A)	96dB(A)
Vibration (According to EN ISO 5395-1 Annex G & EN ISO 5395-2)	4.75 m/s ² K=1.5 m/s ²	2.36 m/s ² K=1.5 m/s ²

5. ASSEMBLY

5-1 ASSEMBLING THE FOLDING HANDLE

- A) Fix the lower handlebars into the unit body with two sets of bolt, washer and locking knob as shown. (Fig. 3, Fig. 4, Fig. 5, Fig. 6)
- B) Release the upper handlebars for folding. Connect the upper handle and the lower handle with the two sets of bolt, washer and locking knob. (Fig. 7, Fig. 8, Fig. 9)
- C) Position all cables over the handle shafts. Clamp them around the middle of lower handles by the cable clamps so that the cables are fixed on the outside of the machine. Otherwise the cables may be pinched by opening/closing the rear cover or forced by folding the upper handle. (Fig. 10)

5-2 MOUNTING AND DISMOUNTING THE GRASS CATCHER

1. To fit: Lift the rear cover and hang the grass catcher on the shaft of rear of mower. (Fig. 11, Fig. 12)
2. To remove: Grasp and lift the rear cover, remove grass catcher.

5-3 STARTER HANDLE

Move the starter handle from the engine to the rope guide. (Fig. 13, Fig. 14)

5-4 HEIGHT OF CUT

Apply outward pressure to disengage lever from rack. Move lever forward or back to adjust height. (Fig. 15 and see clause 7-8)

5-5 ADJUSTMENT FOR AN APPROPRIATE HEIGHT

- 1) Back out the locking knob which fixed the lower handle. (Fig. 16)
- 2) Refer to Fig. 17, move the lower handle up and down, adjust it to the proper height.
There is 3 adjusting height to be chosen on this type lawn mower; at 1 height, lower handle to the ground is highest., 3 height is the lowest.
- 3) Adjusting to the proper height, then fix the lower handle by the locking knobs.



WARNING: The left side and right side of lower handle must adjust to the same height.

6. 2 IN 1

These lawn mowers can be retrofitted from its normal function, based on the application purpose:
From lawn mower with rear collection to mulching mower.
What is mulching?
When mulching, the grass is cut in one working step, then finely chopped and returned to the grass strip as natural fertilizer.

Hints for mulch-mowing:

- Regular cut-back by max. 2 cm from 6 cm to 4 cm grass height.
- Use a sharp cutting knife.
- Do not mow wet grass.
- Set max. engine speed.
- Only move at working pace.
- Regularly clean mulching wedge, housing inner side and mowing blade.

ONE: Retrofitting for mulching mower



WARNING: Only with a stopped engine and standstill cutter.

1. Raise the rear cover and remove the grass catcher.
2. Push the mulching wedge into the deck. Lock the mulching wedge with the button into the opening on the deck. (Fig. 18, Fig. 19)
3. Lower the rear cover again.

TWO: Mowing with the grass catcher

1. For mowing with the grass catcher, remove the mulching wedge and mount the grass catcher.
2. Removing the mulching wedge.
 - Lift rear cover and remove the mulching wedge.



WARNING: Only with a stopped engine and standstill cutter.

7. OPERATING INSTRUCTIONS

7-1 BEFORE STARTING

Service the engine with gasoline and oil as instructed in the separate engine manual packed in your mower. Read instructions carefully.



WARNING: Petrol is highly flammable.

Store fuel in containers specifically designed for this purpose.

Refuel outdoors only, before starting the engine and do not smoke while refueling or handling fuel.

Never remove the cap of the fuel tank or add petrol while the engine is running or when the engine is hot.

If petrol is spilled, do not attempt to start the engine but move the machine away from the area of spillage and avoid creating any source of ignition until petrol vapors have dissipated.

Replace all fuel tanks and container caps securely.

Before tipping the lawn mower to maintain the blade or drain oil, remove fuel from tank.



WARNING: Never fill fuel tank indoors, with engine running or until the engine has been allowed to cool for at least 15 minutes after running.

7-2 TO START ENGINE AND ENGAGE BLADE

1. The unit is equipped with a rubber boot over the end of the spark plug, make certain the metal loop on the end of the spark plug wire (inside the rubber boot) is fastened securely over the metal tip on the spark plug.
2. For PLM4120N:
When starting cool engine, press the primer bulb 3-5 times before starting the engine, turn throttle choke lever to “☁” position. When starting warm engine and operating, turn throttle choke lever to “☞” position. (Fig. 20, Fig. 21)
3. For PLM4620N2:
When starting cool or warm engine, turn throttle choke lever at anywhere between “☁” position and “☞” position. When operating, turn throttle choke lever to “☞” position. (Fig. 21)
4. Standing behind the unit, grasp the stop control handle and hold it against the upper handle as shown in Fig. 22.
5. Grasp the starter handle as shown Fig. 22 and pull it up rapidly. Return it slowly to the rope guide bolt after engine starts. Release the stop control handle to stop the engine and blade.



Start the engine carefully according to instructions and with feet well away from the blade.



Do not tilt the lawn mower when starting the engine. Start the mower on a level surface, free of high grass or obstacles.



Keep hands and feet away from the rotating parts. Do not start the engine when standing in front of the discharge opening.

7-3 OPERATION PROCEDURES

During operation, tightly hold the stop control handle with both hands.



Note: During operation, when the stop control handle is released, the engine will stop and thus stopping the lawn mower from operating.



WARNING! In order to avoid any unintentional start-ups of the lawn mower, it comes equipped with an engine brake which must be pulled back before the engine can be started. When the engine control lever is released it must return to its initial position, at which point the engine automatically switches off.



Note: Engine brake (brake handle): Use the lever to stop the engine. When you release the lever the engine and the blade stop automatically. To mow, hold the lever in the working position. Before you start to mow, check the start/stop lever several times to be sure that it is working properly. Ensure that the tension cable can be smoothly operated (i.e. is not catching or kinking in any way).

7-4 TO STOP ENGINE



CAUTION: The blade continues to rotate for a few seconds after the engine is shut off.

1. Release the stop control handle to stop the engine and blade.
2. Disconnect and ground the spark plug wire as instructed in the separate engine manual to prevent accidental starting while equipment is unattended.

7-5 FOR THE BEST RESULTS WHEN MOWING

Clear lawn of debris. Be sure that the lawn is clear of stones, sticks, wire or other foreign objects which could be accidentally thrown out by the mower in any direction and cause serious personal injury to the operator and others as well as damage to property and surrounding objects. Do not cut wet grass. For effective mowing do not cut wet grass because it tends to stick to the underside of the deck preventing proper mowing of the grass clippings. Cut no more than 1/3 the length of the grass.

The recommended cut for mowing is 1/3 the length of the grass. Ground speed will need to be adjusted so the clippings can be dispersed evenly into the lawn. For especially heavy cutting in thick grass it may be necessary to use one of the slowest speeds in order to get a clean well mowed cut. When mowing long grass you may have to cut the lawn in two passes, lowering the blade another 1/3 of the length for the second cut and perhaps cutting in a different pattern than was used the first time.

Overlapping the cut a little on each pass will also help to clean up any stray clippings left on the lawn. The mower should always be operated at full throttle to get the best cut and allow it to do the most effective job of mowing. Clean underside of deck.

Be certain to clean the underside of the cutting deck after each use to avoid a build-up of grass, which would prevent proper mulching.

Mowing leaves: The mowing of leaves can also be beneficial to your lawn. When mowing leaves make sure they are dry and are not laying too thick on the lawn. Do not wait for all the leaves to be off the trees before you mow.



WARNING: If you strike a foreign object, stop the engine. Remove wire from spark plug, thoroughly inspect the mower for any damage and repair the damage before restarting and operating the mower. Extensive vibration of the mower during operation is an indication of damage. The unit should be promptly inspected and repaired.

7-6 GRASS CATCHER

Empty and clean the bag, make sure it is clean and ensure its meshwork is ventilated. (Fig. 23)

7-7 DECK

The underside of the mower deck should be cleaned after each use to prevent a buildup of grass clippings, leaves, dirt or other matter. If this debris is allowed to accumulate, it will invite rust and corrosion, and may prevent proper mulching. The deck may be cleaned by tilting the mower and scraping clean with a suitable tool (make certain the spark plug wire is disconnected).

7-8 HEIGHT ADJUSTMENT INSTRUCTIONS



CAUTION: Do not at any time make any adjustment to lawn mower without first stopping the engine and disconnecting the spark plug wire.



CAUTION: Before changing mowing height, stop mower and disconnect spark plug cable. Your mower is equipped with a central height adjustment lever offering 5 height positions.

1. Stop mower and disconnect spark plug cable before changing mower cutting height.
2. The central height adjustment lever offers you 5 different height positions.
3. To change the height of cut, squeeze adjuster lever toward the wheel, moving up or down to selected height (Fig. 24). All wheels will be in the same height of cut.

8. MAINTENANCE INSTRUCTIONS

SPARK PLUG

Use only original replacement spark plug. For best results, replace the spark plug every 100 hours of use. (refer to ENGINE OWNER'S MANUAL)

BRAKE PADS

Check and/or replace the engine brake pads in service agent regularly, only original parts can be used as replacement.

9. LUBRICATION INSTRUCTIONS



CAUTION: DISCONNECT SPARK PLUG BEFORE SERVICING.

1. WHEELS-Lubricate the ball bearings in each wheel at least once a season with a light oil.
2. ENGINE-Follow engine manual for lubrication instructions.

10. CLEANING



CAUTION: Do not hose engine. Water can damage engine or contaminate the fuel system.

1. Wipe deck with dry cloth.
2. Hose under deck by tilting the mower so that the spark plug is up.

10-1 ENGINE AIR CLEANER



CAUTION: Do not allow dirt or dust to clog the air filter foam element.

The engine air cleaner element must be serviced (cleaned) after 25 hours normal mowing. The foam element must be serviced regularly if the mower is used in dry dusty conditions. (refer to ENGINE OWNER'S MANUAL)

To CLEAN AIR FILTER

1. Lift the tab on the filter cover. (Fig. 25A, Fig. 25B)
2. Remove the filter cover.
3. Wash filter element in soap water. **DO NOT USE GASOLINE!**
4. Air dry filter element.
5. Place a few drops of SAE30 oil on the foam filter and squeeze tightly to remove any excess oil.
6. Reinstall filter.
7. Close the filter cover.



NOTE: Replace filter if frayed, torn, damaged or unable to be cleaned.

10-2 CUTTING BLADE



CAUTION: Be sure to disconnect and ground the spark plug wire before working on the cutting blade to prevent accidental engine starting. Protect hands by using heavy gloves or a rag to grasp the cutting blades. Tip mower as specified in separate engine manual. Remove the hex bolt and washer which hold the blade and blade adapter to the engine crankshaft. Remove the blade and adapter from the crankshaft.



WARNING: Periodically inspect the blade adapter for cracks, especially if you strike a foreign object. Replace when necessary.

For best results your blade should be sharp. The blade may be resharpened by removing it and either grinding or filing the cutting edge keeping as close to the original bevel as possible. It is extremely important that each cutting edge receives an equal amount of grinding to prevent an unbalanced blade. Improper blade balance will result in excessive vibration causing eventual damage to the engine and mower. Be sure to carefully balance blade after sharpening. The blade can be tested for balance by balancing it on a round shaft screwdriver. Remove metal from the heavy side until it balances evenly. **(Fig. 26)** Before reassembling the blade and the blade adapter to the unit, lubricate the engine crankshaft and the inner surface of the blade adapter with light oil. Install the blade adapter on the crankshaft. Refer to **Fig. 26**. Place the blade with the part number facing away from the adapter. Align the washer over the blade and insert the hex bolt. Tighten the hex bolt to the torque listed below.

10-3 BLADE MOUNTING TORQUE

Center Bolt must be tightened to 35 - 45 Nm torque. To insure safe operation of your unit. ALL nuts and bolts must be checked periodically for correct tightness. After prolonged use, especially in sandy soil conditions, the blade will become worn and lose some of the original shape. Cutting efficiency will be reduced and the blade should be replaced.

Replace with an approved factory replacement blade only. Possible damage resulting from blade unbalance condition is not the responsibility of the manufacturer. When you change the blade, must use the original type marked on the blade (MAKITA 263001433 for PLM4120N; MAKITA 263001451 for PLM4620N2) (for order the blade, contact your local dealer or call our company).



WARNING: Do not touch rotating blade.

10-4 ENGINE

Refer to the separate engine manual for engine maintenance instructions.

Maintain engine oil as instructed in the separate engine manual packed with your unit.

Read and follow instructions carefully.

Service air cleaner as per separate engine manual under normal conditions. Clean every few hours under extremely dusty conditions. Poor engine performance and flooding usually indicates that the air cleaner should be serviced. To service the air cleaner, refer to the separate engine manual packed with your unit.

The spark plug should be cleaned and the gap reset once a season. Spark plug replacement is recommended at the start of each mowing season; check engine manual for correct plug type and gap specifications.

Clean the engine regularly with a cloth or brush. Keep the cooling system (blower housing area) clean to permit proper air circulation which is essential to engine performance and life. Be certain to remove all grass, dirt and combustible debris from muffler area.

11. STORAGE INSTRUCTIONS (OFF SEASON)

The following steps should be taken to prepare lawn mower for storage.

1. Empty the tank after the last mowing of the season.
 - a) Empty the petrol tank with a suction pump.



CAUTION: Do not drain the petrol in closed rooms, in close proximity of open fire, etc. Do not smoke! Petrol fumes can cause explosion or fire.

- b) Start the engine and let it run until it has used up all remaining petrol and stalls.
 - c) Remove the spark plug. Use an oilcan to fill approx. 20 ml oil into the combustion chamber. Operate the starter to evenly distribute the oil in the combustion chamber. Replace the spark plug.
2. Clean and grease the lawn mower carefully as described above under "LUBRICATION INSTRUCCIONES".
3. Slightly grease the cutter to avoid corrosion.
4. Store the lawn mower in a dry, clean and frost-protected place, out of reach of unauthorized persons.



CAUTION: The engine must have completely cooled down before storing the lawn mower.



NOTE:

When storing any type of power equipment in an unventilated or material storage shed;

- Care should be taken to rust-proof the equipment. Using a light oil or silicone, coat the equipment, especially cables and all moving parts.
- Be careful not to bend or kink cables.
- If the starter rope becomes disconnected from rope guide on handle, disconnect and ground the spark plug wire, depress the blade control handle and pull the starter rope out from engine slowly. Slip the starter rope into the rope guide bolt on handle.

Transport

Turn the engine off and allow the engine to cool down. Then disconnect the spark plug wire and empty the fuel tank according to the instructions in the engine manual. Ensure not to bend or damage the cutter when pushing the lawn mower over obstacles.

12. TROUBLESHOOTING

PROBLEM	PROBABLE CAUSE	CORRECTIVE ACTION
Engine does not start.	Throttle choke not in the correct position for the prevailing conditions.	Move throttle choke to correct position.
	Fuel tank is empty.	Fill tank with fuel: refer to ENGINE OWNER'S MANUAL.
	Air cleaner element is dirty.	Clean air cleaner element: refer to ENGINE OWNER'S MANUAL.
	Spark plug loose.	Tighten spark plug to 25 - 30 Nm.
	Spark plug wire loose or disconnected from plug.	Install spark plug wire on spark plug.
	Spark plug gap is incorrect.	Set gap between electrodes at 0.7 to 0.8 mm.
	Spark plug is defective.	Install new, correctly gapped plug: refer to ENGINE OWNER'S MANUAL.
	Carburetor is flooded with fuel.	Remove air cleaner element and pull starter rope continuously until carburetor clears itself and install air cleaner element.
Engine difficult to start or loses power.	Faulty ignition module.	Contact Makita authorised service centre.
	Dirt, water, or stale fuel tank.	Drain fuel and clean tank. Fill tank with clean, fresh fuel.
	Vent hole in fuel tank cap is plugged.	Clean or replace fuel tank cap.
Engine operates erratically.	Air cleaner element is dirty.	Clean air cleaner element.
	Spark plug is defective.	Install new, correctly gapped plug: refer to ENGINE OWNER'S MANUAL.
	Spark plug gap is incorrect.	Set gap between electrodes at 0.7 to 0.8 mm.
Engine idles poorly.	Air cleaner element is dirty.	Clean air cleaner element: refer to ENGINE OWNER'S MANUAL.
	Air slots in engine shroud are blocked.	Remove debris from slots.
	Cooling fins and air passages under engine blower housing are blocked.	Remove debris from cooling fins and air passages.
Engine skips at high speed.	Gap between electrodes of spark plug is too close.	Set gap between electrodes at 0.7 to 0.8 mm.
Engine overheats.	Cooling air flow is restricted.	Remove any debris from slots in shroud, blower housing, air passages.
	Incorrect spark plug.	Install original spark plug and cooling fins on engine.
Mower vibrates abnormally.	Cutting assembly is loose.	Tighten blade.
	Cutting assembly is unbalanced.	Balance blade.

13. ENVIRONMENT

Should your machine need replacement after extended use, do not put it in the domestic waste but dispose of it in an environmentally safe way.

14. EC DECLARATION OF CONFORMITY

For European countries only

The EC declaration of conformity is included as Annex A to this instruction manual.

Makita Europe N.V. Jan-Baptist Vinkstraat 2,
3070 Kortenberg, Belgium

Makita Corporation 3-11-8, Sumiyoshi-cho,
Anjo, Aichi 446-8502 Japan