

INSTRUCTION MANUAL

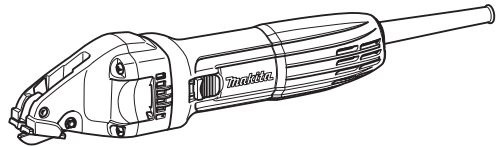

# Metal Shear/ Straight Metal Shear

**JS1000**  
**JS1601**



DOUBLE INSULATION



Read before use.

# SPECIFICATIONS

| Model                                   |                                      | JS1000         | JS1601         |
|---|--------------------------------------|----------------|----------------|
| Max. cutting capacities                 | Steel up to 400 N/mm <sup>2</sup>    | 1.0 mm (20 ga) | 1.6 mm (16 ga) |
|   | Steel up to 600 N/mm <sup>2</sup>    | 0.7 mm (23 ga) | 1.2 mm (18 ga) |
|   | Steel up to 800 N/mm <sup>2</sup>    | 0.5 mm (26 ga) | 0.8 mm (21 ga) |
|   | Aluminum up to 200 N/mm <sup>2</sup> | 2.5 mm (12 ga) | 2.5 mm (12 ga) |
| Min. cutting radius                     |                                      | 30 mm          | 250 mm         |
| Strokes per minute (min <sup>-1</sup> ) |                                      | 4,500          |                |
| Overall length                          |                                      | 322 mm         | 320 mm         |
| Net weight                              |                                      | 1.4 kg         |                |
| Safety class                            |                                      | □/II           |                |

- Due to our continuing program of research and development, the specifications herein are subject to change without notice.
- Specifications may differ from country to country.
- Weight according to EPTA-Procedure 01/2014

## Symbols

The followings show the symbols used for the equipment. Be sure that you understand their meaning before use.



Read instruction manual.



DOUBLE INSULATION



Only for EU countries  
Do not dispose of electric equipment together with household waste material! In observance of the European Directive, on Waste Electric and Electronic Equipment and its implementation in accordance with national law, electric equipment that have reached the end of their life must be collected separately and returned to an environmentally compatible recycling facility.

## Intended use

The tool is intended for cutting sheet steel and stainless sheet steel.

## Power supply

The tool should be connected only to a power supply of the same voltage as indicated on the nameplate, and can only be operated on single-phase AC supply. They are double-insulated and can, therefore, also be used from sockets without earth wire.

## Noise

The typical A-weighted noise level determined according to EN62841-2-8:

Sound pressure level ( $L_{pA}$ ) : 77 dB(A)

Uncertainty (K) : 3 dB(A)

The noise level under working may exceed 80 dB (A).

**NOTE:** The declared noise emission value(s) has been measured in accordance with a standard test method and may be used for comparing one tool with another.

**NOTE:** The declared noise emission value(s) may also be used in a preliminary assessment of exposure.

**⚠ WARNING:** Wear ear protection.

**⚠ WARNING:** The noise emission during actual use of the power tool can differ from the declared value(s) depending on the ways in which the tool is used especially what kind of workpiece is processed.

**⚠ WARNING:** Be sure to identify safety measures to protect the operator that are based on an estimation of exposure in the actual conditions of use (taking account of all parts of the operating cycle such as the times when the tool is switched off and when it is running idle in addition to the trigger time).

## Vibration

The vibration total value (tri-axial vector sum) determined according to EN62841-2-8:

Work mode: cutting sheet metal

Vibration emission ( $a_{h,M}$ ) : 9.5 m/s<sup>2</sup>

Uncertainty (K) : 1.5 m/s<sup>2</sup>

**NOTE:** The declared vibration total value(s) has been measured in accordance with a standard test method and may be used for comparing one tool with another.

**NOTE:** The declared vibration total value(s) may also be used in a preliminary assessment of exposure.

**⚠️WARNING:** The vibration emission during actual use of the power tool can differ from the declared value(s) depending on the ways in which the tool is used especially what kind of workpiece is processed.

**⚠️WARNING:** Be sure to identify safety measures to protect the operator that are based on an estimation of exposure in the actual conditions of use (taking account of all parts of the operating cycle such as the times when the tool is switched off and when it is running idle in addition to the trigger time).

## EC Declaration of Conformity

### For European countries only

The EC declaration of conformity is included as Annex A to this instruction manual.

## General power tool safety warnings

**⚠️WARNING:** Read all safety warnings, instructions, illustrations and specifications provided with this power tool. Failure to follow all instructions listed below may result in electric shock, fire and/or serious injury.

## Save all warnings and instructions for future reference.

The term "power tool" in the warnings refers to your mains-operated (corded) power tool or battery-operated (cordless) power tool.

### Work area safety

1. **Keep work area clean and well lit.** Cluttered or dark areas invite accidents.
2. **Do not operate power tools in explosive atmospheres, such as in the presence of flammable liquids, gases or dust.** Power tools create sparks which may ignite the dust or fumes.
3. **Keep children and bystanders away while operating a power tool.** Distractions can cause you to lose control.

### Electrical safety

1. **Power tool plugs must match the outlet. Never modify the plug in any way. Do not use any adapter plugs with earthed (grounded) power tools.** Unmodified plugs and matching outlets will reduce risk of electric shock.
2. **Avoid body contact with earthed or grounded surfaces, such as pipes, radiators, ranges and refrigerators.** There is an increased risk of electric shock if your body is earthed or grounded.
3. **Do not expose power tools to rain or wet conditions.** Water entering a power tool will increase the risk of electric shock.
4. **Do not abuse the cord. Never use the cord for carrying, pulling or unplugging the power tool. Keep cord away from heat, oil, sharp edges or moving parts.** Damaged or entangled cords increase the risk of electric shock.

5. **When operating a power tool outdoors, use an extension cord suitable for outdoor use.** Use of a cord suitable for outdoor use reduces the risk of electric shock.
6. **If operating a power tool in a damp location is unavoidable, use a residual current device (RCD) protected supply.** Use of an RCD reduces the risk of electric shock.
7. **Use of power supply via an RCD with a rated residual current of 30 mA or less is always recommended.**
8. **Power tools can produce electromagnetic fields (EMF) that are not harmful to the user.** However, users of pacemakers and other similar medical devices should contact the maker of their device and/or doctor for advice before operating this power tool.
9. **Do not touch the power plug with wet hands.**
10. **If the cord is damaged, have it replaced by the manufacturer or his agent in order to avoid a safety hazard.**

### Personal safety

1. **Stay alert, watch what you are doing and use common sense when operating a power tool. Do not use a power tool while you are tired or under the influence of drugs, alcohol or medication.** A moment of inattention while operating power tools may result in serious personal injury.
2. **Use personal protective equipment. Always wear eye protection.** Protective equipment such as a dust mask, non-skid safety shoes, hard hat or hearing protection used for appropriate conditions will reduce personal injuries.
3. **Prevent unintentional starting. Ensure the switch is in the off-position before connecting to power source and/or battery pack, picking up or carrying the tool.** Carrying power tools with your finger on the switch or energising power tools that have the switch on invites accidents.
4. **Remove any adjusting key or wrench before turning the power tool on.** A wrench or a key left attached to a rotating part of the power tool may result in personal injury.
5. **Do not overreach. Keep proper footing and balance at all times.** This enables better control of the power tool in unexpected situations.
6. **Dress properly. Do not wear loose clothing or jewellery. Keep your hair and clothing away from moving parts.** Loose clothes, jewellery or long hair can be caught in moving parts.
7. **If devices are provided for the connection of dust extraction and collection facilities, ensure these are connected and properly used.** Use of dust collection can reduce dust-related hazards.
8. **Do not let familiarity gained from frequent use of tools allow you to become complacent and ignore tool safety principles.** A careless action can cause severe injury within a fraction of a second.
9. **Always wear protective goggles to protect your eyes from injury when using power tools. The goggles must comply with ANSI Z87.1 in the USA, EN 166 in Europe, or AS/NZS 1336 in Australia/New Zealand. In Australia/New Zealand, it is legally required to wear a face shield to protect your face, too.**



It is an employer's responsibility to enforce the use of appropriate safety protective equipments by the tool operators and by other persons in the immediate working area.

#### Power tool use and care

1. **Do not force the power tool. Use the correct power tool for your application.** The correct power tool will do the job better and safer at the rate for which it was designed.
2. **Do not use the power tool if the switch does not turn it on and off.** Any power tool that cannot be controlled with the switch is dangerous and must be repaired.
3. **Disconnect the plug from the power source and/or remove the battery pack, if detachable, from the power tool before making any adjustments, changing accessories, or storing power tools.** Such preventive safety measures reduce the risk of starting the power tool accidentally.
4. **Store idle power tools out of the reach of children and do not allow persons unfamiliar with the power tool or these instructions to operate the power tool.** Power tools are dangerous in the hands of untrained users.
5. **Maintain power tools and accessories. Check for misalignment or binding of moving parts, breakage of parts and any other condition that may affect the power tool's operation. If damaged, have the power tool repaired before use.** Many accidents are caused by poorly maintained power tools.
6. **Keep cutting tools sharp and clean.** Properly maintained cutting tools with sharp cutting edges are less likely to bind and are easier to control.
7. **Use the power tool, accessories and tool bits etc. in accordance with these instructions, taking into account the working conditions and the work to be performed.** Use of the power tool for operations different from those intended could result in a hazardous situation.
8. **Keep handles and grasping surfaces dry, clean and free from oil and grease.** Slippery handles and grasping surfaces do not allow for safe handling and control of the tool in unexpected situations.
9. **When using the tool, do not wear cloth work gloves which may be entangled.** The entanglement of cloth work gloves in the moving parts may result in personal injury.

#### Service

1. **Have your power tool serviced by a qualified repair person using only identical replacement parts.** This will ensure that the safety of the power tool is maintained.
2. **Follow instruction for lubricating and changing accessories.**

### SHEAR SAFETY WARNINGS

1. **Hold the tool firmly.**
2. **Secure the workpiece firmly.**
3. **Keep hands away from moving parts.**
4. **Edges and chips of the workpiece are sharp. Wear gloves.** It is also recommended that you put on thickly bottomed shoes to prevent injury.
5. **Do not put the tool on the chips of the workpiece. Otherwise it can cause damage and trouble on the tool.**
6. **Do not leave the tool running. Operate the tool only when hand-held.**
7. **Always be sure you have a firm footing. Be sure no one is below when using the tool in high locations.**
8. **Do not touch the blade or the workpiece immediately after operation; they may be extremely hot and could burn your skin.**
9. **Avoid cutting electrical wires. It can cause serious accident by electric shock.**
10. **Do not operate the tool at no-load unnecessarily.**

### SAVE THESE INSTRUCTIONS.

**⚠WARNING: DO NOT let comfort or familiarity with product (gained from repeated use) replace strict adherence to safety rules for the subject product. MISUSE or failure to follow the safety rules stated in this instruction manual may cause serious personal injury.**

# FUNCTIONAL DESCRIPTION

## ⚠ CAUTION:

- Always be sure that the tool is switched off and unplugged before adjusting or checking function on the tool.

## Switch action

## ⚠ CAUTION:

- Before plugging in the tool, always check to see that the switch lever actuates properly and returns to the "OFF" position when the rear of the switch lever is depressed.
- Switch can be locked in "ON" position for ease of operator comfort during extended use. Apply caution when locking tool in "ON" position and maintain firm grasp on tool.

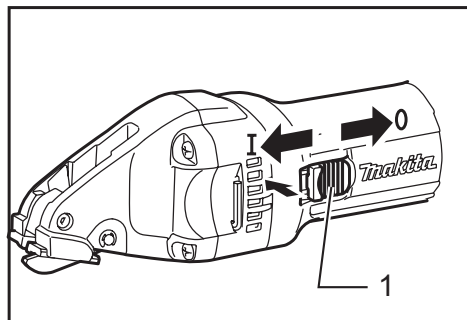

► 1. Switch lever

To start the tool, slide the switch lever toward the "I (ON)" position. For continuous operation, press the front of the switch lever to lock it.

To stop the tool, press the rear of the switch lever, then slide it toward the "O (OFF)" position.

# ASSEMBLY

## ⚠ CAUTION:

- Always be sure that the tool is switched off and unplugged before carrying out any work on the tool.

## Adjusting the blade clearance

### For JS1601 Only

Adjust the clearance between the side blade and the center blade according to the thickness of the workpiece.

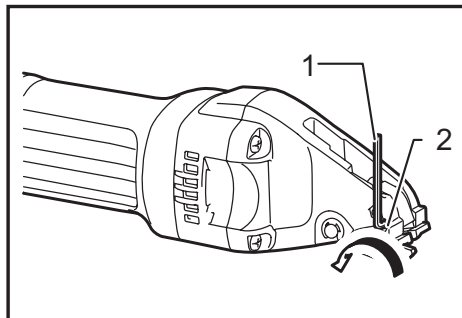

► 1. Hex wrench 2. Screw

First use a hex wrench to loosen the screw.

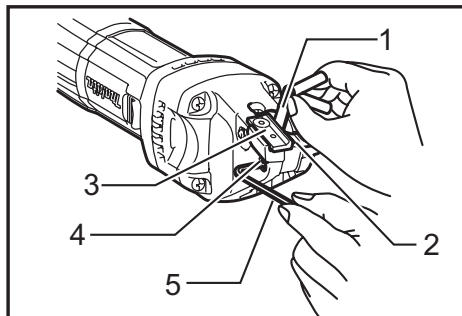

► 1. Thickness gauge 2. Center blade 3. Side blade 4. Hex socket head bolt 5. Hex wrench

Then use the hex wrench to adjust the clearance by tightening or loosening the bolt. There may be a slight difference between clearances of both sides of the center blade.

Check the smaller clearance with the thickness gauge and adjust it.

When using the thickness gauge to adjust the blade clearance, refer to the table.

| Workpiece thickness (mm) | Marking on thickness gauge |
|--------------------------|----------------------------|
| Less than 0.8            | 0.5                        |
| 0.8 - 1.3                | 1.0                        |
| More than 1.3            | 1.5                        |

After adjusting the clearance, tighten the screw securely.

## Storing hex wrench

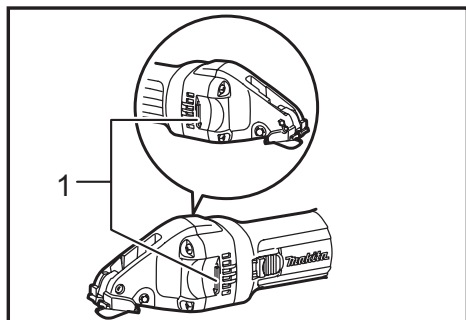

► 1. Hex wrench

Store the hex wrench as shown in the figure when not in use.

## OPERATION

### Lubrication

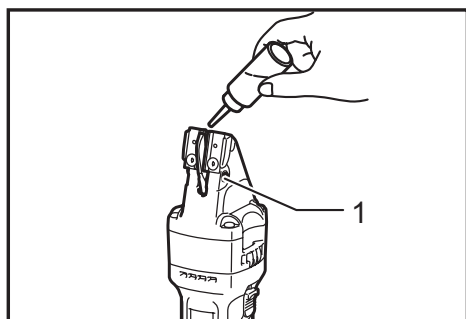

► 1. Pin

Before operation, lubricate the contact point of the center blade and the pin. To keep good cutting performance, also use a cutting lubricant from time to time during operation.

### OPERATION

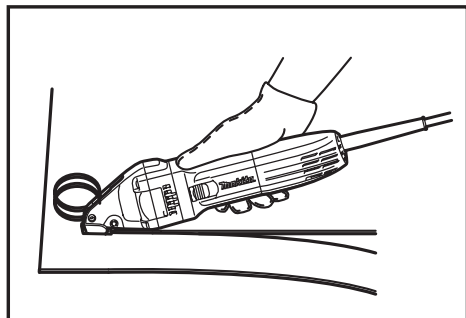

Always hold the tool firmly with one hand on housing. Do not touch the metal part.

Turn the tool on and set front ends of the side blades on the workpiece. Now simply move the tool forward, keeping the side blades flush with the workpiece surface.

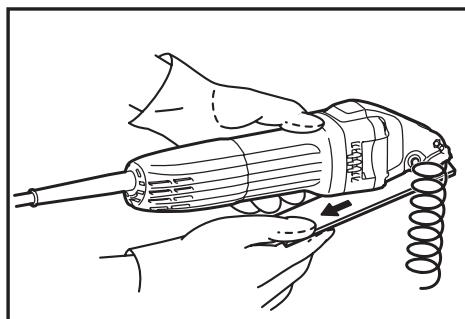

### NOTE:

- When cutting a small portion of the workpiece, you may have difficulty completing the end of the cut. In that case, try to cut it again, pulling the workpiece back slightly.

## MAINTENANCE

### ⚠ CAUTION:

- Always be sure that the tool is switched off and unplugged before attempting to perform inspection or maintenance.
- Never use gasoline, benzine, thinner, alcohol or the like. Discoloration, deformation or cracks may result.

To maintain product SAFETY and RELIABILITY, repairs, any other maintenance or adjustment should be performed by Makita Authorized Service Centers, always using Makita replacement parts.

## OPTIONAL ACCESSORIES

### ⚠ CAUTION:

- These accessories or attachments are recommended for use with your Makita tool specified in this manual. The use of any other accessories or attachments might present a risk of injury to persons. Only use accessory or attachment for its stated purpose.

If you need any assistance for more details regarding these accessories, ask your local Makita Service Center.

- Center blade
- Side blade R
- Side blade L
- Hex wrench
- Thickness gauge

**NOTE:** Some items in the list may be included in the tool package as standard accessories. They may differ from country to country.



**Makita Europe N.V.** Jan-Baptist Vinkstraat 2,  
3070 Kortenberg, Belgium

**Makita Corporation** 3-11-8, Sumiyoshi-cho,  
Anjo, Aichi 446-8502 Japan

[www.makita.com](http://www.makita.com)

|                              |
|------------------------------|
| 884959A223<br>EN<br>20190321 |
|------------------------------|