

## Operating Instructions

To operate the Makita Model HG 1100 Thermocouple Heat Gun plug the cord into a 120 V.A.C. power source. Be sure the power switch is in the OFF position.

The HG 1100 has a three position power switch as shown in FIGURE 1. Be sure the unit is pointed away from yourself and materials when turning the unit on. In addition to turning the power on to the unit, the switch also controls the speed of the blower. Select the desired blower speed by positioning the switch with the forefinger.

The next step is to adjust the temperature to the desired setting by turning the thumb wheel which is located in the rear cap of the unit. Move the thumb wheel in a clockwise motion for a higher temperature and a counter clockwise motion for a lower temperature. The temperature range is adjustable from 250° F to 1100° F.

The tool may be used in a hand held position or in a hands free upright position on a flat level surface. When using the unit in the upright position, be sure the cord is placed in such a position that it will prevent tipping the heat gun over, pulling the heat gun off the work surface or causing tripping over the cord.

## Important Safety Instructions

### WARNING:

Hidden areas such as behind walls, ceilings, floors, soffit boards, and other panels **may contain flammable materials that could be ignited by the heat gun** when working in these locations. The ignition of these materials may not be readily apparent and could result in property damage and injury to persons. Do not use if in doubt about this hazard.

When working in these locations, keep the heat gun moving in a back-and-forth motion. Lingering or pausing in one spot could ignite the panel or the material behind it. The heat gun should be used on LOW temperature.

## Paint Stripping

Extra care should be taken when stripping paint. The peelings, residue and vapors of **paint may contain lead, which is poisonous**. Any pre-1977 may contain lead and paint applied to homes prior to 1950 is likely to contain lead. The peelings and residue can be ground into floors and enter the air by normal cleaning methods such as sweeping or vacuuming. Once deposited on surfaces, hand-to-mouth contact can result in the ingestion of lead. Exposure to even low levels of lead can cause irreversible brain and nervous system damage; young and unborn children are particularly vulnerable.

Before beginning any paint removal process you should determine whether the paint you are removing contains lead. This can be done by your local health department or by a professional who used a paint analyzer to check the lead content of the paint to be removed. **Lead-based paint should be only be removed by a professional and should not be removed using a heat gun.** Paint stripping should only be performed with adequate ventilation, such as a fan (in the exhaust mode) or by moving the work-piece outdoors where possible.

It is recommended that you use a particle mask when stripping paint.

Failure to adhere to these precautions could result in the **inhalation and ingestion of lead** which could be hazardous to your health.

## Persons removing paint should follow these guidelines

1. Move the work piece outdoors. If this is not possible, keep the work area well ventilated. Open the windows and put an exhaust fan in one of them. Be sure the fan is moving the air from inside to outside.
2. Remove or cover any carpets, rugs, furniture, clothing, cooking utensils and air ducts.
3. Place drop cloths in the work area to catch any paint chips or peelings. Wear protective clothing such as extra work shirts, overalls and hats.
4. Work in one room at a time. Furnishings should be removed or placed in the center of the room and covered. Work areas should be sealed off from the rest of the dwelling by sealing doorways with drop cloths.
5. Children, pregnant or potentially pregnant women and nursing mothers, should not be present in the work area until the work is done and all clean up is complete.
6. Wear a dust respirator mask or a dual filter (dust and fume) respirator mask which has been approved by the Occupational Safety and Health Administration (OSHA), the National Institute of Safety and Health (NIOSH), or the United States Bureau of Mines. These masks and replaceable filters are readily available at major hardware stores. Be sure the mask fits. Beards and facial hair may keep masks from sealing properly. Change filters often. **Disposable paper masks are not adequate.**
7. Use caution when operating the heat gun. Keep the heat gun moving as excessive heat will generate fumes which can be inhaled by the operator.
8. Keep food and drink out of the work area. Wash hands, arms and face and rinse mouth before eating or drinking. Do not smoke or chew gum or tobacco in the work area.
9. Clean up all removed paint and dust by wet mopping the floors. Use a wet cloth to clean all walls, sills and any other surface where paint or dust is clinging. **Do not sweep, dry dust or vacuum.** Use a high phosphate detergent or trisodium phosphate (TSP) to wash and mop areas.
10. At the end of each work session put the paint chips and debris in a double plastic bag, close it with tape or twist ties, and dispose of properly.
11. Remove protective clothing and work shoes in the work area to avoid carrying dust into the rest of the dwelling. Wash work clothes separately. Wipe shoes off with a wet rag that is then washed with the work clothes. Wash hair and body thoroughly with soap and water.

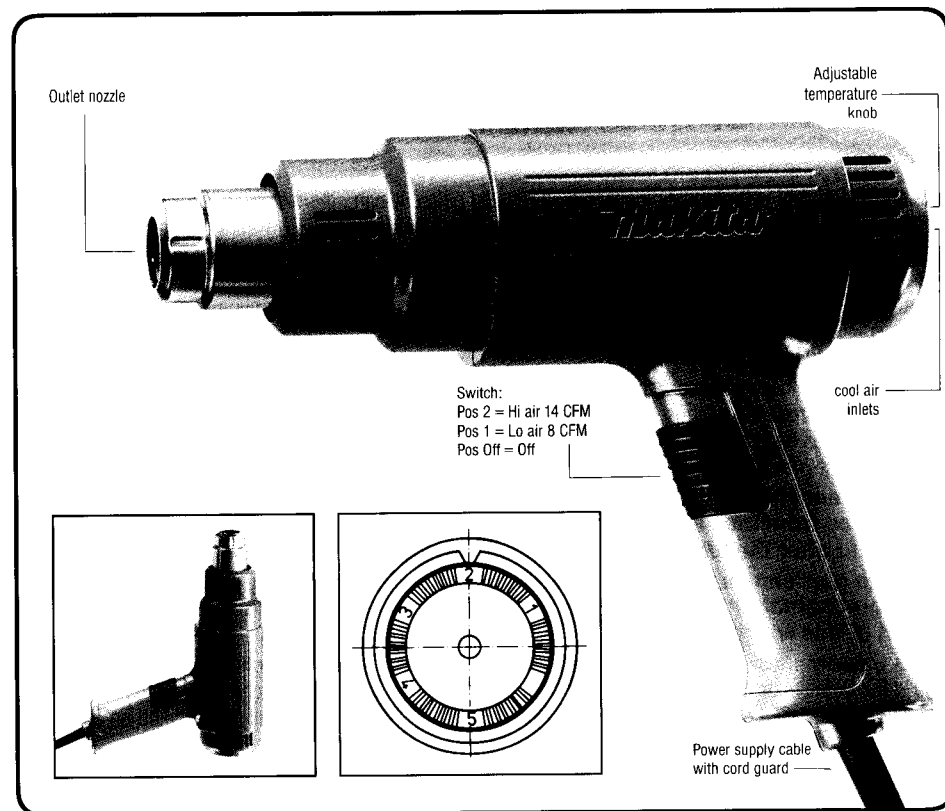

### Technical data HG 1100

|                 |  |
|-----------------|--|
| Temperature:    | Variable adjustment<br>250° F – 1100 ° F |
| Watts:          | 200 – 1500 watts                         |
| Amps:           | 12.5                                     |
| Supply voltage: | 120 VAC                                  |
| Air Flows:      | Lo 8 CFM<br>Hi 14 CFM                    |

### Features

- Balanced, lightweight design.
- High-impact plastic housing for lasting durability
- Heating element is ceramic encapsulated for durability and longer life
- Heat time is just 50 seconds
- No "cool down" cycle required
- Variable temperature adjustment
- Two speed airblower

# Makita

## Thermocouple Heat Gun

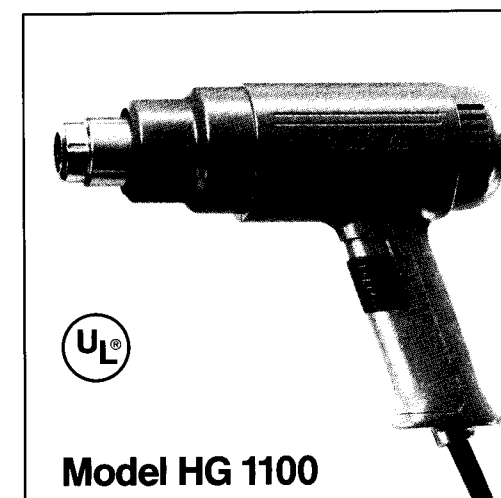

# Operator's Use & Care Manual

## Makita Limited One Year Warranty Warranty Policy

Every Makita tool is thoroughly inspected and tested before leaving the factory. It is warranted to be free of defects from workmanship and materials for the period of ONE YEAR from the date of original purchase. Should any trouble develop during this one-year-period, return the COMPLETE tool, freight prepaid, to one of Makita's Factory or Authorized Service Centers. If inspection shows the trouble is caused by defective workmanship or material, Makita will repair (or, at our option, replace) without charge.

This Warranty does not apply where:

- repairs have been made or attempted by others
- repairs are required because of normal wear and tear
- the tool has been abused, misused or improperly maintained
- alterations have been made to the tool

**In no event shall Makita be liable for any indirect, incidental or consequential damages from the sale or use of the product. This disclaimer applies both during and after the term of warranty.**

**Makita disclaims liability for any implied warranties, including implied warranties of "merchantability" and "fitness for a specific purpose", after the one-year term of this warranty.**

This warranty gives you specific legal rights, and you may also have other rights which vary from state to state. Some states do not allow the exclusion or limitation of incidental or consequential damages, so the above limitation or exclusion may not apply to you. Some states do not allow limitation on how long an implied warranty lasts, so the above limitation may not apply to you.

**WARNING** Read this instruction manual before using. To reduce risk of fire or electrical shock do not expose to rain or moisture. Store indoors. When servicing, use only identical replacement parts. When using electrical tools, basic safety precautions should always be followed to reduce the risk of fire, electrical shock and personal injury. This Heat Gun operates at 1100° F with no visual indication of temperature (no flame). The hot airstream at the outlet nozzle will burn flesh. Do not turn on Heat Gun with hand in front of nozzle.  
**DO NOT USE NEAR COMBUSTIBLE LIQUIDS. DO NOT USE FOR:** Heating gas engines - Heating car batteries - Thawing refrigeration equipment.

**Remember!** This tool is capable of producing temperatures up to 1100° F of flameless heat:

- Direct the heat away from yourself and others.
- Prevent ignition of combustible materials on or near the workpiece.
- Prevent blockage of intake and nozzle openings.
- Keep a fully charged fire extinguisher on hand.
- Allow the nozzle and accessory tips to cool to room temperature before storage.

### Cautions

1. This heat gun can produce up to 1100° F of flameless heat at the nozzle. Do not direct air stream at clothing, hair, or other body parts. Do not use as a hair dryer.

2. Do not use near flammable liquids or in an explosive environment (fumes, gases or dust). Remove materials or debris that may become ignited, from work area.
3. Always hold tool by plastic enclosure. The metal nozzle requires approximately 20 minutes to cool to where it can be touched. Do not touch nozzle or accessory tips until cool.
4. Do not store tool until nozzle has cooled to room temperature. Place tool in a clear area away from combustible materials while cooling. Store indoors.
5. Do not cut off air flow. Keep cool air inlets clean and clear of obstructions.
6. Place tool on a level surface when tool is not hand held. Place cord in a position that won't cause tipping, or tripping.
7. Do not leave tool unattended while running or cooling down.
8. Keep a fully charged fire extinguisher nearby.
9. Do not direct air flow directly on glass.
10. Shield materials around the heated area to prevent damage or fire.
11. Use only with 120 Volts A.C.
12. Do not use in wet conditions.
13. The voltage from the power source must match that specified on the nameplate.
14. Not to be used by children. This is not a toy and must be respected.
15. Do not use in bath or near water.
16. Safety glasses complying with current national standards should be worn when using this tool.
17. For stripping paint see detailed instructions in this manual.
18. It is recommended that gloves be worn when using a Heat Gun.

### Extension Cords

Double insulated tools, like this one, have two prong cords, and can use either a two or three prong extension cord. As the distance from the supply outlet increases, however, heavier gauge extension cords are required. The use of extension cords of inadequate size wire causes a serious drop in voltage and loss of power. Protect the cord from damage. Keep cords away from excessive heat, sharp edges and damp or wet areas. Repair or replace damaged extension cords before using.

| Ext Cord Lgth. | Wire Size |
|----------------|-----------|
| 40 Ft.         | 16        |
| 65 Ft.         | 14        |
| 100 Ft.        | 12        |
| 170 Ft.        | 10        |
| 270 Ft.        | 8         |
| 400 Ft.        | 6         |
| 650 Ft.        | 4         |

### Hints on uses for the Makita HG 1100 Thermocouple Heat Gun

#### Forming and shaping plastic materials

- Soften PVC pipe and other plastic materials for bending and shaping
- Soften Vinyl Floor coverings and around mouldings.
- Soften, plastic laminate coverings for shaping rounded bends on countertops

#### Welding plastic materials

(Caution: When attempting plastic welding, experiment on scrap material beforehand.)

- Welding plastic parts on automobiles
- Welding leaking PVC plumbing pipes and joints
- Lap-welding PVC sheet materials
- Repairing household items made of PVC and welding PVC flooring materials
- Repairing sprinkler system PVC pipes (Detailed instructions for plastic welding are on the Makita welding rod packages.)

#### Roofing

- Heat welding of single ply roofing membranes
- Heating roofing tar and roofing cement

#### Glueing and removal of adhesives

- Activating heat sensitive adhesives
- Removal of stickers from automobile bumpers and windows
- Softening and removal of adhesives

#### Soldering

- Soldering and desoldering copper pipe up to 3/4"
- De-soldering components on PC boards
- Activate solder and wire connectors

#### Drying

- Drying paint samples
- Drying plaster filling compounds

#### Shrinking

- Shrinking tube insulators
- Heat shrink packaging wrap

#### Thawing

- Thaw frozen water pipes
- Thaw frozen locks

#### Other uses

- Speed setting of fiberglass fillers
- Wax removal on skies and surfboards
- Apply hot patches
- Paint stripping
- Softening hardened window glazing

### Heat Gun Nozzles

#### For Specific Tasks

**WARNING:** Always unplug the tool before attaching or removing accessories. Do not remove accessory tips until the tool has cooled to room temperature.

### Nozzle Descriptions

#### Plastic Welding Nozzle

Attached to Item No. 110706-A to provide concentrated air flow to melt the plastic welding rod. Also, can be used for fusing plastic parts together  
Item No. 110720-A



#### Plastic Welding Rods

Used to provide filler material for welding operation. Caution: be sure welding rod material matches material being welded. Rods are approx 9" long and 1/8" in dia. with 16 pcs. per package.

**PVC plastic**  
item No. 110731-A  
**ABS plastic**  
item No. 110742-A

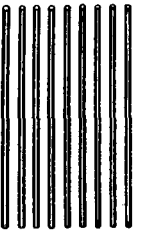

#### 3/8" Reduction Nozzle

Provides small area air flow (approx 3/8"). Also, used with Item No. 110720-A for plastic welding.  
Item No. 110706-A



#### 3/8" Reflector Nozzle

Small reflector nozzle for use in activating solder sink wire connectors and small shrink tubing.  
Item No. 110746-A



#### Wide Angle Slit Nozzle

Provides a 1 3/4" x 3/16" air flow. Nozzle has a slight angle to direct air flow for lap welding surfaces such as PVC materials and single ply roofing.  
Item No. 110751-A



#### 3" Surface Nozzle

Provides a 3" by 1/4" air flow for heating large surfaces.  
Item No. 110702-A



#### Large Reflector Nozzle

3" Wide. Used to deflect air flow around pipes. Used for bending PVC pipe, heat shrinking tubing, thawing pipe and soldering copper pipe.  
Item No. 110730-A



**Available at your Makita dealer**