

INSTRUCTION MANUAL

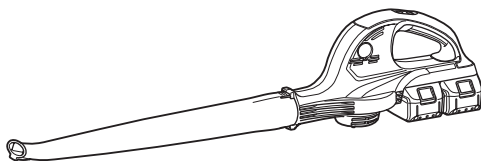

Cordless Blower

DUB361



Read before use.

SPECIFICATIONS

Model		DUB361
Capacities	Air volume (HIGH)	4.4 m ³ /min
	Air volume (LOW)	2.6 m ³ /min
No load speed (min ⁻¹)	HIGH	17,000
	LOW	10,000
Overall length	(without long nozzle)	420 mm
	(with long nozzle)	905 mm
Net weight		3.1 - 3.2 kg
Battery cartridge		BL1815N, BL1820, BL1820B, BL1830, BL1840, BL1850, BL1830B, BL1840B, BL1850B, BL1860B
Rated voltage		D.C. 36 V

- Due to our continuing program of research and development, the specifications herein are subject to change without notice.
- Specifications and battery cartridge may differ from country to country.
- The weight may differ depending on the attachment(s), including the battery cartridge. The lightest and heaviest combination, according to EPTA-Procedure 01/2014, are shown in the table.

Symbols

The following show the symbols used for the equipment. Be sure that you understand their meaning before use.

	Take particular care and attention.
	Read instruction manual.
	Keep a hand away from rotating parts.
	Keep bystanders away.
	Wear eye and ear protection.
	Do not expose to moisture.
 Cd Ni-MH Li-ion	Only for EU countries Do not dispose of electric equipment or battery pack together with household waste material! In observance of the European Directives, on Waste Electric and Electronic Equipment and Batteries and Accumulators and Waste Batteries and Accumulators and their implementation in accordance with national laws, electric equipment and batteries and battery pack(s) that have reached the end of their life must be collected separately and returned to an environmentally compatible recycling facility.

Intended use

The tool is intended for blowing dust.

CORDLESS BLOWER SAFETY WARNINGS

Training

1. Read the instructions carefully. Be familiar with the controls and the correct use of the blower.
2. Never allow children, persons with reduced physical, sensory or mental capabilities or lack of experience and knowledge or people unfamiliar with these instructions to use the blower. Local regulations may restrict the age of the operator.

3. Electric shock could occur if used on wet surfaces. Do not expose to rain. Store indoors.
4. Keep in mind, that the operator or user is responsible for accidents or hazards occurring to other people or their property.

Preparation

5. Obtain ear protection and safety glasses. Wear them at all times while operating the blower.
6. Always wear substantial footwear and long trousers while operating the blower.
7. Do not wear loose clothing or jewellery that can be drawn into the air inlet. Keep long hair away from the air inlets.
8. To prevent dust irritation the wearing of a face mask is recommended.

Operation

9. Operate the blower in a recommended position and only on a firm, level surface.
10. Never point the nozzle at anyone in the vicinity when using the blower.
11. Never block suction inlet and/or blower outlet.
 - Do not block suction inlet or blower outlet to clean up in dusty areas.
 - Do not use the blower with a tapered nozzle smaller than the original one, such as a new nozzle obtained by attaching an extra diameter-reduced hose or smaller hose to the nozzle top end.
 - Do not use the blower to inflate balls, rubber boat or the similar.

Increased motor revolution may cause dangerous fan breakage and result in serious personal injury. Heated motor and control circuit may cause a fire.
12. Do not overreach and keep proper balance and footing at all times. Always be sure of the footing on slopes and to walk, never run.
13. Do not operate the blower on a paved or gravel surface where ejected material could cause injury.
14. Never operate the blower while people, especially children, or pets are nearby.
15. Do not operate the blower near open window, etc.
16. Operating the blower only at reasonable hours is recommended - not early in the morning or late at night when people might be disturbed.

17. Using rakes and brooms to loosen debris before blowing is recommended.
18. It is recommended to slightly dampen surfaces in dusty conditions or use mister attachment available on the market.
19. It is recommended to use the long nozzle so the air stream can work close to the ground.
20. If the blower strikes any foreign objects or should start making any unusual noise or vibration, immediately switch off the blower to stop it. Remove the battery cartridge from the blower and take the following steps before restarting and operating the blower:
 - inspect for damage,
 - when the blower is damaged, have it repaired by Makita Authorized Service Centers.
21. Switch off the blower and remove the battery cartridge and make sure that all moving parts have come to a complete stop
 - whenever you leave the blower,
 - before clearing blockages or unclogging chute,
 - before checking, cleaning or working on the blower,
 - if the blower starts to vibrate abnormally, for immediately check, or
 - after striking a foreign object to inspect the blower for damage.
22. Do not insert fingers or other objects into suction inlet or blower outlet.
23. Prevent unintentional starting. Ensure the switch is in the off-position before inserting battery pack, picking up or carrying the blower. Carrying the blower with your finger on the switch or energising the blower that has the switch on invites accidents.

Maintenance and storage

24. When the blower is stopped for servicing, inspection, or storage, or to change an accessory, shut off the power source, remove the battery cartridge from the blower and make sure that all moving parts come to a complete stop. Cool down the blower before making any inspections, adjustments, etc. Maintain the blower with care and keep it clean.
25. Store the blower in a dry place out of the reach of children.
26. Always cool down the blower before storing.
27. Keep all nuts, bolts and screws tight to be sure the blower is in safe working condition.

Battery tool use and care

28. Recharge only with the charger specified by the manufacturer. A charger that is suitable for one type of battery pack may create a risk of fire when used with another battery pack.
29. Use the blower only with specifically designated battery packs. Use of any other battery packs may create a risk of injury and fire.

SAVE THESE INSTRUCTIONS.

⚠WARNING: DO NOT let comfort or familiarity with product (gained from repeated use) replace strict adherence to safety rules for the subject product. MISUSE or failure to follow the safety rules stated in this instruction manual may cause serious personal injury.

Important safety instructions for battery cartridge

1. Before using battery cartridge, read all instructions and cautionary markings on (1) battery charger, (2) battery, and (3) product using battery.
2. Do not disassemble battery cartridge.
3. If operating time has become excessively shorter, stop operating immediately. It may result in a risk of overheating, possible burns and even an explosion.
4. If electrolyte gets into your eyes, rinse them out with clear water and seek medical attention right away. It may result in loss of your eyesight.
5. Do not short the battery cartridge:
 - (1) Do not touch the terminals with any conductive material.
 - (2) Avoid storing battery cartridge in a container with other metal objects such as nails, coins, etc.
 - (3) Do not expose battery cartridge to water or rain. A battery short can cause a large current flow, overheating, possible burns and even a breakdown.
6. Do not store the tool and battery cartridge in locations where the temperature may reach or exceed 50 °C (122 °F).
7. Do not incinerate the battery cartridge even if it is severely damaged or is completely worn out. The battery cartridge can explode in a fire.
8. Be careful not to drop or strike battery.
9. Do not use a damaged battery.
10. The contained lithium-ion batteries are subject to the Dangerous Goods Legislation requirements. For commercial transports e.g. by third parties, forwarding agents, special requirement on packaging and labeling must be observed. For preparation of the item being shipped, consulting an expert for hazardous material is required. Please also observe possibly more detailed national regulations. Tape or mask off open contacts and pack up the battery in such a manner that it cannot move around in the packaging.
11. Follow your local regulations relating to disposal of battery.

SAVE THESE INSTRUCTIONS.

⚠CAUTION: Only use genuine Makita batteries. Use of non-genuine Makita batteries, or batteries that have been altered, may result in the battery bursting causing fires, personal injury and damage. It will also void the Makita warranty for the Makita tool and charger.

Tips for maintaining maximum battery life

1. Charge the battery cartridge before completely discharged. Always stop tool operation and charge the battery cartridge when you notice less tool power.
2. Never recharge a fully charged battery cartridge. Overcharging shortens the battery service life.
3. Charge the battery cartridge with room temperature at 10 °C - 40 °C (50 °F - 104 °F). Let a hot battery cartridge cool down before charging it.
4. Charge the battery cartridge if you do not use it for a long period (more than six months).

FUNCTIONAL DESCRIPTION

⚠ CAUTION:

- Always be sure that the tool is switched off and the battery cartridge is removed before adjusting or checking function on the tool.

Installing or removing battery cartridge

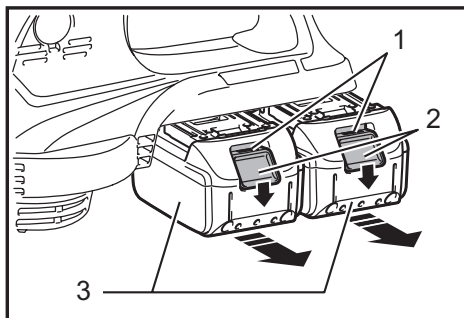

► 1. Red indicator 2. Button 3. Battery cartridge

⚠ CAUTION:

- Always switch off the tool before installing or removing of the battery cartridge.
- **Hold the tool and the battery cartridge firmly when installing or removing battery cartridge.** Failure to hold the tool and the battery cartridge firmly may cause them to slip off your hands and result in damage to the tool and battery cartridge and a personal injury.

To remove the battery cartridge, slide it from the tool while sliding the button on the front of the cartridge. To install the battery cartridge, align the tongue on the battery cartridge with the groove in the housing and slip it into place. Insert it all the way until it locks in place with a little click. If you can see the red indicator on the upper side of the button, it is not locked completely.

⚠ CAUTION:

- Always install the battery cartridge fully until the red indicator cannot be seen. If not, it may accidentally fall out of the tool, causing injury to you or someone around you.
- Do not install the battery cartridge forcibly. If the cartridge does not slide in easily, it is not being inserted correctly.

NOTE:

- The tool does not work with only one battery cartridge.

Tool / battery protection system

The tool is equipped with a tool/battery protection system. This system automatically cuts off power to the motor to extend tool and battery life.

The tool will automatically stop during operation if the tool or battery are placed under one of the following conditions. In some conditions, the indicators light up.

Overload protection

When the tool is operated in a manner that causes it to draw an abnormally high current, the tool automatically stops without any indication. In this situation, turn the tool off and stop the application that caused the tool to become overloaded. Then turn the tool on to restart.

Overheat protection for battery

When the battery is overheated, the tool stops automatically without any indication. The tool does not start even if pressing the switch button. In this situation, let the battery cool before turning the tool on again.

NOTE: The battery overheat protection works only with a battery cartridge with a star marking.

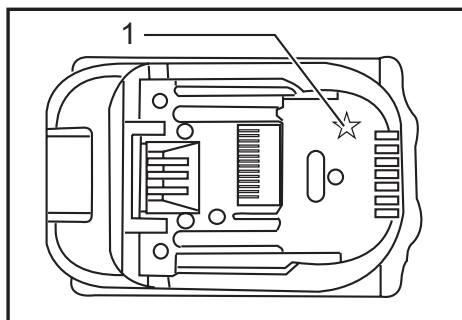

► 1. Star marking

Overdischarge protection

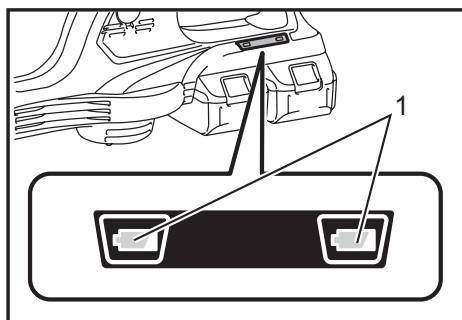

► 1. Battery indicator

When the remaining battery capacity gets low, the battery indicator blinks on the applicable battery side. By further use, the tool stops and the battery indicator lights up about 10 seconds. In this situation, charge the battery cartridge.

Indicating the remaining battery capacity

Only for battery cartridges with the indicator

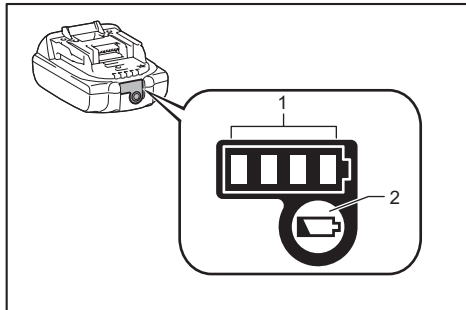

► 1. Indicator lamps 2. Check button

Press the check button on the battery cartridge to indicate the remaining battery capacity. The indicator lamps light up for few seconds.

Indicator lamps			Remaining capacity
Lighted	Off	Blinking	
■	■ ■ ■ ■		75% to 100%
■	■ ■ ■ □		50% to 75%
■	■ □ □ □		25% to 50%
■	□ □ □ □		0% to 25%
▣	□ □ □ □		Charge the battery.
■ ■ □ □	□ □		The battery may have malfunctioned.
□ □ ■ ■		↑ ↓	

NOTE: Depending on the conditions of use and the ambient temperature, the indication may differ slightly from the actual capacity.

Switch action

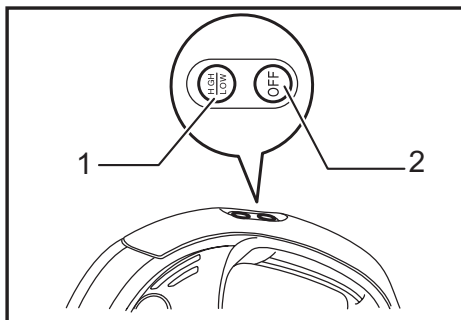

► 1. HIGH/LOW button 2. OFF button

To start the tool, simply press the "HIGH/LOW" button. To switch off, press the "OFF" button. To change the tool speed, press the "HIGH/LOW" button. The first press on this button is for high speed and the second press for low speed and then each press on this button repeats the high/low speed cycle alternatively.

ASSEMBLY

⚠ CAUTION:

- Always be sure that the tool is switched off and the battery cartridge is removed before carrying out any work on the tool.

Installing or removing the long nozzle

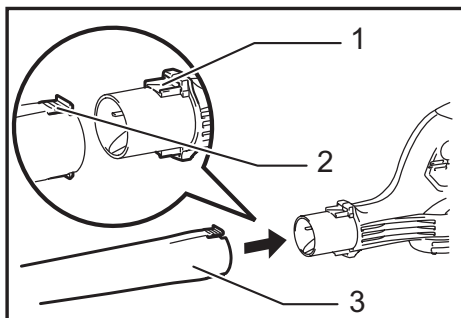

► 1. Hook 2. Button 3. Long nozzle

To install the long nozzle, push in onto the blower outlet of the tool all the way.

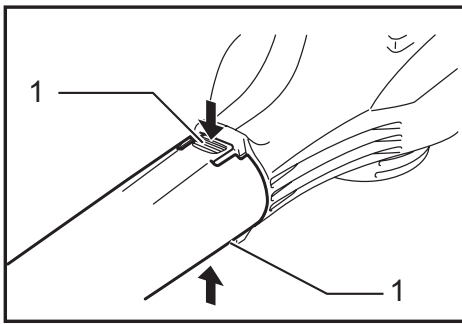

► 1. Button

To remove the long nozzle, press its both buttons and with the buttons being pressed pull it out.

Installing the shoulder strap

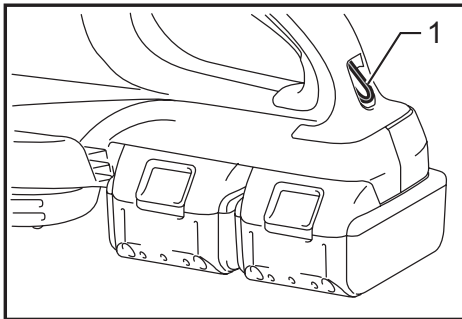

► 1. Hanger

Pull the hanger out of the tool.
Hook the shoulder strap onto the hanger of the tool.
Before use, adjust the length of strap so that it is easy to work with it.

OPERATION

Blowing

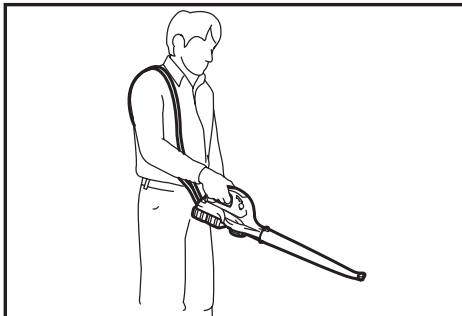

Hold the blower firmly with a hand and perform the blowing operation by moving it around slowly.
When blowing around a building, a big stone or a vehicle, direct the nozzle away from them.
When performing an operation in corner, start from the corner and then move to wide area.

MAINTENANCE

⚠ CAUTION:

- Always be sure that the tool is switched off and the battery cartridge is removed before attempting to perform inspection or maintenance.
- Never use gasoline, benzene, thinner, alcohol or the like. Discoloration, deformation or cracks may result.

Cleaning

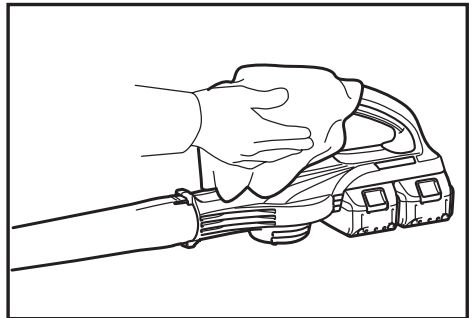

From time to time, wipe off the outside of the tool using a cloth dampened in soapy water.

Replacing carbon brushes

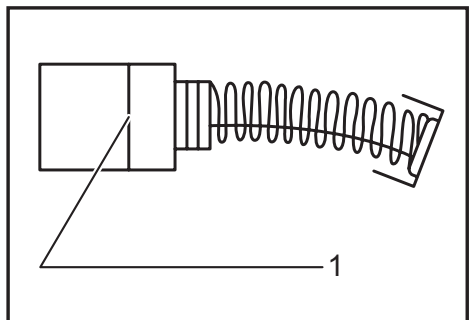

► 1. Limit mark

Remove and check the carbon brushes regularly.
Replace when they wear down to the limit mark. Keep the carbon brushes clean and free to slip in the holders.
Both carbon brushes should be replaced at the same time. Use only identical carbon brushes.

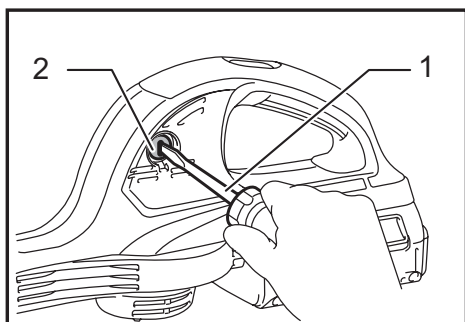

► 1. Screwdriver 2. Brush holder cap

Use a screwdriver to remove the brush holder caps. Take out the worn carbon brushes, insert the new ones and secure the brush holder caps.

To maintain product SAFETY and RELIABILITY, repairs, any other maintenance or adjustment should be performed by Makita Authorized Service Centers, always using Makita replacement parts.

OPTIONAL ACCESSORIES

⚠ CAUTION:

- These accessories or attachments are recommended for use with your Makita tool specified in this manual. The use of any other accessories or attachments might present a risk of injury to persons. Only use accessory or attachment for its stated purpose.

If you need any assistance for more details regarding these accessories, ask your local Makita Service Center.

- Makita genuine battery and charger

NOTE:

- Some items in the list may be included in the tool package as standard accessories. They may differ from country to country.

Makita Corporation

www.makita.com

885330A8 EN 20170106
