

INSTRUCTION MANUAL

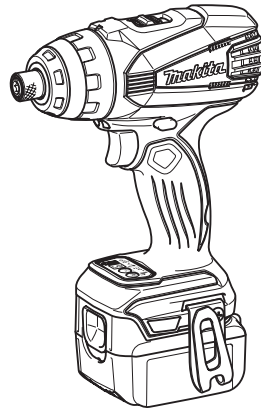

Cordless 4 Mode Impact Driver

DTP131
DTP141



Read before use.

SPECIFICATIONS

Model			DTP131	DTP141	
Impact driver mode	Fastening Capacities	Machine screw	4 mm - 8 mm		
		Standard bolt	5 mm - 14 mm		
		High tensile bolt	5 mm - 12 mm		
	No load speed (min ⁻¹) (Soft / Medium / Hard)		0 - 1,400 / 0 - 2,200 / 0 - 2,800	0 - 1,300 / 0 - 2,200 / 0 - 2,700	
	Impacts per minute (Soft / Medium / Hard)		0 - 1,200 / 0 - 2,400 / 0 - 3,200		
Hammer drill mode	No load speed (min ⁻¹) (Low (1) / High (2))		0 - 700 / 0 - 2,800	0 - 700 / 0 - 2,700	
	Blows per minute (min ⁻¹) (Low (1) / High (2))		0 - 8,400 / 0 - 32,400		
	Drilling Capacities / Concrete		8 mm		
Drill mode	Drilling Capacities (Low (1) / High (2))	Steel	10 mm / 6.5 mm		
		Wood	21 mm / 12 mm		
	No load speed (min ⁻¹)		0 - 700 / 0 - 2,800	0 - 700 / 0 - 2,700	
Screwdriver mode	Fastening Capacities (Low (1) / High (2))	Machine screw	3.5 mm - 6 mm / 4 mm - 6 mm		
		Self drilling screw	4 mm, 5 mm / 4 mm (Thickness 3.2 mm max.)		
		No load speed (min ⁻¹)		0 - 300 / 0 - 1,100 (depends on torque setting) 0 - 600 / 0 - 2,300 (P mode)	
Net weight			1.5 - 1.7 kg	1.5 - 1.9 kg	
Rated voltage			D.C. 14.4 V	D.C. 18 V	

- Due to our continuing program of research and development, the specifications herein are subject to change without notice.
- Specifications may differ from country to country.
- The weight may differ depending on the attachment(s), including the battery cartridge. The lightest and heaviest combination, according to EPTA-Procedure 01/2014, are shown in the table.

Applicable battery cartridge and charger

Battery cartridge	D.C. 14.4 V Model	BL1415N / BL1430 / BL1430B / BL1440 / BL1450 / BL1460B
	D.C. 18 V Model	BL1815N / BL1820 / BL1820B / BL1830 / BL1830B / BL1840 / BL1840B / BL1850 / BL1850B / BL1860B
Charger	DC18RC / DC18RD / DC18RE / DC18SD / DC18SE / DC18SF	

- Some of the battery cartridges and chargers listed above may not be available depending on your region of residence.

⚠ WARNING: Only use the battery cartridges and chargers listed above. Use of any other battery cartridges and chargers may cause injury and/or fire.

Symbols

The following show the symbols used for the equipment. Be sure that you understand their meaning before use.



Read instruction manual.



Only for EU countries
Do not dispose of electric equipment or battery pack together with household waste material! In observance of the European Directives, on Waste Electric and Electronic Equipment and Batteries and Accumulators and their implementation in accordance with national laws, electric equipment and batteries and battery pack(s) that have reached the end of their life must be collected separately and returned to an environmentally compatible recycling facility.

Intended use

The tool is intended for impact screw driving in wood and for impact drilling in brick, concrete and stone as well as for drilling and screw driving without impact in wood, metal, ceramic and plastic.

General power tool safety warnings

⚠ WARNING: Read all safety warnings, instructions, illustrations and specifications provided with this power tool. Failure to follow all instructions listed below may result in electric shock, fire and/or serious injury.

Save all warnings and instructions for future reference.

The term "power tool" in the warnings refers to your mains-operated (corded) power tool or battery-operated (cordless) power tool.

Work area safety

1. **Keep work area clean and well lit.** Cluttered or dark areas invite accidents.
2. **Do not operate power tools in explosive atmospheres, such as in the presence of flammable liquids, gases or dust.** Power tools create sparks which may ignite the dust or fumes.
3. **Keep children and bystanders away while operating a power tool.** Distractions can cause you to lose control.

Electrical Safety

1. **Power tool plugs must match the outlet. Never modify the plug in any way. Do not use any adapter plugs with earthed (grounded) power tools.** Unmodified plugs and matching outlets will reduce risk of electric shock.
2. **Avoid body contact with earthed or grounded surfaces, such as pipes, radiators, ranges and refrigerators.** There is an increased risk of electric shock if your body is earthed or grounded.
3. **Do not expose power tools to rain or wet conditions.** Water entering a power tool will increase the risk of electric shock.
4. **Do not abuse the cord. Never use the cord for carrying, pulling or unplugging the power tool. Keep cord away from heat, oil, sharp edges or moving parts.** Damaged or entangled cords increase the risk of electric shock.
5. **When operating a power tool outdoors, use an extension cord suitable for outdoor use.** Use of a cord suitable for outdoor use reduces the risk of electric shock.
6. **If operating a power tool in a damp location is unavoidable, use a residual current device (RCD) protected supply.** Use of an RCD reduces the risk of electric shock.
7. **Power tools can produce electromagnetic fields (EMF) that are not harmful to the user.** However, users of pacemakers and other similar medical devices should contact the maker of their device and/or doctor for advice before operating this power tool.

Personal Safety

1. **Stay alert, watch what you are doing and use common sense when operating a power tool. Do not use a power tool while you are tired or under the influence of drugs, alcohol or medication.** A moment of inattention while operating power tools may result in serious personal injury.
2. **Use personal protective equipment. Always wear eye protection.** Protective equipment such as a dust mask, non-skid safety shoes, hard hat or hearing protection used for appropriate conditions will reduce personal injuries.
3. **Prevent unintentional starting. Ensure the switch is in the off-position before connecting to power source and/or battery pack, picking up or carrying the tool.** Carrying power tools with your finger on the switch or energising power tools that have the switch on invites accidents.
4. **Remove any adjusting key or wrench before turning the power tool on.** A wrench or a key left attached to a rotating part of the power tool may result in personal injury.

5. **Do not overreach. Keep proper footing and balance at all times.** This enables better control of the power tool in unexpected situations.
6. **Dress properly. Do not wear loose clothing or jewellery. Keep your hair and clothing away from moving parts.** Loose clothes, jewellery or long hair can be caught in moving parts.
7. **If devices are provided for the connection of dust extraction and collection facilities, ensure these are connected and properly used.** Use of dust collection can reduce dust-related hazards.
8. **Do not let familiarity gained from frequent use of tools allow you to become complacent and ignore tool safety principles.** A careless action can cause severe injury within a fraction of a second.
9. **Always wear protective goggles to protect your eyes from injury when using power tools. The goggles must comply with ANSI Z87.1 in the USA, EN 166 in Europe, or AS/NZS 1336 in Australia/New Zealand. In Australia/New Zealand, it is legally required to wear a face shield to protect your face, too.**

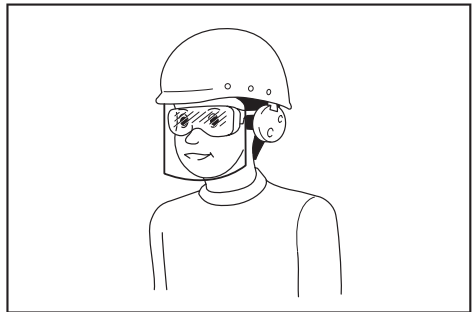

It is an employer's responsibility to enforce the use of appropriate safety protective equipments by the tool operators and by other persons in the immediate working area.

Power tool use and care

1. **Do not force the power tool. Use the correct power tool for your application.** The correct power tool will do the job better and safer at the rate for which it was designed.
2. **Do not use the power tool if the switch does not turn it on and off.** Any power tool that cannot be controlled with the switch is dangerous and must be repaired.
3. **Disconnect the plug from the power source and/or remove the battery pack, if detachable, from the power tool before making any adjustments, changing accessories, or storing power tools.** Such preventive safety measures reduce the risk of starting the power tool accidentally.
4. **Store idle power tools out of the reach of children and do not allow persons unfamiliar with the power tool or these instructions to operate the power tool.** Power tools are dangerous in the hands of untrained users.
5. **Maintain power tools and accessories. Check for misalignment or binding of moving parts, breakage of parts and any other condition that may affect the power tool's operation. If damaged, have the power tool repaired before use.** Many accidents are caused by poorly maintained power tools.

6. **Keep cutting tools sharp and clean.** Properly maintained cutting tools with sharp cutting edges are less likely to bind and are easier to control.
7. **Use the power tool, accessories and tool bits etc. in accordance with these instructions, taking into account the working conditions and the work to be performed.** Use of the power tool for operations different from those intended could result in a hazardous situation.
8. **Keep handles and grasping surfaces dry, clean and free from oil and grease.** Slippery handles and grasping surfaces do not allow for safe handling and control of the tool in unexpected situations.
9. **When using the tool, do not wear cloth work gloves which may be entangled.** The entanglement of cloth work gloves in the moving parts may result in personal injury.

Battery tool use and care

1. **Recharge only with the charger specified by the manufacturer.** A charger that is suitable for one type of battery pack may create a risk of fire when used with another battery pack.
2. **Use power tools only with specifically designated battery packs.** Use of any other battery packs may create a risk of injury and fire.
3. **When battery pack is not in use, keep it away from other metal objects, like paper clips, coins, keys, nails, screws or other small metal objects, that can make a connection from one terminal to another.** Shorting the battery terminals together may cause burns or a fire.
4. **Under abusive conditions, liquid may be ejected from the battery; avoid contact. If contact accidentally occurs, flush with water. If liquid contacts eyes, additionally seek medical help.** Liquid ejected from the battery may cause irritation or burns.
5. **Do not use a battery pack or tool that is damaged or modified.** Damaged or modified batteries may exhibit unpredictable behaviour resulting in fire, explosion or risk of injury.
6. **Do not expose a battery pack or tool to fire or excessive temperature.** Exposure to fire or temperature above 130 °C may cause explosion.
7. **Follow all charging instructions and do not charge the battery pack or tool outside the temperature range specified in the instructions.** Charging improperly or at temperatures outside the specified range may damage the battery and increase the risk of fire.

Service

1. **Have your power tool serviced by a qualified repair person using only identical replacement parts.** This will ensure that the safety of the power tool is maintained.
2. **Never service damaged battery packs.** Service of battery packs should only be performed by the manufacturer or authorized service providers.
3. **Follow instruction for lubricating and changing accessories.**

Cordless 4 Mode Impact Driver Safety Warnings

1. **Wear ear protectors when impact drilling.** Exposure to noise can cause hearing loss.
2. **Use auxiliary handle(s), if supplied with the tool.** Loss of control can cause personal injury.
3. **Hold the power tool by insulated gripping surfaces, when performing an operation where the fastener may contact hidden wiring.** Fasteners contacting a "live" wire may make exposed metal parts of the power tool "live" and could give the operator an electric shock.
4. **Hold the power tool by insulated gripping surfaces, when performing an operation where the cutting accessory may contact hidden wiring.** Cutting accessory contacting a "live" wire may make exposed metal parts of the power tool "live" and could give the operator an electric shock.
5. **Always be sure you have a firm footing. Be sure no one is below when using the tool in high locations.**
6. **Hold the tool firmly.**
7. **Keep hands away from rotating parts.**
8. **Do not leave the tool running. Operate the tool only when hand-held.**
9. **Do not touch the bit or the workpiece immediately after operation; they may be extremely hot and could burn your skin.**
10. **Some material contains chemicals which may be toxic. Take caution to prevent dust inhalation and skin contact. Follow material supplier safety data.**
11. **Always secure workpiece in a vise or similar hold-down device.**

SAVE THESE INSTRUCTIONS.

⚠WARNING: DO NOT let comfort or familiarity with product (gained from repeated use) replace strict adherence to safety rules for the subject product.

MISUSE or failure to follow the safety rules stated in this instruction manual may cause serious personal injury.

Important safety instructions for battery cartridge

1. **Before using battery cartridge, read all instructions and cautionary markings on (1) battery charger, (2) battery, and (3) product using battery.**
2. **Do not disassemble battery cartridge.**
3. **If operating time has become excessively shorter, stop operating immediately. It may result in a risk of overheating, possible burns and even an explosion.**
4. **If electrolyte gets into your eyes, rinse them out with clear water and seek medical attention right away. It may result in loss of your eyesight.**

5. **Do not short the battery cartridge:**
 - (1) **Do not touch the terminals with any conductive material.**
 - (2) **Avoid storing battery cartridge in a container with other metal objects such as nails, coins, etc.**
 - (3) **Do not expose battery cartridge to water or rain.**

A battery short can cause a large current flow, overheating, possible burns and even a breakdown.

6. **Do not store the tool and battery cartridge in locations where the temperature may reach or exceed 50 °C (122 °F).**
7. **Do not incinerate the battery cartridge even if it is severely damaged or is completely worn out. The battery cartridge can explode in a fire.**
8. **Be careful not to drop or strike battery.**
9. **Do not use a damaged battery.**
10. **The contained lithium-ion batteries are subject to the Dangerous Goods Legislation requirements.**

For commercial transports e.g. by third parties, forwarding agents, special requirement on packaging and labeling must be observed.

For preparation of the item being shipped, consulting an expert for hazardous material is required. Please also observe possibly more detailed national regulations.

Tape or mask off open contacts and pack up the battery in such a manner that it cannot move around in the packaging.

11. **Follow your local regulations relating to disposal of battery.**
12. **Use the batteries only with the products specified by Makita.** Installing the batteries to non-compliant products may result in a fire, excessive heat, explosion, or leak of electrolyte.

SAVE THESE INSTRUCTIONS.

CAUTION: Only use genuine Makita batteries. Use of non-genuine Makita batteries, or batteries that have been altered, may result in the battery bursting causing fires, personal injury and damage. It will also void the Makita warranty for the Makita tool and charger.

Tips for maintaining maximum battery life

1. **Charge the battery cartridge before completely discharged. Always stop tool operation and charge the battery cartridge when you notice less tool power.**
2. **Never recharge a fully charged battery cartridge. Overcharging shortens the battery service life.**
3. **Charge the battery cartridge with room temperature at 10 °C - 40 °C (50 °F - 104 °F). Let a hot battery cartridge cool down before charging it.**
4. **Charge the battery cartridge if you do not use it for a long period (more than six months).**

FUNCTIONAL DESCRIPTION

CAUTION:

- Always be sure that the tool is switched off and the battery cartridge is removed before adjusting or checking function on the tool.

Installing or removing battery cartridge

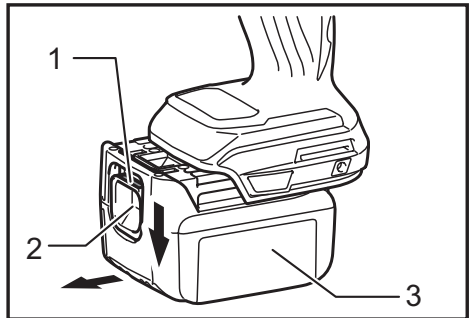

► 1. Red indicator 2. Button 3. Battery cartridge

CAUTION:

- Always switch off the tool before installing or removing of the battery cartridge.
- **Hold the tool and the battery cartridge firmly when installing or removing battery cartridge.** Failure to hold the tool and the battery cartridge firmly may cause them to slip off your hands and result in damage to the tool and battery cartridge and a personal injury.

To remove the battery cartridge, slide it from the tool while sliding the button on the front of the cartridge. To install the battery cartridge, align the tongue on the battery cartridge with the groove in the housing and slip it into place. Insert it all the way until it locks in place with a little click. If you can see the red indicator on the upper side of the button, it is not locked completely.

CAUTION:

- Always install the battery cartridge fully until the red indicator cannot be seen. If not, it may accidentally fall out of the tool, causing injury to you or someone around you.
- Do not install the battery cartridge forcibly. If the cartridge does not slide in easily, it is not being inserted correctly.

Battery protection system (Lithium-ion battery with star marking)

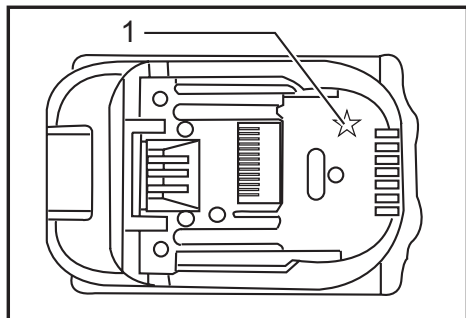

► 1. Star marking

Lithium-ion batteries with a star marking are equipped with a protection system. This system automatically cuts off power to the tool to extend battery life.

The tool will automatically stop during operation if the tool and/or battery are placed under one of the following conditions:

- **Overloaded:**
The tool is operated in a manner that causes it to draw an abnormally high current. In this situation, release the trigger switch on the tool and stop the application that caused the tool to become overloaded. Then pull the trigger switch again to restart. If the tool does not start, the battery is overheated. In this situation, let the battery cool before pulling the trigger switch again.
- **Low battery voltage:**
The remaining battery capacity is too low and the tool will not operate. In this situation, remove and recharge the battery.

Indicating the remaining battery capacity

Only for battery cartridges with the indicator

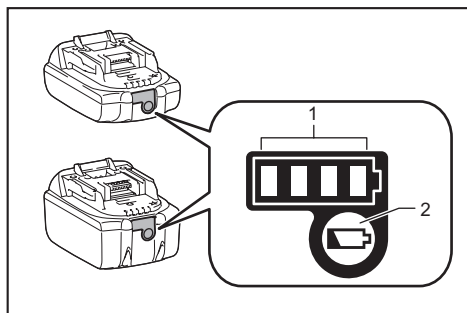

► 1. Indicator lamps 2. Check button

Press the check button on the battery cartridge to indicate the remaining battery capacity. The indicator lamps light up for a few seconds.

Indicator lamps			Remaining capacity
Lighted	Off	Blinking	
■ ■ ■ ■			75% to 100%
■ ■ ■	□		50% to 75%
■ ■	□ □		25% to 50%
■	□ □ □		0% to 25%
▬	□ □ □		Charge the battery.
■ ■ □ □	□ □	↑ ↓	The battery may have malfunctioned.

NOTE: Depending on the conditions of use and the ambient temperature, the indication may differ slightly from the actual capacity.

Switch action

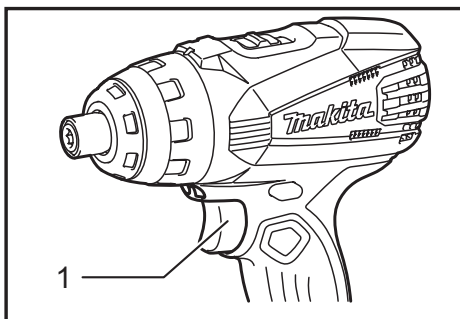

► 1. Switch trigger

⚠ CAUTION:

- Before installing the battery cartridge into the tool, always check to see that the switch trigger actuates properly and returns to the "OFF" position when released.

To start the tool, simply pull the switch trigger. The tool speed is increased by increasing pressure on the switch trigger. Release the switch trigger to stop.

NOTE:

- The tool will stop three minutes after pulling the switch trigger.

Lighting up the front lamp

CAUTION:

- Do not look in the lamp or see the source of lamp directly.

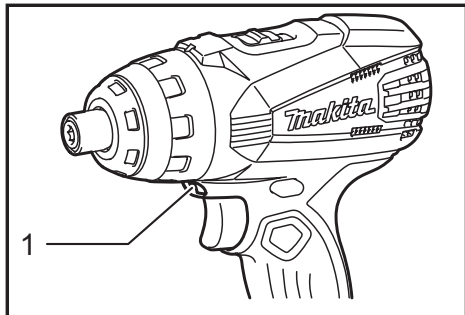

► 1. Lamp

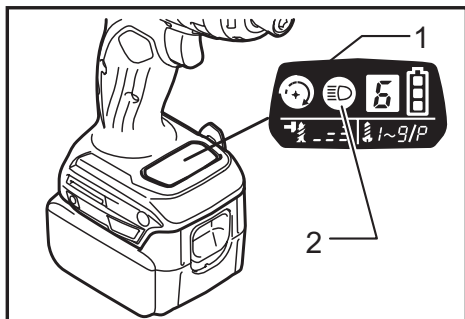

► 1. LED display 2. Lamp button

Every time the lamp button  on the LED display is pressed, the lamp status is alternatively changed from the ON to the OFF and from the OFF to the ON. With the lamp button in the ON status, pull the switch trigger to turn on the lamp. To turn off, release it and the lamp goes out approximately 10 seconds after releasing.

With the lamp button in the OFF status, even if the trigger is pulled, the lamp will not light on.

NOTE:

- To make sure the status of lamp, pull the trigger. When the lamp lights up by pulling the switch trigger, the lamp switch is in the ON status. When the lamp does not come on, the lamp switch is in the OFF status.
- During the operation of switch trigger, the lamp status cannot be changed.
- For approximately 10 seconds after releasing the switch trigger, the lamp status can be switched.

Reversing switch action

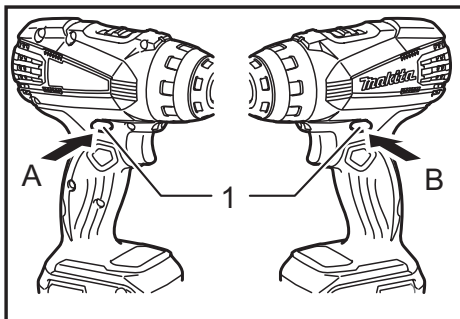

► 1. Reversing switch lever

This tool has a reversing switch to change the direction of rotation. Depress the reversing switch lever from the A side for clockwise rotation or from the B side for counterclockwise rotation.

When the reversing switch lever is in the neutral position, the switch trigger cannot be pulled.

CAUTION:

- Always check the direction of rotation before operation.
- Use the reversing switch only after the tool comes to a complete stop. Changing the direction of rotation before the tool stops may damage the tool.
- When not operating the tool, always set the reversing switch lever to the neutral position.

Speed change

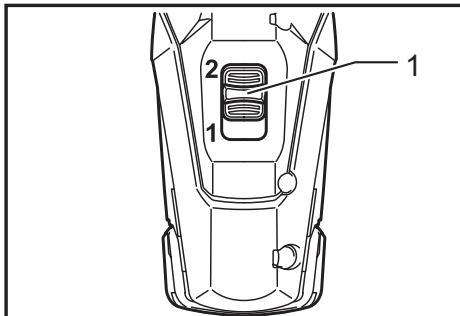

► 1. Speed change lever

NOTICE:

- Always set the speed change lever fully to the correct position. If you operate the tool with the speed change lever positioned halfway between the "1" side and "2" side, the tool may be damaged.
- Do not use the speed change lever while the tool is running. The tool may be damaged.
- Do not force the lever to "1" side with impact driver mode. The tool may be damaged.

To change the speed, first switch off the tool and then slide the speed change lever to the "2" side for high speed or "1" side for low speed. Be sure that the speed change lever is set to the correct position before operation. Use the right speed for your job. When turning the action mode changing ring to impact driver mode, set the speed change lever to the "2" side.

Selecting the action mode

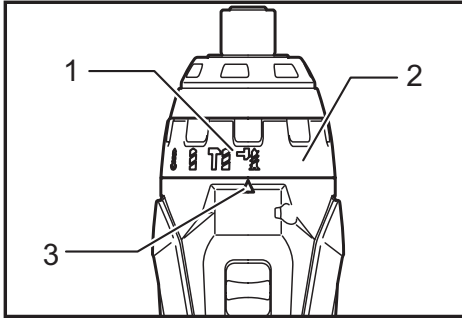



- 1. Mode mark 2. Action mode changing ring
3. Arrow

This tool employs an action mode changing ring. Select one of the 4 modes suitable for your work need by turning this ring.

When driving wood screws or bolts, point the arrow at the  mark for impact driver mode. The impact force can be adjusted on the LED display.

When drilling into concrete or tiles, point the arrow at the  mark for hammer drill mode.

When drilling into wood or metal, point the arrow at the  mark for drill mode.

When driving small wood screws or machine screws, point the arrow at the  mark for screwdriver mode. The fastening torque can be adjusted on the LED display.



CAUTION:

- Always set the arrow correctly to either mode mark. If you operate the tool with the action mode changing ring positioned halfway between the mode marks, the tool may be damaged.
- When turning the action mode changing ring, make sure that the tool stops. If the ring does not easily move, pull the switch trigger slightly to rotate the spindle and then move the ring.
- In the hammer drill mode or drill mode, the blowing force or torque is not adjustable. In those modes, the number on the LED display will be off.

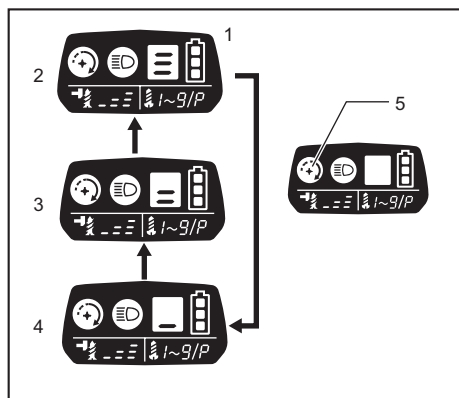
Changing the impact force (impact driver mode)



1. Changed in three steps 2. Hard 3. Medium 4. Soft 5. Control button

Impact force grade displayed on panel	Maximum blows		Application	Work
	DTP131	DTP141		
Hard 	3,200 (min ⁻¹)	3,200 (min ⁻¹)	Tightening when force and speed are desired.	Tightening in underwork material/ Tightening long screws/ Tightening bolts.
Medium 	2,400 (min ⁻¹)	2,400 (min ⁻¹)	Tightening when a good finishing is needed.	Tightening in the finishing board, plaster board.
Soft 	1,200 (min ⁻¹)	1,200 (min ⁻¹)	Tightening when excessive tightening need to be avoided because of potentially clogged female screw and broken or damaged screw head.	Tightening sash screw/ Tightening small screws such as M6.

The impact force can be changed in three steps: hard, medium and soft.



This allows a tightening suitable to the work.

Every time the button  is pressed, the impact force grade changes in three steps.

For approximately one minute after releasing the switch trigger, the impact force can be changed.

NOTE: During the operation of switch trigger, the impact force grade cannot be changed.

Changing the torque setting (screwdriver mode)

The fastening torque can be adjusted by pressing the button  in screwdriver mode. The numbers on the LED display shows torque setting. The fastening torque is minimum at the number 1 and maximum at the number 9. The indication "P" is a special mode for fastening self drilling screws. Every time the button  is pressed, the torque setting changes from 1 to 9 and P, and then returns to 1. The torque setting changes fast by keeping pressing the button. P mode is suitable for fastening self drilling screws into steel plates in the following conditions.

- With speed change lever at "2" side, fastening max. 4 mm screw into total max. 3.2 mm steel plates.
- With speed change lever at "1" side, fastening max. 5 mm screw.

Before an actual operation, drive a trial screw into your material or a piece of duplicate material to determine which torque level is required for a particular application. First, try to fasten the screw at "1". Then increase the number to continue fastening. Hold the tool firmly during operation.

CAUTION: Don't fasten the machine screw on P mode. It may twist your wrist suddenly and result in personal injury.

NOTE:

- Make sure to check the number on LED display before operation. If the number is not indicated, contact your nearest Makita service center.
- When the remaining battery capacity gets low in the screwdriver mode, the light flashes a few times when fastening the screw completely. In this case, recharge the battery. If you keep operating, you may not obtain the desired torque.
- During pulling the switch trigger, the torque setting cannot be changed.
- For approximately one minute after releasing the switch trigger, the torque setting can be changed. if you want to change the torque setting after that, pull the switch trigger again.
- The number of torque setting does not mean specific torque rate.

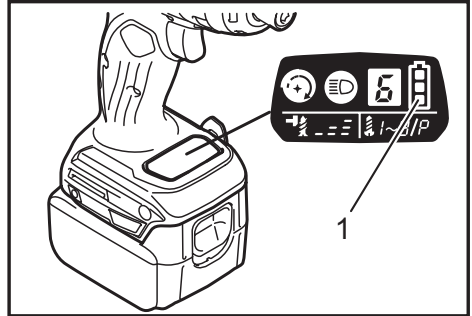

Empty signal for remaining battery capacity

(Country specific)



► 1. Battery capacity

The remaining battery capacity will be signaled on the LED display when pulling the switch trigger. The remaining battery capacity is shown as the following table.

LED indicator status	Remaining battery capacity
	About 50% or more
	About 20% - 50%
	About less than 20%

NOTE:

- When the LED display goes off, the tool is turned off to save the battery power. To check the remaining battery capacity, slightly pull the switch trigger.
- The LED display goes off approximately one minute after releasing the switch trigger.
- When the temperature of the tool gets high, the light flashes once per second for one minute, and then the LED display goes off. In this case, cool down the tool before operation.

ASSEMBLY

⚠ CAUTION:

- Always be sure that the tool is switched off and the battery cartridge is removed before carrying out any work on the tool.

Installing or removing driver/drill/ socket bit

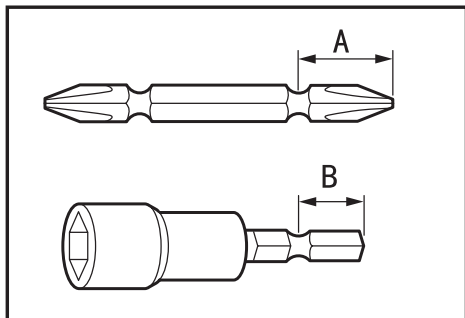

Use only the driver/drill/socket bit shown in the figure. Do not use any other driver/drill/socket bit.

For tool with shallow bit hole

A=12 mm B=9 mm	Use only these type of bit. Follow the procedure (1). (Note) Bit-piece is not necessary.
-------------------	---

For tool with deep bit hole

A=17 mm B=14 mm	To install these types of bits, follow the procedure (1).
A=12 mm B=9 mm	To install these types of bits, follow the procedure (2). (Note) Bit-piece is necessary for installing the bit.

- To install the bit, pull the sleeve and insert the bit into the sleeve as far as it will go. Then release the sleeve to secure the bit.

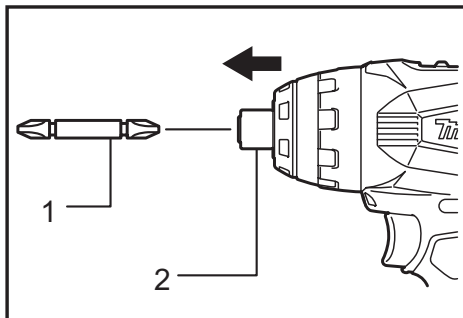

- 1. Bit 2. Sleeve

- To install the bit, insert the bit-piece and bit into the sleeve as far as it will go. The bit-piece should be inserted into the sleeve with its pointed end facing in. Then release the sleeve to secure the bit.

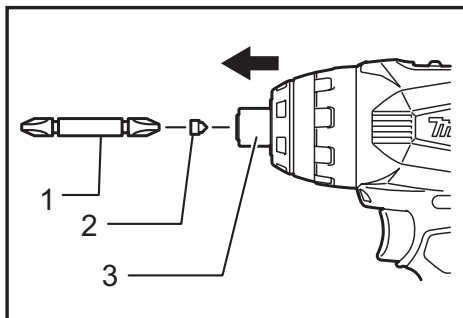

- 1. Bit 2. Bit-piece 3. Sleeve

To remove the bit, pull the sleeve in the direction of the arrow and pull the bit out firmly.

⚠ CAUTION:

- Do not touch the drill bit shortly after operating as it gets hot. Replace the drill bit after cooling it down.

NOTE:

- If the bit is not inserted deep enough into the sleeve, the sleeve will not return to its original position and the bit will not be secured. In this case, try re-inserting the bit according to the instructions above.
- After inserting the bit, make sure that it is firmly secured. If it comes out, do not use it.

Hook (Optional accessory)

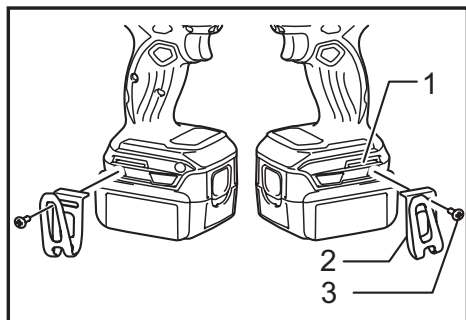

► 1. Groove 2. Hook 3. Screw

CAUTION:

- When installing the hook, tighten the screw firmly. Failure to do so may cause the breakage of the tool or personal injury.

The hook is convenient for temporarily hanging the tool. This can be installed on either side of the tool.

To install the hook, insert it into a groove in the tool housing on either side and then secure it with a screw. To remove, loosen the screw and then take it out.

OPERATION

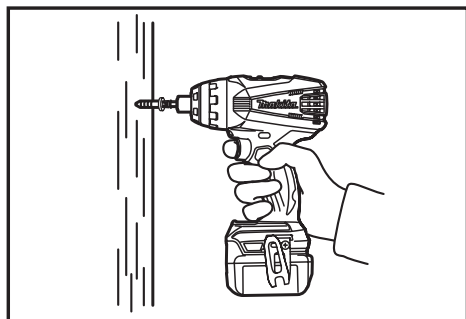

CAUTION:

- Always insert the battery cartridge all the way until it locks in place with a little click. If you can see the red indicator on the upper side of the button, it is not locked completely. Install it fully until the red indicator cannot be seen. If not, it may accidentally fall out of the tool, causing injury to you or someone around you.
- If the tool is operated continuously until the battery cartridge has discharged, allow the tool to rest for 15 minutes before proceeding with a fresh battery.

Impact driver mode

CAUTION:

- When changing the action mode to the impact driver mode, always check that the tool impacts by tightening wood screws. If the action mode is not changed completely, the tool twists the operator's hand resulting injury.

Screwdriving

Hold the tool firmly and place the point of the driver bit in the screw head. Apply forward pressure to the tool to the extent that the bit will not slip off the screw and turn the tool on to start operation.

Tightening bolts

The proper fastening torque may differ depending upon the kind or size of the screw/bolt, the material of the workpiece to be fastened, etc. The relation between fastening torque and fastening time is shown in the figures.

Standard bolt

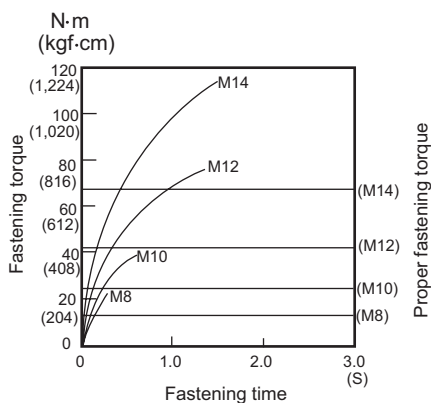

High tensile bolt

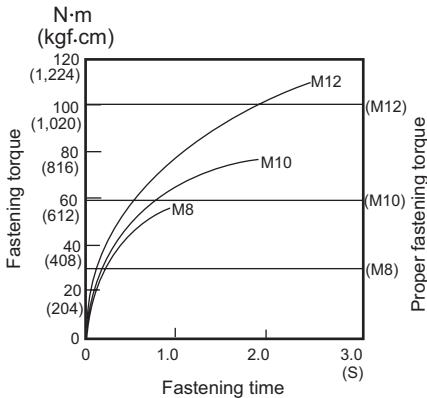

NOTE:

- When the action mode is set to impact driver mode, make sure that the tool impacts properly by fastening a wood screw before operation. If the tool does not work properly, contact your nearest Makita service center.
- Hold the tool pointed straight at the screw.
- Use the proper bit for the head of the screw/bolt that you wish to use.
- When fastening screw M8 or smaller, carefully adjust pressure on the switch trigger so that the screw is not damaged.
- If you tighten the screw for a time longer than shown in the figures, the screw or the point of the driver bit may be overstressed, stripped, damaged, etc. Before starting your job, always perform a test operation to determine the proper fastening time for your screw.

The fastening torque is affected by a wide variety of factors including the following. After fastening, always check the torque with a torque wrench.

1. When the battery cartridge is discharged almost completely, voltage will drop and the fastening torque will be reduced.
2. Driver bit or socket bit
Failure to use the correct size driver bit or socket bit will cause a reduction in the fastening torque.
3. Bolt
 - Even though the torque coefficient and the class of bolt are the same, the proper fastening torque will differ according to the diameter of bolt.
 - Even though the diameters of bolts are the same, the proper fastening torque will differ according to the torque coefficient, the class of bolt and the bolt length.

4. The manner of holding the tool or the material of driving position to be fastened will affect the torque.
5. Operating the tool at low speed will cause a reduction in the fastening torque.

Hammer drill mode

CAUTION:

- Always hold the tool firmly during operation. There is a tremendous and sudden twisting force exerted on the tool/bit at the time of hole break-through, when the hole becomes clogged with chips and particles, or when striking reinforcing rods embedded in the concrete.

Be sure to use a tungsten-carbide tipped bit. Position the bit at the desired location for the hole, then pull the switch trigger. Do not force the tool. Light pressure gives best results. Keep the tool in position and prevent it from slipping away from the hole. Do not apply more pressure when the hole becomes clogged with chips or particles. Instead, run the tool at an idle, then remove the bit partially from the hole. By repeating this several times, the hole will be cleaned out and normal drilling may be resumed.

Drilling mode

CAUTION:

- Pressing excessively on the tool will not speed up the drilling. In fact, this excessive pressure will only serve to damage the tip of your bit, decrease the tool performance and shorten the service life of the tool.
- There is a tremendous force exerted on the tool/bit at the time of hole break through. Hold the tool firmly and exert care when the bit begins to break through the workpiece.
- A stuck bit can be removed simply by setting the reversing switch to reverse rotation in order to back out. However, the tool may back out abruptly if you do not hold it firmly.
- Always secure small workpieces in a vise or similar hold-down device.
- Do not pull the switch trigger repeatedly when the motor is locked. It may damage the tool.

For drilling in wood, the best results are obtained with wood drills equipped with a guide screw. The guide screw makes drilling easier by pulling the bit into the workpiece.

For drilling in metal, to prevent the bit from slipping when starting a hole, make an indentation with a center-punch and hammer at the point to be drilled. Place the point of the bit in the indentation and start drilling. Use a cutting lubricant when drilling metals. The exceptions are iron and brass which should be drilled dry.

NOTE:

- Choose suitable speed for the work load. Drilling over the following capacity may damage the tool.

	Drilling capacity	
	High speed	Steel
Wood		12 mm
Low speed	Steel	10 mm
	Wood	21 mm

Screwdriver mode

⚠ CAUTION:

- Adjust the number on the LED display to the proper torque level for your work.
- Make sure that the driver bit is inserted straight in the screw head, or the screw and/or bit may be damaged.
- Hold the tool firmly. When the clutch cuts in or refastening, a sudden twisting force may occur and it can twist your wrist.

Place the point of the driver bit in the screw head and apply pressure to the tool. Start the tool slowly and then increase the speed gradually.

NOTE:

- This tool employs an electronic clutch. The tool stops automatically when the clutch cuts in. To keep operating, release the switch trigger once.
- When driving wood screws, predrill pilot holes to make driving easier and to prevent splitting of the workpiece. See the chart.

Nominal diameter of wood screw (mm)	Recommended size of pilot hole (mm)
3.1	2.0 - 2.2
3.5	2.2 - 2.5
3.8	2.5 - 2.8
4.5	2.9 - 3.2
4.8	3.1 - 3.4
5.1	3.3 - 3.6
5.5	3.7 - 3.9
5.8	4.0 - 4.2
6.1	4.2 - 4.4

NOTE:

- See the following chart for the relation between the number of torque setting and fastening torque rate.
The fastening torque rate will be different depends on materials. Make a test fastening to get the desired torque before operation.

Number on LED Display	Fastening torque rate	
	Low (1)	High (2)
1	Approx. 2.5 N·m (Approx. 25.5 kgf·cm)	Approx. 1.1 N·m (Approx. 11.2 kgf·cm)
3	Approx. 4.6 N·m (Approx. 46.9 kgf·cm)	Approx. 2.0 N·m (Approx. 20.4 kgf·cm)
5	Approx. 8.1 N·m (Approx. 82.6 kgf·cm)	Approx. 3.0 N·m (Approx. 30.6 kgf·cm)
7	Approx. 10.0 N·m (Approx. 102.0 kgf·cm)	Approx. 4.0 N·m (Approx. 40.8 kgf·cm)
9	Approx. 11.5 N·m (Approx. 117.3 kgf·cm)	Approx. 5.8 N·m (Approx. 59.1 kgf·cm)

MAINTENANCE

⚠ CAUTION:

- Always be sure that the tool is switched off and the battery cartridge is removed before attempting to perform inspection or maintenance except for the following troubleshooting related to the light.
- Never use gasoline, benzine, thinner, alcohol or the like. Discoloration, deformation or cracks may result.

To maintain product SAFETY and RELIABILITY, repairs, any other maintenance or adjustment should be performed by Makita Authorized Service Centers, always using Makita replacement parts.

OPTIONAL ACCESSORIES

⚠ CAUTION:

- These accessories or attachments are recommended for use with your Makita tool specified in this manual. The use of any other accessories or attachments might present a risk of injury to persons. Only use accessory or attachment for its stated purpose.

If you need any assistance for more details regarding these accessories, ask your local Makita Service Center.

- Screw bits
- Hook
- Plastic carrying case
- Makita genuine battery and charger

NOTE:

- Some items in the list may be included in the tool package as standard accessories. They may differ from country to country.

Makita Corporation

www.makita.com

885309E9 EN 20171026
