



CV100D
DCV200











GB Cordless Heated Vest

Instruction manual

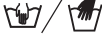

ENGLISH (Original instructions)

SYMBOLS

 Read instructions.
 Not to be used by very young children (0-3 years).
 Do not insert pins.
 Do not dry clean.
 Do not bleach.
 Do not iron.
 Do not tumble dry.
 Hand wash only.
 Hang dry.
 Do not wring or twist.
 Only for EU countries Do not dispose of electric equipment or battery pack together with household waste material! In observance of the European Directives, on Waste Electric and Electronic Equipment and Batteries and Accumulators and Waste Batteries and Accumulators and their implementation in accordance with national laws, electric equipment and batteries and battery pack(s) that have reached the end of their life must be collected separately and returned to an environmentally compatible recycling facility.

Cd
Ni-MH
Li-ion

children aged from 8 years and above and persons with reduced physical, sensory or mental capabilities or lack of experience and knowledge if they have been given supervision or instruction concerning use of the appliance in a safe way and understand the hazards involved. Children shall not play with the appliance. Cleaning and user maintenance shall not be made by children without supervision.

- Not for Europe market: This appliance is not intended for use by persons (including children) with reduced physical, sensory or mental capabilities, or lack of experience and knowledge, unless they have been given supervision or instruction concerning use of the appliance by a person responsible for their safety. Children should be supervised to ensure that they do not play with the appliance.

WARNING:

Read all safety warnings and all instructions. Failure to follow the warnings and instructions may result in electric shock, fire and/or serious injury.

Intended use

The heated vest is intended for warming up the body in cold environments.

General safety warnings

- Children, handicapped persons, or anyone who are insensitive to heat, for example a person with poor blood circulation, shall refrain from using the vest.
- Do not use the vest other than its intended use.
- Never use the vest when inside of it is wet.
- Do not wear the vest with bare skin.
- If you sense anything unusual, switch off the vest and remove the battery holder immediately.

SAFETY INSTRUCTIONS

Important instructions. Retain for future use.

Important safety instruction

- For Europe market: This appliance can be used by

- Do not let the power cable be pinched. Damaged cable may cause electric shock.
- If any abnormality is found, contact your local service center for repair.
- Do not use pins or like. The electric wiring inside may be damaged.
- Keep maintenance labels and nameplate. If they become unreadable or missing, contact your local service center for repair.
- Choose appropriate temperature settings in accordance with the usage environment for continuous use.
- The battery cartridge, battery and connectors must not be allowed to get wet during washing and drying.
- The appliance is not to be used by young children unless the controls have been pre-set by a parent or guardian, or unless the child has been adequately instructed on how to operate the controls safely.

WARNING: In order to avoid the possibility of heatstroke, disconnect the clothing when moving to an environment having significantly higher temperature.

PAY ATTENTION: Check carefully on the marking  in the internal part of the cloth. Do not insert pins on the cloth from external or internal parts.

Washing

- When washing the vest, follow the instructions in the caution tag on the vest.
- Before cleaning the vest, remove the battery holder and the battery cartridge and then place the power cable in the battery holder pocket and close the cover.

Work area safety

- Keep work area clean and well lit. Cluttered or dark areas increase accident risk.

Electrical safety

- Do not expose the vest to rain or wet conditions. Water entering the vest may increase the risk of electric shock.
- Do not abuse the cord. Never use the cord for carrying, pulling or unplugging the vest. Keep cord away from heat, oil, sharp edges.
- Do not connect power source to USB port. Otherwise there is risk of fire. The USB port is only intended for charging lower voltage device. Always place the cover onto the USB port when not charging the lower voltage device.
- Do not insert a nail, wire, etc. into USB power supply port. Otherwise a circuit short may cause smoke and fire.

Personal safety

- Stay alert, watch what you are doing and use common sense when using the vest. Do not use the vest while you are tired or under the influence of drugs, alcohol or medication. A moment of inattention while using the vest may result in serious personal injury.

Vest use and care

- Do not use the vest if the switch does not turn it on and off. Any vest that cannot be controlled with the switch is dangerous and must be repaired.

- Maintain the vest. Check for breakage of parts and any other condition that may affect the vest's operation. If damaged, have the vest repaired before use.
- Use the vest in accordance with these instructions, taking into account the working conditions and the work to be performed. Use of the vest for operations different from those intended could result in a hazardous situation.
- If the fuse link has ruptured, return the vest to our authorized service center for repairing.
- When not in use, store as follows:
 - Allow it to cool down before folding.
 - Do not crease the appliance by placing items on top of it.
- Examine the appliance frequently for signs of wear or damage. If there are such signs or if the appliance has been misused, return it to the supplier to any further use.
- This appliance is not intended for medical use in hospitals.

Important safety instructions for battery cartridge

- Recharge only with the charger specified by the manufacturer. A charger that is suitable for one type of battery pack may create a risk of fire when used with another battery pack.
- Use the vest only with specifically designated battery packs. Use of any other battery packs may create a risk of injury and fire.
- Before using battery cartridge, read all instructions and cautionary markings on (1) battery charger, (2) battery, and (3) product using battery.
- Do not disassemble battery cartridge.
- If operating time has become excessively shorter, stop operating immediately. It may result in a risk of overheating, possible burns and even an explosion.
- Under abusive conditions, liquid may be ejected from the battery; avoid contact. If electrolyte gets into your eyes, rinse them out with clear water and seek medical attention right away. It may result in loss of your eyesight.
- Do not short the battery cartridge:
 1. Do not touch the terminals with any conductive material.
 2. Avoid storing battery cartridge in a container with other metal objects such as nails, coins, etc.
 3. Do not expose battery cartridge to water or rain. A battery short can cause a large current flow, overheating, possible burns and even a breakdown.
- Do not store the vest, battery holder and battery cartridge in locations where the temperature may reach or exceed 50°C (122°F).
- Do not incinerate the battery cartridge even if it is severely damaged or is completely worn out. The battery cartridge can explode in a fire.
- Be careful not to drop or strike battery.
- Do not use a damaged battery.
- Follow your local regulations relating to disposal of battery.

Tips for maintaining maximum battery life

- Never recharge a fully charged battery cartridge. Overcharging shortens the battery service life.

- Charge the battery cartridge with room temperature at 10°C - 40°C (50°F - 104°F).
- Let a hot battery cartridge cool down before charging it.
- Charge the battery cartridge if you do not use it for a long period (more than six months).
- For an optimum life-time, the battery cartridge have to be fully charged, after use.

For United States:

This device complies with Part 15 of the FCC Rules. Operation is subject to the following two conditions: (1) this device may not cause harmful interference, and (2) this device must accept any interference received, including interference that may cause undesired operation.

SAVE THESE INSTRUCTIONS.

(See the last part of this instruction manual for all the illustrations.)

DESIGNATION OF PARTS (Fig. 1)

1. Power button
2. Battery holder pocket (Backside)
3. Power cable (Inside the battery holder pocket)
4. Battery holder

SPECIFICATIONS

Model	CV100D	DCV200		
Temperature adjustment steps	3			
Material	Nylon 100% (outer and lining), polyester 100% (armhole and padding)			
USB power supply port	-	DC 5V, 2.1A		
Operating time (h)	With battery BL1014	With battery BL1450	With battery BL1850	
	Low	APPROX. 4.5	APPROX. 18	APPROX. 28
	Medium	APPROX. 2.5	APPROX. 10	APPROX. 16
	High	APPROX. 1.5	APPROX. 5.5	APPROX. 8
Rated voltage (V)	12 V Max.	14.4	18	
Battery cartridge	BL1014	BL1415, BL1415N, BL1430, BL1440, BL1450	BL1815, BL1815N, BL1820, BL1830, BL1840, BL1850	

- Due to our continuing program of research and development, the specifications herein are subject to change without notice.
- Specifications and battery cartridge may differ from country to country.
- Operating time may differ depending on battery type and usage condition.

FUNCTIONAL DESCRIPTION

Switch action

To turn on the vest, push and hold the power button (about 1.5 seconds). To turn off, push and hold the power button again.

Temperature adjustment

There are three temperature settings (high, medium, low). Three LED lights means that the temperature is set to "high", two LED lights "medium", and one LED light "low". When you switch on the vest, the temperature is set to "high". Each press of the power button cycles through the vest's temperature setting.

ASSEMBLY

⚠ CAUTION:

- Hold the battery holder and the battery cartridge firmly when installing or removing battery cartridge. Failure to hold the battery holder and the battery cartridge firmly may cause them to slip off your

hands and result in damage to the battery holder and battery cartridge and a personal injury.

Installing or removing battery cartridge to the battery holder (Fig. 2)

for CV100D

To install the battery cartridge (5), hold it so that the battery cartridge front shape fits to that of the battery holder opening and slip it into place. Insert it all the way until it locks in place with a little click.

Always insert the battery cartridge all the way until it locks in place. If not, it may accidentally fall out of the battery holder, causing injury to you or someone around you.

Do not install the battery cartridge forcibly. If the cartridge does not slide in easily, it is not being inserted correctly.

To remove the battery cartridge, withdraw it from the battery holder while pressing the buttons (6) on both sides of the cartridge.

for DCV200

To install the battery cartridge (7), align the tongue on the battery cartridge with the groove in the battery holder and slip it into place. Insert it all the way until it locks in place

with a little click. If you can see the red indicator (8) on the upper side of the button, it is not locked completely. Always install the battery cartridge fully until the red indicator cannot be seen. If not, it may accidentally fall out of the battery holder, causing injury to you or someone around you.

Do not install the battery cartridge forcibly. If the cartridge does not slide in easily, it is not being inserted correctly. To remove the battery cartridge, slide it from the battery holder while sliding the button (9) on the front of the cartridge.

Attaching the battery holder to the heated vest

for CV100D (Fig. 3)

Connect the battery holder and the power cable of the vest. Place the battery holder in the battery holder pocket.

for DCV200 (Fig. 4)

You can hang the battery holder on the belt. Firstly pass the vest's power cable through the hole inside the battery holder pocket, and connect the battery holder and the power cable of the vest. And then hang the battery holder on your belt.

Connecting USB device (For DCV200 only) (Fig. 5)

CAUTION:

- Connect only devices which are compatible with DC5V, 2.1A power source to the USB power supply port. Otherwise it may cause malfunction to the battery holder.

The battery holder (with the battery) can work as an external power supply for USB device. Connect the USB cable (not included) with the power supply port of the battery holder. And then connect the other end of the cable with the device. The USB cable can be placed inside the vest for convenience by using the hole of the pocket and cable holder.

NOTE:

- Before connecting USB device to the charger, always backup your data of USB device. Otherwise your data may lose by any possibility.
- The charger may not supply power to some USB devices.
- Wait for 10 seconds before charging another device consecutively.
- When not using or after charging, remove the USB cable and close the cover.

OPTIONAL ACCESSORIES

CAUTION:

These accessories or attachments are recommended for use with your Makita tool specified in this manual. The use of any other accessories or attachments might present a risk of injury to persons. Only use accessory or attachment for its stated purpose.

If you need any assistance for more details regarding these accessories, ask your local Makita Service Center.

- Makita genuine battery and charger

NOTE: Some items in the list may be included in the package as standard accessories. They may differ from country to country.

MAINTENANCE

CAUTION:

Always be sure that the vest is switched off and the battery cartridge is removed before attempting to perform inspection or maintenance.

If vest does not switch on or any fault is found with a fully charged battery cartridge, clean the terminals of the battery holder and the battery cartridge. If vest still does not work properly, stop using the vest and contact our authorized service center.

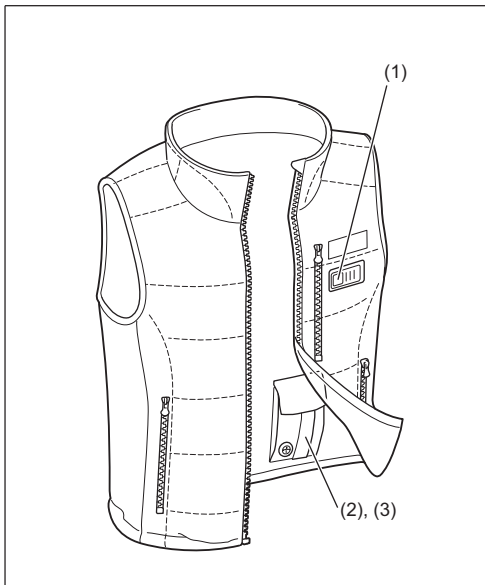

1

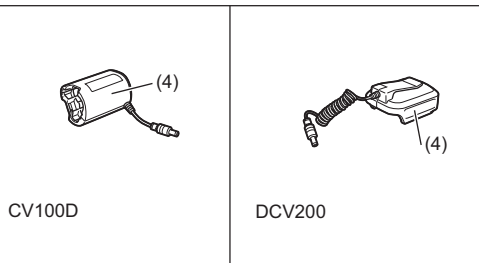

CV100D

DCV200

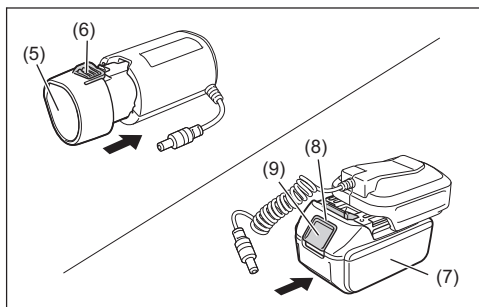

2

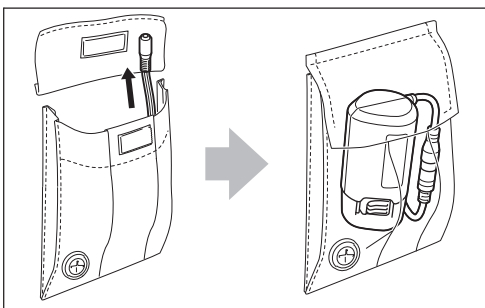

3

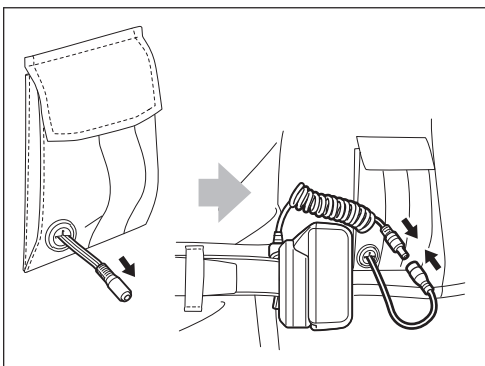

4

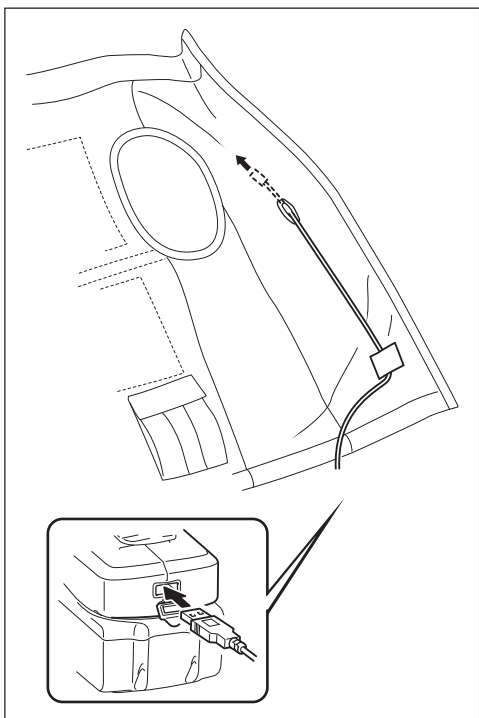

5

Makita Corporation
3-11-8, Sumiyoshi-cho,
Anjo, Aichi 446-8502 Japan

CV100D-NA3-BZ-0715

www.makita.com

ALA