

### Model No.DCS340 ENGINE CHAIN SAW

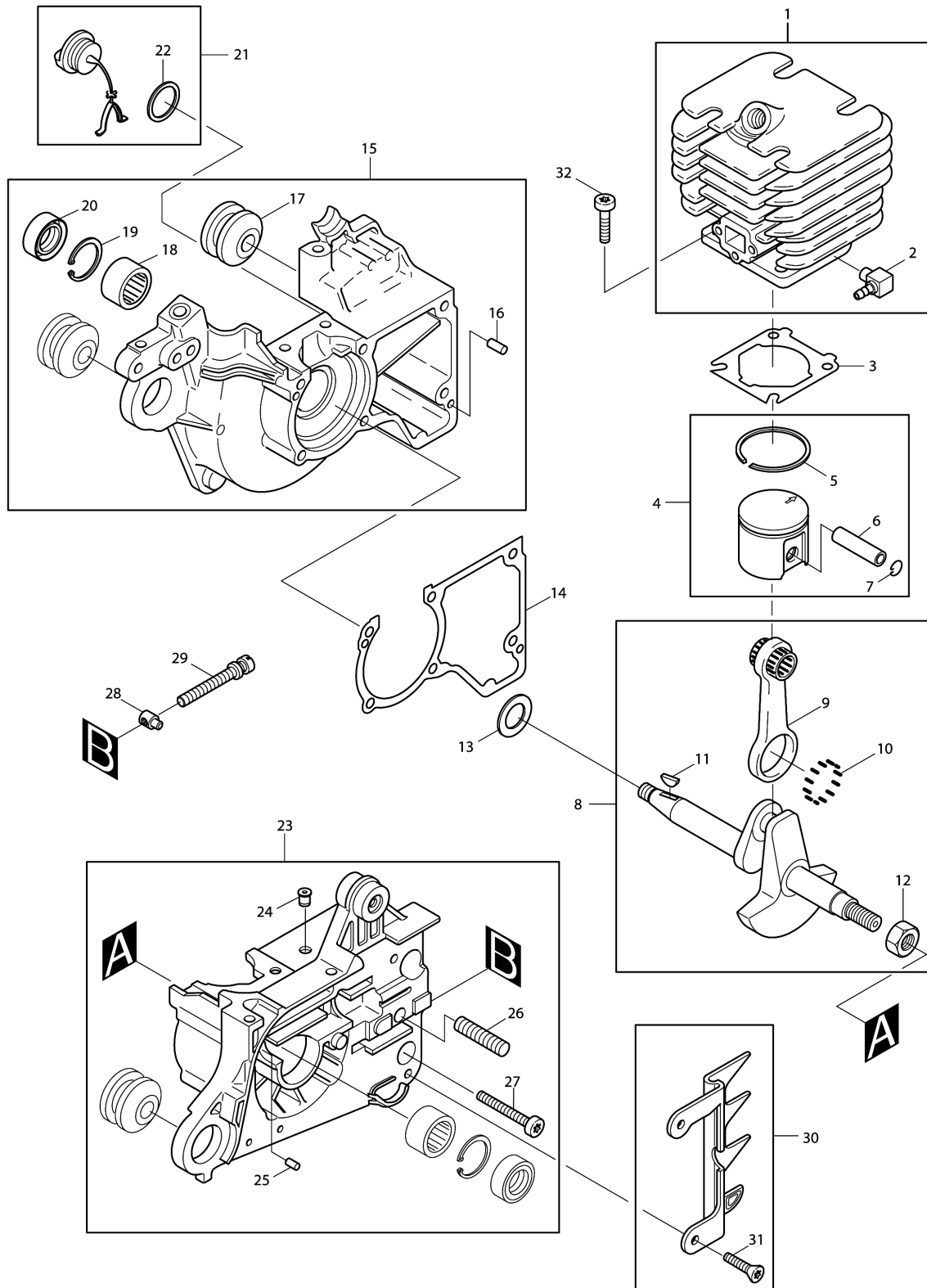

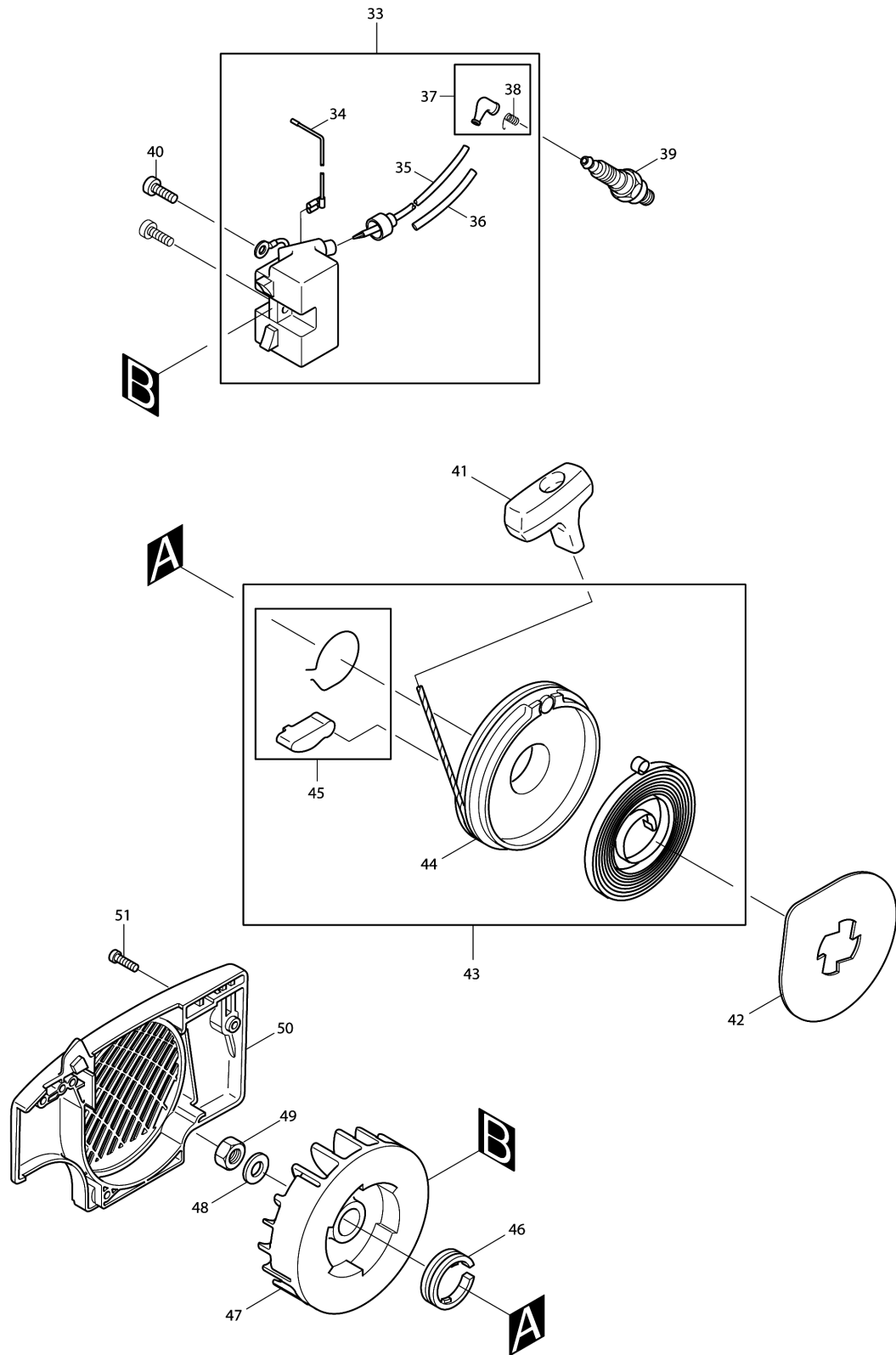

# Model No.DCS340 ENGINE CHAIN SAW





### Model No.DCS340 ENGINE CHAIN SAW

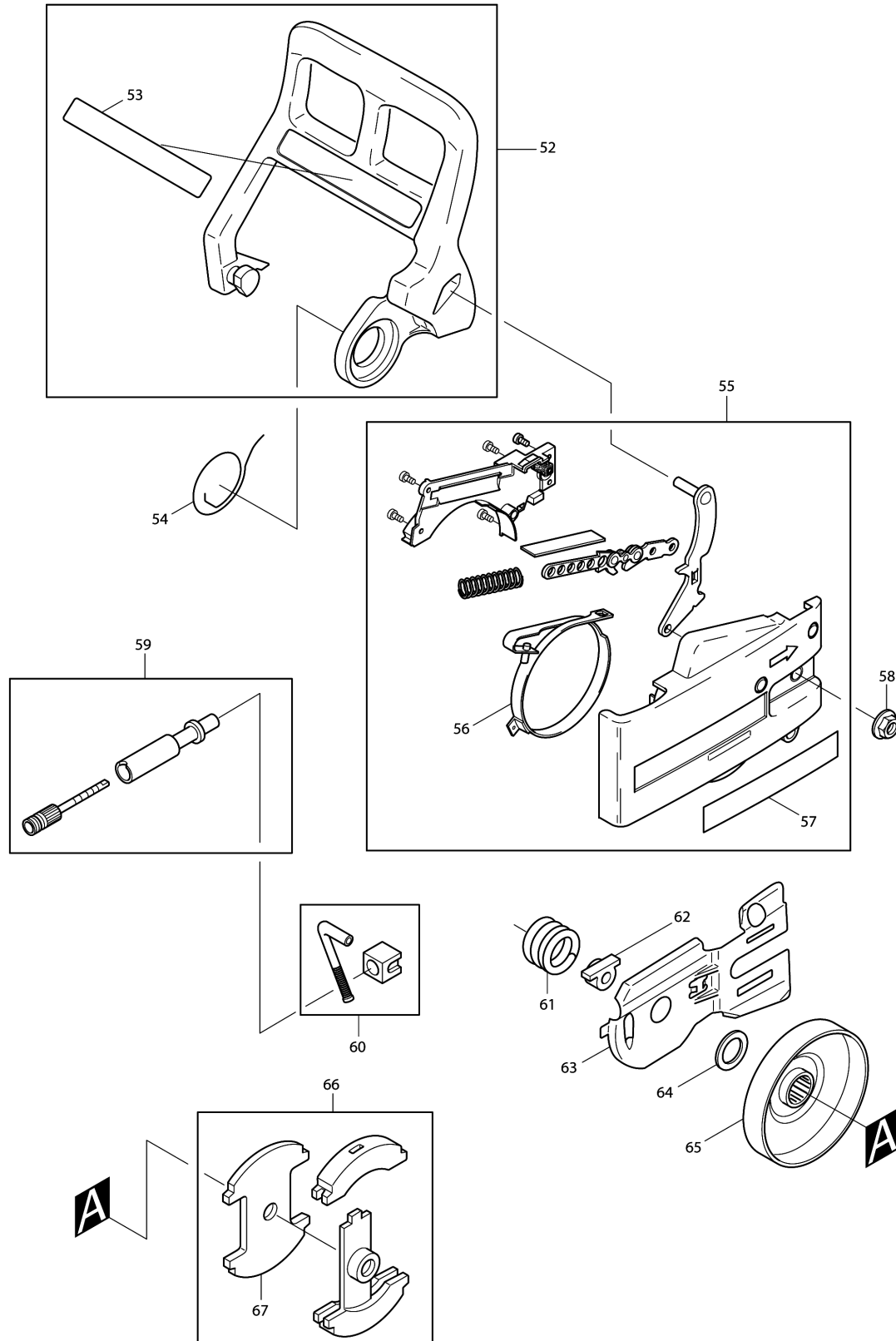



Model No.DCS340 ENGINE CHAIN SAW

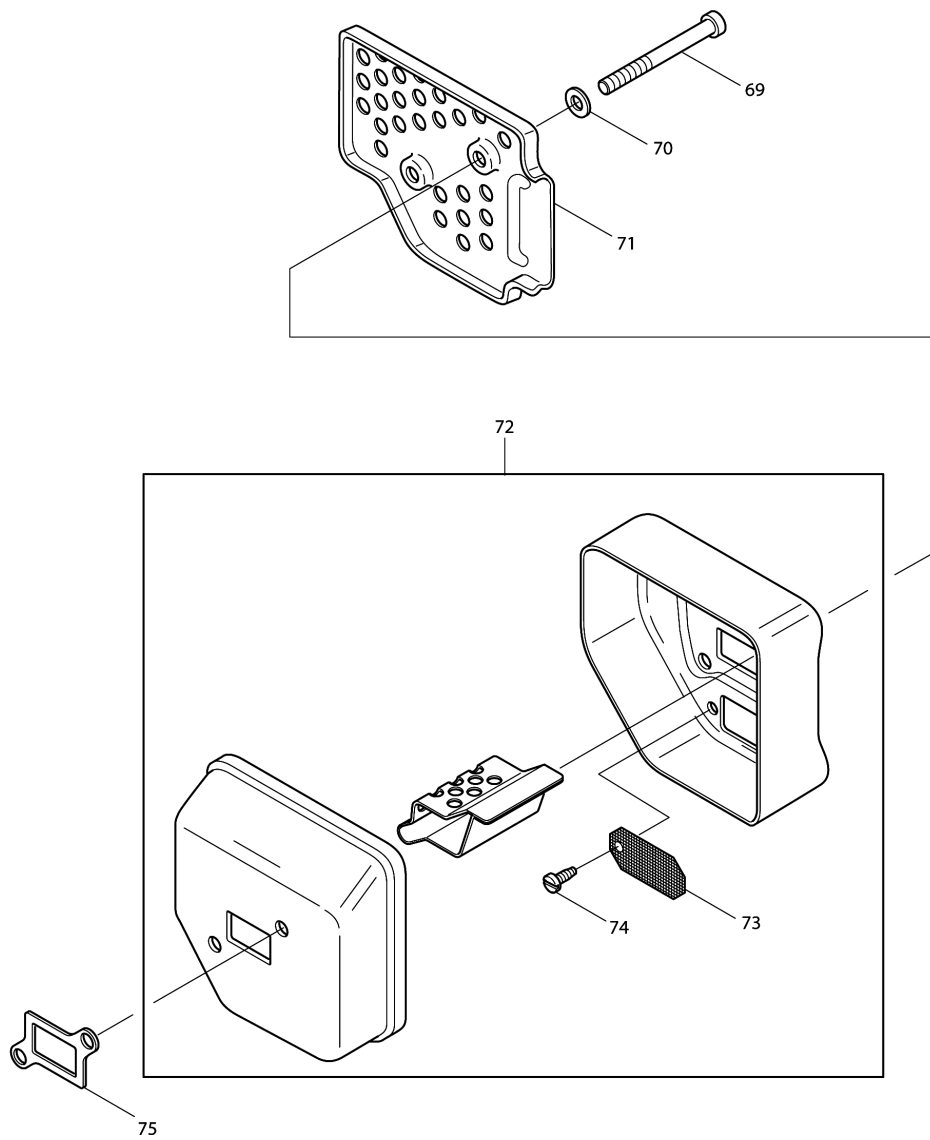





# Model No.DCS340 ENGINE CHAIN SAW

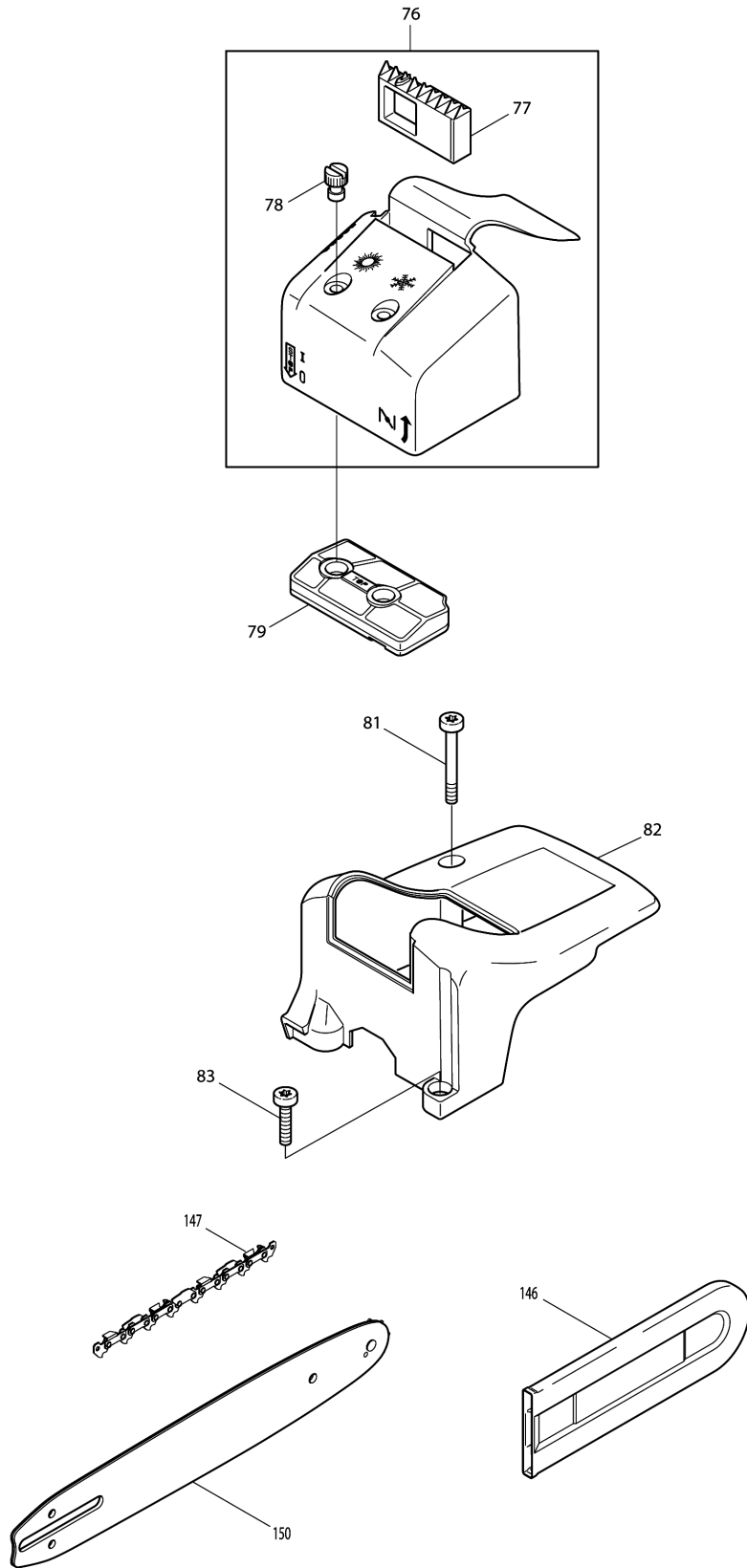



### Model No.DCS340 ENGINE CHAIN SAW

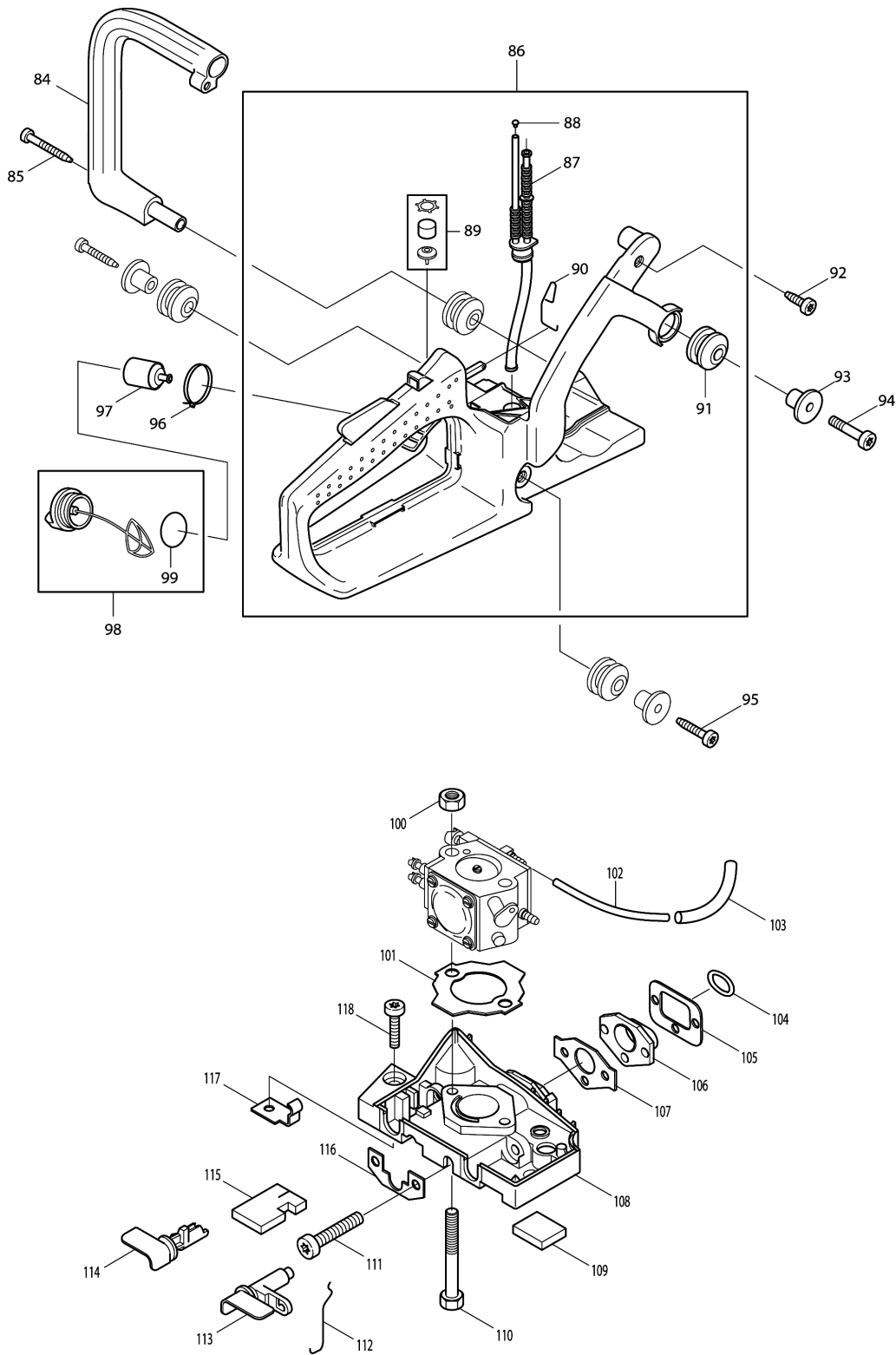



# Model No.DCS340 ENGINE CHAIN SAW

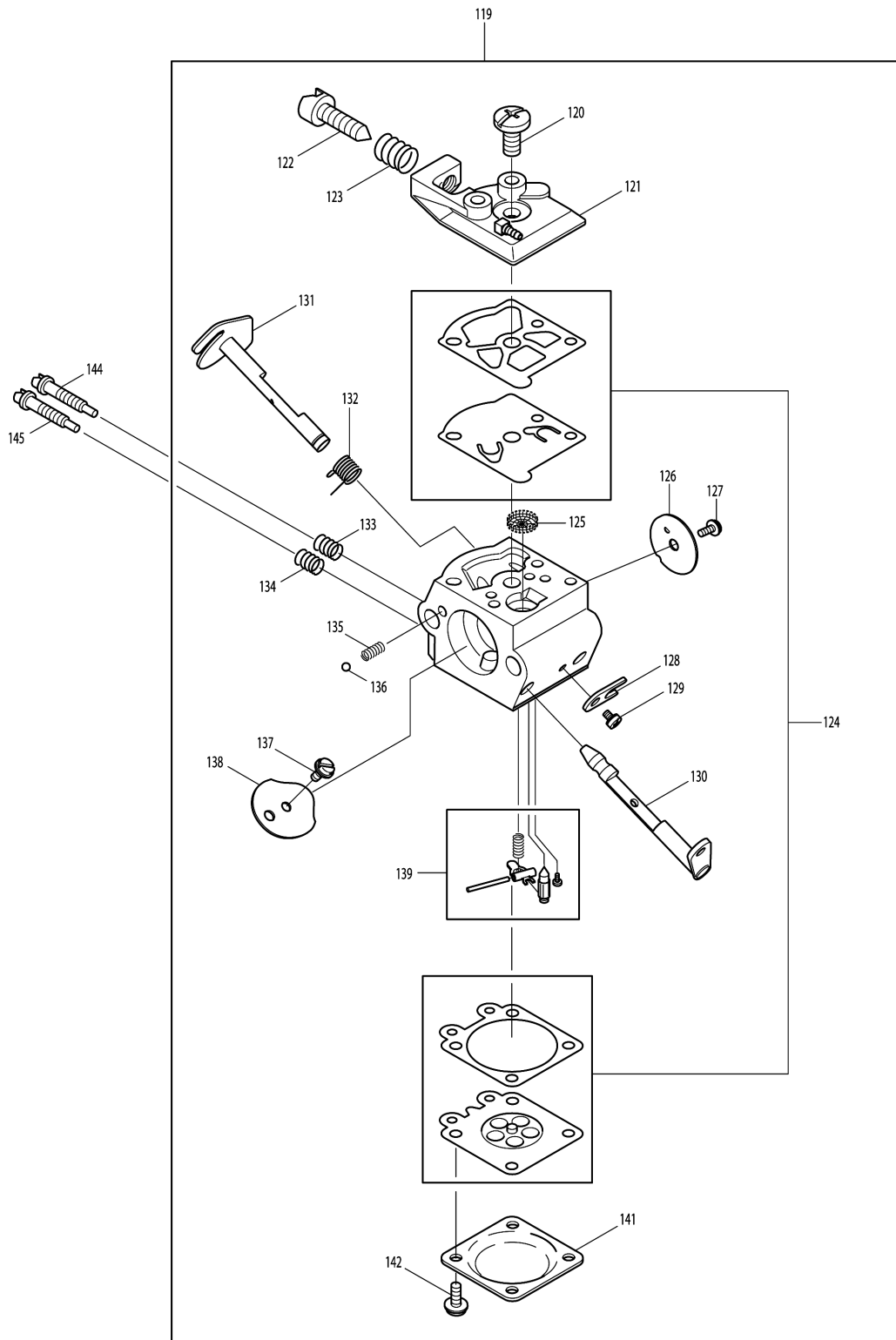



## Model No.DCS340 ENGINE CHAIN SAW

Item	Parts No.	Description	I/C	Qty	New/Old	Opt. 1	Opt. 2	Note
001	021131110	CYLINDER(37MM)		1				
002	001151670	ANGULAR NIPPLE		1				
003	965524042	GASKET		1	*			
003-1	965524043	GASKET	O	1				
004	021132110	PISTON ASSY.		1	*			
D10		INC. 5-7			*			
004-1	021132111	PISTON ASSY.	O	1				
D10		INC. 5-7						
005	021132230	PISTONRING(40MM)		1				
006	021132020	PISTON PIN		1				
007	108132050	CIRCLIP		2				
008	957120028	CRANKSHAFT CPL.		1				
D10		INC. 9-12						
009	021123010	CON-ROD CPL.		1				
010	962640061	ROLLER		12				
011	939615260	KEY		1				
012	920108044	HEXAGONAL NUT, LEFT THR.		1				
013	108121010	STOP DISC		2				
014	965524011	GASKET		1				
015	028111640	CRANKCASE, M. SIDE CPL.		1				
D10		INC. 16-20						
016	936430160	PIN 3X16		2				
017	965403490	RUBBER BUFFER		3				
018	962300011	NEEDLE CAGE		1				
019	929319101	SNAP RING		1				
020	962900049	RADIAL RING		1				
021	965450040	OIL TANK PLUG ASSY.		1	*			
021-1	965450042	OIL TANK PLUG ASSY.	O	1				
022	963100041	GASKET		1	*			
022-1	963100043	GASKET	O	1				
023	028111630	CRANKCASE, CL.SIDE CPL.		1				
D10		INC. 24-26						
024	010245010	VENT VALVE, OIL		1				
025	021245070	GUIDE PIN		1				
026	905808254	BOLT M8X25		1				
027	908005305	H.L. SOCKET HEAD BOLT M5X30		6				
028	001213042	TENSION SLIDE		1				
029	389213080	TENSIONING SCREW		1	*			
029-1	389213081	TENSIONING SCREW	O	1				
030	957250015	SPIKE BAR ASSY.		1				
031	908105124	H.L.S. FLAT HEAD BOLT M5X12		2				

Please order the parts with part number.

Print Date 26/6/2019

## Model No.DCS340 ENGINE CHAIN SAW

Item	Parts No.	Description	I/C	Qty	New/Old	Opt. 1	Opt. 2	Note
032	908405255	H.L. SOCKET HEAD BOLT M5X25		4				
033	028142021	IGNITION ELECTRONIC ASSY.		1				
034	028147000	SHORT-CIRCUIT CABLE		1				
D10		INC. 34-37						
035	970310200	IGNITION CABLE L=1M		1				
036	970502110	INSULATING TUBE 6 L=1M		1				
037	957604260	PLUG CAP CPL.		1				
D10		INC. 38						
038	965604180	PLUG CAP SPRING		1				
039	965603018	SPARK PLUG BPM-R-6F		1				
040	908605145	H.L. SOCKET HEAD BOLT M5X14		2				
041	965404031	STARTER GRIP		1				
042	900004375	DISC		1				
043	021160000	STARTER ASSY.		1	*			
D10		INC. 44-45			*			
043-1	021160001	STARTER ASSY.	<	1				
D10		INC. 44-45						
044	985000150	STARTER ROPE 3.0MM L=100M		1				
045	028166030	STARTER RATCHET/SPRING		1				
046	021166040	SNAP RING		1				
047	021141011	FLYWHEEL		1				
048	928308001	SPRING WASHER 8X17		1				
049	920308024	HEX. NUT M8X1 (FINE THREAD)		1				
050	028112630	FAN HOUSING		1				
051	908005165	FILLISTER HEAD SCREW M5X16		3				
052	028213615	HAND GUARD CPL.		1				
D10		INC. 53						
053	980114237	LABEL		1				
054	028213560	SPRING		1				
055	028213670	CHAIN BRAKE CPL.		1				
D10		INC. 56-58						
056	028213501	BRAKE SPRING		1				
057	980114251	LABEL		1				
058	923208004	HEX. FLANGE NUT M8(BAR NUT)		1				
059	021245003	OIL PUMP CPL.		1				
060	965451962	SUCTION LINE ASSY. FOR OIL		1				
061	021245040	WORM		1				
062	021245080	SEALING CAP		1				
063	021111037	GUIDE PLATE		1				
064	021224010	SHIM		1	*			

Please order the parts with part number.

Print Date 26/6/2019



## Model No.DCS340 ENGINE CHAIN SAW

Item	Parts No.	Description	I/C	Qty	New/Old	Opt. 1	Opt. 2	Note
064-1	021224011	WASHER 10	O	1				
065	028223311	CLUTCH DLUM		1	*			
065-1	028223060	CLUTCH DLUM	O	1				
066	021180011	CLUTCH ASSY.		1				
D10		INC. 67						
067	028184020	FLAT SPRING		2				
069	908205605	FILLISTER HEAD SCREW M5X60		2				
070	928405000	SPRING WASHER 5		2	*			
070-1	928405000	SPRING WASHER 5	O	2				
072	021174301	MUFFLER		1				
075	965524062	GASKET		1				
076	028118320	COVER ASSY.		1				
D10		INC. 77,78						
077	028118180	INSERT		1				
078	001118062	NUT M5		2				
079	028173041	AIR FILTER		1				
081	908205605	FILLISTER HEAD SCREW M5X60		1				
082	028118310	HOOD		1				
083	908005165	FILLISTER HEAD SCREW M5X16		1				
084	028310050	TUBULAR HANDLE		1				
085	913455454	SCREW 5.5X45		1				
086	028114691	TANK ASSY.		1	*			
D10		INC. 87-91			*			
086-1	028114692	TANK COMPLETE	O	1				
D10		INC. 87-91						
087	965404661	FUEL LINE		1	*			
087-1	965404590	FUEL LINE	O	1				
088	937130120	RIVET		1				
089	957114010	VENT VALVE ASSY.		1	*			
089-1	957114011	VENT VALVE ASSY.	O	1				
090	028117244	THROTTLE LINKAGE		1	*			
090-1	028117245	THROTTLE LINKAGE	O	1				
091	965403490	RUBBER BUFFER		1	*			
091-1	965403491	RUBBER BUFFER	O	1				
092	913455204	H.L.TAPPING SCREW 5.5X20		1	*			
092-1	913455204	H.L.TAPPING SCREW 5.5X20	O	1				
093	021114051	FIXING BUSH		3				
094	908005305	H.L. SOCKET HEAD BOLT M5X30		1				
095	913455304	H.L.TAPPING SCREW 5.5X30		2				
096	980003583	CABLE STRAP		1				

Please order the parts with part number.

Print Date 26/6/2019

## Model No.DCS340 ENGINE CHAIN SAW

Item	Parts No.	Description	I/C	Qty	New/Old	Opt. 1	Opt. 2	Note
097	963601130	SUCTION HEAD(FUEL)		1	*			
097-1	963601122	SUCTION HEAD(FUEL)	O	1	*			
097-2	010114010	SUCTION HEAD(FUEL)	O	1				
098	010114050	TANK CAP ASSY		1				
D10		INC. 99						
099	963228030	O-RING 28		1				
100	920205000	HEX. NUT M5		2				
101	965524120	GASKET		1				
102	965452060	TUBE		1				
103	970502110	INSULATING TUBE 6 L=1M		1				
104	965524092	GASKET		1				
105	965524131	GASKET		1				
106	028131061	INTERMEDIATE FLANGE		1				
107	965524082	GASKET		1				
108	028118271	BOTTOM		1				
109	965404430	GASKET		1				
110	900205554	SCREW M5X55		2				
111	908005305	H.L. SOCKET HEAD BOLT M5X30		2				
112	028150750	CHOKE LINKAGE		1				
113	028150740	CHOKE LEVER		1				
114	028118121	STOP SWITCH		1				
115	965404421	GASKET		1				
116	028118160	PLATE		1				
117	028118112	CONTACT PLATE		1	*			
117-1	028118113	CONTACT PLATE	O	1				
118	908005165	FILLISTER HEAD SCREW M5X16		1				
119	028151700	CARBURETOR CPL.		1				
D10		INC. 120-142,144,145						
120	118151190	SCREW		1				
121	001151140	PUMP COVER		1				
122	021151240	ADJUSTING SCREW		1				
123	021151230	PRESSURE SPRING		1				
124	021151540	SET GASKET/DIAPHRAGM		1				
125	021151180	SCREEN		1				
126	108151320	THROTTLE SHUTTER		1				
127	118151060	SCREW		1				
128	108151350	SHAFT CLIP		1				
129	118151020	SCREW		1				
130	001151255	CHOKE SHAFT		1				
131	001151320	THROTTLE SHAFT		1				
132	001151310	SPRING		1				

Please order the parts with part number.

Print Date 26/6/2019

## Model No.DCS340 ENGINE CHAIN SAW

Item	Parts No.	Description	I/C	Qty	New/Old	Opt. 1	Opt. 2	Note
133	021151480	SPRING(L)		1				
134	021151530	SPRING(H)		1				
135	118151160	FRICTION SPRING		1				
136	118151170	FRICTION BALL		1				
137	118151060	SCREW		1				
138	001151350	CHOKE SHUTTER		1				
139	957150040	SET OF CONTROL PARTS		1				
141	021151120	DIAPHRAGM COVER		1				
142	118151020	SCREW		1				
144	021151470	IDLING ADJUSTM. SCREW		1				
145	001151515	MAIN ADJUSTMENT SCREW		1				
146	952100633	CHAIN PROT.COVER 12"-16"		1				
147	528092646	SAW CHAIN 12"		1				
147A_	528092652	SAW CHAIN 14"		1				
147B_	528092656	SAW CHAIN 16"		1				
150	442030661	GUIDE BAR STD 12"3/8".050" M		1				
150A_	442035661	GUIDE BAR STD 14"3/8".050" M		1				
150B_	442040661	GUIDE BAR STD 16"3/8".050" M		1				

Please order the parts with part number.

Print Date 26/6/2019