

Model No.DC18SE CHARGER

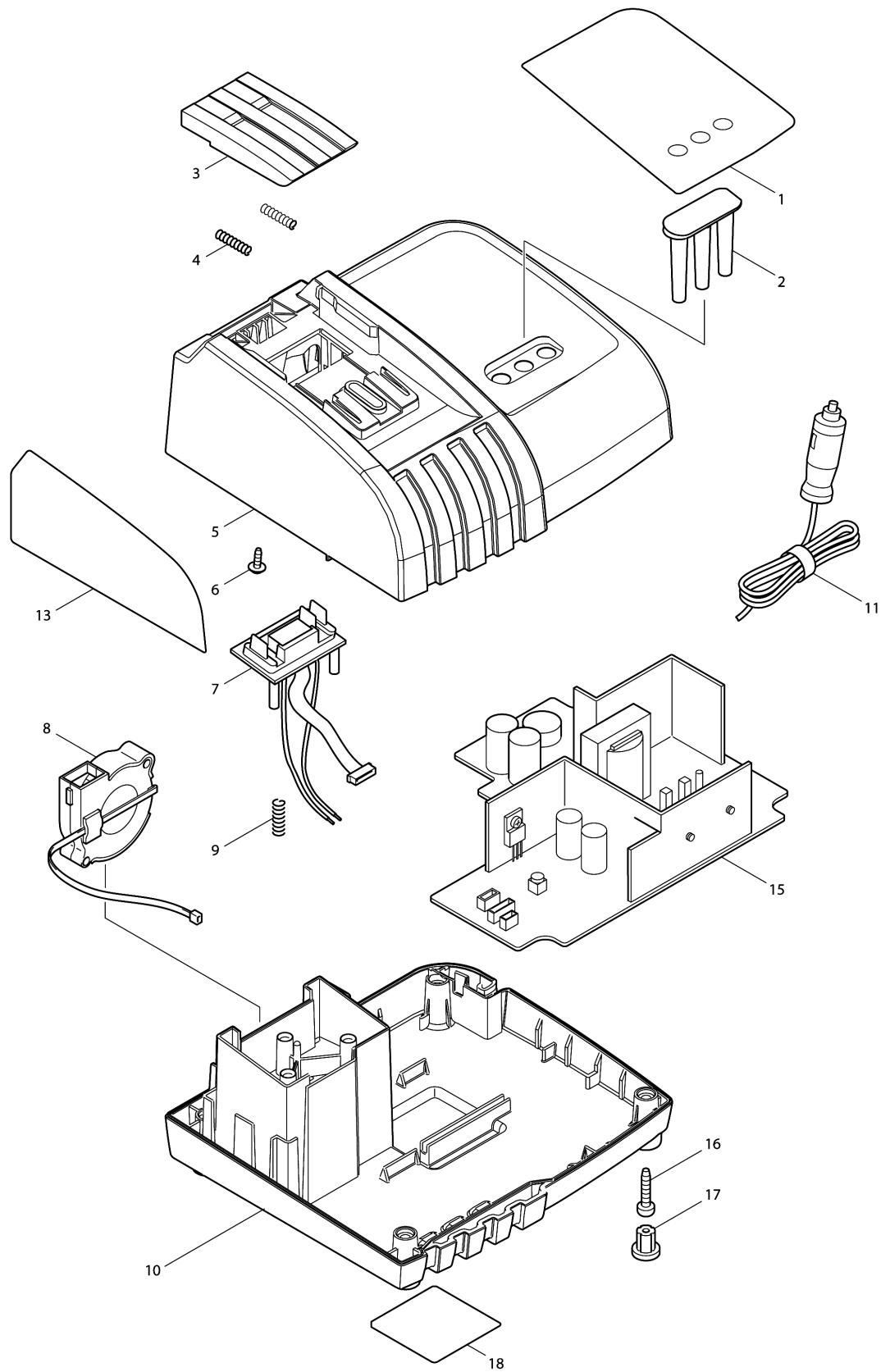

Model No.DC18SE CHARGER

Item	Parts No.	Description	I/C	Qty	New/Old	Opt. 1	Opt. 2	Note
001	807531-8	CHARGING CONDITION LABEL		1				
002	419570-2	ACRYRIC PIN		1				
003	419569-7	TERMINAL COVER		1	*			
003-1	455546-5	TERMINAL COVER	<	1				
004	231474-6	COMPRESSION SPRING 4		2				
005	158135-2	CHARGER CASE COMPLETE		1	*			
D10		INC. 2			*			
005-1	158517-8	CHARGER CASE COMPLETE	<	1				
D10		INC. 2						
006	266278-7	TAPPING SCREW FLANGE BT3X10		1				
007	638602-8	TERMINAL UNIT		1	*			
007-1	638602-8	TERMINAL UNIT	O	1				
008	638499-5	SCIROCCO FAN		1				
009	233194-8	COMPRESSION SPRING 4		1				
010	419567-1	CHARGER CASE COVER		1				
011	667857-8	POWER SUPPLY CORD		1	*			
011-1	667720-5	POWER SUPPLY CORD	<	1				
015	631826-5	CHARGING CIRCUIT		1				
016	266346-6	TAPPING SCREW BT 4X20		4				
017	286255-3	CAP 13		4				
018	865865-5	DC18SE NAME PLATE		1				

Please order the parts with part number.

Print Date 14/5/2019

