

Model No.DC10WD BATTERY CHARGER

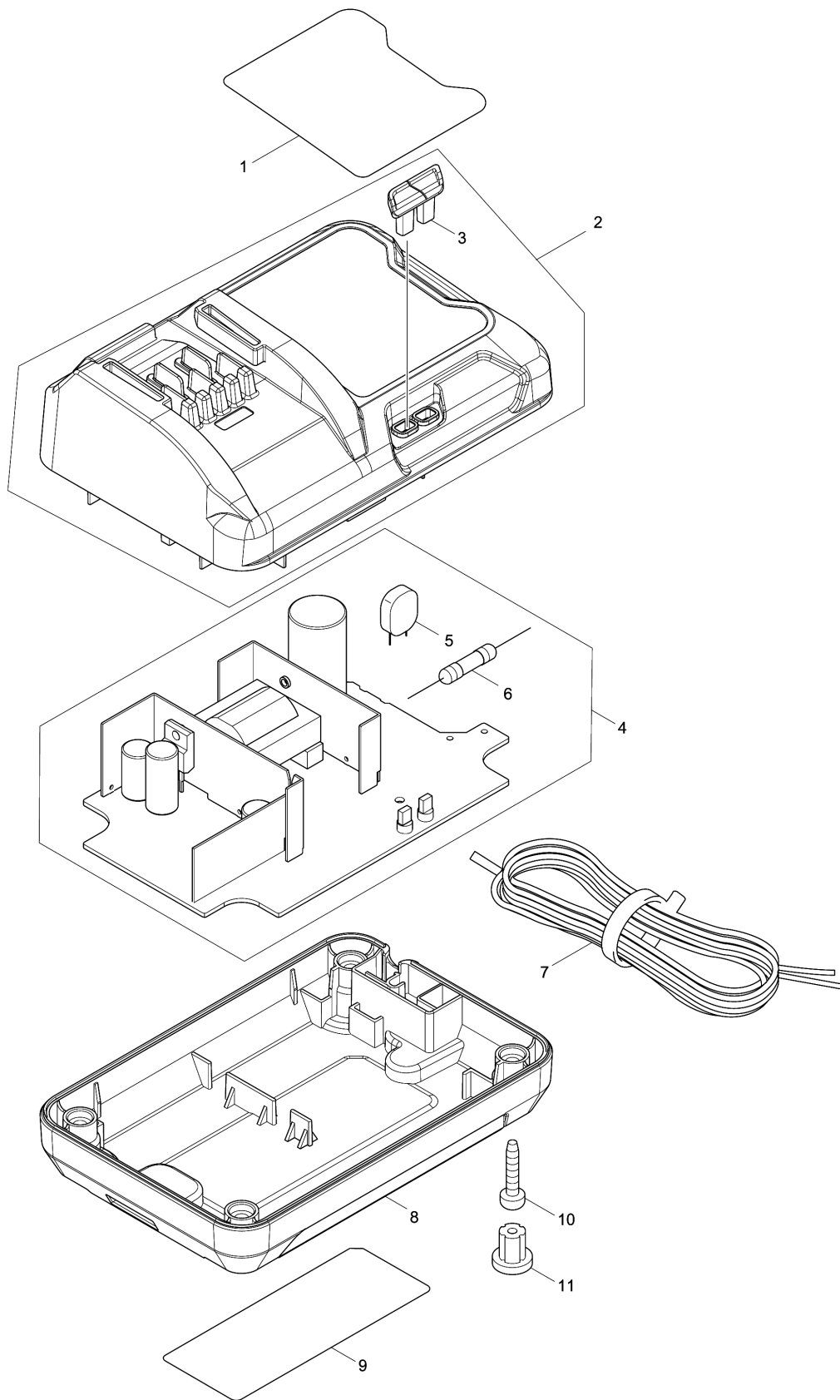

Model No.DC10WD BATTERY CHARGER

Item	Parts No.	Description	I/C	Qty	New/Old	Opt. 1	Opt. 2	Note
001	807B57-2	CHARGING CONDITION LABEL		1				
002	143244-0	CHARGER CASE COMPLETE		1				
D10		INC. 3						
003	455959-0	LENZ		1				
004	620421-6	CHARGING CIRCUIT		1				
D10		INC. 5,6						
005	647306-1	VARISTOR		1				
006	652804-2	FUSE		1				
007	667985-9	VINYL CORD 0.75-2-2.0		1				
008	455958-2	CHARGER CASE COVER		1				
010	266346-6	TAPPING SCREW BT 4X20		4				
011	286255-3	CAP 13		4				
A01C	456128-6	BATTERY COVER		1				
A02C	197396-9	BATTERY BL1021B SET		1				

Please order the parts with part number.

Print Date 4/12/2019

