

# Model No.DBC4010 BRUSH CUTTER

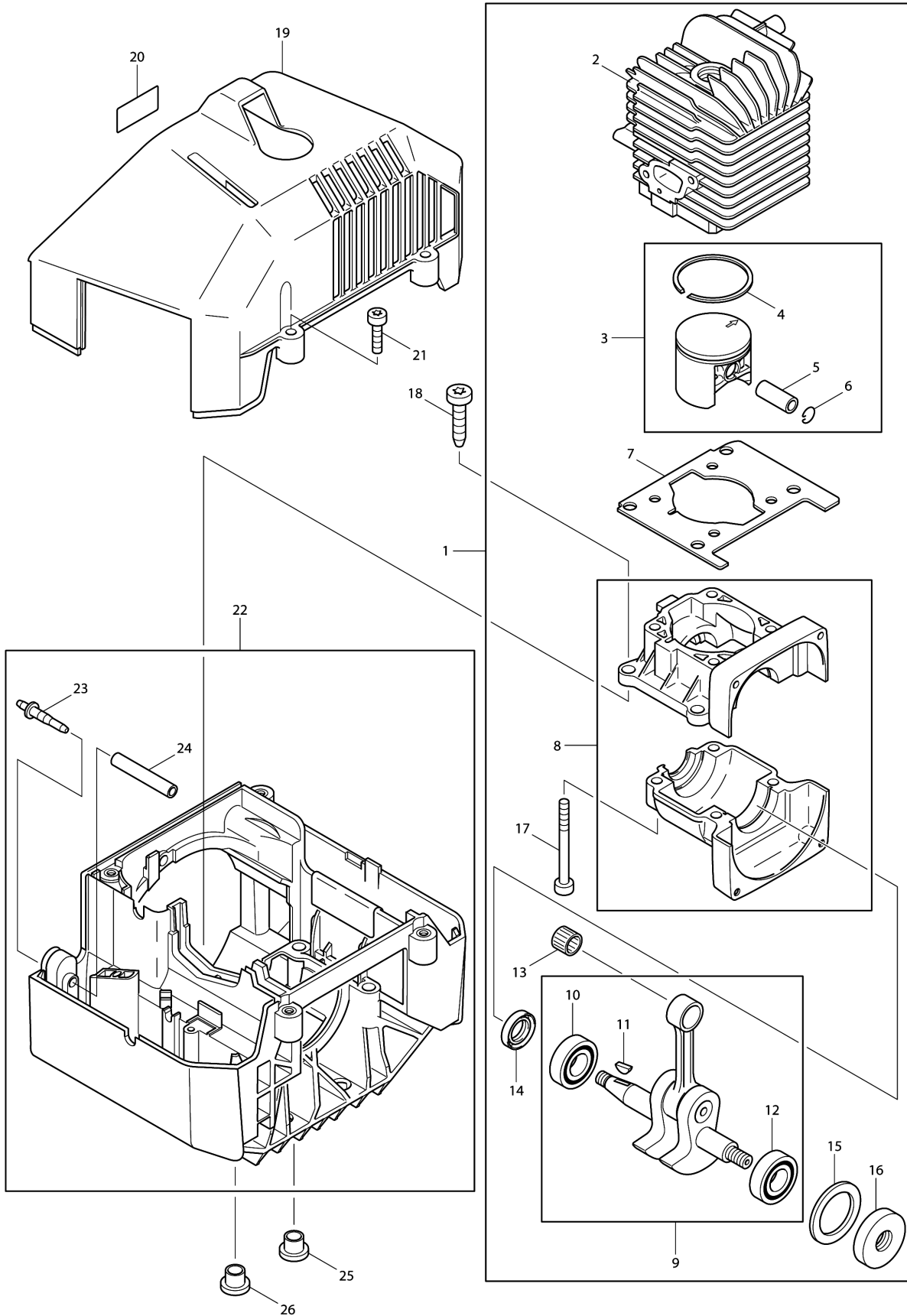

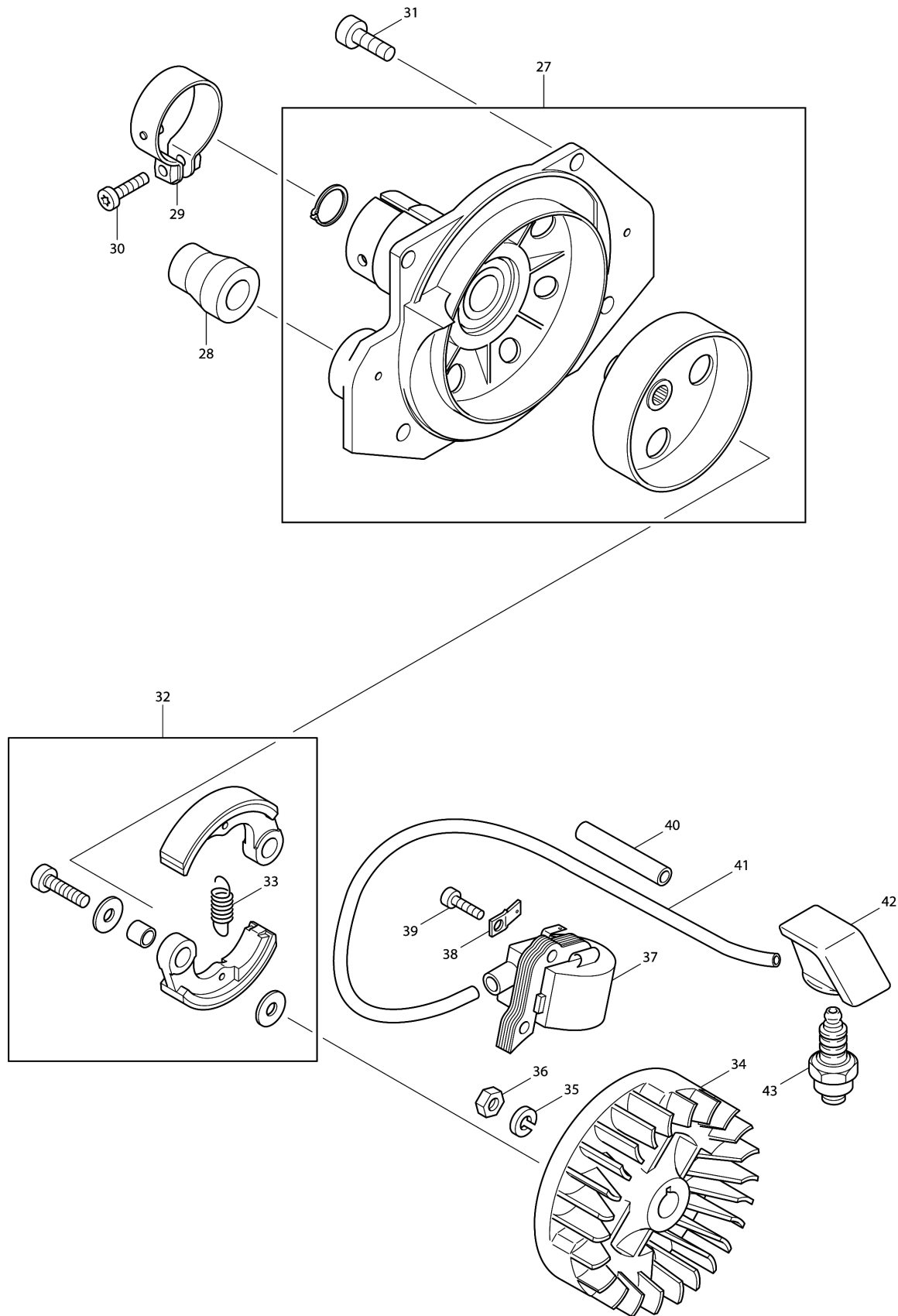

# Model No.DBC4010 BRUSH CUTTER





# Model No.DBC4010 BRUSH CUTTER

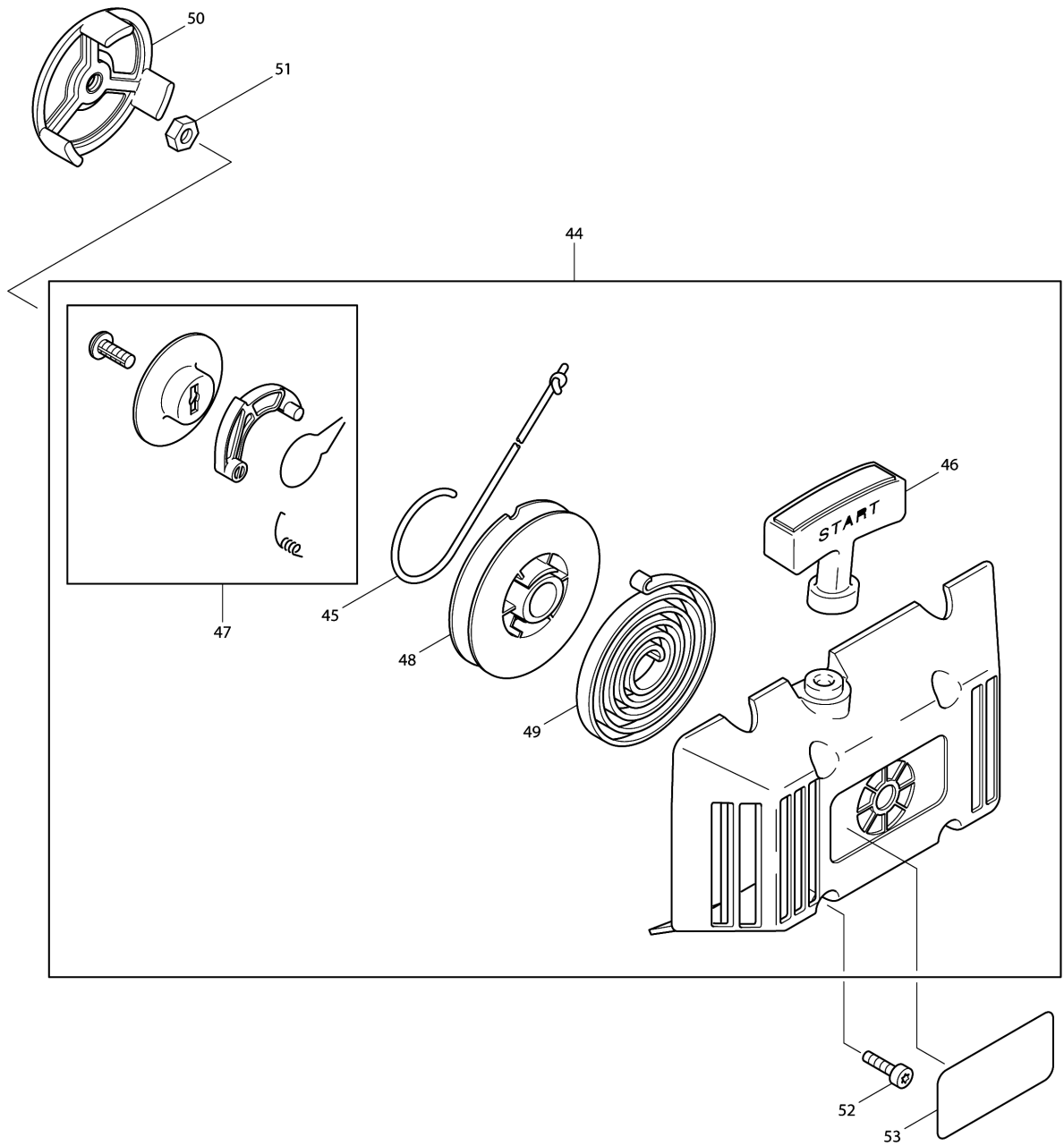



# Model No.DBC4010 BRUSH CUTTER

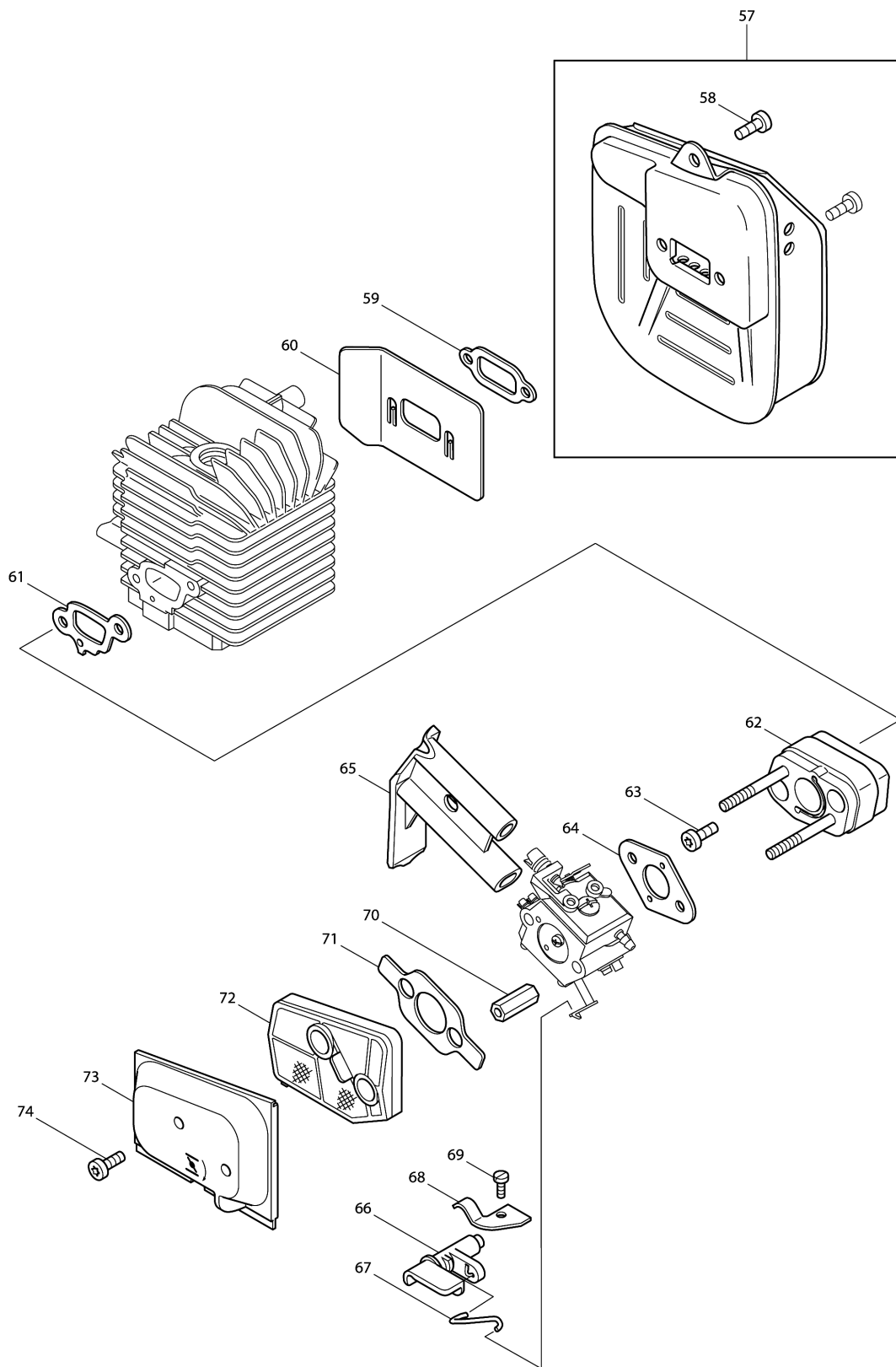





Model No.DBC4010 BRUSH CUTTER

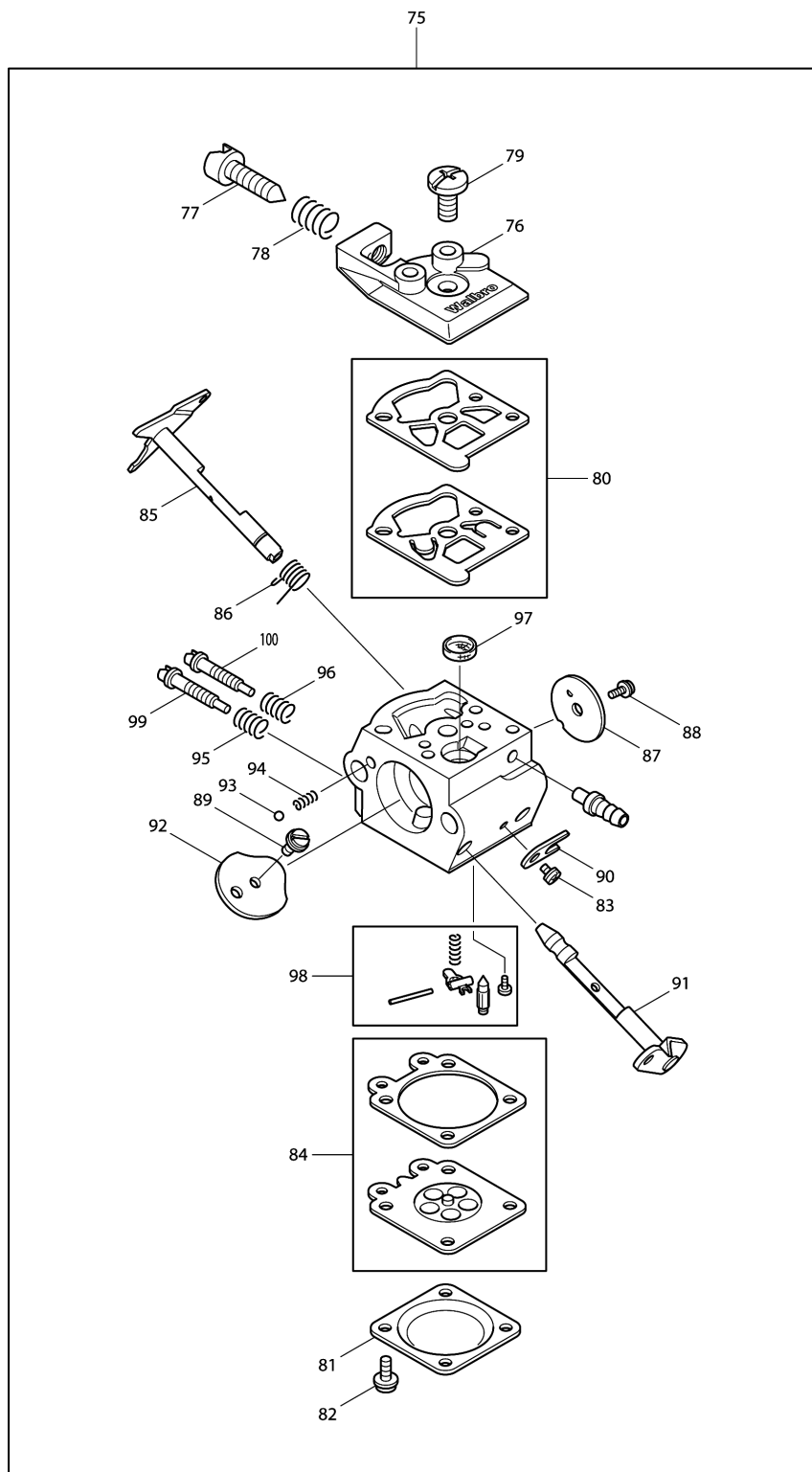



# Model No.DBC4010 BRUSH CUTTER

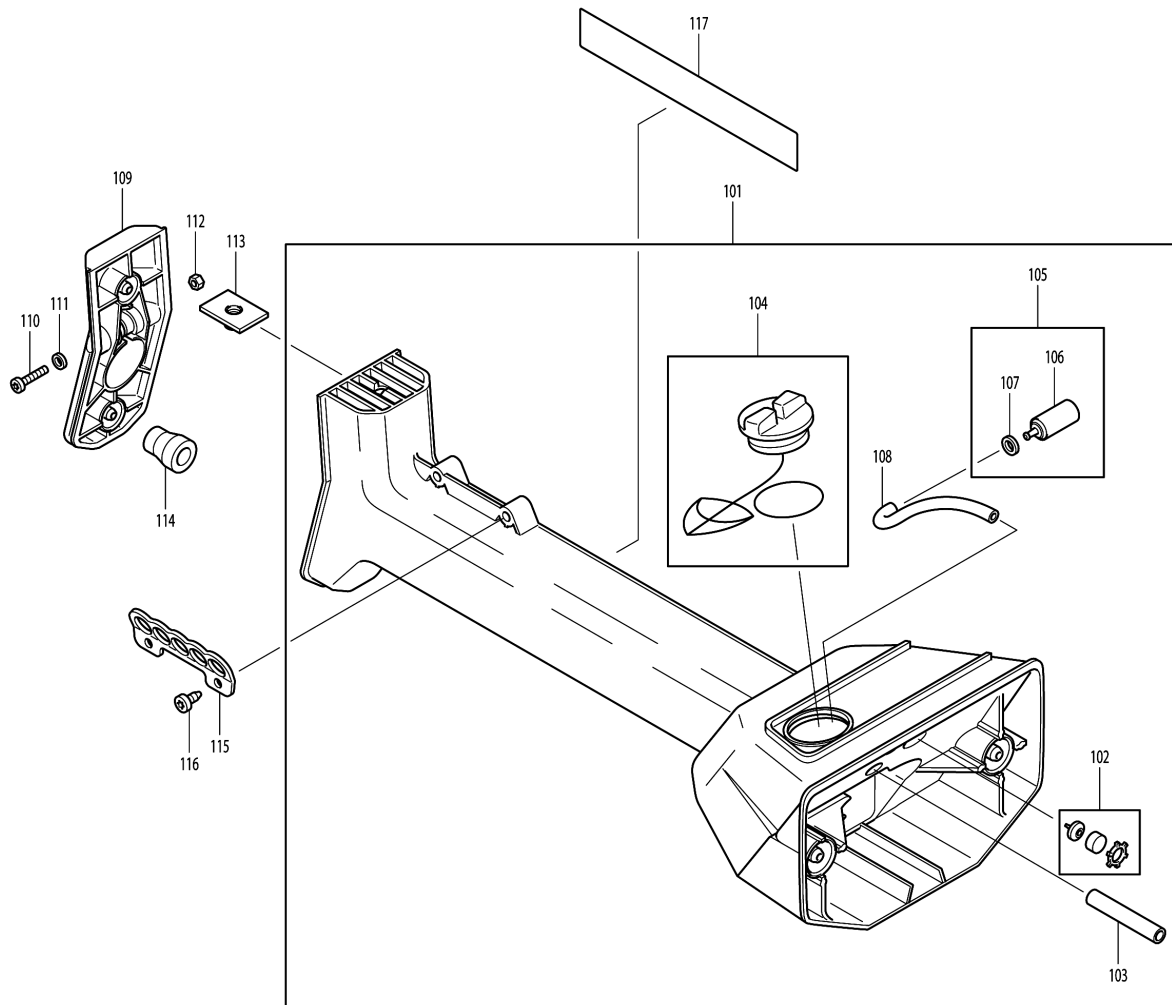



# Model No.DBC4010 BRUSH CUTTER

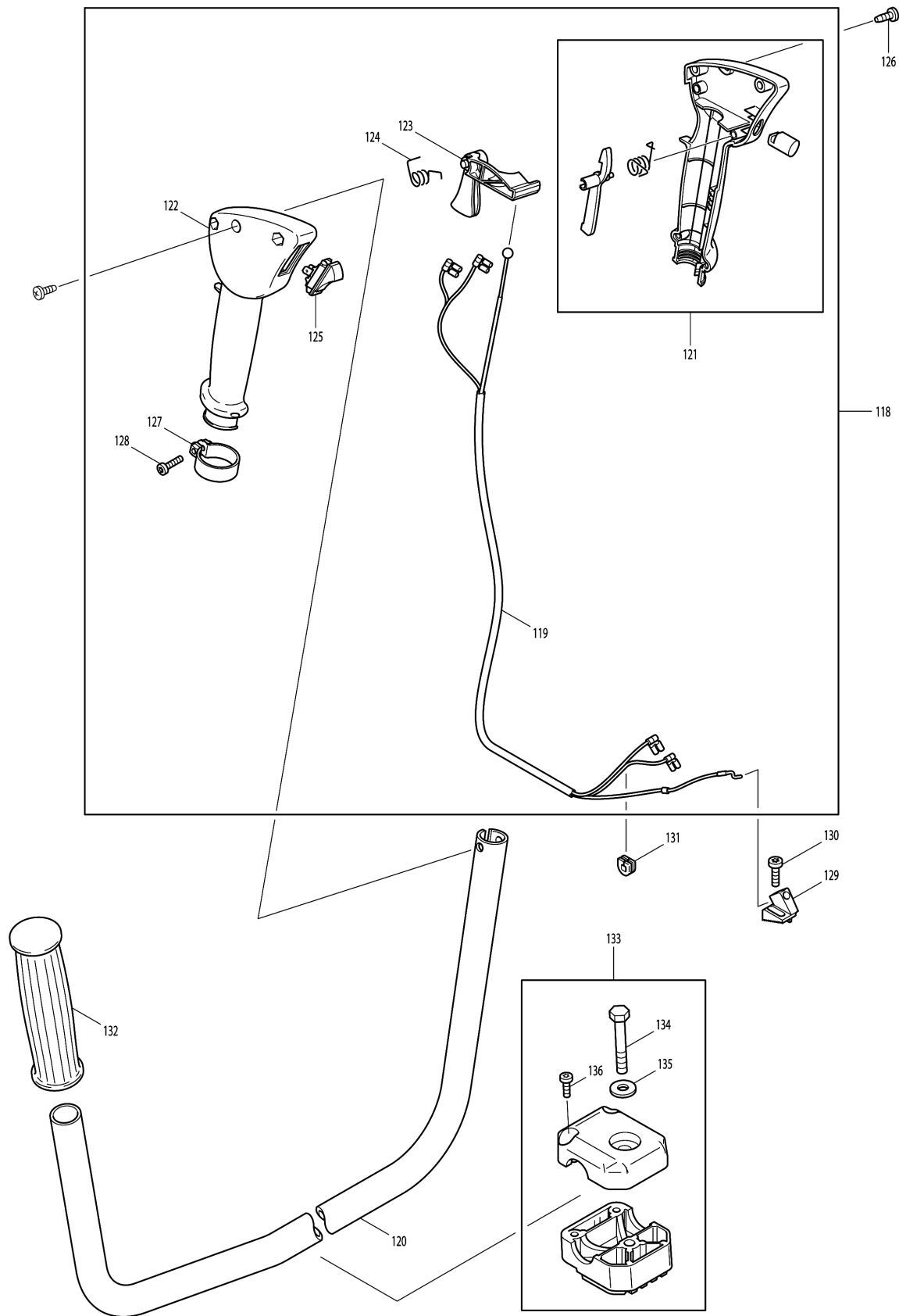



### Model No.DBC4010 BRUSH CUTTER

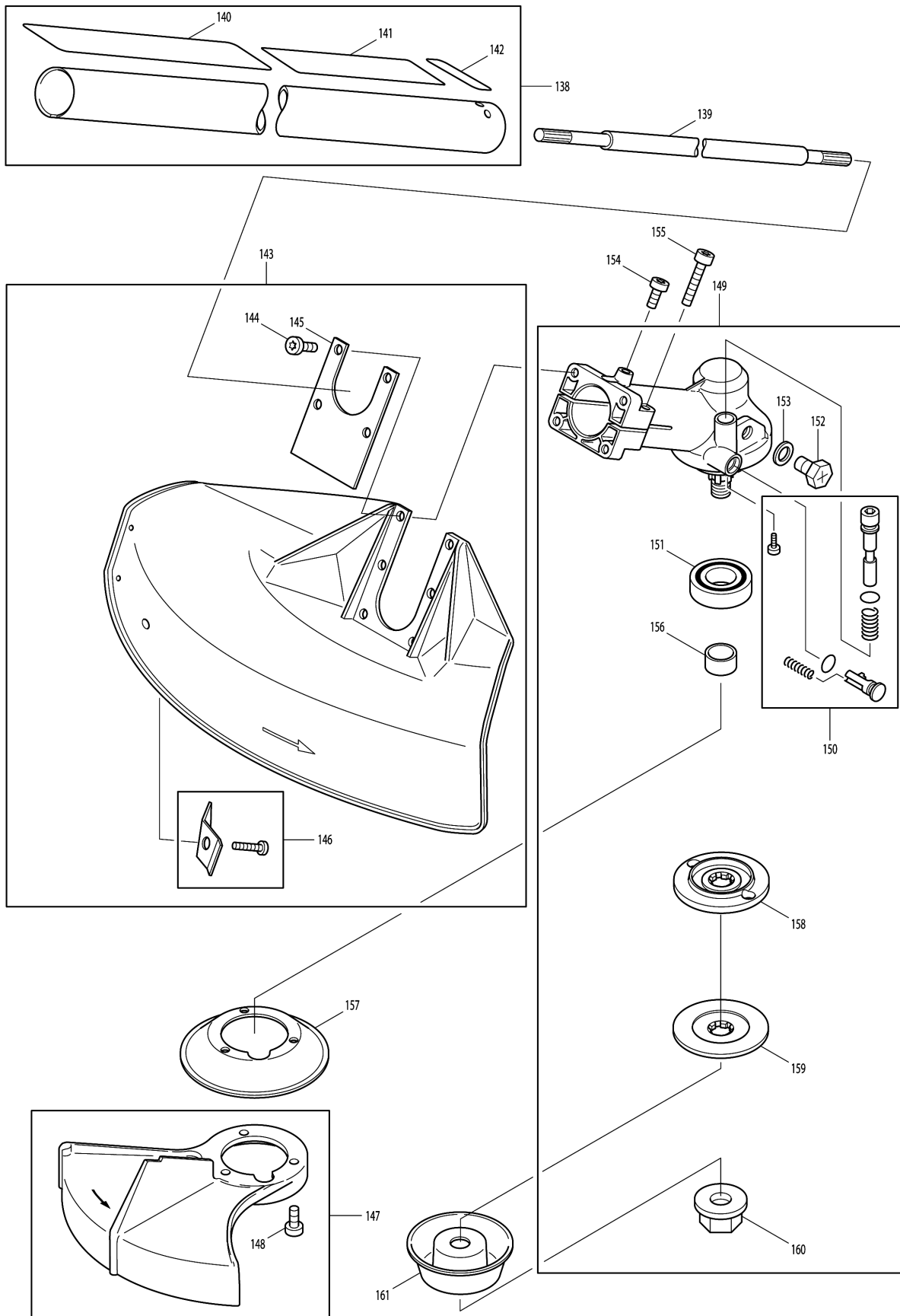





## Model No.DBC4010 BRUSH CUTTER

Item	Parts No.	Description	I/C	Qty	New/Old	Opt. 1	Opt. 2	Note
001	385100100	SHORT BLOCK 40ML		1				
D10		INC. 2,3,6-9,13-17						
002	385131011	CYLINDER 40ML		1				
003	385132000	PISTON ASSY 40MM		1				
D10		INC. 4,5						
004	021132230	PISTONRING(40MM)		1				
005	385132030	PISTON PIN		1				
006	385132040	SPRING RING		2				
007	965527010	GASKET		1				
008	385111100	CRANKCASE ASSY.		1				
009	385120100	CRANK SHAFT ASSY.		1				
D10		INC. 10-12						
010	960102129	BALLBEARING 6201		1				
011	939620371	KEY		1				
012	960102129	BALLBEARING 6201		1				
013	962211033	NEEDLE CAGE		1				
014	962900057	OIL SEAL 12		1				
015	900006217	DISC		1				
016	962900024	RADIAL RING		1				
017	908505555	H.L. SOCKET HEAD BOLT M5X55		4				
018	913467304	SCREW 6.7X30		4				
019	385118011	HOOD		1				
021	908605205	SCREW M5X20		4				
022	386110011	MOTOR HOUSING		1				
D10		INC. 23,24						
023	001131020	NIPPLE		1				
024	965452060	TUBE		1				
025	965404240	PLUG		1				
026	965404240	PLUG		1				
027	385217000	CLUTCH CASE ASSY		1				
028	965403380	RING BUFFER		2				
029	965903061	CLAMPING RING		1				
030	908006255	FILLISTER HEAD SCREW M6X25		1				
031	913467254	SCREW 6.7X25		4				
032	010181000	CLUTCH SHOE,SET		1				
D10		INC. 33						
033	385184020	SPRING		1				
034	385141011	FLYWHEEL		1				
035	928308001	SPRING WASHER 8X17		1				
036	920308024	HEX. NUT M8X1 (FINE THREAD)		1				
037	385143030	IGNITION COIL		1				

Please order the parts with part number.

Print Date 26/6/2019

## Model No.DBC4010 BRUSH CUTTER

Item	Parts No.	Description	I/C	Qty	New/Old	Opt. 1	Opt. 2	Note
038	965605411	PLUG		1				
039	908605205	SCREW M5X20		2				
040	970502110	INSULATING TUBE 6 L=1M		1				
041	970310200	IGNITION CABLE L=1M		1				
042	385147100	PLUG CAP WITH SPRING		1				
043	965603021	SPARK PLUG BPMR7A		1				
044	385160103	STARTER ASSY		1				
D10		INC. 45-49						
045	387164010	STARTER ROPE		1				
045A	985000150	STARTER ROPE 3.0MM L=100M		1				
046	957404691	STARTER GRIP CPL.		1				
047	957160385	STARTER REPAIR SET		1				
048	385162020	CABLE DRUM		1				
049	385163100	REWIND SPRING		1				
050	385166040	STARTER WHEEL		1				
051	920308024	HEX. NUT M8X1 (FINE THREAD)		1				
052	908605205	SCREW M5X20		1				
053	980114147	LABEL		1				
057	957174385	MUFFLER		1				
D10		INC. 58						
058	908405145	H.L. SOCKET HEAD BOLT M5X14		5				
059	965527040	GASKET		1				
060	385174011	COOLING PLATE		1				
061	965527030	GASKET		1				
062	385131071	INTERMEDIATE FLANGE, CPL.		1				
064	965527020	GASKET		1				
065	385154010	ADJUSTING GUIDE		1				
066	028150740	CHOKE LEVER		1				
067	385150030	CHOKE LINKAGE		1				
068	385150020	SPRING SHACKLE		1				
069	915135130	SCREW 3.5X13		1				
070	001173060	NUT		2				
071	965527060	GASKET		1				
072	385173100	AIR FILTER		1				
073	385118060	COOLING COVER		1				
074	908605145	H.L. SOCKET HEAD BOLT M5X14		2				
075	385151001	CARBURETOR CPL		1				
D10		INC. 76-100						
076	021151160	PUMP COVER		1				
077	001151400	IDLE STOP SCREW		1				

Please order the parts with part number.

Print Date 26/6/2019

## Model No.DBC4010 BRUSH CUTTER

Item	Parts No.	Description	I/C	Qty	New/Old	Opt. 1	Opt. 2	Note
078	021151230	PRESSURE SPRING		1				
079	118151190	SCREW		1				
080	957151010	PUMP DIAPHRAGM,SET		1				
081	021151120	DIAPHRAGM COVER		1				
082	118151020	SCREW		4				
083	118151020	SCREW		1				
084	957151020	CONTROL DIAPHRAGM,SET		1				
085	385151040	THROTTLE SHAFT		1				
086	371151310	SPRING		1				
087	001151680	THROTTLE SHUTTER		1				
088	118151060	SCREW		1				
089	118151060	SCREW		1				
090	108151350	SHAFT CLIP		1				
091	385151020	SHAFT ASSY. CHOKE		1				
092	001151350	CHOKE SHUTTER		1				
093	118151170	FRICTION BALL		1				
094	118151160	FRICTION SPRING		1				
095	021151530	SPRING(H)		1				
096	021151480	SPRING(L)		1				
097	021151180	SCREEN		1				
098	957150040	SET OF CONTROL PARTS		1				
099	001151420	MAIN ADJUSTMENT SCREW(H)		1				
100	001151410	IDLING ADJUSTMENT SCREW(L)		1				
101	385114611	TANK ASSY		1				
D10		INC. 102-105,108						
102	957114010	VENT VALVE ASSY.		1	*			
102-1	957114011	VENT VALVE ASSY.	O	1				
103	965452060	TUBE		1				
104	010114045	TANK PLUG CPL		1				
105	963601420	SUCTION HEAD CPL		1				
D10		INC. 106,107						
106	963601150	SUCTION HEAD		1				
107	928605500	DISC		1				
108	965452480	FUEL LINE		1				
109	385310631	CLAMPING PIECE		1				
110	908006305	FILLISTER HEAD SCREW M6X30		1				
111	924106400	WASHER M6		1				
112	920206000	HEXAGONAL NUT M6		1				
113	385365010	INSERTING PLATE		1				
114	965403380	RING BUFFER		2				
115	385316010	ORIFICE PLATE		1				

Please order the parts with part number.

Print Date 26/6/2019

## Model No.DBC4010 BRUSH CUTTER

Item	Parts No.	Description	I/C	Qty	New/Old	Opt. 1	Opt. 2	Note
116	913467164	SCREW 6.7X16		2				
117	980114672	LABEL DBC4010		1				
118	369313202	OPERATING LEVER ASSY.		1				
D10		INC. 119,121-125						
119	385726070	BOWDEN CABLE CPL.		1				
120	385310161	HANDLE		1				
121	369313290	HANDLE HALF,RIGHT,CPL		1				
122	369313080	HANDLE HALF,LEFT		1				
123	369311080	THROTTLE LEVER		1				
124	369311071	SPRING		1				
125	975001210	SHORT CIRCUIT SWITCH		1				
126	915735100	PZ2 TAPPING SCREW 3.5X9.5		2				
127	965903080	CLAMPING RING		1				
128	908006255	FILLISTER HEAD SCREW M6X25		1				
129	385176010	RETAINING CLIP		1				
130	913455204	H.L.TAPPING SCREW 5.5X20		1	*			
130-1	913455204	H.L.TAPPING SCREW 5.5X20	O	1				
131	965401018	RUBBER BUSH		1				
132	387311100	HANDLE, LEFT		1				
133	957310610	CLAMPING HOLDER SET		1				
D10		INC. 134-136						
134	900108555	HEXAGONAL SCREW M8X55		1				
135	924108400	DISC 8.4		1				
136	908005165	FILLISTER HEAD SCREW M5X16		2				
138	010261020	MAIN PIPE ASSY		1				
D10		INC. 140-142						
139	385228030	TRANSMISSION SHAFT		1				
140	980114628	LABEL		1				
141	980114148	LABEL		1				
142	980114119	LABEL		1				
143	010341612	PROTECTION HOOD ASSY		1				
D10		INC. 144-146						
144	908005165	FILLISTER HEAD SCREW M5X16		1				
145	385341021	PLATE		1				
146	957341010	LINE CUTTER		1				
147	010341630	PROTECTION HOOD CPL 200		1				
D10		INC. 148						
147A_	010341640	PROTECTION HOOD CPL 225		1				
D10		INC. 148						
148	908005125	H.L. SOCKET HEAD BOLT M5X12		3				

Please order the parts with part number.

Print Date 26/6/2019

## Model No.DBC4010 BRUSH CUTTER

Item	Parts No.	Description	I/C	Qty	New/Old	Opt. 1	Opt. 2	Note
149	385200203	BEVEL GEAR ASSY		1				
D10		INC. 150-153,156,158-160						
150	957385272	TOOL ROCKING SYST.CPL		1				
151	962900055	RADIAL RING		1				
152	900210104	HEXAGONAL HEAD SCREW M10X1.25		1				
153	963604084	GASKET		1				
154	908005125	H.L. SOCKET HEAD BOLT M5X12		1				
155	908005255	H.L. SOCKET HEAD BOLT M5X25		2				
156	385228020	DISTANCE RING		1				
157	385224410	WINDING PREVENTER		1				
158	385224012	MOUNTING DISC		1				
159	385224022	PRESSURE DISC		1				
160	385228041	SAFETY NUT M12X1.5L		1				
161	385218020	SLIDING CUP		1				

Please order the parts with part number.

Print Date 26/6/2019