

INSTRUCTION MANUAL

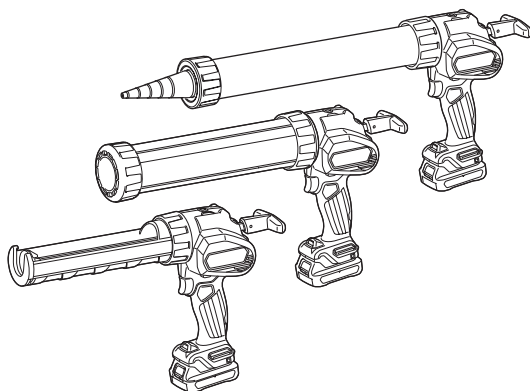

# Cordless Caulking Gun

## CG100D



Read before use.

# SPECIFICATIONS

<b>Model:</b>		<b>CG100D</b>
Maximum feed force		5,000 N
Feed speed		0 - 28 mm/s
Stroke	300 ml size holder	214 mm
	600 ml size holder	350 mm
	800 ml size holder	294 mm
Overall length	300ml size holder	404 mm
	600ml size holder	538 mm
	800ml size holder	480 mm
Rated voltage		D.C. 10.8 V - 12 V max
Standard battery cartridge		BL1015 / BL1016 / BL1020B / BL1021B / BL1040B / BL1041B
Charger		DC10SA / DC10SB / DC10WC / DC10WD
Net weight		1.9 - 2.6 kg

- Due to our continuing program of research and development, the specifications herein are subject to change without notice.
- Specifications and battery cartridge may differ from country to country.
- The weight may differ depending on the attachment(s), including the battery cartridge. The lightest and heaviest combinations, according to EPTA-Procedure 01/2014, are shown in the table.

## Symbols

The followings show the symbols used for the equipment. Be sure that you understand their meaning before use.



Read instruction manual.



Only for EU countries  
Do not dispose of electric equipment or battery pack together with household waste material!  
In observance of the European Directives, on Waste Electric and Electronic Equipment and Batteries and Accumulators and Waste Batteries and Accumulators and their implementation in accordance with national laws, electric equipment and batteries and battery pack(s) that have reached the end of their life must be collected separately and returned to an environmentally compatible recycling facility.

## Intended use

This tool is intended for applying caulking material to surface.

## Noise

The typical A-weighted noise level determined according to EN62841:

Sound pressure level ( $L_{pA}$ ): 70 dB(A) or less  
Uncertainty (K): 3 dB(A)

The noise level under working may exceed 80 dB (A).

**NOTE:** The declared noise emission value(s) has been measured in accordance with a standard test method and may be used for comparing one tool with another.

**NOTE:** The declared noise emission value(s) may also be used in a preliminary assessment of exposure.

**⚠ WARNING:** Wear ear protection.

**⚠ WARNING:** The noise emission during actual use of the power tool can differ from the declared value(s) depending on the ways in which the tool is used especially what kind of workpiece is processed.

**⚠ WARNING:** Be sure to identify safety measures to protect the operator that are based on an estimation of exposure in the actual conditions of use (taking account of all parts of the operating cycle such as the times when the tool is switched off and when it is running idle in addition to the trigger time).

## Vibration

The vibration total value (tri-axial vector sum) determined according to EN62841:

Work mode: operation without load  
Vibration emission ( $a_h$ ): 2.5 m/s<sup>2</sup> or less  
Uncertainty (K): 1.5 m/s<sup>2</sup>

**NOTE:** The declared vibration total value(s) has been measured in accordance with a standard test method and may be used for comparing one tool with another.

**NOTE:** The declared vibration total value(s) may also be used in a preliminary assessment of exposure.

**⚠ WARNING:** The vibration emission during actual use of the power tool can differ from the declared value(s) depending on the ways in which the tool is used especially what kind of workpiece is processed.

**⚠ WARNING:** Be sure to identify safety measures to protect the operator that are based on an estimation of exposure in the actual conditions of use (taking account of all parts of the operating cycle such as the times when the tool is switched off and when it is running idle in addition to the trigger time).

## EC Declaration of Conformity

### For European countries only

The EC declaration of conformity is included as Annex A to this instruction manual.

## SAFETY WARNINGS

### General power tool safety warnings

**⚠ WARNING:** Read all safety warnings, instructions, illustrations and specifications provided with this power tool. Failure to follow all instructions listed below may result in electric shock, fire and/or serious injury.

### Save all warnings and instructions for future reference.

The term "power tool" in the warnings refers to your mains-operated (corded) power tool or battery-operated (cordless) power tool.

#### Work area safety

1. **Keep work area clean and well lit.** Cluttered or dark areas invite accidents.
2. **Do not operate power tools in explosive atmospheres, such as in the presence of flammable liquids, gases or dust.** Power tools create sparks which may ignite the dust or fumes.
3. **Keep children and bystanders away while operating a power tool.** Distractions can cause you to lose control.

#### Electrical safety

1. **Power tool plugs must match the outlet. Never modify the plug in any way. Do not use any adapter plugs with earthed (grounded) power tools.** Unmodified plugs and matching outlets will reduce risk of electric shock.
2. **Avoid body contact with earthed or grounded surfaces, such as pipes, radiators, ranges and refrigerators.** There is an increased risk of electric shock if your body is earthed or grounded.
3. **Do not expose power tools to rain or wet conditions.** Water entering a power tool will increase the risk of electric shock.
4. **Do not abuse the cord. Never use the cord for carrying, pulling or unplugging the power tool. Keep cord away from heat, oil, sharp edges or moving parts.** Damaged or entangled cords increase the risk of electric shock.
5. **When operating a power tool outdoors, use an extension cord suitable for outdoor use.** Use of a cord suitable for outdoor use reduces the risk of electric shock.
6. **If operating a power tool in a damp location is unavoidable, use a residual current device (RCD) protected supply.** Use of an RCD reduces the risk of electric shock.
7. **Power tools can produce electromagnetic fields (EMF) that are not harmful to the user.** However, users of pacemakers and other similar medical devices should contact the maker of their device and/or doctor for advice before operating this power tool.

#### Personal safety

1. **Stay alert, watch what you are doing and use common sense when operating a power tool. Do not use a power tool while you are tired or under the influence of drugs, alcohol or medication.** A moment of inattention while operating power tools may result in serious personal injury.
2. **Use personal protective equipment. Always wear eye protection.** Protective equipment such as a dust mask, non-skid safety shoes, hard hat or hearing protection used for appropriate conditions will reduce personal injuries.
3. **Prevent unintentional starting. Ensure the switch is in the off-position before connecting to power source and/or battery pack, picking up or carrying the tool.** Carrying power tools with your finger on the switch or energising power tools that have the switch on invites accidents.
4. **Remove any adjusting key or wrench before turning the power tool on.** A wrench or a key left attached to a rotating part of the power tool may result in personal injury.
5. **Do not overreach. Keep proper footing and balance at all times.** This enables better control of the power tool in unexpected situations.
6. **Dress properly. Do not wear loose clothing or jewellery. Keep your hair and clothing away from moving parts.** Loose clothes, jewellery or long hair can be caught in moving parts.
7. **If devices are provided for the connection of dust extraction and collection facilities, ensure these are connected and properly used.** Use of dust collection can reduce dust-related hazards.
8. **Do not let familiarity gained from frequent use of tools allow you to become complacent and ignore tool safety principles.** A careless action can cause severe injury within a fraction of a second.
9. **Always wear protective goggles to protect your eyes from injury when using power tools. The goggles must comply with ANSI Z87.1 in the USA, EN 166 in Europe, or AS/NZS 1336 in Australia/New Zealand. In Australia/New Zealand, it is legally required to wear a face shield to protect your face, too.**

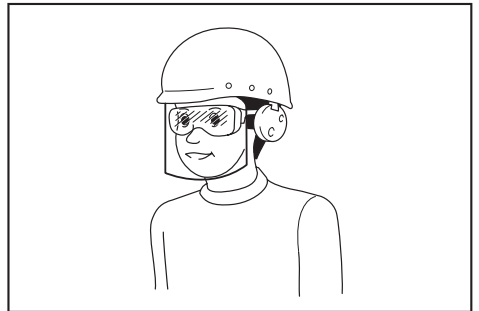

It is an employer's responsibility to enforce the use of appropriate safety protective equipments by the tool operators and by other persons in the immediate working area.

### Power tool use and care

1. **Do not force the power tool. Use the correct power tool for your application.** The correct power tool will do the job better and safer at the rate for which it was designed.
2. **Do not use the power tool if the switch does not turn it on and off.** Any power tool that cannot be controlled with the switch is dangerous and must be repaired.
3. **Disconnect the plug from the power source and/or remove the battery pack, if detachable, from the power tool before making any adjustments, changing accessories, or storing power tools.** Such preventive safety measures reduce the risk of starting the power tool accidentally.
4. **Store idle power tools out of the reach of children and do not allow persons unfamiliar with the power tool or these instructions to operate the power tool.** Power tools are dangerous in the hands of untrained users.
5. **Maintain power tools and accessories. Check for misalignment or binding of moving parts, breakage of parts and any other condition that may affect the power tool's operation. If damaged, have the power tool repaired before use.** Many accidents are caused by poorly maintained power tools.
6. **Keep cutting tools sharp and clean.** Properly maintained cutting tools with sharp cutting edges are less likely to bind and are easier to control.
7. **Use the power tool, accessories and tool bits etc. in accordance with these instructions, taking into account the working conditions and the work to be performed.** Use of the power tool for operations different from those intended could result in a hazardous situation.
8. **Keep handles and grasping surfaces dry, clean and free from oil and grease.** Slippery handles and grasping surfaces do not allow for safe handling and control of the tool in unexpected situations.
9. **When using the tool, do not wear cloth work gloves which may be entangled.** The entanglement of cloth work gloves in the moving parts may result in personal injury.

### Battery tool use and care

1. **Recharge only with the charger specified by the manufacturer.** A charger that is suitable for one type of battery pack may create a risk of fire when used with another battery pack.
2. **Use power tools only with specifically designated battery packs.** Use of any other battery packs may create a risk of injury and fire.
3. **When battery pack is not in use, keep it away from other metal objects, like paper clips, coins, keys, nails, screws or other small metal objects, that can make a connection from one terminal to another.** Shorting the battery terminals together may cause burns or a fire.
4. **Under abusive conditions, liquid may be ejected from the battery; avoid contact. If contact accidentally occurs, flush with water. If liquid contacts eyes, additionally seek medical help.** Liquid ejected from the battery may cause irritation or burns.

5. **Do not use a battery pack or tool that is damaged or modified.** Damaged or modified batteries may exhibit unpredictable behaviour resulting in fire, explosion or risk of injury.
6. **Do not expose a battery pack or tool to fire or excessive temperature.** Exposure to fire or temperature above 130 °C may cause explosion.
7. **Follow all charging instructions and do not charge the battery pack or tool outside the temperature range specified in the instructions.** Charging improperly or at temperatures outside the specified range may damage the battery and increase the risk of fire.

### Service

1. **Have your power tool serviced by a qualified repair person using only identical replacement parts.** This will ensure that the safety of the power tool is maintained.
2. **Never service damaged battery packs.** Service of battery packs should only be performed by the manufacturer or authorized service providers.
3. **Follow instruction for lubricating and changing accessories.**

## Cordless caulking gun safety warnings

1. Keep hands and clothes away from the rod and the plunger area. Otherwise your finger or clothes may be pinched.
2. Hold the tool firmly.
3. Always work in well ventilated area and wear proper protections in accordance with the operation.
4. Read and follow the manufacture's instructions on caulking material or adhesive material before usage.

## SAVE THESE INSTRUCTIONS.

**⚠WARNING: DO NOT let comfort or familiarity with product (gained from repeated use) replace strict adherence to safety rules for the subject product. MISUSE or failure to follow the safety rules stated in this instruction manual may cause serious personal injury.**

## Important safety instructions for battery cartridge

1. **Before using battery cartridge, read all instructions and cautionary markings on (1) battery charger, (2) battery, and (3) product using battery.**
2. **Do not disassemble battery cartridge.**
3. **If operating time has become excessively shorter, stop operating immediately. It may result in a risk of overheating, possible burns and even an explosion.**
4. **If electrolyte gets into your eyes, rinse them out with clear water and seek medical attention right away. It may result in loss of your eyesight.**

5. **Do not short the battery cartridge:**
  - (1) **Do not touch the terminals with any conductive material.**
  - (2) **Avoid storing battery cartridge in a container with other metal objects such as nails, coins, etc.**
  - (3) **Do not expose battery cartridge to water or rain.**

A battery short can cause a large current flow, overheating, possible burns and even a breakdown.

6. **Do not store the tool and battery cartridge in locations where the temperature may reach or exceed 50 °C (122 °F).**
7. **Do not incinerate the battery cartridge even if it is severely damaged or is completely worn out. The battery cartridge can explode in a fire.**
8. **Be careful not to drop or strike battery.**
9. **Do not use a damaged battery.**
10. **The contained lithium-ion batteries are subject to the Dangerous Goods Legislation requirements.** For commercial transports e.g. by third parties, forwarding agents, special requirement on packaging and labeling must be observed. For preparation of the item being shipped, consulting an expert for hazardous material is required. Please also observe possibly more detailed national regulations. Tape or mask off open contacts and pack up the battery in such a manner that it cannot move around in the packaging.
11. **When disposing the battery cartridge, remove it from the tool and dispose of it in a safe place. Follow your local regulations relating to disposal of battery.**
12. **Use the batteries only with the products specified by Makita.** Installing the batteries to non-compliant products may result in a fire, excessive heat, explosion, or leak of electrolyte.
13. **If the tool is not used for a long period of time, the battery must be removed from the tool.**

## SAVE THESE INSTRUCTIONS.

**⚠ CAUTION:** Only use genuine Makita batteries. Use of non-genuine Makita batteries, or batteries that have been altered, may result in the battery bursting causing fires, personal injury and damage. It will also void the Makita warranty for the Makita tool and charger.

## Tips for maintaining maximum battery life

1. **Charge the battery cartridge before completely discharged. Always stop tool operation and charge the battery cartridge when you notice less tool power.**
2. **Never recharge a fully charged battery cartridge. Overcharging shortens the battery service life.**
3. **Charge the battery cartridge with room temperature at 10 °C - 40 °C (50 °F - 104 °F). Let a hot battery cartridge cool down before charging it.**

## FUNCTIONAL DESCRIPTION

**⚠ CAUTION:** Always be sure that the tool is switched off and the battery cartridge is removed before adjusting or checking function on the tool.

## Installing or removing battery cartridge

**⚠ CAUTION:** Always switch off the tool before installing or removing of the battery cartridge.

**⚠ CAUTION:** Hold the tool and the battery cartridge firmly when installing or removing battery cartridge. Failure to hold the tool and the battery cartridge firmly may cause them to slip off your hands and result in damage to the tool and battery cartridge and a personal injury.

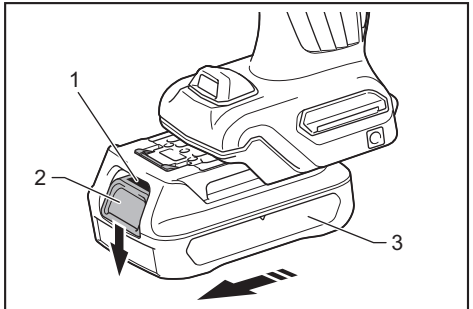

► 1. Red indicator 2. Button 3. Battery cartridge

To remove the battery cartridge, slide it from the tool while sliding the button on the front of the cartridge.

To install the battery cartridge, align the tongue on the battery cartridge with the groove in the housing and slip it into place. Insert it all the way until it locks in place with a little click. If you can see the red indicator on the upper side of the button, it is not locked completely.

**⚠ CAUTION:** Always install the battery cartridge fully until the red indicator cannot be seen. If not, it may accidentally fall out of the tool, causing injury to you or someone around you.

**⚠ CAUTION:** Do not install the battery cartridge forcibly. If the cartridge does not slide in easily, it is not being inserted correctly.

## Battery protection system

The tool is equipped with a battery protection system. This system automatically cuts off power to the motor to extend battery life.

The tool will automatically stop during operation if the tool and/or battery are placed under one of the following conditions:

### Overloaded:

The tool is operated in a manner that causes it to draw an abnormally high current.

In this situation, turn the tool off and stop the application that caused the tool to become overloaded. Then turn the tool on to restart.

If the tool does not start, the battery is overheated. In this situation, let the battery cool before turning the tool on again.

### Low battery voltage:

The remaining battery capacity is too low and the tool will not operate. If you turn the tool on, the motor runs again but stops soon. In this situation, remove and recharge the battery.

## Indicating the remaining battery capacity

Only for battery cartridges with the indicator

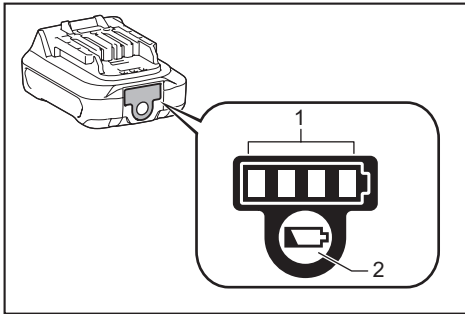

► 1. Indicator lamps 2. Check button

Press the check button on the battery cartridge to indicate the remaining battery capacity. The indicator lamps light up for a few seconds.

Indicator lamps		Remaining capacity
Lighted	Off	
■ ■ ■ ■	□	75% to 100%
■ ■ ■ □	□	50% to 75%
■ ■ □ □	□ □	25% to 50%
■ □ □ □	□ □ □ □	0% to 25%

**NOTE:** Depending on the conditions of use and the ambient temperature, the indication may differ slightly from the actual capacity.

## Switch action

**⚠ WARNING:** Before installing the battery cartridge into the tool, always check to see that the switch trigger actuates properly and returns to the "OFF" position when released.

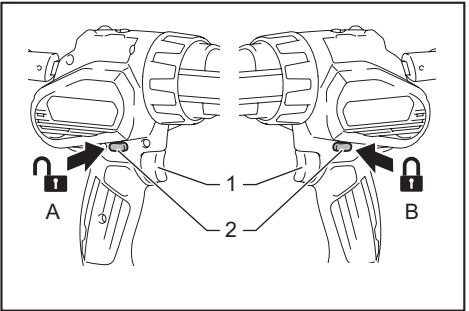

► 1. Switch trigger 2. Trigger-lock button

To prevent the switch trigger from accidentally pulled, the trigger-lock button is provided.

To start the tool, depress the trigger-lock button from A side and pull the switch trigger. Tool speed is increased by increasing pressure on the switch trigger. Release the switch trigger to stop.

After use, press in the trigger-lock button from B side.

## Speed adjusting dial

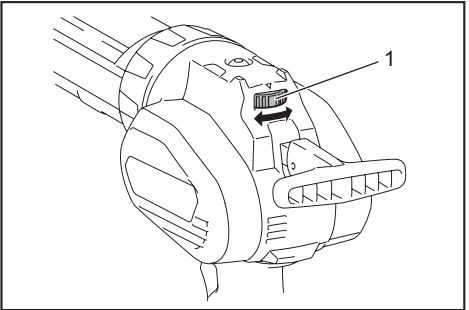

► 1. Speed adjusting dial

The tool speed can be adjusted by turning the speed adjusting dial. You can get the highest speed at 5 and the lowest speed at 1.

**NOTICE:** Do not turn the dial quickly when the tool is working.

**NOTICE:** Depending on the type and conditions of caulking material, it may not be fed at low speed. In this case, set the speed adjusting dial higher.

**NOTICE:** When changing the speed dial from "5" to "1", turn the dial counterclockwise. Do not turn the dial clockwise forcibly.

## Lighting up the front lamp

**CAUTION:** Do not look in the light or see the source of light directly.

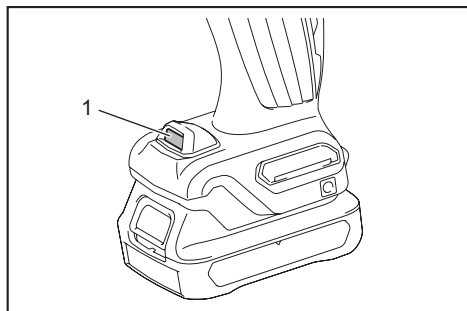

► 1. Lamp

To turn on the lamp, slightly pull the switch trigger, and then release it. The lamp goes out approximately 10 seconds after releasing the switch trigger.

**NOTICE:** When the tool is overheated, the lamp flickers. Cool down the tool fully before operating the tool again.

**NOTE:** Use a dry cloth to wipe the dirt off the lens of the lamp. Be careful not to scratch the lens of lamp, or it may lower the illumination.

## Overload warning lamp

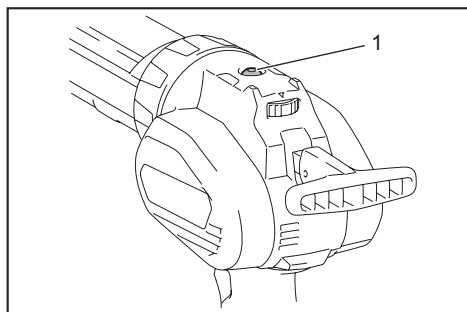

► 1. Warning lamp

The warning lamp blinks when the tool is highly loaded. If the load increases and the tool becomes overloaded, the tool stops automatically and the warning lamp keeps on lighting. In this case, release the switch trigger, and remove the cause of overload, and then restart the tool.

**NOTE:** When the warning lamp blinks, check the following points:

- The caulking material is clogged.
- The speed adjusting dial is set to high speed.
- The cutting area of the tip of the cartridge nozzle or film type package is too small.

## Drip preventive function

The motor keeps running for a short time even after the trigger is released. It releases the pressure of the caulking material and prevents dripping.

## ASSEMBLY

**CAUTION:** Always be sure that the tool is switched off and the battery cartridge is removed before carrying out any work on the tool.

## Installing or removing 300 ml size holder

### Installing or removing the holder joint

Attach the holder joint and plate by securing the screws firmly. To remove the holder joint, follow the installation procedure in reverse.

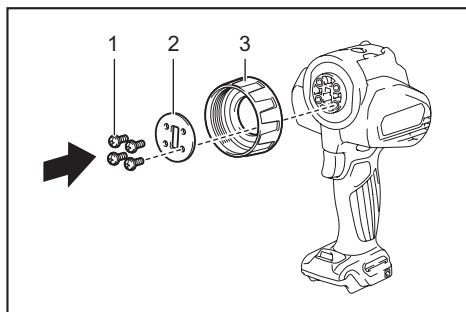

► 1. Screw 2. Plate 3. Holder joint

### Installing or removing the rod and piston

1. Insert the rod from the rear side of the tool with its teeth facing down.

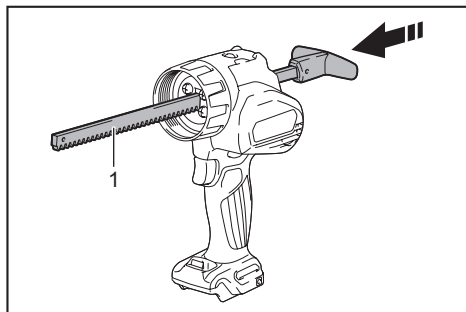

► 1. Short rod

2. Attach piston A with the screw.

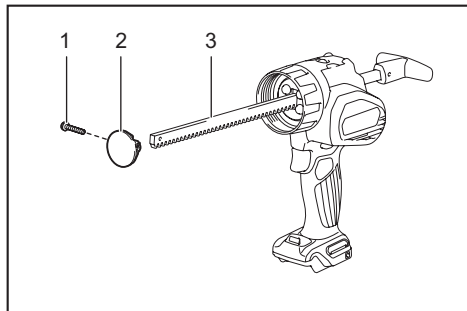

- 1. Screw 2. Piston A 3. Short rod

**NOTICE:** Available type of caulking material container for 300 ml size holder is cartridge only. Be sure to attach piston A to the rod.

To remove the rod and piston, follow the installation procedure in reverse.

### Installing or removing the holder

**CAUTION:** Secure the holder to the holder joint firmly. Otherwise the holder may come off during operation and may cause an injury.

To install the holder, turn it clockwise firmly until it stops while holding the holder joint. To remove the holder, follow the installation procedure in reverse.

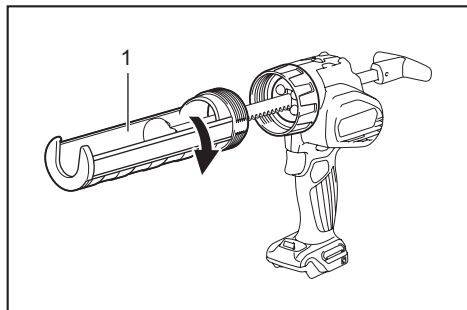

- 1. Holder

## Installing or removing 600 ml or 800 ml size holder

### Installing or removing the holder joint

Attach the holder joint and plate by securing the screws firmly. To remove the holder joint, follow the installation procedure in reverse.

For 600 ml size holder

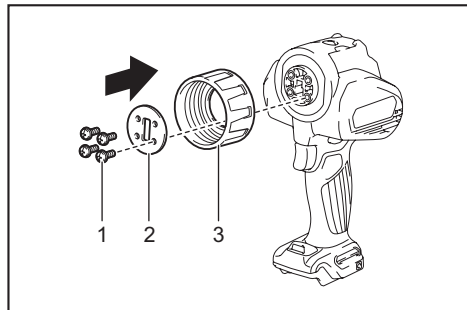

- 1. Screw 2. Plate 3. Holder joint

For 800 ml size holder

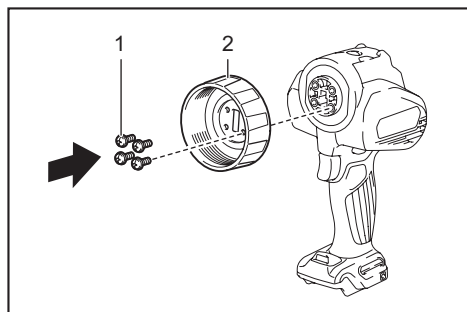





- 1. Screw 2. Holder joint and plate



## Selecting the type of piston

Select the proper type of piston according to the caulking material container by referring to the following table.

	600 ml size holder	800 ml size holder
Cartridge	Piston A 	Piston D 
Film package	Piston B 	Piston E* 
Direct filling	Piston C 	-

\*. Optional accessory

## Installing or removing the rod and piston

1. Insert the rod from the rear side of the tool with its teeth facing down.

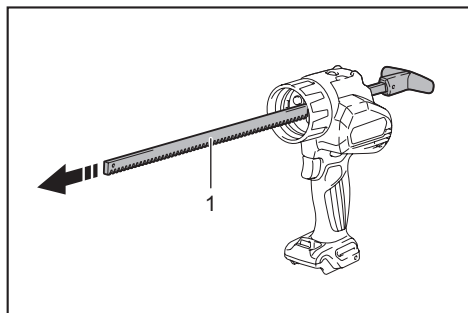

- 1. Long rod or black rod

**NOTICE:** For 600 ml size holder, use the long rod. For 800 ml size holder, use the black rod.

2. Attach the piston with the screw.

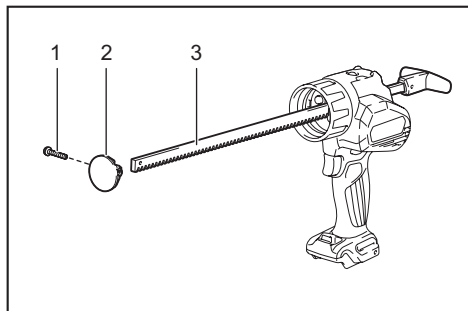

- 1. Screw 2. Piston 3. Long rod or black rod

To remove the rod and piston, follow the installation procedure in reverse.

## Installing or removing 600 ml or 800 ml size holder

**CAUTION:** Secure the holder to the holder joint firmly. Otherwise the holder may come off during operation and may cause an injury.

To install the holder, turn it clockwise until it stops while holding the holder joint.

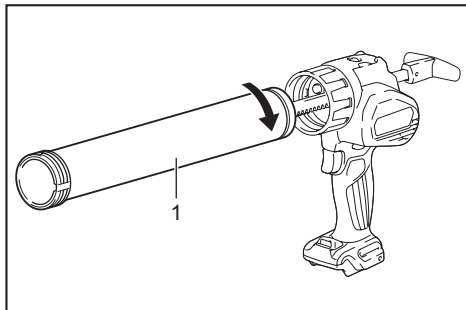

- 1. Holder

To remove the holder, follow the installation procedure in reverse.

## OPERATION

### Using cartridge

#### Preparing cartridge for use

1. Cut the tip of the cartridge nozzle so that the suitable amount of caulking material is fed.

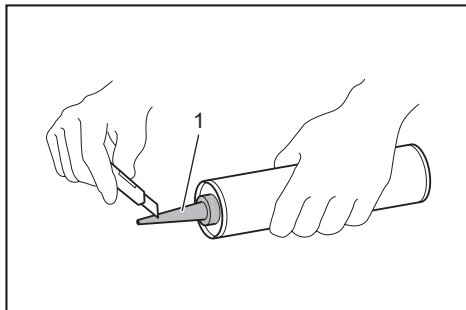

- 1. Nozzle

2. Make a hole on the protective film with the tip of the nozzle.

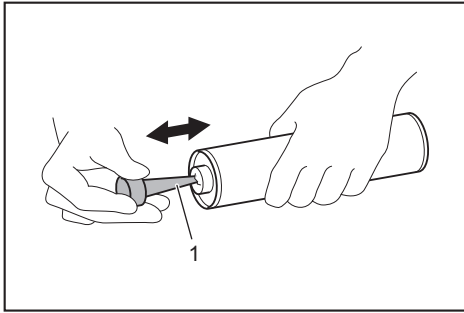

- 1. Nozzle

3. Attach the nozzle to the cartridge.

**NOTICE:** Be sure to check the cartridge for damage before installation. Using the damaged cartridge may cause malfunction.

**NOTICE:** When reusing the partially used cartridge, be sure to remove the solid caulking material before the installation.

### Installing cartridge to 300 ml size holder

**NOTICE:** Make sure that piston A is attached to the rod. Do not use other type of piston for cartridge.

1. Pull the rod handle backward slowly until it stops.

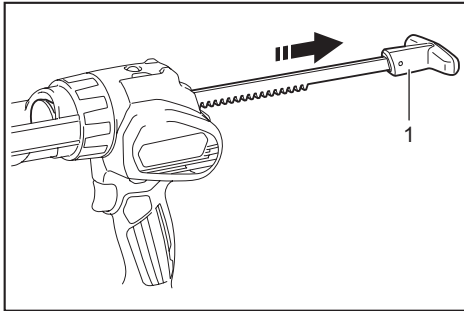

- 1. Rod handle

2. Insert the cartridge into the holder as shown in the figure.

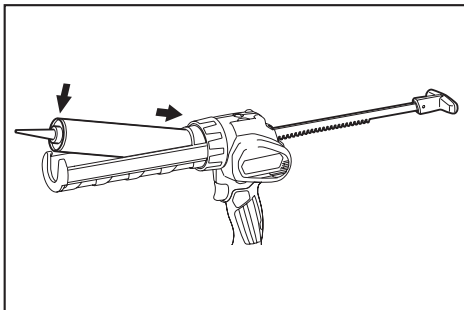

3. Push the rod gently until the piston touches the bottom of cartridge.

To remove the cartridge, follow the installation procedure in reverse.

### Installing cartridge to 600 ml or 800 ml size holder

**NOTICE:** Make sure that piston A (for 600 ml size holder) or piston D (for 800 ml size holder) is attached to the rod. Do not use other type of piston for cartridge.

1. Remove the holder cap from the holder, and then pull the rod handle backward slowly until it stops.

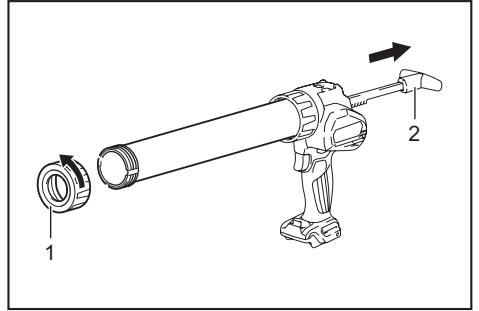

- 1. Holder cap 2. Rod handle

2. Insert the cartridge into the holder.

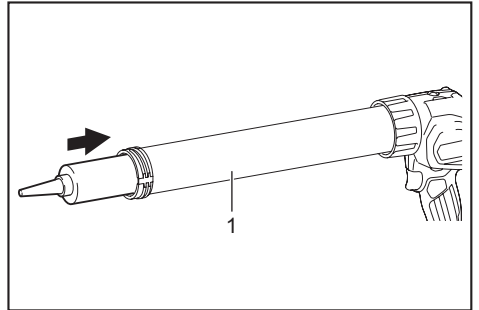

- 1. Holder

3. Attach the holder cap by turning it firmly while holding the holder.

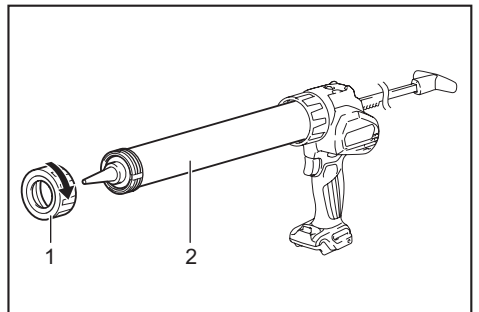

- 1. Holder cap 2. Holder

4. Push the rod gently until the piston touches the bottom of cartridge.

To remove the cartridge, follow the installation procedure in reverse.

## Using film type package

### Preparing package for use

Cut off the tip of the package.

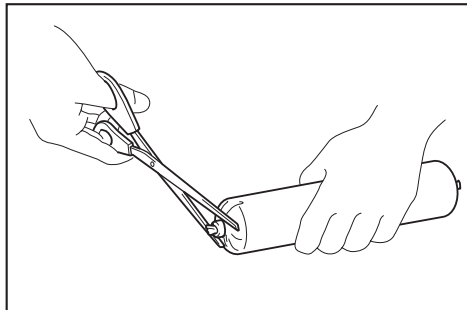

**NOTICE:** Be sure to check the package for damage before installation. Using the damaged package may cause malfunction.

### Installing film type package to 600 ml or 800 ml size holder

**NOTICE:** Make sure that piston B (for 600 ml size holder) or piston E (for 800 ml size holder) is attached to the rod. Do not use other type of piston for film type package.

1. Remove the holder cap, nozzle, and rubber ring from the holder.

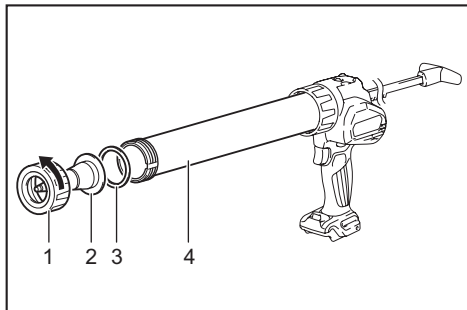

- ▶ 1. Holder cap 2. Nozzle 3. Rubber ring 4. Holder
2. Pull the rod handle backward slowly until it stops.

3. Insert the package into the holder.

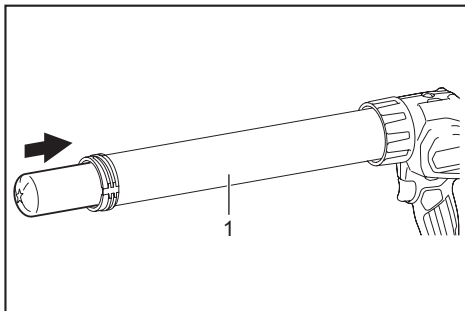

- ▶ 1. Holder

4. Attach the rubber ring, nozzle, and holder cap by turning the holder cap firmly.

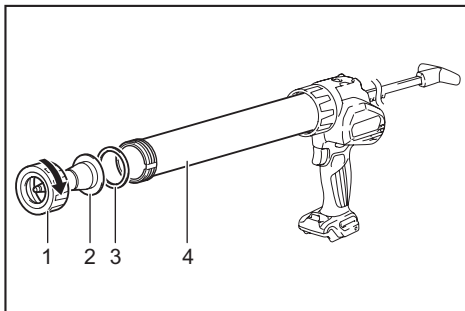

- ▶ 1. Holder cap 2. Nozzle 3. Rubber ring 4. Holder

5. Push the rod gently until the piston touches the package.

To remove the package, remove the holder cap, nozzle, rubber ring, and then push the rod handle forward until it stops.

## Direct filling

**NOTICE:** Make sure that 600 ml size holder is attached to the holder joint and piston C is attached to the rod. Do not use other type of holder and piston for direct filling.

1. Remove the holder cap, nozzle, and rubber ring from the holder.

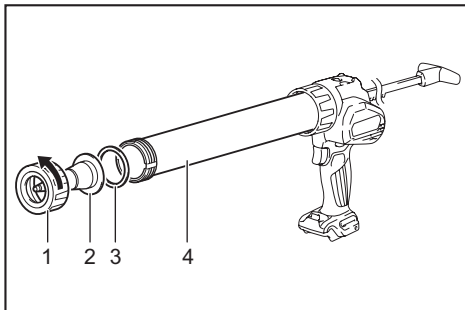

- ▶ 1. Holder cap 2. Nozzle 3. Rubber ring 4. Holder

2. Push the rod handle all the way until it stops.

3. Insert the tip of the holder into the caulking material, and then pull the rod handle slowly to fill the holder with the caulking material.

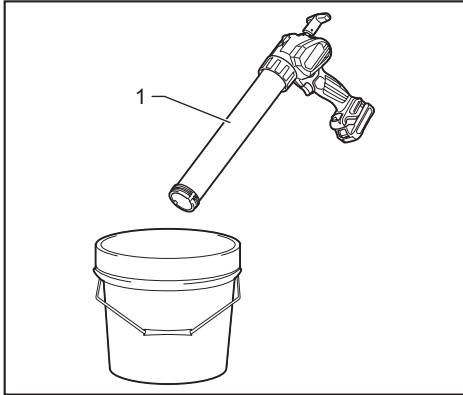

► 1. Holder

4. Attach the rubber ring, nozzle, and holder cap by turning the holder cap firmly.

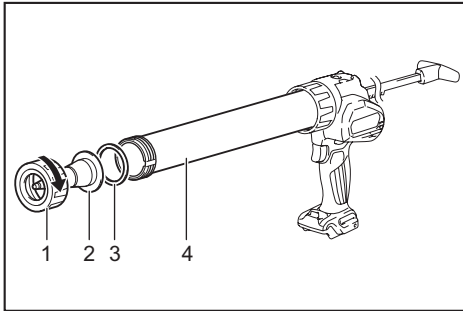

► 1. Holder cap 2. Nozzle 3. Rubber ring 4. Holder

## Caulking operation

Pull the trigger to feed the caulking material. Put one hand under the holder to support the tool while operating it.

After the operation, wipe off the caulking material from the tool. Be sure to remove the caulking material before it becomes solid.

**NOTE:** At the beginning of operation, set the speed adjusting dial to "1" and pull the switch trigger slowly to check how much amount of caulking material is fed.

**NOTE:** Depending on the type and conditions of caulking material, it may not be fed at low speed. In this case, set the speed adjusting dial higher.

**NOTE:** If the caulking material is not fed, check the following points:

- The tip of cartridge nozzle is not cut adequately.
- The caulking material is solid and clogged in the nozzle.
- The cartridge or package is damaged.
- The caulking material is stiff. Warm the material until it becomes soft.
- The attached piston is not appropriate for the type of caulking material.

## MAINTENANCE

**CAUTION:** Always be sure that the tool is switched off and the battery cartridge is removed before attempting to perform inspection or maintenance.

**NOTICE:** Never use gasoline, benzine, thinner, alcohol or the like. Discoloration, deformation or cracks may result.

To maintain product SAFETY and RELIABILITY, repairs, any other maintenance or adjustment should be performed by Makita Authorized or Factory Service Centers, always using Makita replacement parts.

## OPTIONAL ACCESSORIES

**CAUTION:** These accessories or attachments are recommended for use with your Makita tool specified in this manual. The use of any other accessories or attachments might present a risk of injury to persons. Only use accessory or attachment for its stated purpose.

If you need any assistance for more details regarding these accessories, ask your local Makita Service Center.

- Piston A
- Piston B
- Piston C
- Piston D
- Piston E
- 300ml size holder set
- 600ml size holder set
- 800ml size holder set
- Nozzle (for 600 ml size holder)
- Nozzle (for 800 ml size holder)
- Safety goggles
- Makita genuine battery and charger

**NOTE:** Some items in the list may be included in the tool package as standard accessories. They may differ from country to country.







**Makita Europe N.V.** Jan-Baptist Vinkstraat 2,  
3070 Kortenberg, Belgium

**Makita Corporation** 3-11-8, Sumiyoshi-cho,  
Anjo, Aichi 446-8502 Japan

[www.makita.com](http://www.makita.com)

885602A227 EN 20190425
------------------------------