

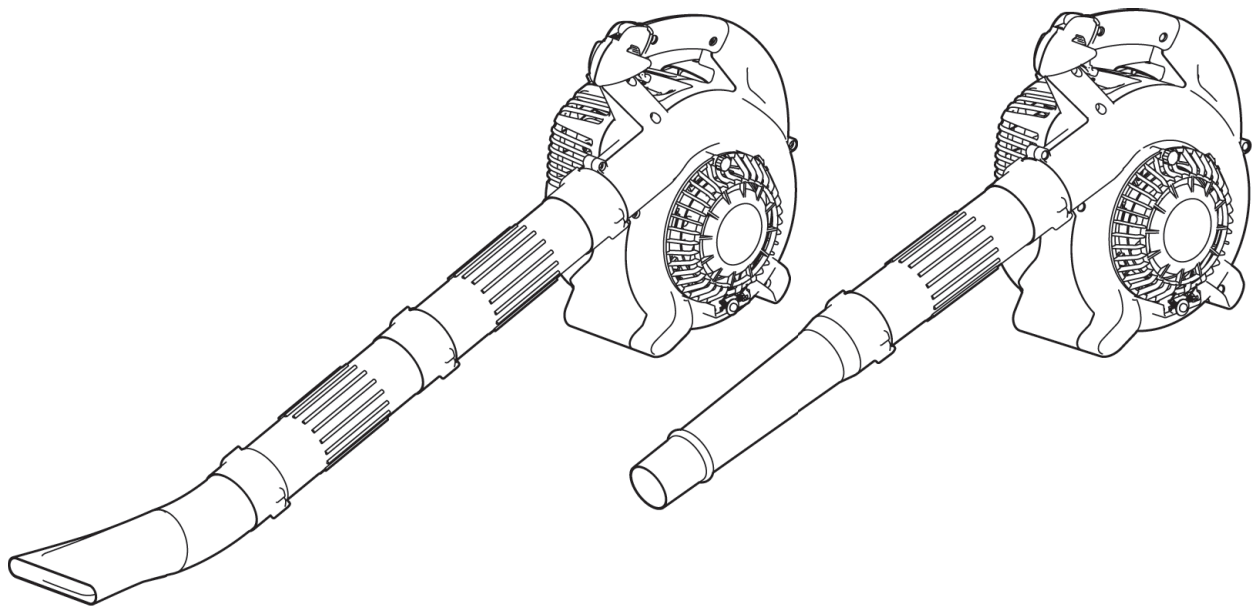

PETROL BLOWER

BHX2500



INSTRUCTION MANUAL

Important:

Read this instruction manual carefully before putting the Blower into operation and strictly observe the safety regulations! Preserve instruction manual carefully!

Thank you very much for selecting the MAKITA blower. We are pleased to be able to offer you the MAKITA blower which is the result of a long development programme and many years of knowledge and experience.

The blower models BHX2500 combines the advantages of state-of-the-art technology with ergonomic design. They are of light weight, handy, compact and represent professional equipment for a great variety of applications.

Please read, understand and follow this booklet which refers in detail to the various points that will demonstrate its outstanding performance. This will assist you to safely obtain the best possible results from your MAKITA Blower.



Table of contents

	Page
SYMBOLS.....	2
SAFETY INSTRUCTIONS	3
TECHNICAL DATA	6
DESIGNATION OF PARTS	7
ASSEMBLY INSTRUCTIONS	8
BEFORE START OF OPERATION	9
OPERATION	11
ADJUSTMENT OF IDLING.....	12
OPERATION METHOD.....	13
INSPECTION AND MAINTENANCE	15
STORAGE.....	17
TROUBLESHOOTING	19

SYMBOLS

It is very important to understand the following symbols when reading this instructions manual.

	WARNING/DANGER		Fuel (Gasoline)
	Read, Understand and Follow Instruction Manual		Engine-manual Start
	Forbidden		Emergency Stop
	No Smoking		First Aid
	No Open Flame		Recycling
	Protective Gloves must be Worn		
	Keep the Area of Operation Clear of All Persons and Pets		ON/START
	Wear Eye and Ear Protection		OFF/STOP
			Severing of fingers or hand, impeller blade

SAFETY INSTRUCTIONS

General Instructions

- To ensure correct and safe operation, the user must read, understand and follow this instruction manual to assure familiarity with the handling of the blower (1). Users insufficiently informed will risk danger to themselves as well as others due to improper handling.
- It is recommended only to loan the blower to people who have proven to be experienced with blowers.
- Always hand over the instruction manual.
- First-time users should ask the dealer for basic instructions to familiarize oneself with the handling of a blower.
- Children and young persons aged under 18 years must not be allowed to operate the blower. Persons over the age of 16 years may however use the tool for the purpose of being trained only while under the direct supervision of a qualified trainer.
- Use blowers with the utmost care and attention.
- Operate the blower only if you are in good physical condition.
- Perform all work conscientiously and carefully. The user has to accept responsibility for others.
- Never use the blower while under the influence of alcohol or drugs (2).
- Do not use the unit when you are tired.
- Save these instructions for future referral.

Personal Protective Equipment

- The clothing worn should be functional and appropriate, i. e. It should be tight-fitting but not cause a hindrance. Do not wear jewelry, clothing or long hair which could be drawn into the air intake.
- In order to avoid head-, eye-, hand- or foot injuries as well as to protect your hearing the following protective equipment and protective clothing must be used during operation of the blower.

Pay particular attention to the following regulations

- Clothing must be sturdy and snug-fitting, but allow complete freedom of movement. Avoid loose-fitting jackets, flared or cuffed pants, scarf, unconfined long hair or anything that could be drawn into the air intake. Wear overalls or long pants to protect your legs. Do not wear shorts. (4)
- Blower noise may damage your hearing. Wear sound barriers (ear plugs or ear muffs) to protect your hearing. Continual and regular users should have their hearing checked regularly. (3)
- Use of gloves when working with the blower is recommended. Good footing is most important. Wear sturdy shoes with non slip soles. (4)
- Proper eye protection is a must. Even though the discharge is directed away from the operator, ricochets and bounce backs can occur during blower operation. (3)
- Never operate a blower unless wearing goggles or properly fitted safety glasses with adequate top and side protection which comply with ANSI Z 87. 1 (or your applicable national standard).

Starting up the blower

- Please make sure that there are no children or other people within a working range of 15 meters (5), also pay attention to any animals in the working vicinity. Never use the blower in urban areas.
- Before operating, always check that the blower is safe for operation: Check the security of the throttle lever. The throttle lever should be checked for smooth and easy action. Check for proper functioning of the throttle lever lock. Check for clean and dry handles and test the function of the I-O switch. Keep handles free of oil and fuel.

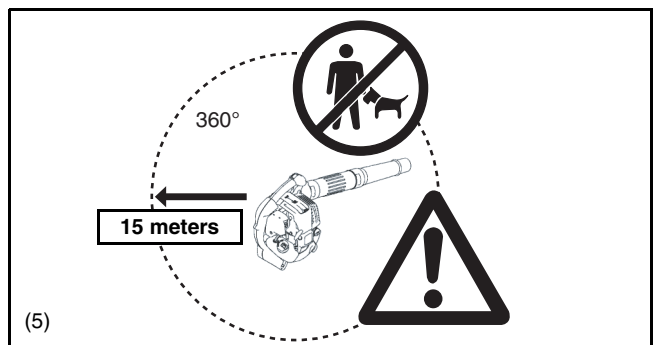
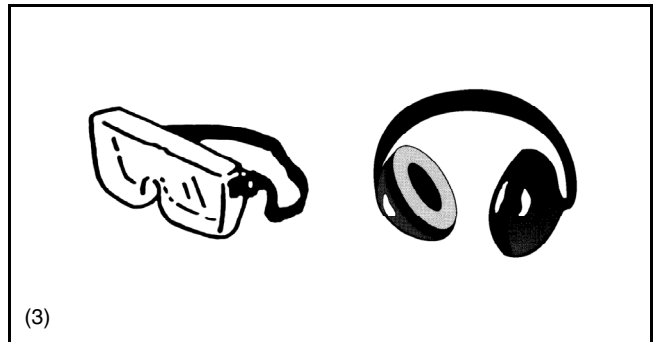
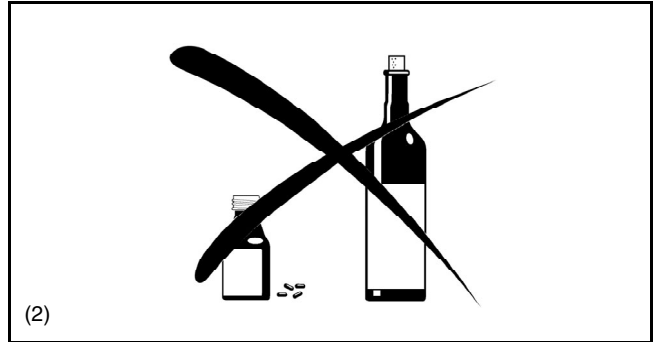
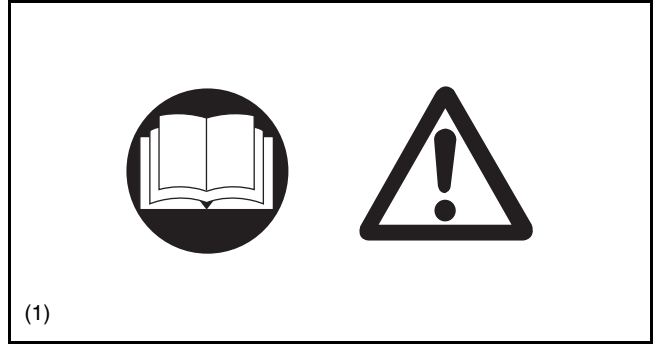

Start the Blower only in accordance with the instructions.
Do not use any other methods for starting the engine (6) !

- Use the blower and the tools supplied only for applications specified.
- Start the blower engine only after the entire tool has been assembled. Operation of the tool is permitted only after all the appropriate accessories are attached.
- The engine is to be switched off immediately if there are any engine problems.
- When working with the blower, always wrap your fingers tightly around the handle, keeping the control handle cradled between your thumb and forefinger. Keep your hand in this position to have your machine under control at all times. Make sure your control handle (and grip for vacuum attachment) are in good condition and free of moisture, pitch, oil or grease.

Always ensure a safe, well-balanced footing.

- Operate the blower in such a manner as to avoid inhalation of the exhaust gases. Never run the engine in enclosed rooms (risk of suffocation and gas poisoning). Carbon monoxide is an odorless gas. Always ensure there is adequate ventilation.
- Switch off the engine when resting and when leaving the blower unattended. Place it in a safe location prevent danger to others, setting fire to combustible materials, or damage to the machine.
- Never lay the hot blower onto dry grass or onto any combustible materials.
- All protective parts and guards supplied with the machine must be used during operation.
- Never operate the engine with a faulty exhaust muffler.
- Shut off the engine during transport (7).
- Position the blower safely during car or truck transportation to avoid fuel leakage.
- When transporting the blower, ensure that the fuel tank is completely empty.

Refuelling

- Shut off the engine during refuelling (7), keep well away from open flame (8) and do not smoke.
- Avoid skin contact with petroleum products. Do not inhale fuel vapor. Always wear protective gloves during refuelling. Change and clean protective clothing at regular intervals.
- Take care not to spill either fuel or oil in order to prevent soil contamination (environmental protection). Clean the blower immediately after fuel has been spilt. Allow wet cloths to dry before disposing in properly covered container to prevent spontaneous combustion.
- Avoid any fuel contact with your clothing. Change your clothing immediately if fuel has been spilled on it (fire hazard).
- Inspect the fuel cap at regular intervals making sure that it stays securely fastened.
- Carefully tighten the locking screw of the fuel tank. Change locations to start the engine (at least 3 meters away from the place of refuelling) (9).
- Never refuel in closed rooms. Fuel vapors accumulate at ground level (risk of explosions)
- Only transport and store fuel in approved containers. Make sure stored fuel is not accessible to children.
- Do not attempt to refuel a hot or a running engine.

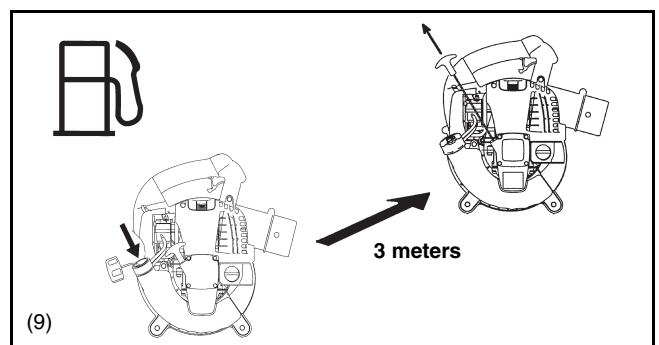
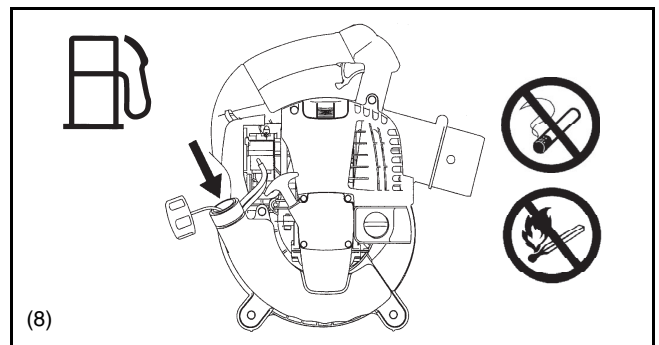
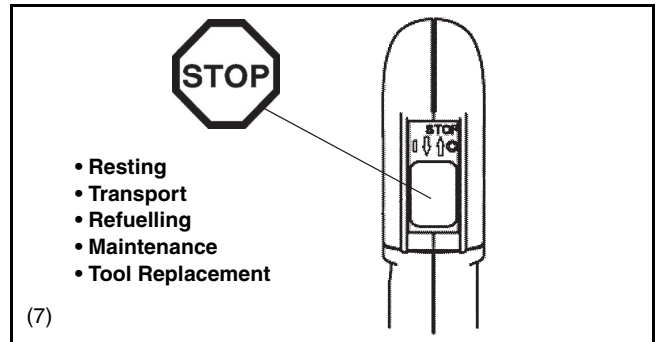
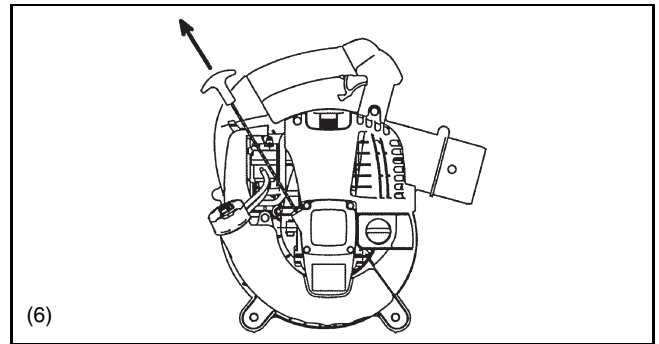

Method of operation

- Use the blower only in good light and visibility. During cold seasons beware of slippery or wet areas, ice and snow (risk of slipping). Always ensure a safe footing.
- Never work on unstable surfaces or steep terrain.
- To reduce the risk of personal injury, do not direct air blast towards bystanders, since the high pressure of the air flow could injure eyes and could blow small objects at great speed.
- Never insert any foreign object into the air intake of the machine or into the nozzle of the blower. It will damage the fan wheel and may cause serious injury to the operator or bystanders as a result of the object or broken parts being thrown out at high speed.
- Pay attention to the direction of the wind, i.e., do not work against the wind.
- To reduce the risk of stumbling and loss of control, do not walk backward while operating the machine.
- Always shut off the engine before cleaning or servicing the unit or replacing parts.

Maintenance instructions

- Be kind to the environment. Operate the blower with as little noise and pollution as possible. In particular check the correct adjustment of the carburetor.
- Clean the blower at regular intervals and check that all screws and nuts are securely tightened.
- Never service or store the blower in the vicinity of open flames, sparks, etc. (11).
- Always store the blower in a well-ventilated locked room and with an emptied fuel tank.

Observe and follow all relevant accident prevention instructions issued by the trade associations and by insurance companies. Do not perform any modifications to the blower as this will risk your safety.

The performance of maintenance or repair work by the user is limited to those activities as described in this instruction manual. All other work is to be done by Authorized Service Agents.

Use only genuine spare parts and accessories supplied by MAKITA. Use of non-approved accessories and tools means increased risk of accidents and injuries. MAKITA will not accept any liability for accidents or damage caused by the use of any non-approved attachment or accessories.

First Aid

In case of accident make sure that a well-stocked first-aid kit is available in the vicinity of the operations. Immediately replace any item taken from the first aid kit.

When asking for help, please give the following information:

- Place of accident
- What happened
- Number of injured persons
- Extent of injuries
- Your name

Packaging

The MAKITA blower is delivered in a protective cardboard box to prevent shipping damage. Cardboard is a basic raw material and is therefore consequently reusable or suitable for recycling (waste paper recycling).

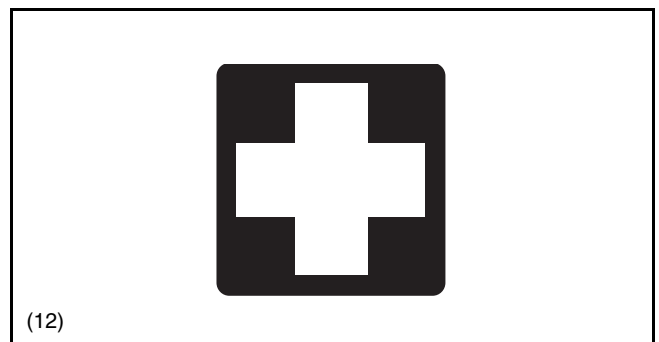
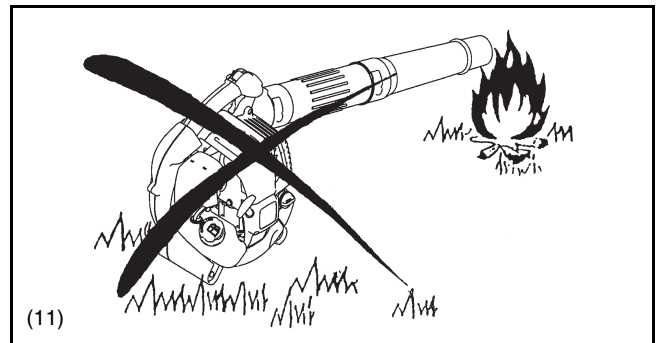

TECHNICAL DATA

Model		BHX2500
Mass (without blower pipe)	(kg)	4.5
Dimension (without blower pipe L x W x H)	(mm)	350×231×368
Max. engine speed	(min ⁻¹)	7,800
Idling speed	(min ⁻¹)	3,500
Engine displacement	(mL)	24.5
Fuel		Automobile gasoline
Fuel tank capacity	(L)	0.52
Engine oil		SAE 10W-30 oil of API Classification, Class SF or higher (4-stroke engine for automobile)
Engine oil volume	(L)	0.08
Carburetor (Diaphragm-carburetor)		WALBRO WYL
Ignition system		Solid state ignition
Spark plug		NGK CMR6A
Electrode gap	(mm)	0.7 - 0.8

Notes:

1. Use the oil and spark plug specified by MAKITA.
2. This specification is subject to change without prior notice.

DESIGNATION OF PARTS

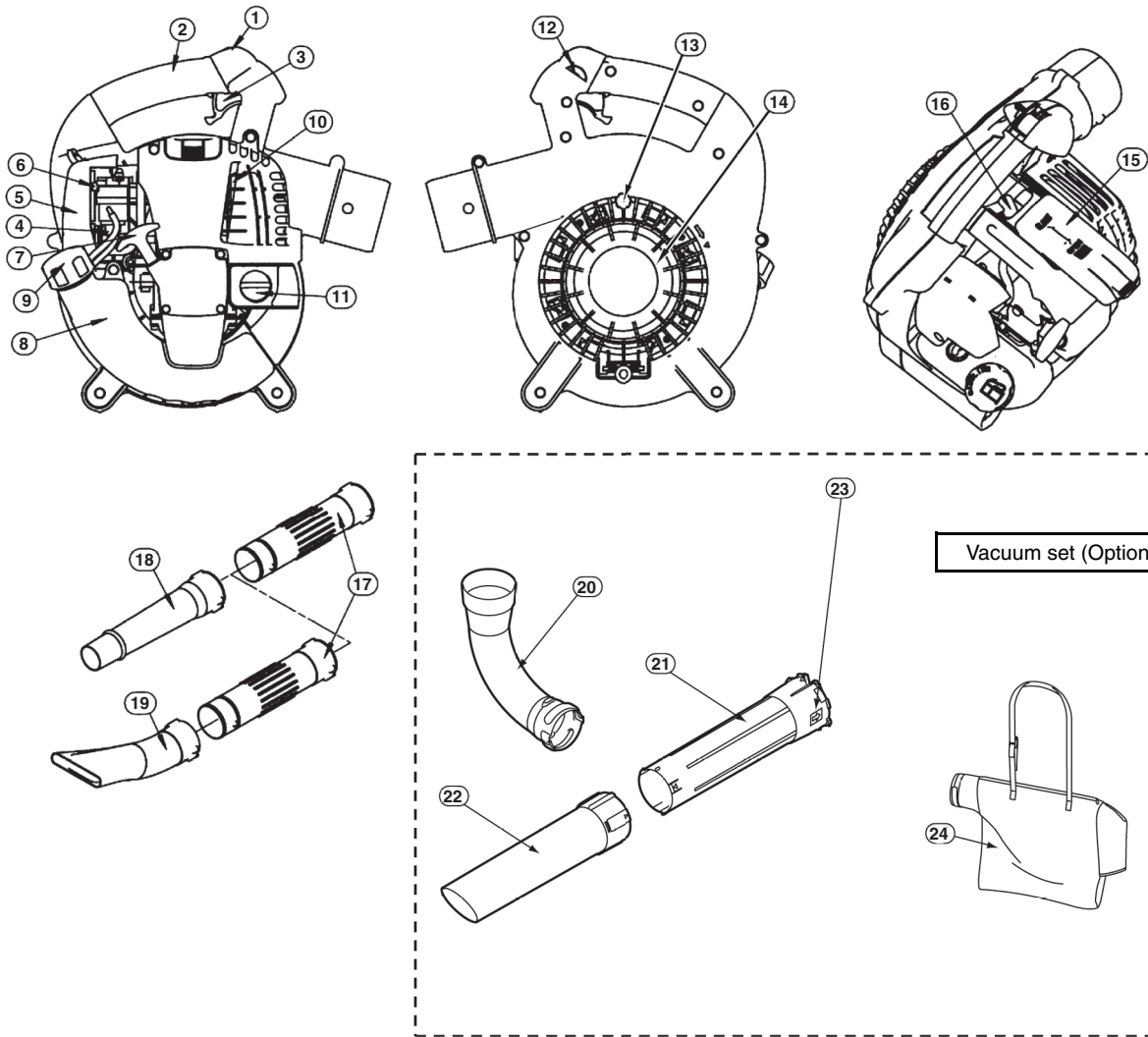

DESIGNATION OF PARTS	DESIGNATION OF PARTS	DESIGNATION OF PARTS	DESIGNATION OF PARTS
1. Stop switch	8. Fuel Tank /Assist Handle	15. Plug Cover	22. Vacuum Pipe B
2. Main Handle	9. Fuel Tank Cap	16. Spark Plug	23. Arrow Mark
3. Trigger Lever	10. Muffler	17. Blower Tube	24. Dust Bag
4. Primer Pump	11. Oil Cap	18. Blower Nozzle A	
5. Air Cleaner Cover	12. Cruise Control Lever	19. Blower Nozzle B	
6. Choke Lever	13. Screw	20. Elbow	
7. Starter Handle	14. Protector	21. Vacuum Pipe A	

Note:

- Either blower nozzle A or B is included as a standard accessory.
- Standard accessories may differ from country to country.

ASSEMBLY INSTRUCTIONS



CAUTION : Before performing any work on the blower, always stop the engine and pull the spark plug connectors off the spark plug.

Always wear protective gloves!

CAUTION : Start the blower only after having assembled it completely.

1. ASSEMBLY OF BLOWER PIPES

- 1) Align grooves in the blower pipe with pegs on the blower housing and slide the pipe onto housing.
- 2) Turn the blower pipe clockwise to lock it into place.
- 3) Place clamp ① around the opening of the blower pipe. Fasten securely with bolt ② and nut ③.

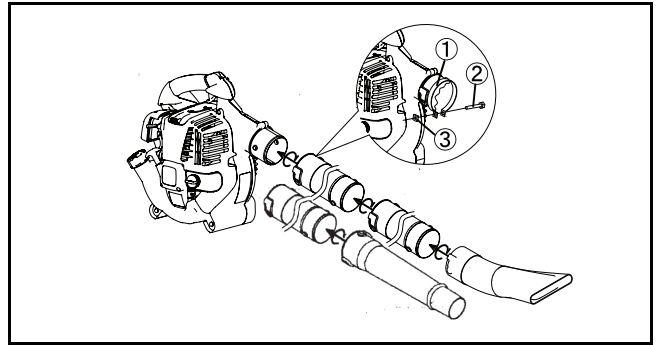

2. ASSEMBLY OF VACUUM ATTACHMENT

1) Installing Vacuum pipe (nozzle)

- (1) Loosen the screw ④ and open the protector ⑤.



WARNING!

When using the blower for blowing operation, always close the protector ⑤ and tighten the screw ④ before operation. Otherwise the bare impeller may catch your body or clothing and cause serious injury.

Always use the vacuum pipe A and B together. Otherwise contact with the impeller may cause serious injury when the operator attempts to remove jammed debris in the pipe.

- (2) Align “▲” mark on the vacuum pipe A and B. Insert the vacuum pipe A into the vacuum pipe B until three latches snap in.
- (3) Align the ◀ MARK indicated on the vacuum pipe A with the “●” indicated on the blower. Then insert the vacuum pipe into the blower.
- (4) Turn the vacuum pipe until the ▶ MARK is aligned with the “▼” indicated on the blower to lock the vacuum pipe.

Note: The engine will not start unless the vacuum pipe is mounted completely.

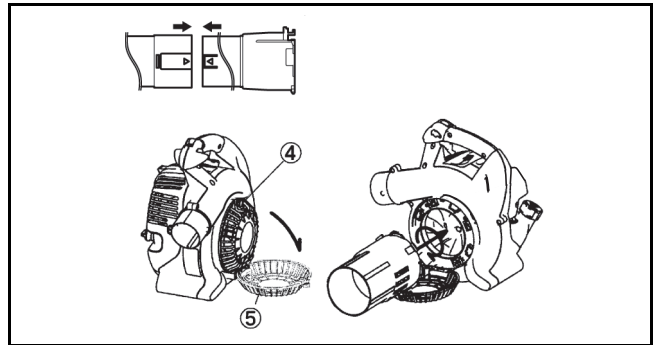

2) Installing Elbow and Dust Bag

- (1) Open the fastener of the dust bag.
- (2) Insert the elbow's railed side into the dust bag, take it out through the bag's entry.
- (3) Fasten the elbow with hook-and-loop fastener around the place indicated in the figure.

CAUTION

Install the dust bag away from railed side of the elbow. If the dust bag is placed near the engine, the exhaust gas may scorch the dust bag.

- (4) Install the elbow on the blower.



WARNING!

Do not attempt to pick up large wood chips, metals, glass, stones, liquids, lighted cigarettes, fire works or the like.

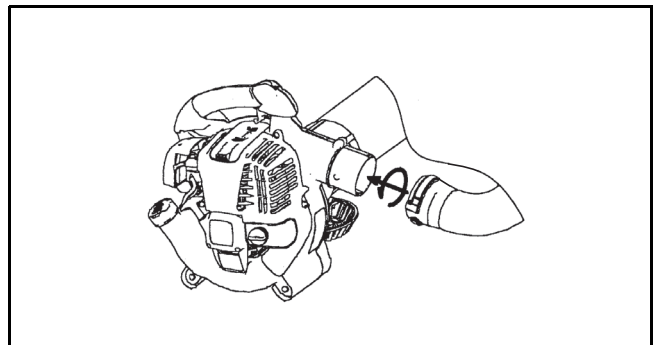
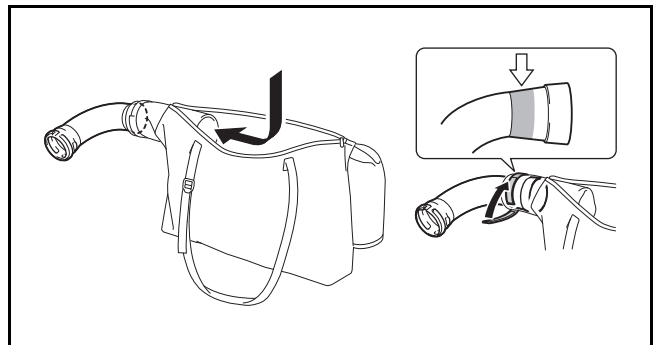

BEFORE START OF OPERATION

1. Inspection and Refill of Engine Oil

(1) Perform the following procedure when the engine is cool.

Assure engine is on a flat horizontal surface as shown in Figure 1.

- **Inspection:** Remove the oil cap. Wipe clean the oil level indicator. Reinstall the oil cap (Figure 2) and remove. Confirm if the oil is between the lower or upper limit of the oil indicator.
- **Refill:** After inspection if the oil is below the lower limit add oil through the same opening that the oil cap was removed. See Figure 4 on how to orient the engine to refill the oil.

(2) You may need to refill oil approximately every 10 hours of use (every 10 refuellings).

(3) If the oil changes in color or mixes with dirt, replace the oil. (For the interval and method of replacement, refer to P. 15)

Recommended oil: SAE 10W-30 oil of API Classification, Class SF or higher (4-stroke engine for automobile)

Oil volume: Approx. 0.08 L

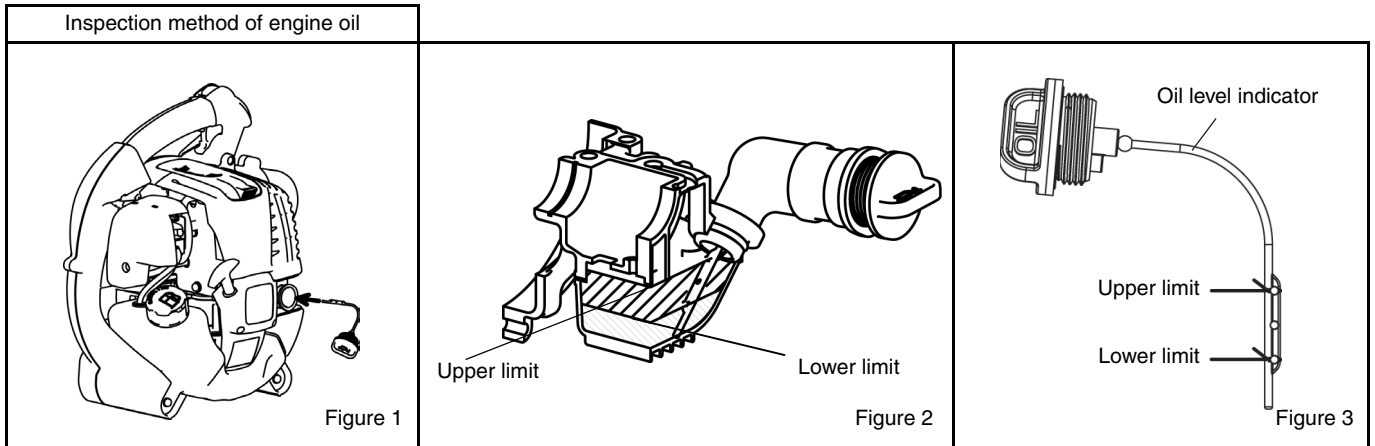

NOTE

- If the engine is not positioned as in Figure 1 on a horizontal surface, an inaccurate indication of oil level may occur.
- If the oil is filled above the limit, oil may be contaminated or may catch fire with white smoke.

Replacement of Oil “Oil Gauge”

- Remove dust or dirt near the oil refill port, and detach the oil gauge.
- Keep the detached oil gauge free of sand or dust. Otherwise, any sand or dust adhering to the oil gauge may cause irregular oil circulation or wear on the engine parts, which will result in troubles.
- As an example to keep the oil gauge clean, it is recommended to insert the oil gauge on its knob side into the engine cover.

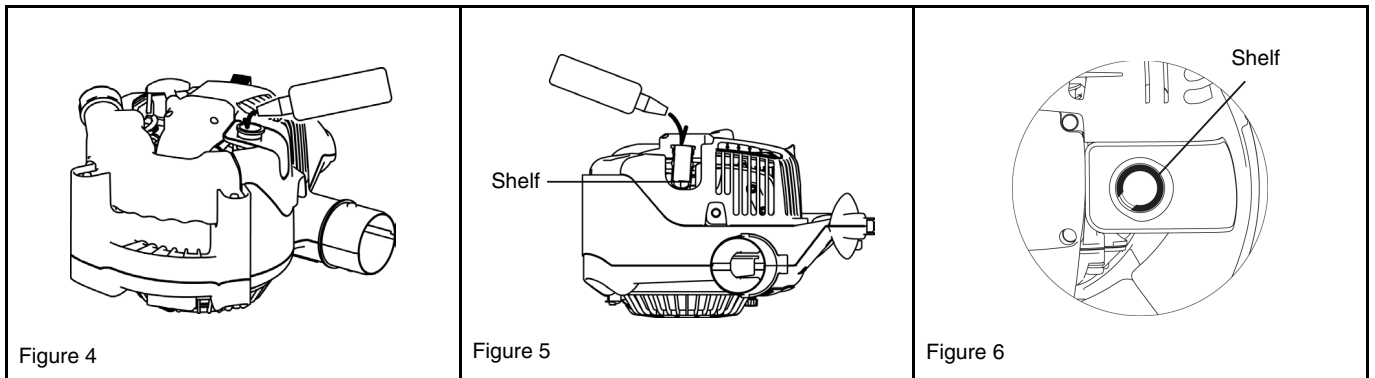

After refilling oil

- Wipe with a rag any spilled oil.

2. Fuel supply



- When refuelling the unit, be sure to observe the following instructions to prevent ignition or fire:
 - Fuel supply must be made in a place free of fire. Never bring the fire (smoking, etc.) near the place of fuel supply.
 - Stop the engine and allow the engine to cool down before refuelling.
 - Open the fuel tank cap slowly. The fuel may be spilled out under internal pressure.
 - Take care not to spill the fuel. Any spilled fuel must be wiped clean.
 - Carry out fuel supply in a well-ventilated place.
- Handle the fuel with care.
 - Fuel sticking to the skin or entering an eye may cause allergies or irritation. When any physical abnormality is detected, consult the medical specialist immediately.
- DO NOT put oil in the fuel tank.

STORAGE PERIOD OF FUEL

Fuel should be used within a period of 4 weeks, even if it is kept in a special container in a well-ventilated shaded area. If a special container is not used or if the container is not covered, fuel may deteriorate in one day.

Storage of machine and refill tank

- Keep the machine and tank at a cool place free from direct sunshine.
 - Never keep the fuel in a car.
-
-

FUEL

The engine is a four-stroke engine. Be sure to use an automobile gasoline (regular gasoline or premium gasoline).

Points for Fuel

- Never use a gasoline mixture which contains engine oil. Otherwise, it will cause excessive carbon accumulation or mechanical troubles.
 - Use of deteriorated oil will cause irregular startup.
-
-

When refuelling, be sure to stop the engine and confirm that the engine cools down.

REFUELLING METHOD

- Loosen the tank cap a little to release the tank pressure.
- Detach the tank cap, and refuel, discharging air by tilting the fuel tank so that the refuel port will be oriented upward. (DO NOT fill fuel up to the top of the tank.)
- After refuelling, securely tighten the tank cap.
- If there is any flaw or damage on the tank cap, replace it.
- The tank cap wears out in course of time. Replace it every two to three years.
- DO NOT put fuel in the oil fill port.

OPERATION



1. Starting

WARNING

- Never attempt engine start in a place where the fuel has been supplied.
 - If may cause ignition or fire. When starting the engine, keep a distance of at least 3 m.
- Exhaust gas from the engine is toxic. Do not operate the engine in a poorly-ventilated place, such as in a tunnel, building, etc.
 - Operating the engine in the poorly-ventilated place may cause poisoning by exhaust gas.
- In case of detection of any abnormality in sound, odor, vibration after start, stop the engine immediately and carry out inspection.
 - If the engine is operated without attending such abnormality, an accident may occur.
- Confirm that the engine stops when the stop switch is set to "O" position.

1) When the engine is cold or after refuelling

- (1) Set this machine on a flat space.
- (2) Set the stop switch to "I" position (Figure 1).
- (3) Continue to push the primer pump until fuel comes into the primer pump (Figure 2).
 - In general, fuel enters into the carburetor by 7 to 10 pushes.
 - If the primer pump is pushed excessively, an excess of gasoline returns to the fuel tank.
- (4) Lift the choke lever to the closed position (Figure 3).
- (5) Hold the main handle with left hand to prevent the engine from moving.
- (6) Pull out slowly the starter handle till a certain resistance is felt. Return the starter handle backward once from this position, then pull it out with force (Figure 4).
- Never pull the rope to the full extension.
- Once the start knob is pulled, never release your hand immediately. Hold the start knob until it returns to its original point.
- (7) When the engine starts, open the choke lever (Figure 5).
 - Open the choke lever progressively while checking the engine operation. Be sure to open the choke lever to the full in the end.
 - In cold or when the engine is cooled down, never open the choke lever suddenly. Otherwise, the engine may stop.
- (8) Continue warm-up operation for 2 to 3 minutes.
- (9) Warm-up is complete when there is quick engine acceleration from low rpm to full throttle.

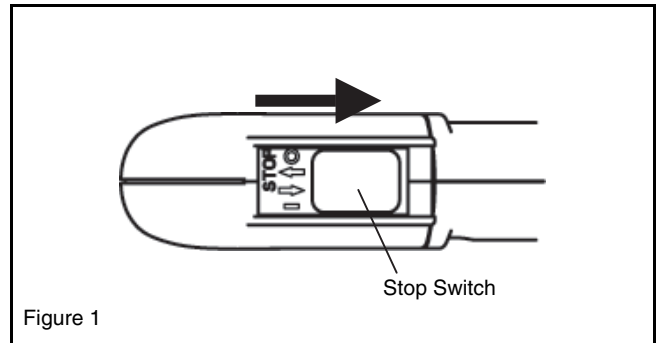

Figure 1

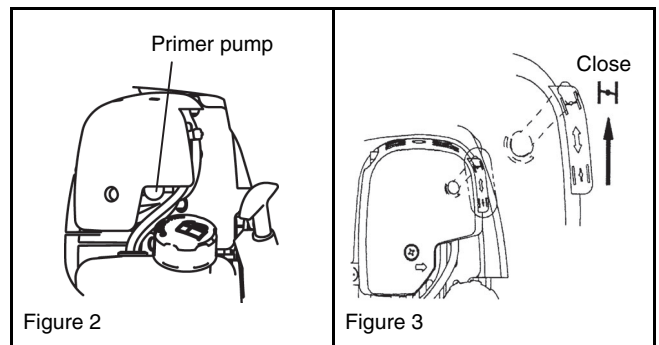

Figure 2

Figure 3

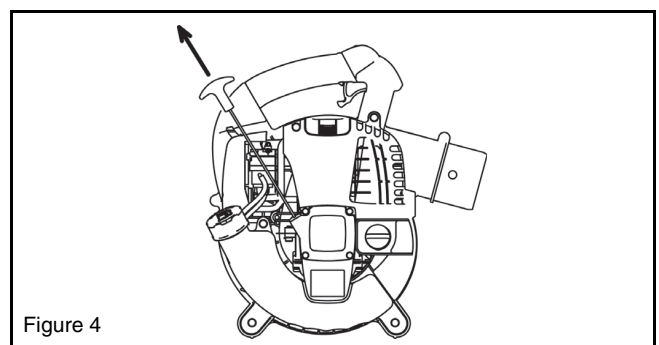

Figure 4

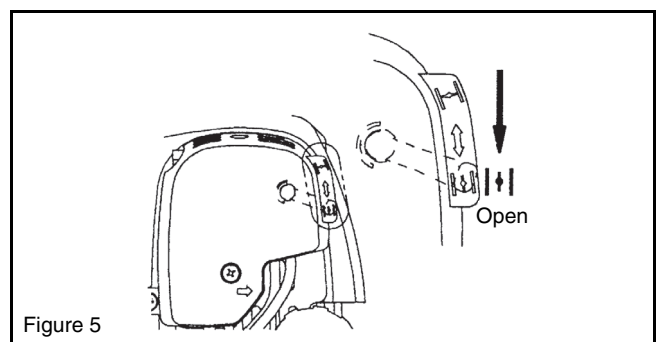

Figure 5

NOTE

- The engine may be damaged if the choke lever is moved further beyond the “CLOSE” position.
- If the engine fires and stops, return this lever to the “OPEN” position and pull the starter handle several times to start the engine again.
- If the operator keeps pulling the starter handle several times with the choke lever left in the “CLOSE” position, the engine may be difficult to start because of flooding of the fuel.
- In case of flooding of the fuel, remove the spark plug and pull the handle several times rapidly to discharge any excess fuel. Dry the spark plug electrode.
- When the throttle valve does not return to a position in contact with the idling adjusting screw even if the throttle lever is set to the low speed, correct the control cable catching state to ensure proper return of the valve.

2) When the engine is warm

- (1) Place the engine on a flat ground.
- (2) Press the primary pump several times.
- (3) Confirm that the choke lever is open.
- (4) Hold the main handle with left hand to prevent the engine from moving.
- (5) Pull out slowly the starter handle till a certain resistance is felt. Return the starter handle backward once from this position, then pull it out with force.
- (6) When the engine is difficult to start, open the throttle valve by about 1/3.

2. Stopping

1) When the cruise control lever is OFF

Release the trigger lever to reduce the engine speed, and set the stop switch to the “O” position.

2) When the cruise control lever is ON

Set the cruise control lever to the OFF position, reduce the engine speed, and set the stop switch to the “O” position.

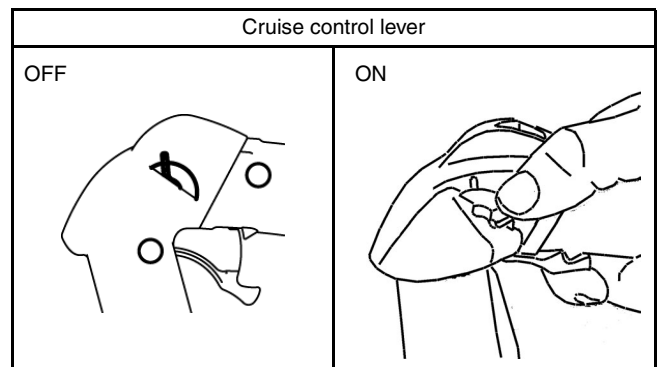

ADJUSTMENT OF IDLING



DANGER

The carburetor is factory adjusted. Please do not adjust other than idling adjusting. When adjustment becomes necessary, please consult your dealership or an authorized service agent.

Checkup of low-speed rotation

Set the low-speed rotation to 3500 rpm (min^{-1}).

- If it is necessary to change the rotation speed, regulate the adjusting screw, with Phillips screwdriver.
- Turn the adjusting screw to the right, and the engine speed will increase. Turn the adjusting screw to the left, and the engine speed will drop.

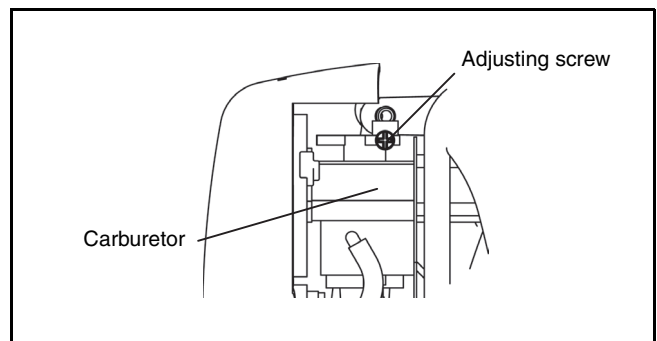

Prevention from carburetor icing

NOTICE

When environmental temperature is higher than 10°C, always close the shutter (normal setting).
Otherwise the engine may be damaged by overheating.

When the environmental temperature is low and humidity is high, water vapor may freeze inside the carburetor and the engine drives unsteadily (carburetor icing).

Change the setting of the shutter as follows as necessary.

• Warmer environment than 10°C

Hold the tab on the shutter and slide it to the left (closed position).

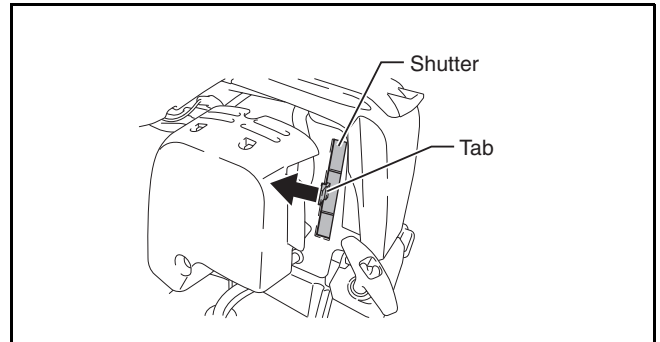

• 10°C or colder environment

Hold the tab on the shutter and slide it to the right (open position).

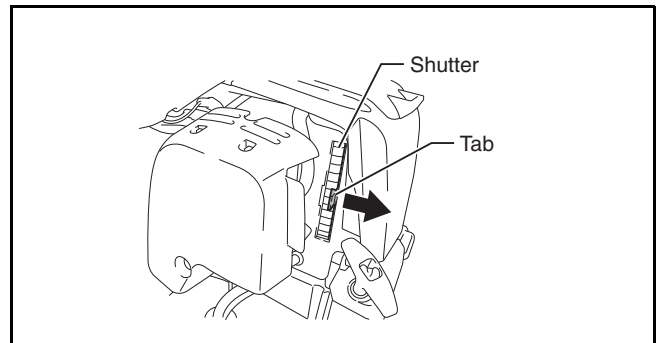

OPERATION METHOD

1. Blower operation

- Hold the machine firmly during operation.
- Direct the nozzle end toward the object to be dusted and pull the trigger lever.
- The trigger lever can be fixed in an arbitrary position with the cruise control lever.
- Maintain the trigger lever at a position where the engine speed appropriate for the operation is obtained and set the cruise control lever to the "ON" position.
- To adjust the engine speed, set the cruise control lever to the "OFF" position once, adjust the engine speed with the trigger lever again, then set and fix the cruise control lever to the "ON" position.
- Operation of the trigger lever with the cruise control lever in the "ON" position may cause failure.
- The lower portion of the fuel tank acts as an assist handle, which enables operation with both hands. In this case, be sure to hold the assist handle with a right hand.

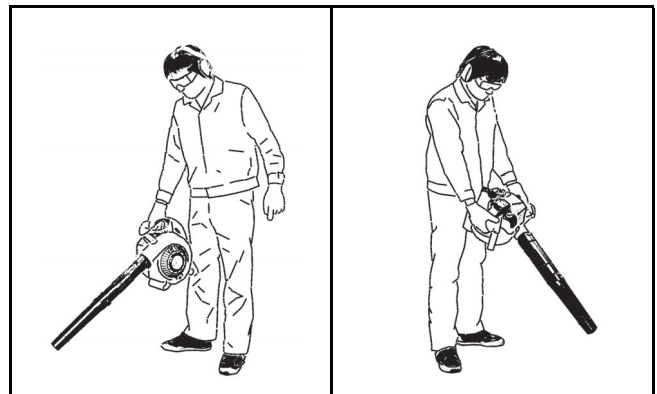

2. Dust Collection Operation

WARNING

- Do not allow kerosene, gasoline, or lighted cigarette to be sucked into the machine.
 - Otherwise, fire may occur.
- Do not allow foreign materials, such as large wood chips, metals, glass, pebbles, etc., to be sucked into the machine.
 - Otherwise, failure may occur.
- Overfilling of the dust bag may cause its overflow toward the engine side. Empty the bag before it becomes completely full.
 - Otherwise, fire may occur.

- Carry the dust bag belt on the shoulder and adjust the belt length to ensure easy operation.
- Confirm that the dust bag is not twisted and pull the trigger lever to start dust collection.
- When the dust bag is full, remove the dust bag from the machine and open the fastener to empty the bag.



NOTE

If this machine is operated with the protector oriented upwards or the main handle downwards, white smoke may appear, oil may be contaminated or oil may leak.

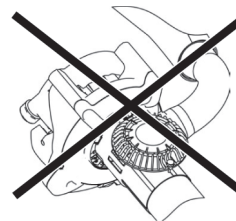
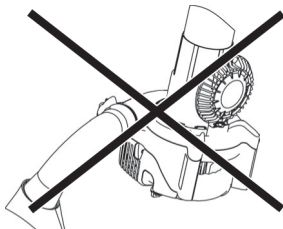
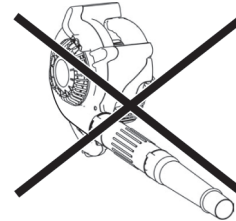
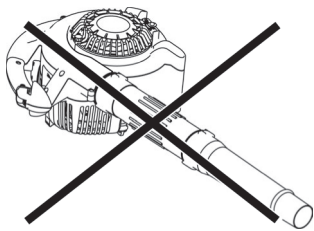



DANGER

- Before inspection and maintenance, stop the engine and allow it to cool. Remove the spark plug and plug cap.
 - If inspection or maintenance is attempted immediately after engine stop or with the plug cap left attached, the operator may suffer burn or an accident due to careless startup.
- After inspection and maintenance, be sure to confirm that all parts are assembled. Then, proceed to operation.

1. Replacement of engine oil

Deteriorated engine oil will shorten the life of the sliding and rotating parts to a great extent. Be sure to check the period and quantity of replacement.

DANGER

- In general, the engine main unit and engine oil still remain hot just after the engine is stopped. In replacement of oil, confirm that the engine main unit and engine oil are sufficiently cooled down. Otherwise, there may remain a risk of scald. Allow sufficient time after stopping engine for the engine oil to return to the oil tank to ensure accurate reading of the oil level indicator.
- If the oil filled above the limit, it may be contaminated or may catch fire with white smoke.

Interval of replacement: After first 20 operating hours, followed by every 50 operating hours

Recommended oil: SAE10W-30 oil of API Classification SF Class or higher (4-stroke engine oil for automobile)

In replacement, perform the following procedure.

- (1) Confirm that the tank cap is tightened securely.
- (2) Detach the oil cap.
 - Keep the oil gauge free from dust or dirt.
- (3) Tilt the machine in order as shown in Figure 1.
 - Drain the oil in a container.
- (4) Orient the machine as shown in Figure 2 and refill oil to the shelf inside the oil pipe.
- (5) After refill, securely tighten the oil gauge. Insufficient tightening of the oil gauge will lead to oil leakage.

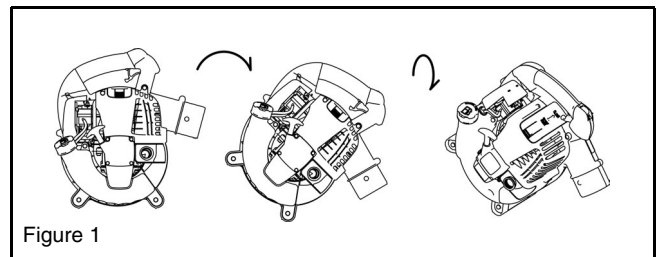

Figure 1

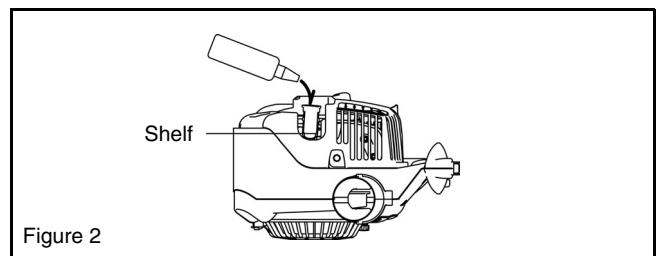

Figure 2

Points in replacement of engine oil

- Never discard replaced engine oil in garbage, earth or sewage ditch. Disposal of oil is regulated by law. In disposal, always follow the relevant laws and regulations. For any points remaining unknown, contact Authorized Service Agent.
- Oil will deteriorate even when it is kept unused. Perform inspection and replacement at regular intervals (replace with new oil every 6 months).

2. Cleaning of air cleaner



WARNING: INFLAMMABLES STRICTLY PROHIBITED

Interval of Cleaning and Inspection: Daily (every 10 operating hours)

- (1) Remove the air cleaner cover-fixing bolts.
- (2) Pull the cover lower side and detach the air cleaner cover.
- (3) Turn the choke lever to the full close side, and keep the carburetor off from dust or dirt.
- (4) If oil adheres to the element (sponge), squeeze it firmly.
- (5) For heavy contamination:
 - Remove the element (sponge), immerse it in warm water or in water-diluted mild detergent, and dry it completely.
 - Clean the element (felt) with gasoline, and dry it completely.
- (6) Before attaching the element, be sure to dry it completely. Insufficient drying of the element may lead to difficult startup.
- (7) Wipe out with waste cloth, oil adhering around the air cleaner cover and plate breather.
- (8) Immediately after cleaning is finished, attach the air cleaner cover and tighten it with fixing bolts. (In remounting, first place the upper claw, and then the lower claw.)

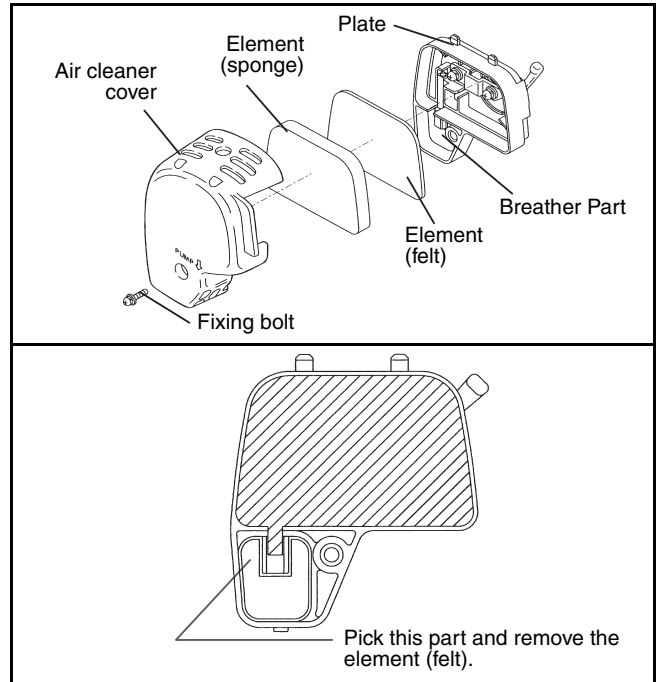

! DANGER

- Clean the element several times a day, if excessive dust adheres to it.
- If operation continues with the element remaining not cleared of oil, oil in the air cleaner may fall outside, resulting in oil contamination.

3. Checking the spark plug

- (1) Opening/closing the plug cover

When opening the cover, apply fingers to the main handle and plug cover projection (Figure 1). Push up the projection and slide the cover in the "OPEN" direction (Figure 2).

When closing the cover, slide the cover in the "CLOSE" direction till the click under the plug cover projection rides over the engine cover. Finally, push in the projection.
- (2) Removing the spark plug

Use an attached box wrench to remove or install the spark plug (Figure 3).
- (3) Checking the spark plug

The clearance between two electrodes of spark plug is 0.7 to 0.8 mm (Figure 4). Adjust to the correct clearance when it is too wide or too narrow.

Clean thoroughly or replace the spark plug if it has accumulated carbon or contaminated.
- (4) Replacing the spark plug

For replacement, use NGK-CMR6A.

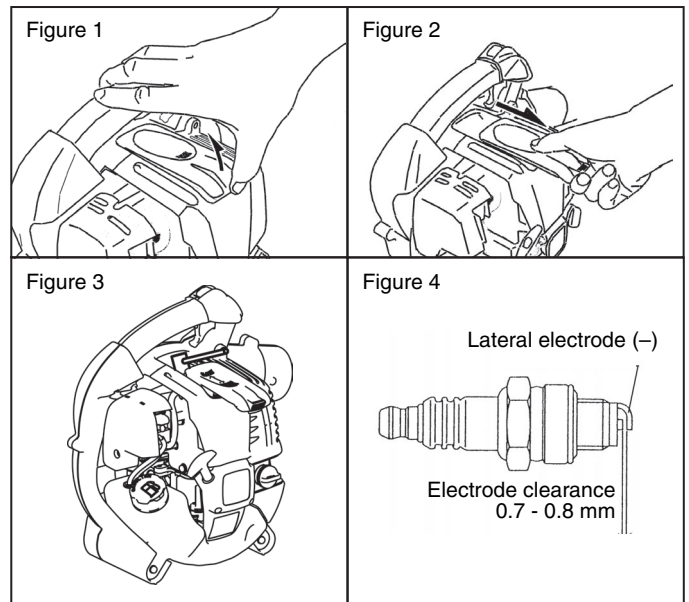

4. Cleaning the fuel filter

- Clogged fuel filter may cause difficulty of startup or failure of engine speed increase.
- Check the fuel filter regularly as follows:
 - (1) Remove the fuel tank cap, drain the fuel to empty the tank. Check the tank inside for any foreign materials. If any, wipe clean such materials.
 - (2) Pull out the fuel filter using a wire through the fuel filling port.
 - (3) If the fuel filter surface is contaminated, clean it with gasoline. The gasoline used for the cleaning must be disposed of according to the method specified by each local authority. Excessively contaminated filter must be replaced.
 - (4) Reset the fuel filter in the fuel tank and tighten firmly the fuel tank cap. For replacement, contact your dealership or an authorized service agent.

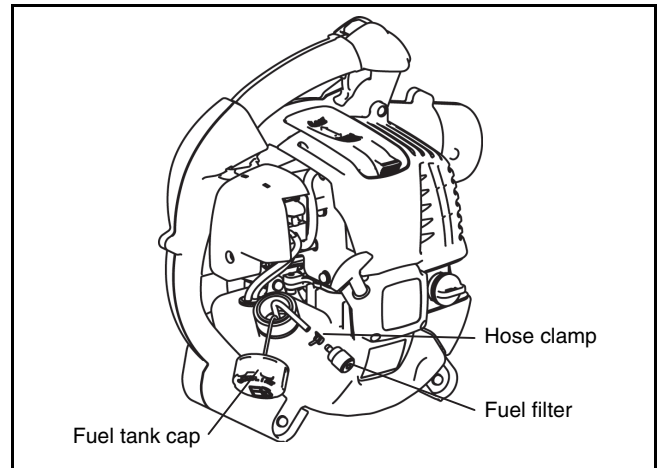

5. Inspection of bolts, nuts and screws

- Retighten loose bolts, nuts, etc.
- Check for fuel and oil leakage.
- Replace damaged parts with new ones for safety operation.

6. Cleaning of parts

- Keep engine clean by wiping down with a cloth rag.
- Keep the cylinder fins free of dust or dirt. Dust or dirt adhering to the fins will cause seizure.

7. Replacement of gaskets and packings

Replace gaskets and packings if the engine is disassembled.

Any maintenance or adjustment work that is not included and described in this manual is only to be performed by Authorized Service Agents.

STORAGE

⚠ WARNING

- When draining the fuel, be sure to stop the engine and confirm that the engine cools down.
 - Failure to do so may cause burns or fire.

⚠ DANGER

- When you store the machine for a long time, drain all fuel from the fuel tank and carburetor, and keep it at a dry and clean place.

Drain fuel from the fuel tank and carburetor according to the following procedure:

- (1) Remove the fuel tank cap, and drain fuel completely. If there is any foreign matter remaining in the fuel tank, remove it completely.
- (2) Pull out the fuel filter from the refill port using a wire.
- (3) Push the primer pump until fuel is drained from there, and drain fuel coming into the fuel tank.
- (4) Reset the filter to the fuel tank, and securely tighten the fuel tank cap.
- (5) Then, continue to operate the engine until it stops.
- (6) Remove the spark plug, and drip several drops of engine oil through the spark plug hole.
- (7) Gently pull the starter handle so that engine oil will spread over the engine, and attach the spark plug.
- (8) Keep the machine with its handle upside.
- (9) Keep the drained fuel in a special container in a well-ventilated shade.

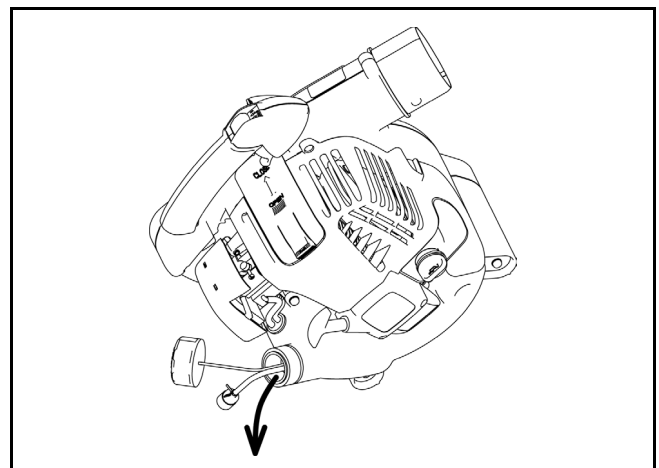

Fault location

Fault	System	Observation	Cause
Engine not starting or with difficulty	Ignition system	Ignition spark O.K.	Fault in fuel supply or compression system, mechanical defect
		No ignition spark	STOP-switch operated, wiring fault or short circuit, spark plug or connector defective, ignition module faulty
	Fuel supply	Fuel tank filled	Incorrect choke position, carburetor defective, fuel supply line bent or blocked, fuel dirty.
	Compression	No compression when pulled over	Cylinder bottom gasket defective, crankshaft seals damaged, cylinder or piston rings defective or improper sealing of spark plug
Warm start problems	Mechanical fault	Starter not engaging	Broken starter spring, broken parts inside of the engine
		Tank filled ignition spark existing	Carburetor contaminated, have it cleaned
Engine starts but dies	Fuel supply	Tank filled	Incorrect idling adjustment, carburetor contaminated Fuel tank vent defective, fuel supply line interrupted, cable or STOP-switch faulty
Insufficient performance	Several systems may simultaneously be affected	Engine idling poor	Air filter contaminated, carburetor contaminated, muffler clogged, exhaust duct in the cylinder clogged

Item	Operating time		Operating time					Shutdown/ rest	Corresponding Page
			Before operation	After lubrication	Daily (10h)	30h	50h		
Engine oil	Inspect/clean	○							9
	Replace					○*1			15
Tightening parts (bolt, nut)	Inspect	○							17
Fuel tank	Clean/inspect	○							–
	Drain fuel						○*3		17
Throttle lever	Check function		○						–
Stop switch	Check function		○						12
Low-speed rotation	Inspect/adjust			○					12
Air cleaner	Clean			○					16
Ignition plug	Inspect			○					16
Cooling air duct	Clean/inspect			○					17
Fuel pipe	Inspect			○					17
	Replace						◎*2		–
Fuel filter	Clean/replace					○			17
Clearance between air intake valve and air discharge valve	Adjust						◎*2		–
Oil tube	Inspect						◎*2		–
Engine overhaul							◎*2		–
Carburetor	Drain fuel						○*3		17

*1 Perform initial replacement after 20h operation.

*2 For the 200 operating hour inspection, request Authorized Service Agent or a machine shop.

*3 After emptying the fuel tank, continue to run the engine and drain fuel in the carburetor.

TROUBLESHOOTING

Before making a request for repairs, check a trouble for yourself. If any abnormality is found, control your machine according to the description of this manual. Never tamper or dismount any part contrary to the description. For repairs, contact Authorized Service Agent or local dealership.

State of abnormality	Probable cause (malfunction)	Remedy
Engine does not start	Failure to operate primer pump	Push 7 to 10 times.
	Low pulling speed of starter rope	Pull strongly.
	Lack of fuel	Feed fuel.
	Clogged fuel filter	Clean
	Broken fuel tube	Straighten fuel tube
	Deteriorated fuel	Deteriorated fuel makes starting more difficult. Replace with new one. (Recommended replacement: 1 month)
	Excessive suction of fuel	Set throttle lever from medium speed to high speed, and pull starter handle until engine starts. If engine will not start still, remove spark plug, make electrode dry, and reassemble them as they originally are. Then, start as specified.
	Detached plug cap	Attach securely
	Contaminated spark plug	Clean
	Abnormal clearance of spark plug	Adjust clearance
	Other abnormality of spark plug	Replace
	Abnormal carburetor	Make request for inspection and maintenance.
	Starter rope cannot be pulled	Make request for inspection and maintenance.
	Abnormal drive system	Make request for inspection and maintenance.
Engine stops soon Engine speed does not increase	Insufficient warm-up	Perform warm-up operation
	Choke lever is set to "CLOSE" although engine is warmed up	Set to "OPEN"
	Clogged fuel filter	Clean
	Contaminated or clogged air cleaner	Clean
	Abnormal carburetor	Make request for inspection and maintenance.
	Abnormal drive system	Make request for inspection and maintenance.
	Detached throttle wire	Attach securely
	Abnormal drive system	Make request for inspection and maintenance.
Engine does not stop. ↓ Run engine at idling, and set choke lever to CLOSE.	Detached connector	Attach securely
	Abnormal electric system	Make request for inspection and maintenance.

When the engine does not start after warm-up operation:

If there is no abnormality found for the check items, open the throttle by about 1/3 and start the engine.

Makita Corporation
3-11-8, Sumiyoshi-cho,
Anjo, Aichi 446-8502 Japan
www.makita.com

884857G889

IDE