

Model No.BCX2510 STRING TRIMMER

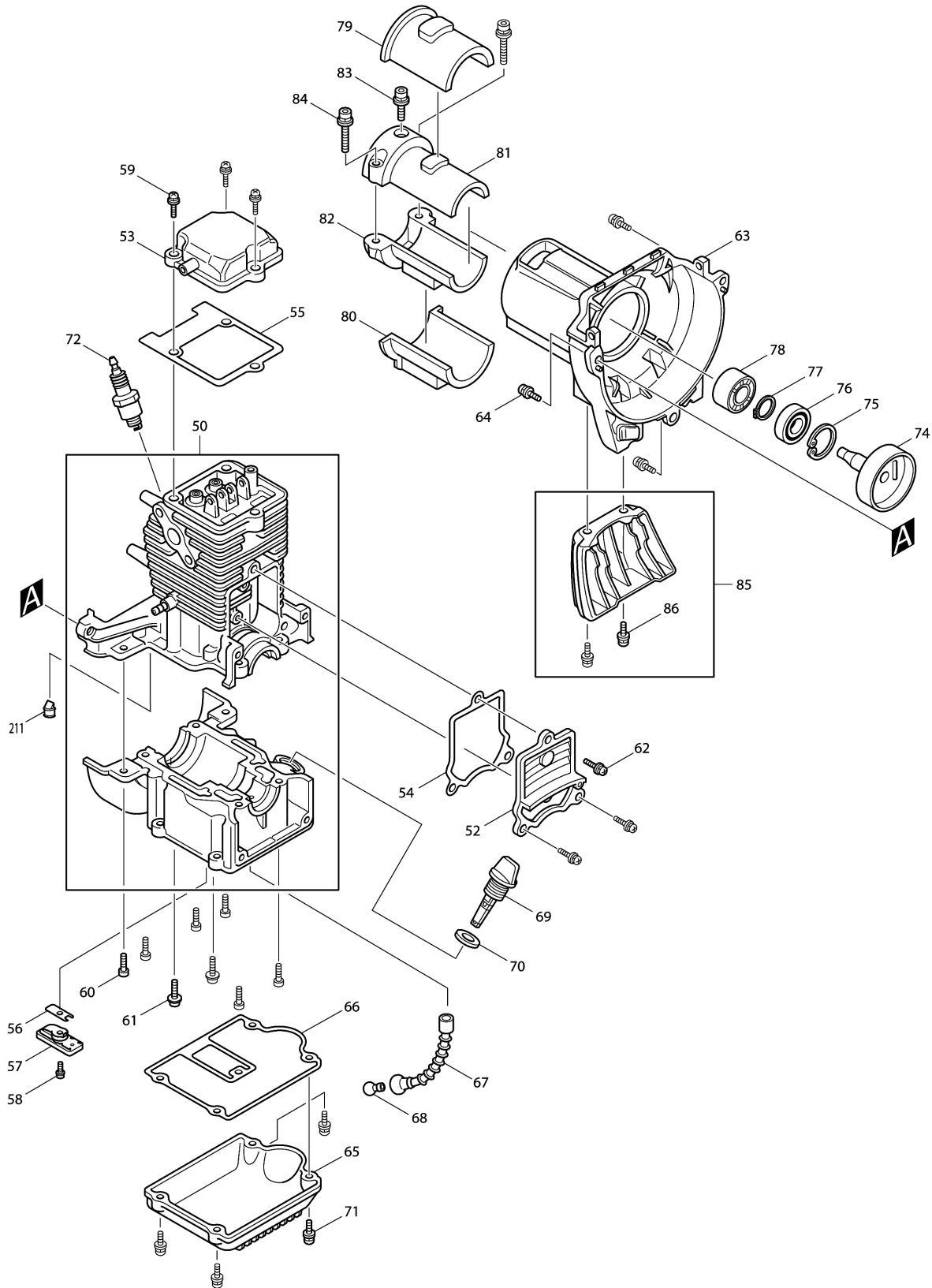

Model No.BCX2510 STRING TRIMMER

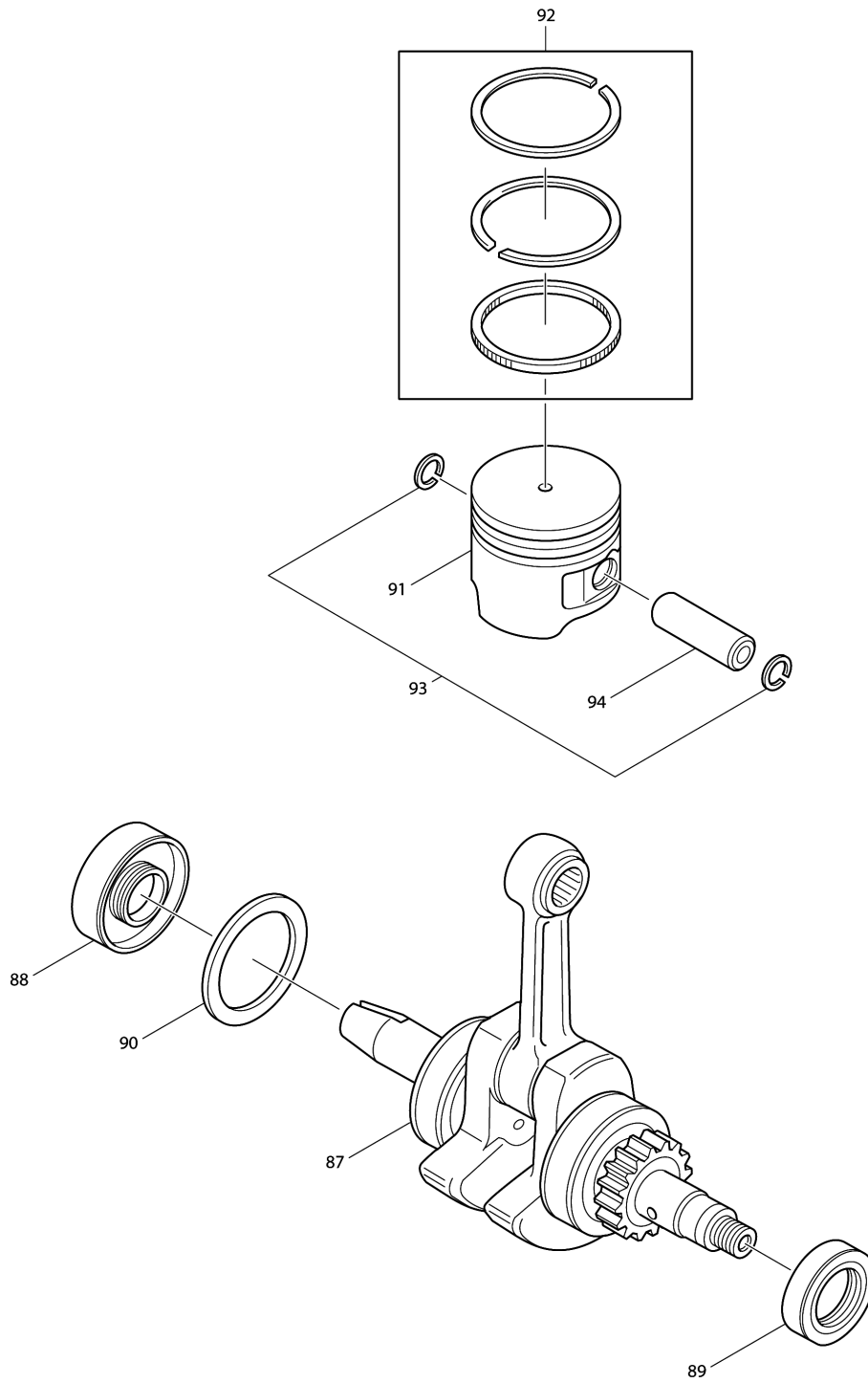

Model No.BCX2510 STRING TRIMMER

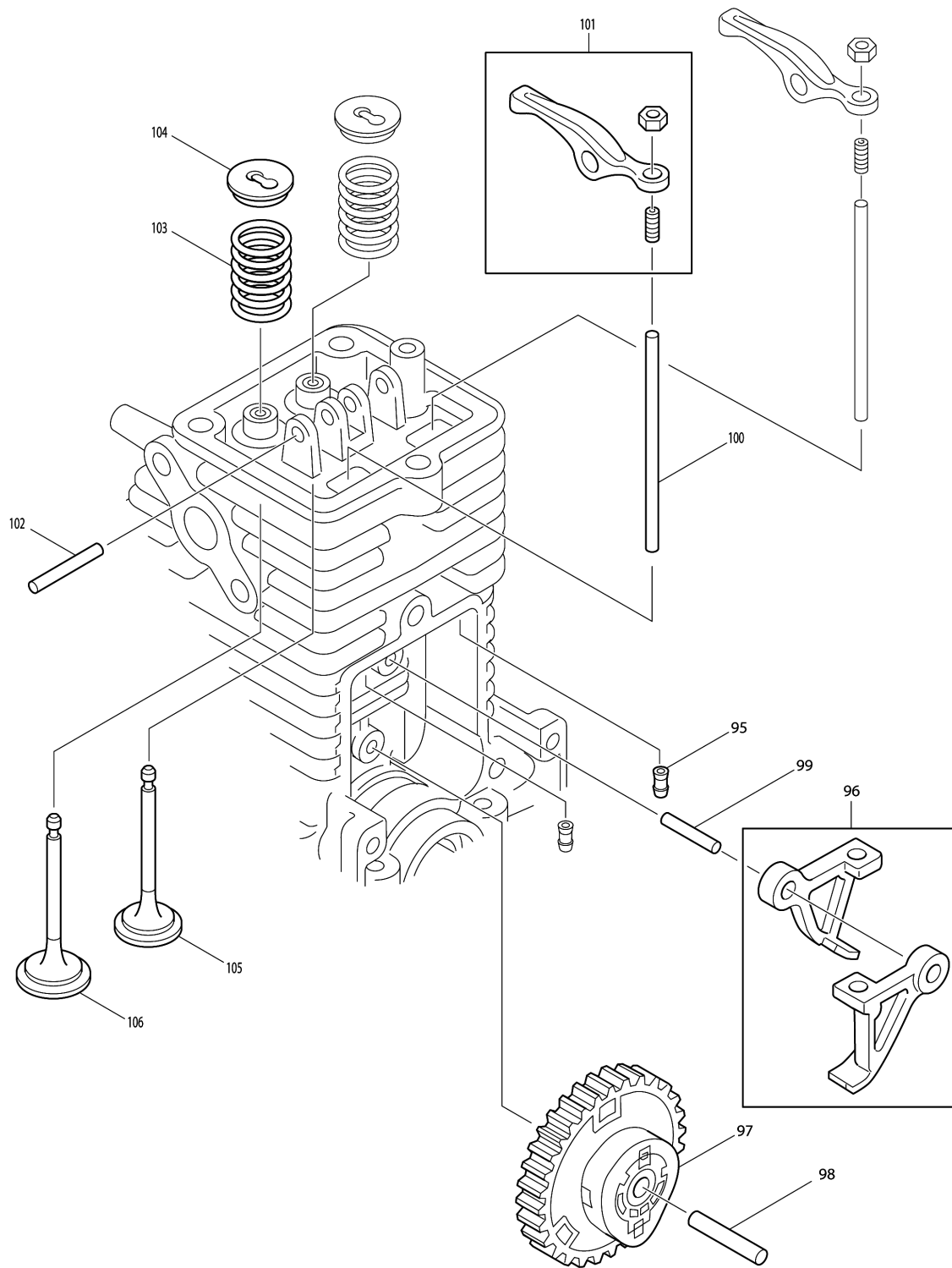

Model No.BCX2510 STRING TRIMMER

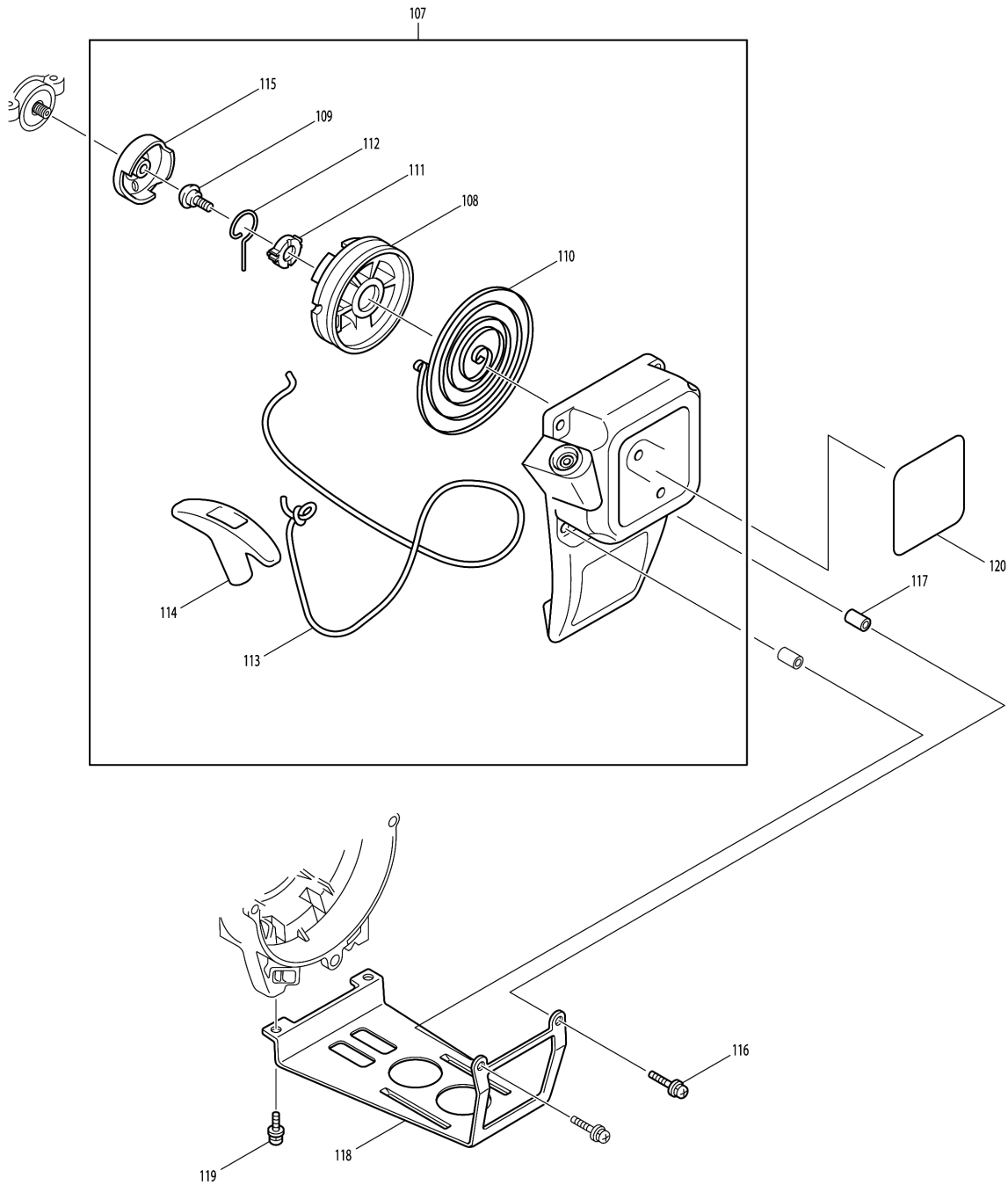

Model No.BCX2510 STRING TRIMMER

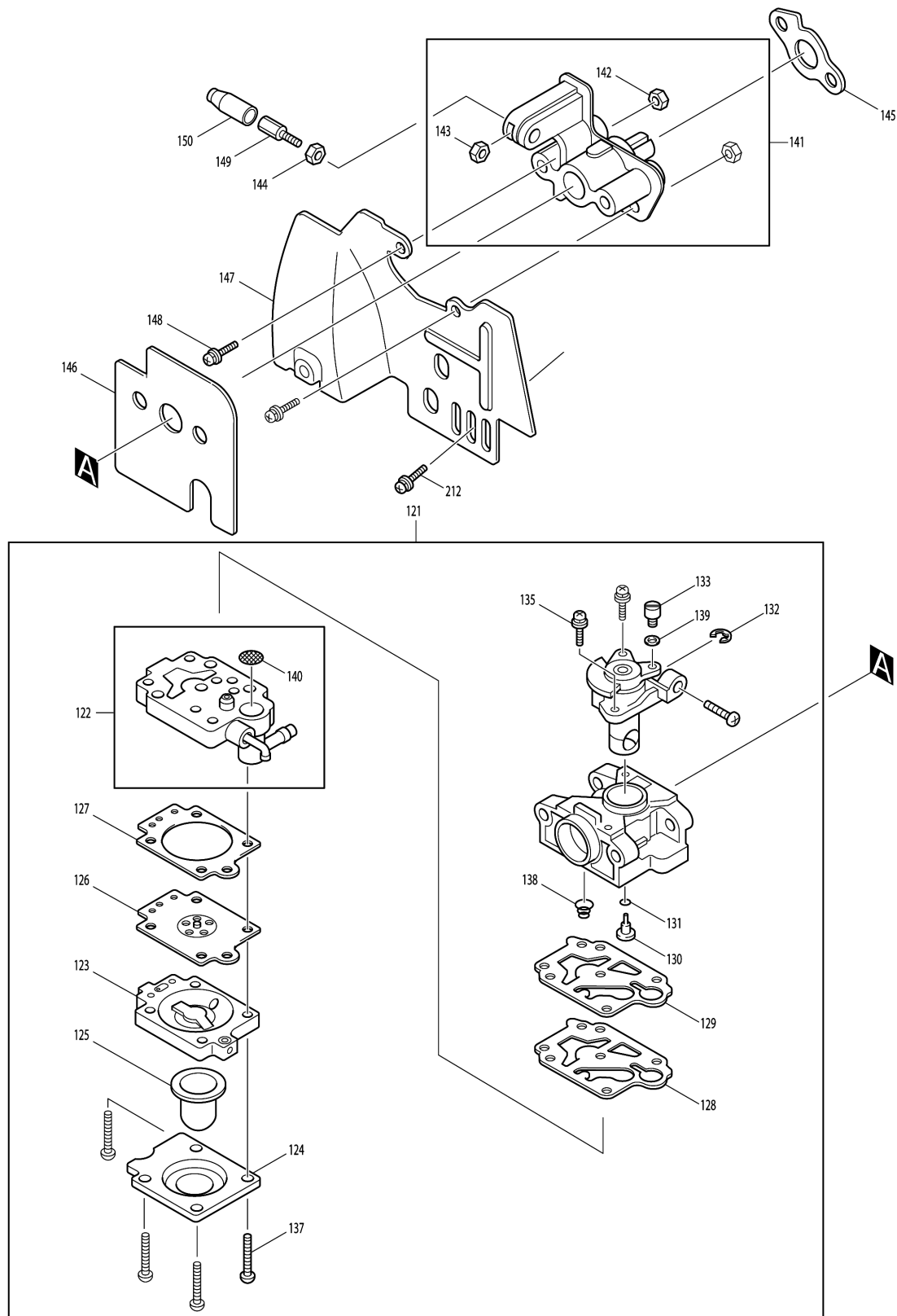

Model No.BCX2510 STRING TRIMMER

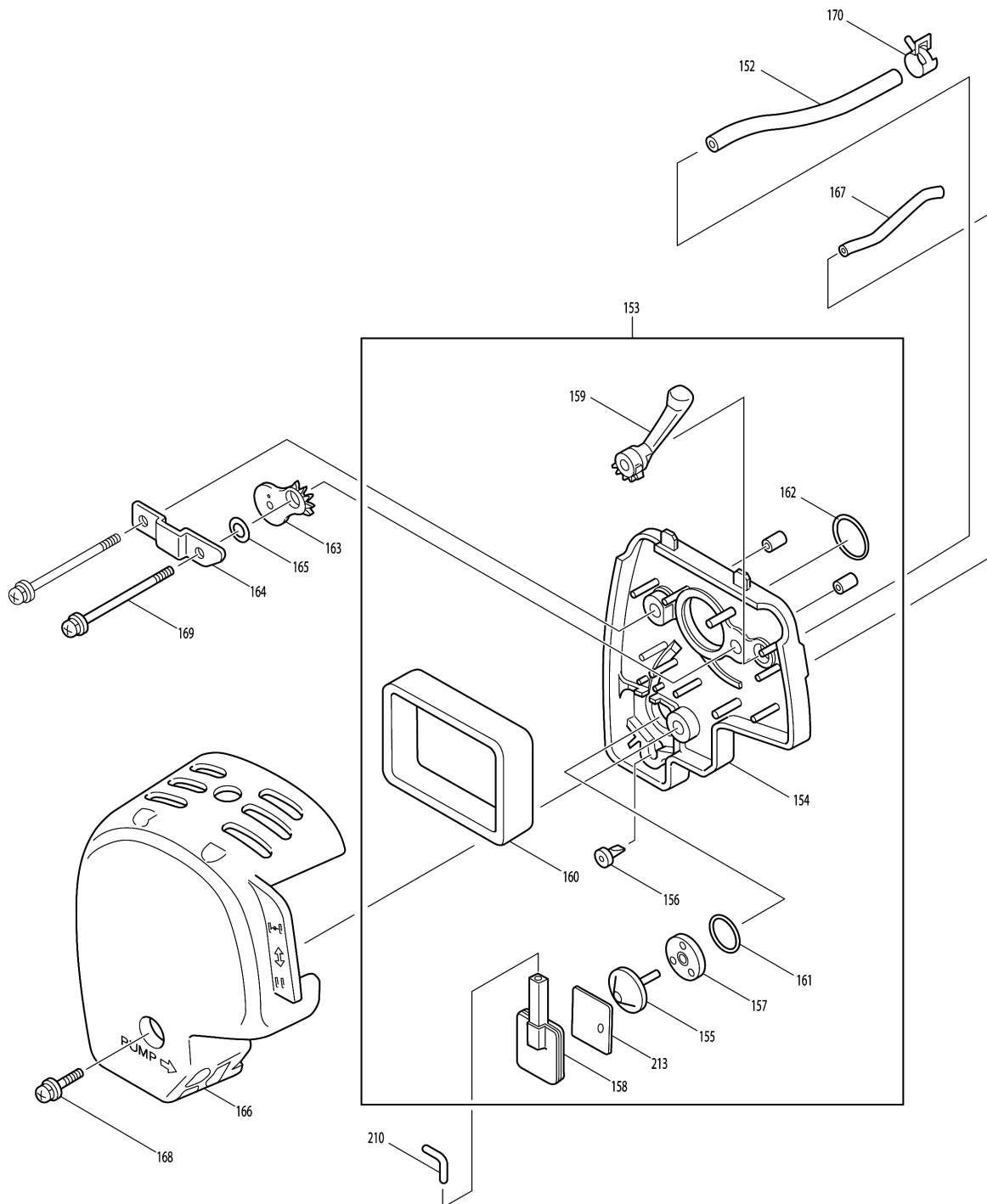

Model No.BCX2510 STRING TRIMMER

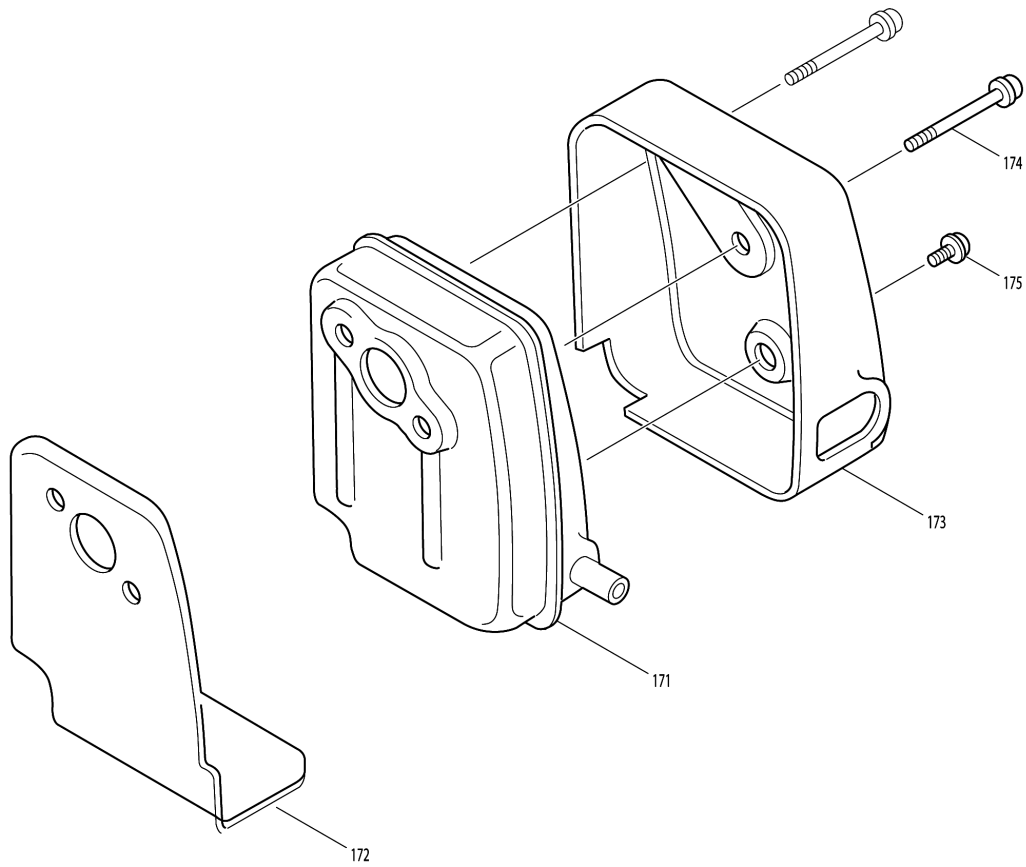

Model No.BCX2510 STRING TRIMMER

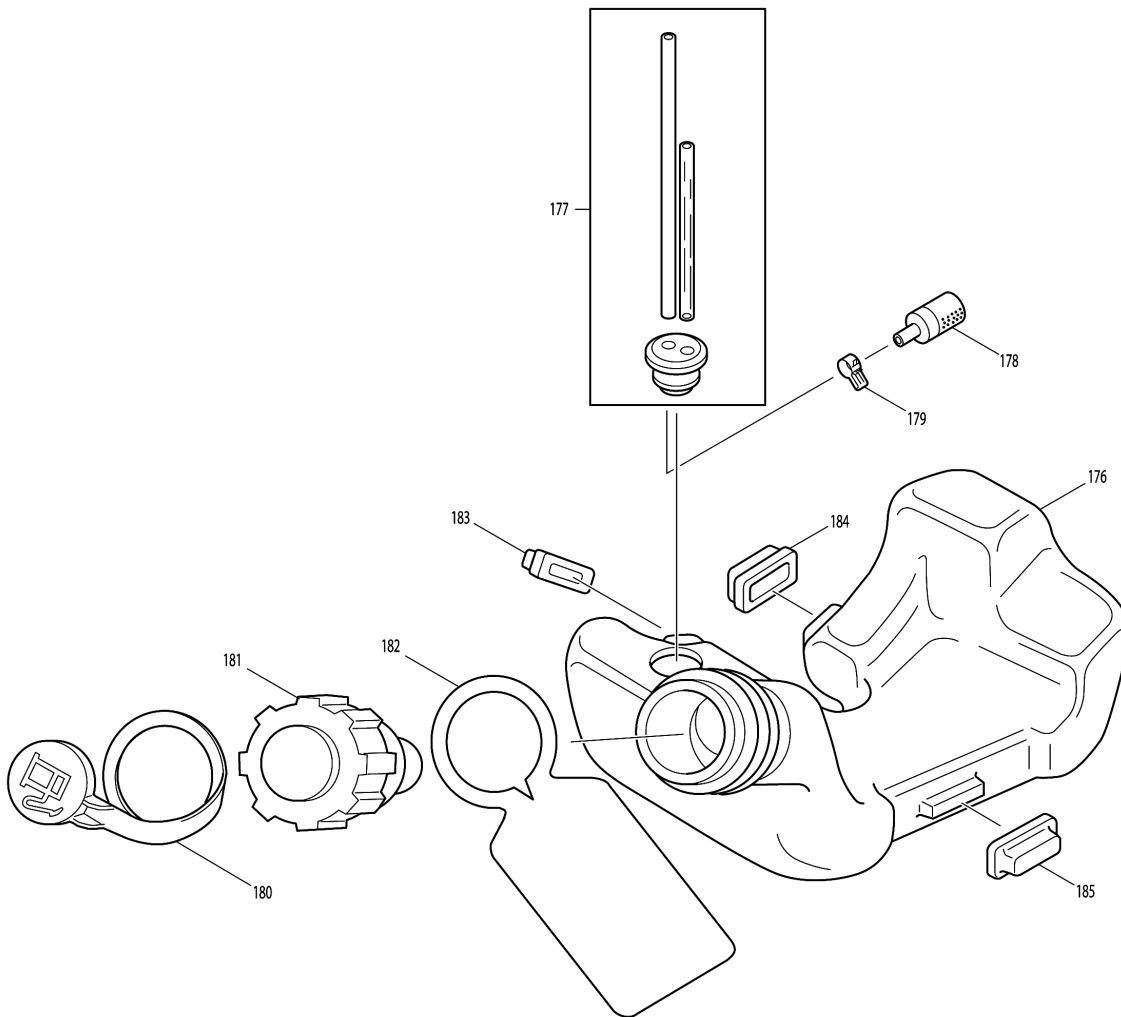

Model No.BCX2510 STRING TRIMMER

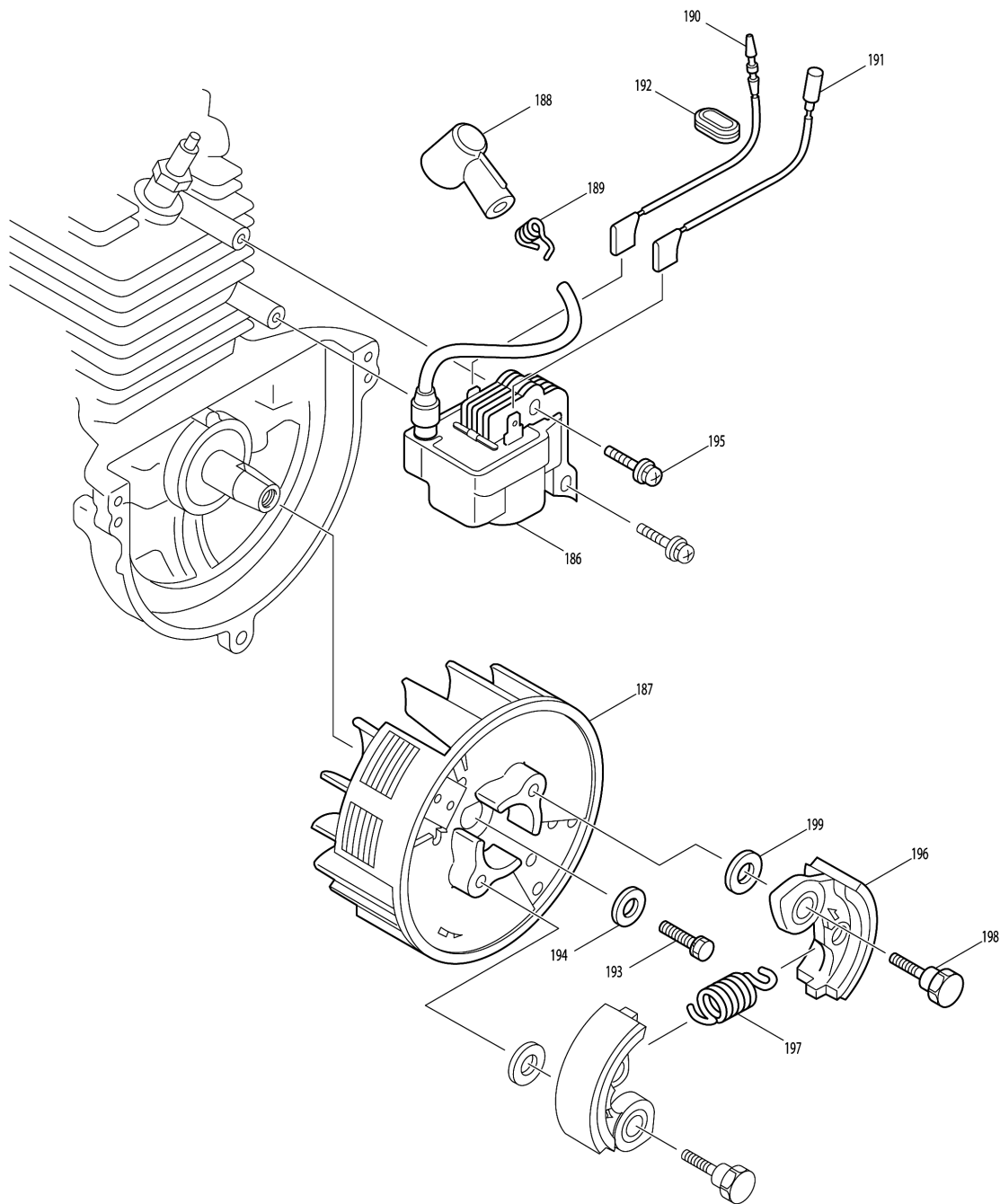

Model No.BCX2510 STRING TRIMMER

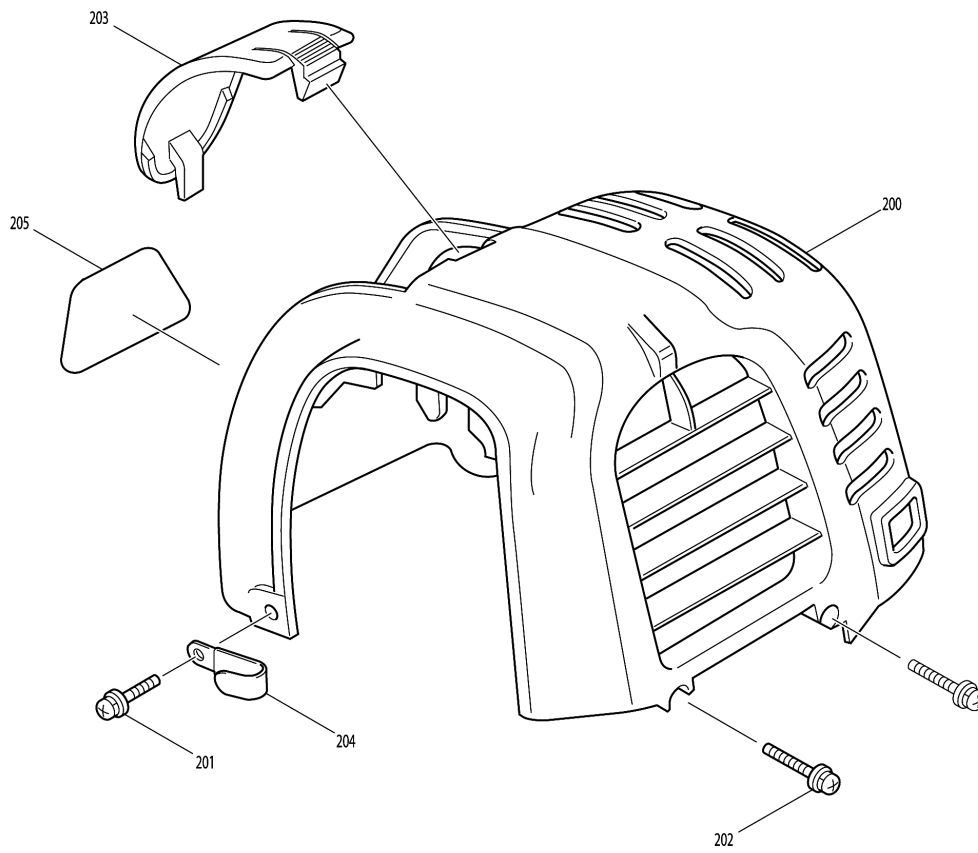

Model No.BCX2510 STRING TRIMMER

Item	Parts No.	Description	I/C	Qty	New/Old	Opt. 1	Opt. 2	Note
050	5921005003	CYLINDER BLOCK SET		1	*			
050-1	5921005004	CYLINDER BLOCK SET	O	1	*			
050-2	5921024000	CYLINDER BLOCK SET	S	1	*			
050-3	5921024000	CYLINDER BLOCK SET	O	1	*			
050-4	5921042000	CYLINDER BLOCK SET	S	1				
D10		INC. 60,61,95,211						
052	5921500502	CAMGEAR COVER		1	*			
052-1	318443-5	CAM GEAR COVER	O	1				
053	5921004000	ROCKER COVER COMPLETE		1	*			
053-1	5921004001	ROCKER COVER COMPLETE	O	1	*			
053-2	140023-7	ROCKER COVER COMPLETE	O	1	*			
053-3	140B46-7	ROCKER COVER COMPLETE	<	1				
054	5921500700	CAMGEAR COVER GASKET		1	*			
054-1	162274-2	CAM GEAR COVER GASKET	O	1				
055	5921500800	ROCKER COVER GASKET		1	*			
055-1	162275-0	ROCKER COVER GASKET	O	1				
056	5921501000	REED VALVE		1	*			
056-1	346083-9	LEAD VALVE	O	1				
057	5921501100	RETAINER PLATE		1	*			
057-1	318440-1	RETAINER PLATE	O	1				
058	0119049980	SOCKET HEAD BOLT M4X10		1				
059	0043605160	SCREW ASS'Y M5X16 (W,SW)		3	*			
059-1	266494-1	+ PAN HEAD SCREW M5X16	O	3				
060	0119059510	SOCKET HEAD BOLT M5X14		6	*			
060-1	0119059510	SOCKET HEAD BOLT M5X14	O	6	*			
060-2	266811-5	H.S.H.BOLT M5X14	O	6				
061	0119059500	SOCKET HEAD BOLT M5X30 (W)		2	*			
061-1	0119059510	SOCKET HEAD BOLT M5X14	O	2	*			
061-2	0119059510	SOCKET HEAD BOLT M5X14	O	2	*			
061-3	266811-5	H.S.H.BOLT M5X14	O	2				
062	0043605140	SCREW ASS'Y M5X14		3				
063	6241500203	CLUTCH CASE		1				
064	0043605160	SCREW ASS'Y M5X16 (W,SW)		3	*			
064-1	266494-1	+ PAN HEAD SCREW M5X16	O	3				
065	5926500000	OIL CASE		1	*			
065-1	318442-7	OIL CASE	O	1				
066	5926500100	CASE GASKET		1	*			
066-1	162276-8	CASE GASKET	O	1				
067	5926500200	OIL TUBE		1	*			
067-1	424202-8	OIL TUBE	O	1				
068	5926500300	OIL WEIGHT		1	*			
068-1	325666-8	OIL WEIGHT	O	1				

Please order the parts with part number.

Print Date 19/6/2019

Model No.BCX2510 STRING TRIMMER

Item	Parts No.	Description	I/C	Qty	New/Old	Opt. 1	Opt. 2	Note
069	5926500600	OIL GAUGE		1	*			
069-1	450565-6	OIL GAUGE	O	1				
070	0213160020	GASKET 16DX23X1.2T		1	*			
070-1	0213169990	GASKET	O	1	*			
070-2	424100-6	GASKET	O	1				
071	0043605180	SCREW ASS'Y M5X18		4	*			
071-1	0119059510	SOCKET HEAD BOLT M5X14	O	4	*			
071-2	266811-5	H.S.H.BOLT M5X14	O	4				
072	0650109950	SPARK PLUG CMR6A		1	*			
072-1	168401-9	SPARK PLUG	O	1				
074	6242003000	CLUTCH DRUM COMPLETE		1	*			
074-1	168475-0	CLUTCH DRUM	O	1				
075	0031432000	INNER SNAP RING		1	*			
075-1	962151-6	RETAINING RING R-32	O	1				
076	0600129810	BALL BEARING		1	*			
076-1	210111-5	BALL BEARING 6201LLU	O	1				
077	0031512000	OUTER SNAP RING		1	*			
077-1	961052-5	RETAINING RING S-12	O	1				
078	6241500300	SPACER		1	*			
078-1	450569-8	SPACER	O	1	*			
078-2	450569-8	SPACER	O	1				
079	6241500401	PIPE DAMPER 1		1	*			
079-1	424191-7	PIPE DAMPER 1	O	1				
080	6241500501	PIPE DAMPER 2		1	*			
080-1	424107-2	PIPE DAMPER 2	O	1				
081	6241500600	PIPE BRACKET 1		1	*			
081-1	6241500601	PIPE BRACKET 1	O	1				
082	6241500700	PIPE BRACKET 2		1	*			
082-1	6241500701	PIPE BRACKET 2	O	1	*			
082-2	318271-8	PIPE BRACKET 2	O	1				
083	0119059900	SOCKET HEAD BOLT M5X12		1				
084	0119059950	SOCKET HEAD BOLT M5X18		2	*			
084-1	266844-0	HEX. S.H.BOLT M5X18 WITH W	O	2				
085	5219002000	STAND SET		1	*			
D10		INC. 86			*			
085-1	195144-0	STAND SET	O	1				
D10		INC. 86						
086	0140059480	SCREW ASS'Y M5X14		2	*			
086-1	266809-2	P.H.SCREW M5X14 WITH WR	O	2				
087	5922003000	CRANK SHAFT ASS'Y		1	*			
087-1	135374-1	CRANKSHAFT ASSEMBLY	O	1	*			
087-2	135539-5	CRANKSHAFT ASSEMBLY	O	1				

Please order the parts with part number.

Print Date 19/6/2019

Model No.BCX2510 STRING TRIMMER

Item	Parts No.	Description	I/C	Qty	New/Old	Opt. 1	Opt. 2	Note
088	0440129960	OIL SEAL (L)		1	*			
088-1	213147-3	OIL SEAL 12	O	1	*			
088-2	213089-1	OIL SEAL 12	<	1				
089	0440109970	OIL SEAL (S)		1	*			
089-1	213148-1	OIL SEAL 10	O	1	*			
089-2	213769-9	OIL SEAL 10	<	1				
090	5421500500	CLIP		1	*			
090-1	267400-9	FLAT WASHER 23	O	1				
091	5922500900	PISTON		1	*			
091-1	318441-9	PISTON	O	1				
092	5922004000	PISTON RING SET		1	*			
092-1	195145-8	PISTON RING SET	O	1				
093	0565089970	CLIP		2	*			
093-1	233976-8	CLIP	O	2				
094	5232502600	PISTON PIN		1	*			
094-1	257781-9	PISTON PIN	O	1				
095	5921501400	SPACER		2	*			
095-1	5921501400	SPACER	O	2	*			
095-2	424200-2	SPACER	O	2				
096	5923500001	CAM LIFTER		2	*			
096-1	313169-4	CAM LIFTER	O	2				
097	5923007000	CAM GEAR ASS'Y		1	*			
097-1	5933003000	CAM GEAR ASS'Y	S	1	*			
097-2	125552-1	CAM GEAR ASSEMBLY	O	1				
098	5923500501	CAM GEAR SHAFT		1	*			
098-1	268238-5	PIN 5	O	1				
099	5923500600	CAM LIFTER SHAFT		1	*			
099-1	268239-3	PIN 4	O	1				
100	5923500700	PUSH ROD		2	*			
100-1	256865-0	ROD 2.5	O	2				
101	5933002000	ROCKER ARM ASS'Y		2	*			
101-1	125554-7	ROCKER ARM ASSEMBLY	O	2				
102	5933500100	ROCKER SHAFT		1	*			
102-1	256200-2	PIN 5	O	1				
103	5923501200	VALVE SPRING		2	*			
103-1	234108-0	COMPRESSION SPRING 9	O	2				
104	5923501300	SPRING RETAINER		2	*			
104-1	325668-4	SPRING RETAINER	O	2				
105	5923501400	EXHAUST VALVE		1	*			
105-1	325669-2	EXHAUST VALVE	O	1	*			
105-2	326366-3	EXHAUST VALVE	O	1				
106	5923501500	INTAKE VALVE		1	*			

Please order the parts with part number.

Print Date 19/6/2019

Model No.BCX2510 STRING TRIMMER

Item	Parts No.	Description	I/C	Qty	New/Old	Opt. 1	Opt. 2	Note
106-1	325670-7	INTAKE VALVE	O	1	*			
106-2	326367-1	INTAKE VALVE	O	1				
107	5925001001	STARTER COVER ASS'Y		1	*			
D10		INC. 108-115			*			
107-1	5925001002	STARTER COVER ASS'Y	O	1	*			
D10		INC. 108-115			*			
107-2	125917-7	STARTER COVER ASSY	O	1				
D10		INC. 108-115						
108	5925001030	REEL		1	*			
108-1	451937-8	REEL	O	1				
109	5195002060	SET SCREW		1	*			
109-1	266585-8	TAPPING SCREW 5X12	O	1				
110	5215002030	SPIRAL SPRING		1	*			
110-1	232258-5	SPIRAL SPRING	O	1				
111	5195002110	COLLAR		1	*			
111-1	451938-6	COLLAR	O	1				
112	5195002100	SWING ARM		1	*			
112-1	325923-4	SWING ARM	O	1				
113	5925001050	STARTER ROPE		1	*			
113-1	444019-3	STARTER ROPE	O	1				
114	5225004020	HANDLE		1	*			
114-1	424319-7	STARTER KNOB	O	1				
115	5195500000	PULLEY		1	*			
115-1	168483-1	PULLEY	O	1				
116	0043604250	SCREW ASS'Y M4X25		2				
117	0230049940	SPACER		2	*			
117-1	331835-1	SPACER	O	2				
118	5929500800	TANK GUARD		1	*			
118-1	345964-4	TANK GUARD	O	1				
119	0043605100	SCREW ASSEMBLY		2	*			
119-1	911208-0	PAN HEAD SCREW M5X10	O	2				
120	6249506900	MODEL LABEL		1				
121	5926009000	CARBURETOR		1	*			
D10		INC. 122-133,135,137-139			*			
121-1	168497-0	CARBURETOR	O	1				
D10		INC. 122-133,135,137-139						
122	5926002060	PUMP BODY ASS'Y		1	*			
D10		INC. 140			*			
122-1	5926002140	PUMP BODY ASS'Y	O	1	*			
D10		INC. 140			*			
122-2	140437-0	PUMP BODY	O	1				
D10		INC. 140						

Please order the parts with part number.

Print Date 19/6/2019

Model No.BCX2510 STRING TRIMMER

Item	Parts No.	Description	I/C	Qty	New/Old	Opt. 1	Opt. 2	Note
123	5236046140	AIR PURGE BODY ASS'Y		1	*			
123-1	140438-8	AIR PURGE BODY	O	1				
124	5236046050	PRIMER PUMP COVER		1	*			
124-1	346270-0	PRIMER PUMP COVER	O	1				
125	5246001150	PRIMER PUMP		1	*			
125-1	424314-7	PRIMER PUMP	O	1				
126	5316005250	METERING DIAPHRAGM ASS'Y		1	*			
126-1	5926008010	METERING DIAPHRAGM ASS'Y	O	1	*			
126-2	168574-8	METERING DIAPHRAGM	O	1	*			
126-3	WJ00963279	SCREW	O	1	*			
126-4	WJ00095586	DIAPHRAGM ASS'Y	X	1				
127	5236046040	METERING DIAPHRAGM GASKET		1	*			
127-1	442154-1	METERING DIAPHRAGM GASKET	O	1				
128	5246001040	PUMP DIAPHRAGM		1	*			
128-1	168575-6	PUMP DIAPHRAGM	O	1	*			
128-2	WJ00009599	PUMP DIAPHRAGM	O	1				
129	5926002040	PUMP GASKET		1	*			
129-1	442155-9	PUMP GASKET	O	1				
130	5196002020	JET		1	*			
130-1	325924-2	JET	O	1				
131	5246001010	O RING		1	*			
131-1	213538-8	O RING 2	O	1				
132	5316005120	RING		1	*			
132-1	257964-1	STOP RING E-3	O	1				
133	5236018040	SWIVEL		1	*			
133-1	325922-6	SWIVEL	O	1				
135	5206008030	PAN HEAD SCREW		2	*			
135-1	266581-6	PAN HEAD SCREW M3X8 WITH W	O	2	*			
135-2	WJ00096364	SCREW M3X8 WITH WASHER	O	2				
137	5236046010	PUMP COVER SCREW		4	*			
137-1	266582-4	TAPPING SCREW 3X24	O	4				
138	5926002020	PUMP SPRING		1	*			
138-1	234183-6	CONICAL COMPRESSION SPRING 5-9	O	1				
139	5426005030	WASHER		1	*			
139-1	413140-9	WASHER	O	1				
140	5016004010	INLET SCREEN		1	*			
140-1	352010-6	INLET SCREEN	O	1	*			
140-2	WJ00014070	INLET SCREEN	O	1				
141	5923005000	INSULATOR		1	*			
D10		INC. 142,143			*			

Please order the parts with part number.

Print Date 19/6/2019

Model No.BCX2510 STRING TRIMMER

Item	Parts No.	Description	I/C	Qty	New/Old	Opt. 1	Opt. 2	Note
141-1	5923005001	INSULATOR COMPLETE	O	1	*			
D10		INC. 142,143			*			
141-2	5923005002	INSULATOR COMPLETE	O	1	*			
D10		INC. 142,143			*			
141-3	5923016000	INSULATOR COMPLETE	S	1	*			
141-4	450559-1	INSULATOR	O	1				
142	0021705000	NUT M5		2	*			
143	0022706000	NUT M6		1	*			
144	0022706000	NUT M6		1	*			
145	5923501801	INSULATOR GASKET		1	*			
145-1	5923504700	INSULATOR GASKET	S	1	*			
145-2	413120-5	INSULATOR GASKET	O	1				
146	5923501900	CARBURETOR GASKET		1	*			
146-1	5923504000	CARBURETOR GASKET	O	1	*			
146-2	413121-3	CARBURETOR GASKET	O	1				
147	5923502000	CARBURETOR INSULATOR		1	*			
148	0043605180	SCREW ASS'Y M5X18		2	*			
148-1	0119059870	SOCKET HEAD BOLT M5X18	O	2	*			
148-2	266787-6	H.S.H.BOLT M5X18 WITH WR	O	2				
149	0149069970	ADJUST SCREW M6X16		1	*			
149-1	0149069972	ADJUST SCREW	O	1	*			
149-2	325934-9	ADJUST SCREW	O	1				
150	5246004150	CAP		1				
152	5921500900	BREATHER PIPE		1	*			
152-1	422041-0	BREATHER PIPE	O	1				
153	5923004001	CLEANER PLATE ASS'Y		1	*			
D10		INC. 154-162			*			
153-1	5923004002	CLEANER PLATE	O	1	*			
D10		INC. 154-162			*			
153-2	5923004003	CLEANER PLATE	S	1	*			
D10		INC. 154-162,213			*			
153-3	5933001000	CLEANER PLATE ASS'Y	S	1	*			
D10		INC. 154-162,213			*			
153-4	125468-0	CLEANER PLATE ASSEMBLY	O	1				
D10		INC. 154-162,213						
154	5923006000	AIR CLEANER PLATE COMPLETE		1	*			
154-1	5923006001	AIR CLEANER PLATE COMPLETE	O	1	*			
154-2	5923006002	AIR CLEANER PLATE COMPLETE	S	1	*			
154-3	5933005000	AIR CLEANER PLATE COMPLETE	S	1	*			
154-4	140814-6	AIR CLEANER PLATE COMPLETE	O	1				

Please order the parts with part number.

Print Date 19/6/2019

Model No.BCX2510 STRING TRIMMER

Item	Parts No.	Description	I/C	Qty	New/Old	Opt. 1	Opt. 2	Note
155	5316500701	CHECK VALVE		1	*			
156	5923502400	CHECK VALVE (1)		1	*			
156-1	424316-3	CHECK VALVE	O	1				
157	5923502500	CHECK VALVE PLATE		1	*			
157-1	451924-7	CHECK VALVE PLATE	O	1				
158	5923503300	SEPARATOR PLATE		1	*			
158-1	5933501600	SEPARATOR PLATE	S	1	*			
158-2	168576-4	SEPARATOR PLATE	O	1				
159	5923502200	CHOKE LEVER		1	*			
159-1	451925-5	CHOKE LEVER	O	1				
160	5923503200	AIR CLEANER ELEMENT		1	*			
160-1	5933501200	AIR CLEANER ELEMENT	S	1	*			
160-2	443141-3	AIR CLEANER ELEMENT	O	1				
161	0240139970	O RING P14		1	*			
161-1	213539-6	O RING 14	O	1				
162	0240159990	O RING P15		1	*			
162-1	213540-1	O RING 15	O	1				
163	5923502300	CHOKE PLATE		1	*			
163-1	5923502301	CHOKE PLATE	O	1	*			
163-2	450560-6	CHOKE PLATE	O	1				
164	5923502600	PLATE		1	*			
164-1	345919-9	PLATE	O	1				
165	0213069990	GASKET		1	*			
165-1	423376-2	GASKET	O	1				
166	5923502700	AIR CLEANER COVER		1	*			
166-1	5933500800	AIR CLEANER COVER	S	1	*			
166-2	450561-4	AIR CLEANER COVER	O	1				
167	5923503001	PIPE		1	*			
167-1	422042-8	PIPE	O	1				
168	0140059480	SCREW ASS'Y M5X14		1	*			
168-1	266809-2	P.H.SCREW M5X14 WITH WR	O	1				
169	5923503100	SCREW M5X68 (W,SW SUS)		2	*			
169-1	265188-5	+PAN HEAD SCREW M5X68	O	2				
170	0561080010	HOSE CLAMP		1	*			
170-1	345918-1	HOSE CLAMP	O	1				
171	5923001000	EXHAUST MUFFLER		1	*			
171-1	168469-5	EXHAUST MUFFLER	O	1				
172	5923501601	MUFFLER GASKET		1	*			
172-1	345916-5	MUFFLER GASKET	O	1				
173	5923503400	MUFFLER COVER		1	*			
173-1	345915-7	MUFFLER COVER	O	1				
174	0119059520	SOCKET HEAD BOLT M5X40		2	*			

Please order the parts with part number.

Print Date 19/6/2019

Model No.BCX2510 STRING TRIMMER

Item	Parts No.	Description	I/C	Qty	New/Old	Opt. 1	Opt. 2	Note
174-1	266440-4	HEX SOCKET HEAD BOLT M5X40	O	2				
175	0140059962	SCREW M5X5		1				
176	5926500400	FUEL TANK		1	*			
176-1	450566-4	FUEL TANK	O	1				
177	5926003000	TUBE		1	*			
177-1	168472-6	TUBE COMPLETE	O	1				
178	5236503900	FILTER		1	*			
178-1	163447-0	FUEL FILTER	O	1	*			
178-2	163447-0	FUEL FILTER	O	1				
179	0561059990	HOSE CLAMP		1	*			
179-1	345920-4	HOSE CLAMP	O	1				
180	5926006001	FUEL TANK CAP ASS'Y		1	*			
180-1	5926012000	FUEL TANK CAP	S	1				
181	5926005000	STRAP UNIT		1	*			
181-1	5256067000	STRAP	S	1	*			
181-2	140436-2	STRAP COMPLETE	O	1				
182	6249501501	STRAP		1	*			
182-1	810455-9	CAUTION PLATE	<	1				
183	5036500200	PLATE		1	*			
183-1	424102-2	PLATE	O	1				
184	5036500300	PLATE		1	*			
184-1	424103-0	PLATE	O	1				
185	5196500301	DAMPER		1	*			
185-1	5196500302	DAMPER	O	1	*			
185-2	424104-8	DAMPER	O	1				
186	5927001010	IGNITION COIL		1	*			
186-1	5927012010	IGNITION COIL	O	1	*			
186-2	5927012011	IGNITION COIL	O	1	*			
186-3	168501-5	IGNITION COIL	O	1				
187	5927001020	FLYWHEEL		1	*			
187-1	5927001021	FLYWHEEL	O	1	*			
187-2	318343-9	FLYWHEEL	O	1				
188	5927500100	PLUG CAP		1	*			
188-1	424105-6	PLUG CAP	O	1				
189	0654009931	PLUG CAP SPRING		1	*			
189-1	324891-8	PLUG CAP SPRING	O	1				
190	5927003000	WIRE COMPLETE		1	*			
190-1	638664-6	LEAD UNIT	O	1				
191	5257018001	WIRE COMPLETE		1	*			
191-1	638665-4	LEAD UNIT	O	1				
192	5257500300	GROMMET		1	*			
193	0011306160	BOLT ASS'Y		1				

Please order the parts with part number.

Print Date 19/6/2019

Model No.BCX2510 STRING TRIMMER

Item	Parts No.	Description	I/C	Qty	New/Old	Opt. 1	Opt. 2	Note
194	0031206000	WASHER		1				
195	0140049920	SCREW ASS'Y M4X20		2				
196	5928500000	CLUTCH SHOE		2				
197	5928500100	SPRING		1				
198	5928500200	CLUTCH BOLT		2				
199	5928500300	WASHER		2	*			
199-1	267812-6	WASHER 6	O	2				
200	5925500800	CYLINDER COVER		1				
201	0043605100	SCREW ASSEMBLY		2	*			
201-1	911208-0	PAN HEAD SCREW M5X10	O	2				
202	0043604160	SCREW M4X16(W,SW)		2				
203	5927500000	PLUG COVER		1	*			
203-1	450568-0	PLUG COVER	O	1				
204	0566059980	CLAMP		1	*			
204-1	345963-6	CLAMP	O	1				
205	5929501001	TRADE MARK LABEL		1				
208	6258042002	PROTECTOR COMPLETE		1	*			
208-1	6258042005	PROTECTOR COMPLETE	O	1	*			
210	5923503900	PIPE		1	*			
211	5921501800	CHECK VALVE		2	*			
211-1	5921501800	CHECK VALVE	O	2	*			
211-2	424201-0	CHECK VALVE	O	2				
212	0043605100	SCREW ASSEMBLY		1	*			
212-1	0119059780	SOCKET HEAD BOLT M5X12	O	1	*			
212-2	922213-2	H.S.H.BOLT M5X12 WITH WR	O	1				
213	5923503500	GASKET SEPARATOR		1	*			
213-1	168577-2	SEPARATOR GASKET	O	1				
214	5933500900	AIR CLEANER ELEMENT		1	*			
214-1	443140-5	AIR CLEANER ELEMENT	O	1				
215	5923504600	INTAKE PIPE		1	*			
215-1	324961-3	INTAKE PIPE	O	1				
216	0062610101	O RING		1				
A01	6247001001	BAND ASS'Y		1	*			
A01-1	123143-2	BAND ASSEMBLY	O	1				
C10	6347004000	HOOK		1	*			
C11	168578-0	HOOK	O	1				
A02	B-01878	STAR BLADE 230-4T		1	*			
A02-1	B-14118	STAR BLADE 230X4TX25.4	<	1				
A03	6418500701	CUTTER COVER		1	*			
A03-1	6418027000	CUTTER COVER	O	1	*			
A03-2	456924-2	TOOL COVER	O	1				
A04	6249000000	TOOL SET		1	*			

Please order the parts with part number.

Print Date 19/6/2019

Model No.BCX2510 STRING TRIMMER

Item	Parts No.	Description	I/C	Qty	New/Old	Opt. 1	Opt. 2	Note
A04-1	196194-8	TOOL SET	O	1				
A05-1	0722104600	OIL BOTTLE		1				
A06	6111502700	WIRE CLAMP		2	*			
A06-1	450563-0	CLAMP	O	2				

Please order the parts with part number.

Print Date 19/6/2019