

Model No.AR410HR AIR SCREW DRIVER

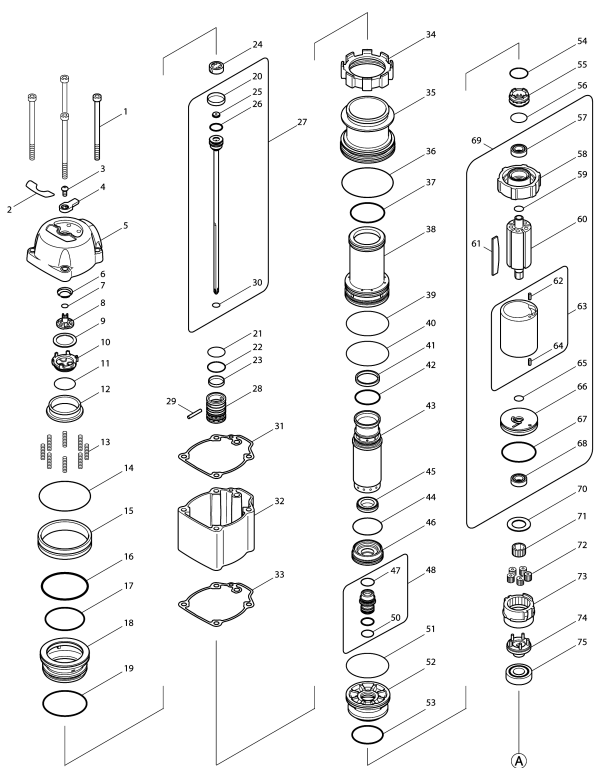

Model No.AR410HR AIR SCREW DRIVER

Item	Parts No.	Description	I/C	Qty	New/Old	Opt. 1	Opt. 2	Note
001	266431-5	HEX SOCKET HEAD BOLT M5X80		4				
002	816897-5	INDICATION LABEL		1				
003	266430-7	H.S. BUTTON HEAD BOLT M4X8		1				
004	450334-5	KNOB		1				
005	318233-6	TOP CAP		1				
006	233962-9	CONICAL COMPRESSION SPRING 10-15		1				
007	213045-1	O-RING 6		1				
008	162263-7	CHANGE VALVE		1				
009	267365-5	FLAT WASHER 19		1				
010	424149-6	REAR CUSHION		1				
011	213373-4	O RING 22		1				
012	424072-5	SEAL RING		1				
013	234079-1	COMPRESSION SPRING 4		8				
014	213496-8	O-RING 54		1				
015	331851-3	CYLINDER STAY		1				
016	213145-7	O RING 47		1				
017	213143-1	O RING 40		1				
018	450306-0	HEAD VALVE		1				
019	213144-9	O-RING 45		1				
020	262146-2	RUBBER RING 16		1				
021	213265-7	O RING 17		1				
022	213275-4	O RING 18		1				
023	262145-4	RUBBER RING 16		1				
024	324951-6	PISTON CAP		1				
025	424151-9	REAR CUSHION		1				
026	213140-7	O-RING 11		1				
027	194708-7	DRIVER BIT SET		1	*			
C10	424168-2	URETHANE RING		1	*			
D10		INC. 20,25,26,30			*			
027-1	195873-5	DRIVER BIT SET	<	1				
C10	424502-6	URETHANE RING		1				
D10		INC. 20,25,26,30						
028	325592-1	MAIN PISTON		1				
029	268227-0	PIN 3		1				
030	213026-5	O RING 7		1				
031	162260-3	TOP CAP GASKET		1				
032	318235-2	TOP CAP SPACER		1	*			
032-1	318859-4	TOP CAP SPACER	<	1				
033	162260-3	TOP CAP GASKET		1				
034	424073-3	CYLINDER SEAL		1				
035	450304-4	OUTER CYLINDER		1				

Model No.AR410HR AIR SCREW DRIVER

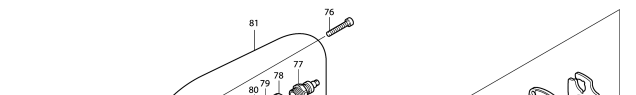

Model No.AR410HR AIR SCREW DRIVER

Item	Parts No.	Description	I/C	Qty	New/Old	Opt. 1	Opt. 2	Note
036	213496-8	O-RING 54		1				
037	213497-6	O-RING 31.5		1				
038	450303-6	SEPARATOR		1				
039	213495-0	O-RING 45		1				
040	213495-0	O-RING 45		1				
041	262140-4	RUBBER RING 23		1				
042	213987-9	O-RING 25		1				
043	331845-8	CYLINDER		1				
044	213989-5	O-RING 30		1				
045	424171-3	CUSHION RING		1				
046	324949-3	CUSHION GUIDE		1				
047	213185-5	O-RING 12.5		1				
048	135211-9	FRONT CUSHION ASS'Y		1				
D10		INC. 47,50						
050	213118-0	O RING 12		1				
051	213495-0	O-RING 45		1				
052	450302-8	OUTER SEPARATOR		1				
053	213990-0	O-RING 31.5		1				
054	213261-5	O RING 17		1				
055	450301-0	INNER SEPARATOR		1				
056	213223-3	O RING 16		1				
057	211099-2	BALL BEARING 689ZZ		1				
058	450300-2	UPPER DRUM CAP		1				
059	213062-1	O RING 9		1				
060	324855-2	ROTER		1				
061	413117-4	BLADE		5				
062	258024-2	SPRING PIN 2.5-5		1				
063	135193-5	DRUM ASSY		1				
D10		INC. 62,64						
064	258024-2	SPRING PIN 2.5-5		1				
065	213062-1	O RING 9		1				
066	450299-1	LOWER DRUM CAP		1				
067	213991-8	O-RING 35		1				
068	211099-2	BALL BEARING 689ZZ		1				
069	135194-3	AIR MOTOR ASS'Y		1				
D10		INC. 57-61,63,65-68						
070	267215-4	FLAT WASHER 15		1				
071	227186-7	SPUR GEAR 21		1				
072	227187-5	SPUR GEAR 10		5				
073	227185-9	INTERNAL SPUR GEAR 44		1				
074	158512-8	CARRIER COMPLETE		1				
075	211138-8	BALL BEARING 6001LLU		1				

Model No.AR410HR AIR SCREW DRIVER

Item	Parts No.	Description	I/C	Qty	New/Old	Opt. 1	Opt. 2	Note
076	922252-2	HEX SOCKET HEAD BOLT M5X30		4				
077	243106-3	PLUG		1				
078	266281-2	CAP 9		1				
079	233961-1	CONICAL COMPRESSION SPRINGS-10		1				
080	424075-9	SHEET PACKING		1				
081	135190-1	INLET CAP ASSY		1				
D10		INC. 77-80,82						
082	213987-9	O-RING 25		1				
083	413119-0	FILTER		1				
084	450311-7	INLET CAP SPACER		1				
085	162261-1	INLET CAP GASKET		1				
086	213162-7	O RING 14		1				
087	213154-6	O RING 14		1				
088	413124-7	INLET FILTER		1				
089	331803-4	PIPE 13		1				
090	213162-7	O RING 14		1				
091	188677-2	HOUSING SET		1				
D10		INC. 98,100,101						
092	866088-8	AR410HR NAME PLATE		1				
093	265176-2	PAN.HD.SCREW M5X22		1				
094	419843-3	HOOK		1				
095	931202-6	HEX NUT M5		1				
096	162255-6	HOOK BASE		1				
097	951075-1	SPRING PIN 3-28		2				
098	819330-6	MAKITA ROGO LABEL R		1				
099	961011-9	STOP RING E-4		1				
100	819331-4	MAKITA ROGO LABEL L		1				
101	816918-3	INDICATION LABEL		1				
102	216008-6	STEEL BALL 4		1				
103	231236-2	COMPRESSION SPRING 3		1				
104	162189-3	LOCK PIN 6		1				
105	962103-7	RETAINING RING R-24		1				
106	345781-2	CUP WASHER		1				
107	234046-6	COMPRESSION SPRING 10		1				
108	234045-8	COMPRESSION SPRING 9		1				
109	262123-4	RUBBER RING 14		1				
110	213971-4	O-RING 19		1				
111	324854-4	FEED PINTON		1	*			
111-1	326115-8	FEED PISTON	<	1				
112	262130-7	URETHANE RING 4		1				
113	213007-9	O RING 8		1				

Please order the parts with part number.

Print Date 5/10/2020

Model No.AR410HR AIR SCREW DRIVER

Item	Parts No.	Description	I/C	Qty	New/Old	Opt. 1	Opt. 2	Note
114	234042-4	COMPRESSION SPRING 3		1				
115	310246-3	FEEDING CLAW		1				
116	268193-1	PIN 4.5		1				
117	158515-2	DRIVER GUIDE COMPLETE		1				
118	162262-9	DRIVER GUIDE GASKET		1				
119	266086-6	HEX SOCKET HEAD BOLT M5X16		1				
120	451254-6	CONTACT ARM COVER		1				
121	922212-4	HEX SOCKET HEAD BOLT M5X12		2				
122	310217-0	LOCK PIN		1				
123	234003-4	COMPRESSION SPRING 5		1				
124	419814-0	DOOR		1				
125	262120-0	URETHANE RING 3		1				
126	262120-0	URETHANE RING 3		1				
127	268174-5	PIN 4		1				
128	922246-7	HEX SOCKET HEAD BOLT M5X28		1				
129	267343-5	FLAT WASHER 5		1				
130	256774-3	PIN 5		1				
131	961011-9	STOP RING E-4		1				
132	135259-1	MAGAZINE ASS'Y		1				
D10		INC. 130,131,133						
133	158909-1	MAGAZINE CAP COMPLETE		1				
C10	808205-4	AR410HR MAGAZINE CAP LABEL		1				
134	450788-6	TRIGGER VALVE GUIDE		1				
135	213275-4	O RING 18		1				
136	450310-9	PILOT VALVE		1				
137	213134-2	O-RING 11		1				
138	213984-5	O-RING 8		1				
139	213985-3	O-RING 8		1				
140	213986-1	O-RING 2		1				
141	234081-4	COMPRESSION SPRING 3		1				
142	324853-6	TRIGGER VALVE STEM		1	*			
142-1	325875-9	TRIGGER VALVE STEM	S	1				
143	213034-6	O RING 3		1				
144	213187-1	O-RING 13.5		1				
145	213310-8	O RING 20		1				
146	450308-6	TRIGGER VALVE CASE		1				
147	344265-7	IDLER		1				
148	450344-2	TRIGGER		1				
149	258004-8	SPRING PIN 2.5-16		1				
150	951075-1	SPRING PIN 3-28		1				

Please order the parts with part number.

Print Date 5/10/2020

<https://msi.makita.co.jp/MSiWW/MSiWW/swf/print.html>

7/9

<https://msi.makita.co.jp/MSiWW/MSiWW/swf/print.html>

8/9

Model No.AR410HR AIR SCREW DRIVER

Item	Parts No.	Description	I/C	Qty	New/Old	Opt. 1	Opt. 2	Note
151	450314-1	HOLDER		1				
152	951075-1	SPRING PIN 3-28		1				
153	234044-0	COMPRESSION SPRING 6		1				
154	310247-1	STOPPER		1				
155	324745-9	ADJUSTER SHAFT		1				
156	233491-2	COMPRESSION SPRING 2		1				
157	216031-1	STEEL BALL 2.3		1				
158	158747-1	ADJUSTER COMPLETE		1				
159	951010-9	SPRING PIN 2-14		1				
160	951010-9	SPRING PIN 2-14		1				
161	310201-5	ADJUSTER PIECE		1				
162	135260-6	CONTACT ARM ASS'Y		1	*			
D10		INC. 154-161,163-169			*			
162-1	135301-8	CONTACT ARM ASSY	S	1				
C10	310419-8	CONTACT ARM		1				
D10		INC. 154-161,163-169						
163	233511-2	TORSION SPRING 4		1				
164	310222-7	CHUCK		1				
165	261118-4	URETHANE WASHER		2				
166	310221-9	CHUCK		1				
167	233511-2	TORSION SPRING 4		1				
168	310220-1	CONTACT TOP		1				
169	268173-7	PIN 3.5		2				
170	424005-0	NOSE ADAPTER		1				
171	194738-8	AIR LEAK REPAIR SET		1				
D10		INC. 16,17,19,37,135,137-140,						
D20		INC. 143-145						
173	135212-7	TRIGGER VALVE ASS'Y		1				
D10		INC. 134-146						
A01	192517-8	SAFETY GOGGLE		1	*			
A01-1	195246-2	SAFETY GOGGLE	<	1	*			
A02	194381-3	OIL SUPPLY SET		1				
A03	194708-7	DRIVER BIT SET		1	*			
A03-1	195873-5	DRIVER BIT SET	<	1				
A04	783202-0	HEX WRENCH 4		1				
A05	824864-6	PLASTIC CARRYING CASE		1				
C10	163455-1	LATCH		2				
C20	419360-3	HANDLE		1				

Please order the parts with part number.

Print Date 5/10/2020

<https://msi.makita.co.jp/MSiWW/MSiWW/swf/print.html>

9/9