

Model No.9047S 180MM ANGLE GRINDER

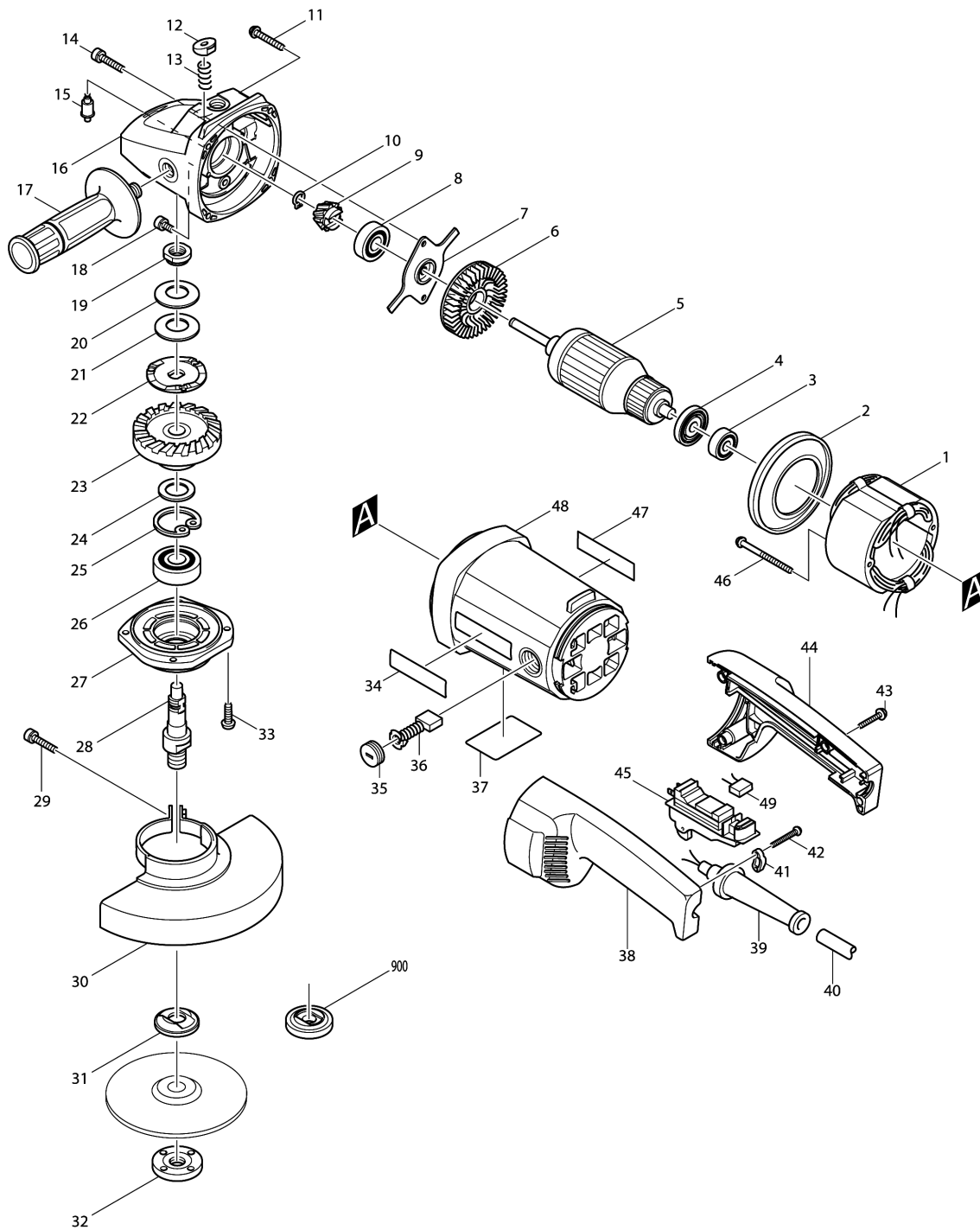

Model No.9047S 180MM ANGLE GRINDER

Item	Parts No.	Description	I/C	Qty	New/Old	Opt. 1	Opt. 2	Note
001B_	526048-9	FIELD ASS'Y 220V		1				
C10	654098-5	RECEPTACLE		2	*			
C11	654208-4	RECEPTACLE	X	2				
002	416131-9	BAFFLE PLATE		1				
003	211087-9	BALL BEARING 6200DDW		1				
004	681630-2	INSULATION WASHER		1				
005B_	516708-1	ARMATURE ASS'Y 220V		1	*			
D10		INC. 3,4,6			*			
005B1	516708-1	ARMATURE ASS'Y 220V	<	1				
D10		INC. 3,4,6						
006	241908-1	FAN 80		1				
007	285832-8	BEARING RETAINER 60		1				
008	211132-0	BALL BEARING 6301DDW		1				
009	226737-3	SPIRAL BEVEL GEAR 16		1				
010	961005-4	RETAINING RING S-9		1				
011A_	266152-9	TAPPING SCREW FLANGE PF 5X35		4	*			
011A1	266012-5	TAPPING SCREW 5X35	O	4				
012	416132-7	PIN CAP		1				
013	233031-6	COMPRESSION SPRING 12		1				
014	266129-4	HEX. SOCKET HEAD BOLT M5X25		1				
015	256445-2	PIN 6		1				
016	159907-8	GEAR HOUSING COMPLETE		1	*			
C10	213515-0	O RING 36		1	*			
016-1	151859-9	GEAR HOUSING COMPLETE	S	1	*			
C10	213515-0	O RING 36		1	*			
C20	212074-1	NEEDLE BEARING 1012		1	*			
016-2	125201-0	GEAR HOUSING ASS'Y	<	1				
C10	213515-0	O RING 36		1				
C20	212074-1	NEEDLE BEARING 1012		1				
C30	151859-9	GEAR HOUSING COMPLETE		1				
D10		INC. 12,13,15						
017	152539-0	GRIP 36 COMPLETE		1				
018	265976-0	HEX.SOCKET HEAD BOLT M5X10		1				
019	252425-6	NUT M15-23		1				
020	232163-6	CUP SPRING 20		1				
021	232163-6	CUP SPRING 20		1				
022	267725-1	LOCK WASHER		1				
023	226738-1	SPIRAL BEVEL GEAR 53		1				
024	267167-9	FLAT WASHER 15		1				
025	962157-4	RETAINING RING R-40		1				
026	211278-2	BALL BEARING 6203DDW		1				

Please order the parts with part number.

Print Date 18/6/2019

Model No.9047S 180MM ANGLE GRINDER

Item	Parts No.	Description	I/C	Qty	New/Old	Opt. 1	Opt. 2	Note
027	316854-8	BEARING BOX		1	*			
027-1	316855-6	BEARING BOX	O	1				
028	322902-3	SPINDLE		1				
029	265050-4	PAN HEAD SCREW M8X25		1				
030	165185-0	WHEEL COVER		1	*			
030-1	165215-7	WHEEL COVER	O	1				
031	224298-7	INNER FLANGE 42		1	*			
031-1	224415-9	INNER FLANGE 42	<	1				
031D_	122444-5	INNER FLANGE 47 ASS'Y		1				
032	224543-0	LOCK NUT 14-45		1				
033	266027-2	TAPPING SCREW CT5X16		4	*			
033-1	911226-8	PAN HEAD SCREW M5X18	X	4	*			
033-2	911230-7	PAN HEAD SCREW M5X18	<	4				
034	819064-1	MAKITA MARK		1				
035	643700-5	BRUSH HOLDER CAP 7-18		2				
036	191957-7	A.C. CARBON BRUSH CB-204		1				
037A_	858598-9	NAME PLATE 9047S		1				
038	182842-5	HANDLE SET		1				
D10		INC. 44						
039A_	682540-6	CORD GUARD 9.3-90		1				
040N_	665630-0	POWER SUPPLY CORD 1.5-2-2.5		1	*			
040N1	695107-1	POWER SUPPLY CORD 1.5-2-2.5	O	1				
041C_	687053-2	STRAIN RELIEF		1				
042A_	266121-0	TAPPING SCREW FLANGE PF 4X18		2	*			
042A1	265995-6	TAPPING SCREW 4X18	O	2				
043A_	266119-7	TAPPING SCREW FLANGE PF 4X25		4	*			
043A1	265999-8	TAPPING SCREW 4X25	O	4				
044	182842-5	HANDLE SET		1				
D10		INC. 38						
045B1	651147-9	SWITCH 1362.0102	O	1	*			
045B2	651178-8	SWITCH 1362.0112	O	1				
046A_	266109-0	TAPPING SCREW FLANGE PF 5X65		2	*			
046A1	266029-8	TAPPING SCREW 5X65	O	2				
047	819064-1	MAKITA MARK		1				
048A_	159952-3	MOTOR HOUSING COMPLETE		1				
C10	643705-5	BRUSH HOLDER		2	*			
C11	643707-1	BRUSH HOLDER	O	2				
049A1	645216-6	NOISE SUPPRESSOR	O	1	*			
049A2	645140-3	NOISE SUPPRESSOR	O	1				
050A_	539121-6	RESISTOR ASS'Y 200/220/240V		1	*			

Please order the parts with part number.

Print Date 18/6/2019

Model No.9047S 180MM ANGLE GRINDER

Item	Parts No.	Description	I/C	Qty	New/Old	Opt. 1	Opt. 2	Note
050A1	539183-4	RESISTOR ASS'Y 200/220/240V	O	1				
051	442129-0	GASKET		1				
A01	782407-9	LOCK NUT WRENCH 35		1				
B01	125060-2	TORQUE LIMITER ASS'Y		1				
D10		INC. 19-28						

Please order the parts with part number.

Print Date 18/6/2019