

### Model No.6836 AUTO FEED SCREWDRIVER

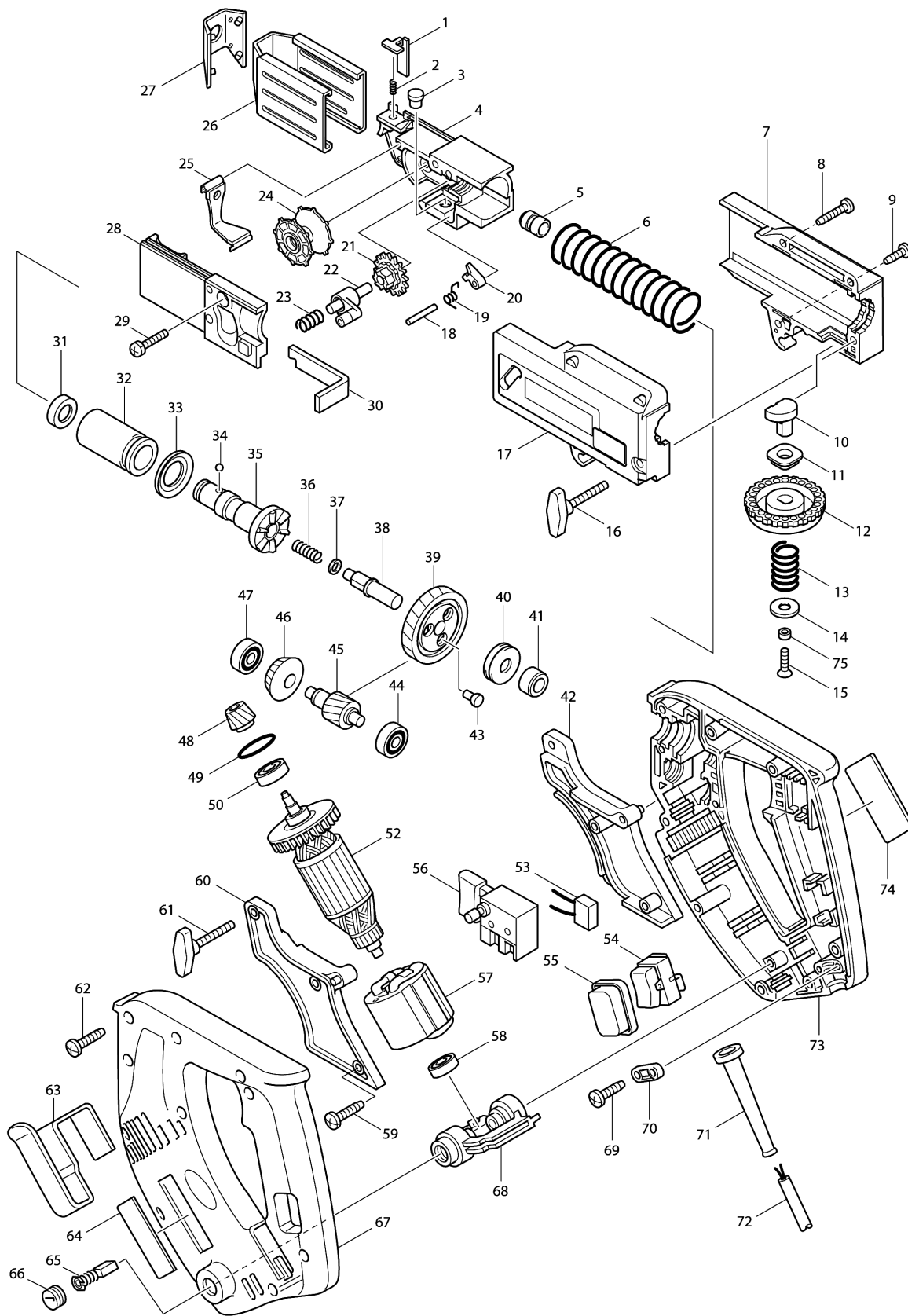



## Model No.6836 AUTO FEED SCREWDRIVER

Item	Parts No.	Description	I/C	Qty	New/Old	Opt. 1	Opt. 2	Note
001	344625-3	LEVER		1				
002	233211-4	COMPRESSION SPRING 2		1				
003	256451-7	PIN 6		1				
004-1	416500-4	FEEDER BOX		1				
005	257687-1	SLEEVE 5		1	*			
005-1	257685-5	SLEEVE 5	S	1				
006	233209-1	COMPRESSION SPRING 21		1				
007	182994-2	CASING SET		1	*			
C10	816282-2	INDICATION LABEL		1	*			
C20	818843-4	INDICATION LABEL		1	*			
C30	818553-3	INDICATION LABEL		1	*			
D10		INC. 17			*			
007-1	188211-8	CASING SET	S	1				
C10	816282-2	INDICATION LABEL		1				
C20	804948-6	INDICATION LABEL		1				
C30	818553-3	INDICATION LABEL		1				
D10		INC. 17						
008	266045-0	TAPPING SCREW 4X20		2				
009	266020-6	TAPPING SCREW 4X12		1				
010	310091-6	SHIFTER PIN		1				
011	257686-3	SLEEVE 8		1				
012	417056-0	DIAL 42		1				
013	213105-9	O RING 11		1				
014	267201-5	FLAT WASHER 6		1				
015	912117-6	COUNTERSUNK HEAD SCREW M4X12		1				
016	265732-8	SCREW M4X28		1	*			
016-1	265778-4	THUMB SCREW M4X28	<	1	*			
016-2	265779-2	THUMB SCREW M4X28	<	1				
017	182994-2	CASING SET		1	*			
C10	816282-2	INDICATION LABEL		1	*			
C20	818843-4	INDICATION LABEL		1	*			
C30	818553-3	INDICATION LABEL		1	*			
D10		INC. 7			*			
017-1	188211-8	CASING SET	S	1				
C10	816282-2	INDICATION LABEL		1				
C20	804948-6	INDICATION LABEL		1				
C30	818553-3	INDICATION LABEL		1				
D10		INC. 7						
018	256158-5	PIN 3		1				
019	231636-6	TORSION SPRING 4		1				
020	310062-3	STOPPER		1				
021	226344-2	SPUR GEAR 16		1				

Please order the parts with part number.

Print Date 18/6/2019

## Model No.6836 AUTO FEED SCREWDRIVER

Item	Parts No.	Description	I/C	Qty	New/Old	Opt. 1	Opt. 2	Note
022	152580-3	RATCHET ARM COMPLETE		1				
023	233212-2	COMPRESSION SPRING 6		1				
024	416518-5	WHEEL		1				
025	162201-9	DUST COVER		1				
026	344628-7	STOPPER BASE		1				
027	421617-0	CAP		1				
028	152581-1	BOX COVER COMPLETE		1				
029	911133-5	PAN HEAD SCREW M4X18		1				
030	344626-1	PLATE		1				
031	421467-3	DUST COVER		1				
032	214168-8	PLANE BEARING 14		1				
033	421618-8	RING 15		1				
034	216001-0	STEEL BALL 3.5		1				
035	323765-0	SPINDLE		1	*			
035-1	153741-8	SPINDLE COMPLETE	S	1				
036	233096-8	COMPRESSION SPRING 5		1	*			
036-1	233393-2	COMPRESSION SPRING 8	S	1				
037	267184-9	FLAT WASHER 6		1	*			
037-1	267277-2	FLAT WASHER 8	S	2				
039	152998-8	GEAR COMPLETE		1	*			
039-1	153736-1	GEAR COMPLETE	S	1	*			
039-2	153761-2	GEAR COMPLETE	O	1				
040	212042-4	THRUST NEEDLE BEARING 821		1				
041	214028-4	PLANE BEARING 8		1				
042	182984-5	SCREW GUIDE SET		1				
D10		INC. 60						
043	256467-2	SHOULDER PIN 4		3	*			
043-1	256479-5	SHOULDER PIN 4	<	3				
044	211014-6	BALL BEARING 606		1				
045	226524-0	HELICAL GEAR 17		1				
046	226705-6	SPIRAL BEVEL GEAR 22		1				
047	211014-6	BALL BEARING 606		1				
048	226704-8	SPIRAL BEVEL GEAR 15		1				
049	213008-7	O RING 22.4		1	*			
049-1	213380-7	O RING 24	<	1				
050	211061-7	BALL BEARING 6000LLB		1				
052	517063-4	ARMATURE ASS'Y 220V		1				
D10		INC. 50,58						
053	645253-0	NOISE SUPPRESSOR		1				
054	651569-3	SWITCH VLX13		1				
055	421621-9	DUST COVER		1				
056	651283-1	SWITCH SGEL208C		1				

Please order the parts with part number.

Print Date 18/6/2019

## Model No.6836 AUTO FEED SCREWDRIVER

Item	Parts No.	Description	I/C	Qty	New/Old	Opt. 1	Opt. 2	Note
057	633258-2	FIELD 220V		1				
058	210025-8	BALL BEARING 627LLB		1				
059	266045-0	TAPPING SCREW 4X20		2				
060	182984-5	SCREW GUIDE SET		1				
D10		INC. 42						
061	265732-8	SCREW M4X28		1	*			
061-1	265778-4	THUMB SCREW M4X28	<	1	*			
061-2	265779-2	THUMB SCREW M4X28	<	1				
062	266045-0	TAPPING SCREW 4X20		10				
063	344056-6	HOOK		1				
064	819063-3	MAKITA LABEL		1				
065	191940-4	CARBON BRUSH CB-411		1				
066	643550-8	BRUSH HOLDER CAP 5-8		2				
067	183173-5	HOUSING SET		1	*			
C10	812532-3	INDICATION LABEL		1	*			
D10		INC. 64,73			*			
067-1	183173-5	HOUSING SET	O	1				
C10	812552-7	INDICATION LABEL		1				
D10		INC. 64,73						
068	152433-6	HOLDER ARM CPMLETE		1				
C10	643932-4	BRUSH HOLDER 6X9		2				
069	265995-6	TAPPING SCREW 4X18		2				
070	687052-4	STRAIN RELIEF		1				
071	682559-5	CORD GUARD 8		1				
072	695034-2	POWER SUPPLY CORD 1.0-2-4.0		1				
073	183173-5	HOUSING SET		1	*			
C10	812532-3	INDICATION LABEL		1	*			
D10		INC. 64,67			*			
073-1	183173-5	HOUSING SET	O	1				
C10	812552-7	INDICATION LABEL		1				
D10		INC. 64,67						
074	860159-3	NAME PLATE 6836		1				
A01	784237-4	PHILLIPS BIT 2-127		3	*			
A01-1	784247-1	+ BIT 2-127	S	3				
A02	824421-0	PLASTIC CARRYING CASE		1				
C10	182935-8	SLIDE LATCH (R.L) SET		1				
B01	193025-2	CASING ASS'Y		1	*			
D10		INC. B02,6-17,30			*			
B01-1	194382-1	CASING SET	S	1				
D10		INC. B02,6-17,30						
B02	192854-0	FEEDER BOX ASS'Y		1	*			
D10		INC. 1-5,18-29			*			

Please order the parts with part number.

Print Date 18/6/2019

## Model No.6836 AUTO FEED SCREWDRIVER

Item	Parts No.	Description	I/C	Qty	New/Old	Opt. 1	Opt. 2	Note
B02-1	192853-2	FEEDER BOX ASS'Y	S	1				
D10		INC. 1-5,18-29						
B03	152676-0	STOPPER BASE COMPLETE		1				
D10		INC. 26,27						
E01	646049-2	CHOKE COIL		1				
E02	646050-7	CHOKE COIL		1				
E03	654015-5	EARTH TERMINAL		1				

Please order the parts with part number.

Print Date 18/6/2019