

Model No.6834 AUTO FEED SCREWDRIVER

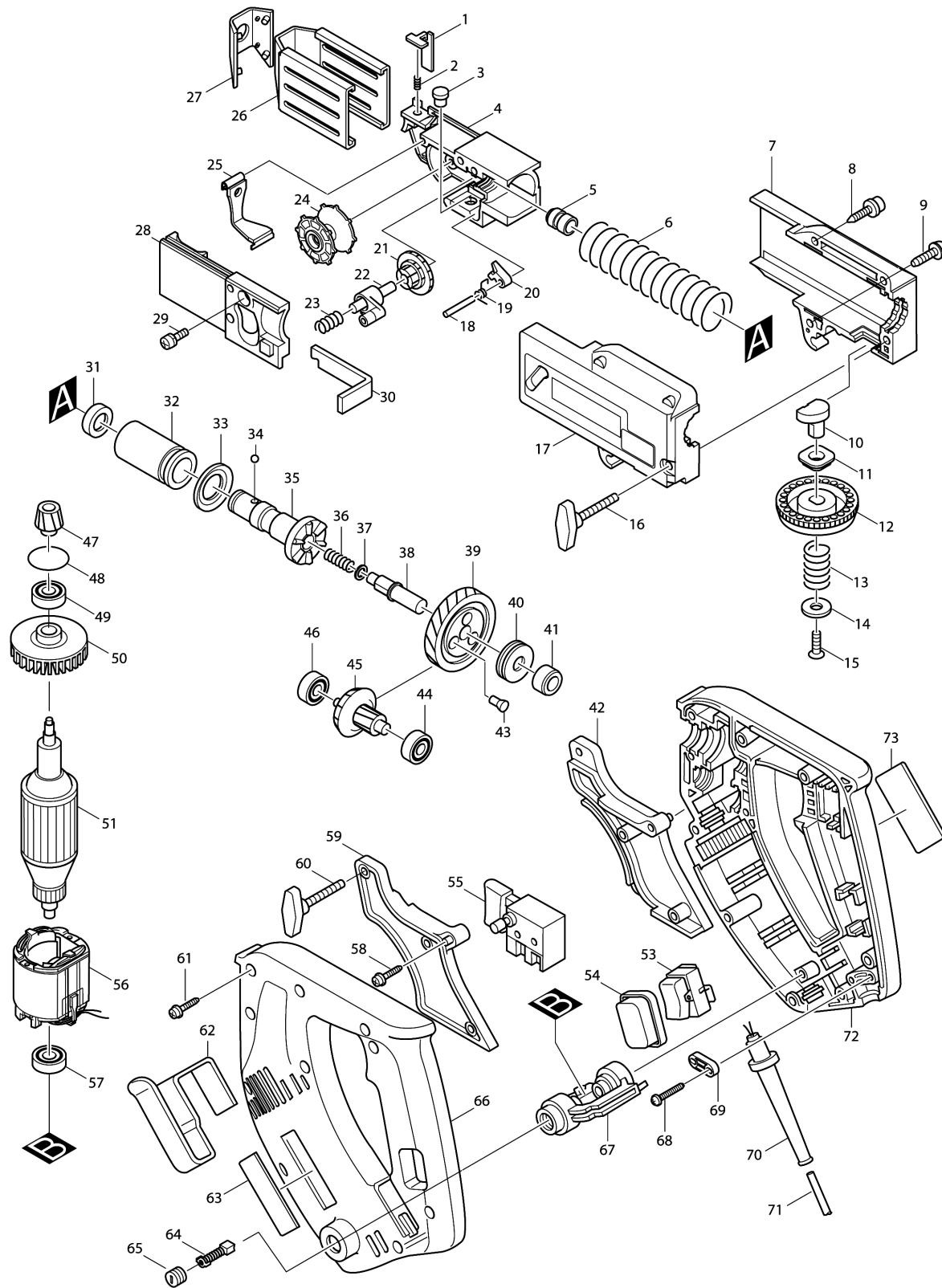

Model No.6834 AUTO FEED SCREWDRIVER

Item	Parts No.	Description	I/C	Qty	New/Old	Opt. 1	Opt. 2	Note
001	344625-3	LEVER		1				
002	233211-4	COMPRESSION SPRING 2		1				
003	256451-7	PIN 6		1				
004	416500-4	FEEDER BOX		1				
005A_	257687-1	SLEEVE 5		1	*			
005A1	257685-5	SLEEVE 5	S	1				
006	233210-6	COMPRESSION SPRING 21		1				
007	182998-4	CASING SET		1	*			
C10	816282-2	INDICATION LABEL		1	*			
C20	818844-2	INDICATION LABEL		1	*			
C30	818554-1	INDICATION LABEL		1	*			
D10		INC. 17			*			
007-1	188213-4	CASING SET	S	1				
C10	816282-2	INDICATION LABEL		1				
C20	804947-8	INDICATION LABEL		1				
C30	818554-1	INDICATION LABEL		1				
008	266045-0	TAPPING SCREW 4X20		2				
009	266020-6	TAPPING SCREW 4X12		1				
010	310061-5	SHIFTER PIN		1	*			
010-1	310091-6	SHIFTER PIN	S	1				
011	257686-3	SLEEVE 8		1				
012	416517-7	KNOB 42		1	*			
012-1	417056-0	DIAL 42	S	1				
013	233089-5	COMPRESSION SPRING 12		1	*			
013-1	213105-9	O RING 11	S	1				
014	267117-4	FLAT WASHER 6		1	*			
014-1	267201-5	FLAT WASHER 6	S	1				
015	912117-6	COUNTERSUNK HEAD SCREW M4X12		1				
016	265732-8	SCREW M4X28		1	*			
016-1	265778-4	THUMB SCREW M4X28	<	1	*			
016-2	265779-2	THUMB SCREW M4X28	<	1				
017	182998-4	CASING SET		1	*			
C10	816282-2	INDICATION LABEL		1	*			
C20	818844-2	INDICATION LABEL		1	*			
C30	818554-1	INDICATION LABEL		1	*			
D10		INC. 7			*			
017-1	188213-4	CASING SET	S	1				
C10	816282-2	INDICATION LABEL		1				
C20	804947-8	INDICATION LABEL		1				
C30	818554-1	INDICATION LABEL		1				
018	256158-5	PIN 3		1				
019	231636-6	TORSION SPRING 4		1				

Please order the parts with part number.

Print Date 18/6/2019

Model No.6834 AUTO FEED SCREWDRIVER

Item	Parts No.	Description	I/C	Qty	New/Old	Opt. 1	Opt. 2	Note
020	310062-3	STOPPER		1				
021	226344-2	SPUR GEAR 16		1				
022	152580-3	RATCHET ARM COMPLETE		1				
023	233212-2	COMPRESSION SPRING 6		1				
024	416518-5	WHEEL		1				
025	162201-9	DUST COVER		1				
026	344628-7	STOPPER BASE		1				
027	421617-0	CAP		1	*			
027-1	421617-0	CAP	X	1				
028	152581-1	BOX COVER COMPLETE		1				
029	911133-5	PAN HEAD SCREW M4X18		1				
030	344627-9	PLATE		1				
031	421467-3	DUST COVER		1				
032A_	214168-8	PLANE BEARING 14		1				
033	421618-8	RING 15		1				
034	216001-0	STEEL BALL 3.5		1				
035A_	323765-0	SPINDLE		1	*			
035A1	153741-8	SPINDLE COMPLETE	S	1				
036	233096-8	COMPRESSION SPRING 5		1	*			
036-1	233393-2	COMPRESSION SPRING 8	S	1				
037	267184-9	FLAT WASHER 6		1	*			
037-1	267277-2	FLAT WASHER 8	S	2				
038	268032-5	PIN		1	*			
039	226486-2	HELICAL GEAR 59		1	*			
039-1	152622-3	GEAR COMPLETE	X	1	*			
039-2	152995-4	GEAR COMPLETE	S	1	*			
039-3	153739-5	GEAR COMPLETE	S	1				
040	212042-4	THRUST NEEDLE BEARING 821		1				
041	214028-4	PLANE BEARING 8		1				
042	182984-5	SCREW GUIDE SET		1				
D10		INC. 59						
043	256439-7	PIN 4		3	*			
043-1	256467-2	SHOULDER PIN 4	S	3				
044	211014-6	BALL BEARING 606		1				
045	226823-0	GEAR COMPLETE 9-22		1				
046	211014-6	BALL BEARING 606		1				
047	226704-8	SPIRAL BEVEL GEAR 15		1				
048	213008-7	O RING 22.4		1	*			
048-1	213380-7	O RING 24	<	1				
049	211061-7	BALL BEARING 6000LLB		1				
050	241869-5	FAN 55		1				
051A_	517063-4	ARMATURE ASS'Y 220V		1				

Please order the parts with part number.

Print Date 18/6/2019

Model No.6834 AUTO FEED SCREWDRIVER

Item	Parts No.	Description	I/C	Qty	New/Old	Opt. 1	Opt. 2	Note
D10		INC. 49,50,57						
053	651569-3	SWITCH VLX13		1				
054	421621-9	DUST COVER		1				
055	651283-1	SWITCH SGEL208C		1				
056A_	633258-2	FIELD 220V		1				
057	211026-9	BALL BEARING 627LLB		1	*			
057-1	210025-8	BALL BEARING 627LLB	O	1				
058	266045-0	TAPPING SCREW 4X20		2				
059	182984-5	SCREW GUIDE SET		1				
D10		INC. 42						
060	265732-8	SCREW M4X28		1	*			
060-1	265778-4	THUMB SCREW M4X28	<	1	*			
060-2	265779-2	THUMB SCREW M4X28	<	1				
061	266045-0	TAPPING SCREW 4X20		10				
062	344056-6	HOOK		1				
063	819063-3	MAKITA LABEL		1				
064A_	191940-4	CARBON BRUSH CB-411		1				
065	643550-8	BRUSH HOLDER CAP 5-8		2				
066	182601-7	HOUSING SET		1				
D10		INC. 63,72						
067	152433-6	HOLDER ARM CPMPLETE		1				
C10	643932-4	BRUSH HOLDER 6X9		2				
068	265995-6	TAPPING SCREW 4X18		2				
069B_	687052-4	STRAIN RELIEF		1				
070	682502-4	CORD GUARD 8-85		1				
071G1	695034-2	POWER SUPPLY CORD 1.0-2-4.0		1				
072	182601-7	HOUSING SET		1				
D10		INC. 63,66						
073	859469-3	NAME PLATE 6834		1				
074	257694-4	SLEEVE 4		1	*			
A01A_	784239-0	PHILLIPS BIT 2-141		3	*			
A01A1	784249-7	+ BIT 2-141	S	3				
A02	824421-0	PLASTIC CARRYING CASE		1				
C10	182935-8	SLIDE LATCH (R.L) SET		1				
E01A_	645253-0	NOISE SUPPRESSOR		1				
E02	652259-1	CLAMP WASHER		4	*			
E04	654077-3	INSULATED TERMINAL FK2-M3D-5.5		2				
E05	646049-2	CHOKE COIL		1				
E06	646050-7	CHOKE COIL		1				
E07	654015-5	EARTH TERMINAL		1				

Please order the parts with part number.

Print Date 18/6/2019