

# Model No.5016NB CHAIN SAW 375MM

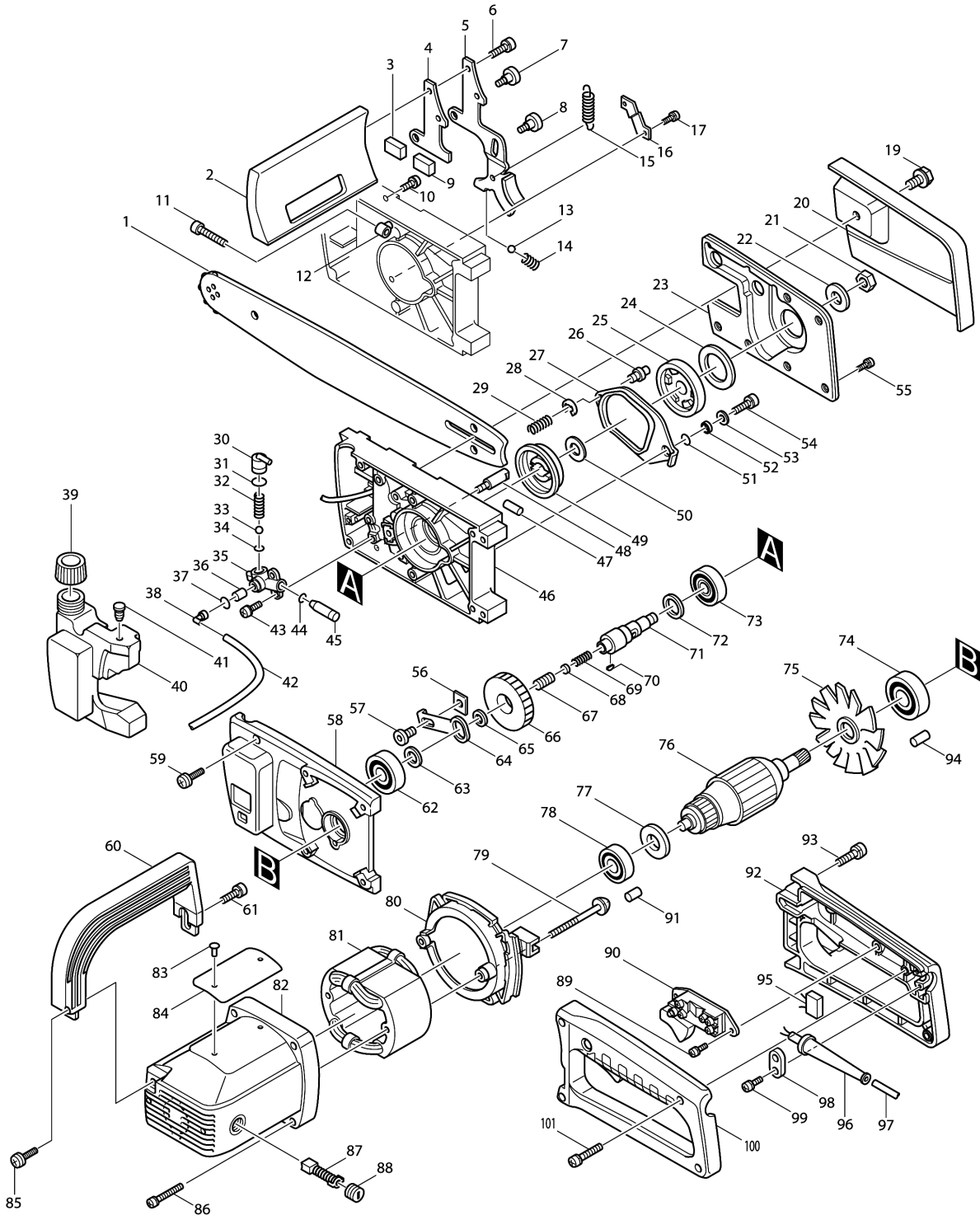



## Model No.5016NB CHAIN SAW 375MM

Item	Parts No.	Description	I/C	Qty	New/Old	Opt. 1	Opt. 2	Note
001	168148-5	GUIDE BAR		1				
002	155778-1	PROTECTOR COMPLETE		1				
C10	817801-7	CAUTION LABEL		1				
003	423120-7	PACKING		1				
004	342905-1	SUPPORTER PLATE		1				
005	168146-9	BRAKE LEVER		1				
006	911221-8	PAN HEAD SCREW M5X16		2				
007	265861-7	HEX. SOCKET HEAD BOLT M6		1				
008	265862-5	HEX. SOCKET HEAD BOLT M6		1				
009	423120-7	PACKING		1				
010-1	911213-7	PAN HEAD SCREW M5X12		1				
011	251426-1	- FLAT HEAD SCREW M5X40		1	*			
011-1	265062-7	PAN HEAD SCREW M5X40	O	1				
012	325549-2	ADJUST PIN		1				
013	216011-7	STEEL BALL 5.6		1				
014-1	231445-3	COMPRESSION SPRING 4		1				
015-1	231778-6	TENSION SPRING 9		1				
016	342870-4	COVER PLATE		1				
017	911111-5	PAN HEAD SCREW M4X10 WITH W		2				
019	251697-0	HEX. FLANGE HEAD BOLT M8X17		1				
020	342871-2	CHAIN COVER		1				
021	252043-0	HEX. NUT M8-13		1				
022	267009-7	FLAT WASHER 8		1				
023-1	155751-1	DUST COVER COMPLETE		1				
024	213417-0	DUST SEAL 30		1				
025	152274-0	SPROCKET COMPLETE		1				
C10	214052-7	PLANE BEARING 10		1				
026	256421-6	PIN 6		1				
027	342869-9	CLUTCH PRESSURE		1				
028	961017-7	STOP RING E-3		1				
029	231372-4	COMPRESSION SPRING 5		1				
030	410525-0	NOZZLE B		1				
031	213007-9	O RING 8		1				
032-1	231400-5	COMPRESSION SPRING 3		1				
033-1	216001-0	STEEL BALL 3.5		1				
034	213022-3	O RING 3		1				
035-1	134374-8	CASING ASS'Y		1				
C10	410526-8	CASING		1				
036-1	423135-4	FILTER		1				
037	213054-0	O RING 9		1				
038	410524-2	NOZZLE A		1				

Please order the parts with part number.

Print Date 17/6/2019

## Model No.5016NB CHAIN SAW 375MM

Item	Parts No.	Description	I/C	Qty	New/Old	Opt. 1	Opt. 2	Note
039	242042-0	CAP		1				
040-2	134374-8	CASING ASS'Y		1				
C10	410526-8	CASING		1				
041	421298-0	CHECK VALVE		1				
042-1	412072-7	TUBE 3		1				
043	911118-1	PAN HEAD SCREW M4X12		3				
044	213022-3	O RING 3		2				
045-2	321946-0	PLUNGER		1				
046	157517-5	GEAR HOUSING		1				
047	256152-7	PIN 6		1				
048	321396-9	CHAIN CATCHER		1				
049	223067-3	CLUTCH CAM		1				
050	253878-2	FLAT WASHER 10		1				
051	257113-0	RING 5		1				
052	253308-3	THIN WASHER 6		1				
053	253184-5	FLAT WASHER 5		1				
054	911221-8	PAN HEAD SCREW M5X16		1				
055	911111-5	PAN HEAD SCREW M4X10 WITH W		6				
056	342874-6	SLIDER PLATE		1				
057	265863-3	HEX. SOCKET HEAD BOLT M6		1				
058	157556-5	GEAR HOUSING COVER		1				
C10	263002-9	RUBBER PIN 4		1				
C20	263005-3	RUBBER PIN 6		1				
C30	817800-9	CAUTION LABEL		1				
059	911231-5	PAN HEAD SCREW M5X20		2				
060-1	273620-5	GRIP		1				
061	911221-8	PAN HEAD SCREW M5X16		2				
062	211101-1	BALL BEARING 6001LLB		1				
063	253084-9	FLAT WASHER 12		1				
064	342873-8	SLIDER		1				
065	253771-0	FLAT WASHER 16		1				
066	221741-7	HELICAL GEAR 53		1				
067	913426-6	SET SCREW M8X16		1				
068	342876-2	PLATE		1				
069	231271-0	COMPRESSION SPRING 4		1				
070	254032-1	WOODRUFF KEY 5		1				
071	321860-0	SPINDLE		1				
072	267011-0	FLAT WASHER 17		1				
073	211251-2	BALL BEARING 6003LLB		1				
074	211106-1	BALL BEARING 6201LLB		1				
075	241093-0	FAN 97		1				
076D_	514797-0	ARMATURE ASS'Y 220V		1	*			

Please order the parts with part number.

Print Date 17/6/2019

## Model No.5016NB CHAIN SAW 375MM

Item	Parts No.	Description	I/C	Qty	New/Old	Opt. 1	Opt. 2	Note
D10		INC. 74,75,77,78			*			
076D1	514557-0	ARMATURE ASS'Y 220V	O	1	*			
D10		INC. 74,75,77,78			*			
076D2	514797-0	ARMATURE ASS'Y 220V	X	1				
D10		INC. 74,75,77,78						
077-1	681624-7	INSULATION WASHER		1	*			
077-2	681635-2	INSULATION WASHER	O	1				
078	211068-3	BALL BEARING 6200LB		1				
079-1	911295-9	PAN HEAD SCREW M5X70		2				
080	410519-5	BAFFLE PLATE		1				
081C_	524763-9	FIELD ASS'Y 220V		1				
C10	654020-2	RING TERMINAL		2				
C20	654502-4	CONNECTOR P-2		2				
082	157516-7	MOTOR HOUSING		1				
C10	643653-8	BRUSH HOLDER 6.5-13.5		2				
C20	913206-0	SET SCREW M5X8		2				
C30	263013-4	RUBBER PIN 4		1				
083	953106-2	RIVET 0-5		2				
084	855235-6	NAME PLATE 5016NB		1				
085	911231-5	PAN HEAD SCREW M5X20		1				
086	911273-9	PAN HEAD SCREW M5X50		4				
087-1	181044-0	CARBON BRUSH CB-153		1				
088	643650-4	BRUSH HOLDER CAP 6.5-13.5		2	*			
088-1	643650-4	BRUSH HOLDER CAP 6.5-13.5	O	2				
089	911101-8	PAN HEAD SCREW M4X6		2				
090B1	651040-7	SWITCH HPAH2-22S		1				
091	263013-4	RUBBER PIN 4		1				
092A1	181861-8	HANDLE SET		1				
C10	410663-8	STOPPER PIN		1				
D10		INC. 100						
093	911228-4	PAN HEAD SCREW M5X18		4				
094	263002-9	RUBBER PIN 4		1				
095B_	645200-1	NOISE SUPPRESSOR		1				
096	682505-8	CORD GUARD 10-90		1				
097G_	665527-3	POWER SUPPLY CORD 1.00-2-5.0		1				
098A_	687001-1	STRAIN RELIEF		1				
099-1	911133-5	PAN HEAD SCREW M4X18		2				
100A1	181861-8	HANDLE SET		1				
C10	410663-8	STOPPER PIN		1				
D10		INC. 92						
101	911153-9	PAN HEAD SCREW M4X28		2				
102	410630-3	SAFETY COVER		1				

Please order the parts with part number.

Print Date 17/6/2019

## Model No.5016NB CHAIN SAW 375MM

Item	Parts No.	Description	I/C	Qty	New/Old	Opt. 1	Opt. 2	Note
103	911238-1	PAN HEAD SCREW M5X22		1				
400	791140-2	CHAIN BLADE 16		1	*			
401-1	182229-1	OIL SUPPLY 100CC		1				
D10		INC. 402						
402	242012-9	OIL SUPPLY NOZZLE		1				
403	744003-1	FILE 4		1				
404	782212-4	SOCKET WRENCH 13		1				
405	783001-0	(-) SCREWDRIVER 6		1				
406-1	414537-5	GUIDE BAR CASE		1				
901	158024-1	HOOK COMPLETE		1				

Please order the parts with part number.

Print Date 17/6/2019