

Model No.3708FC TRIMMER

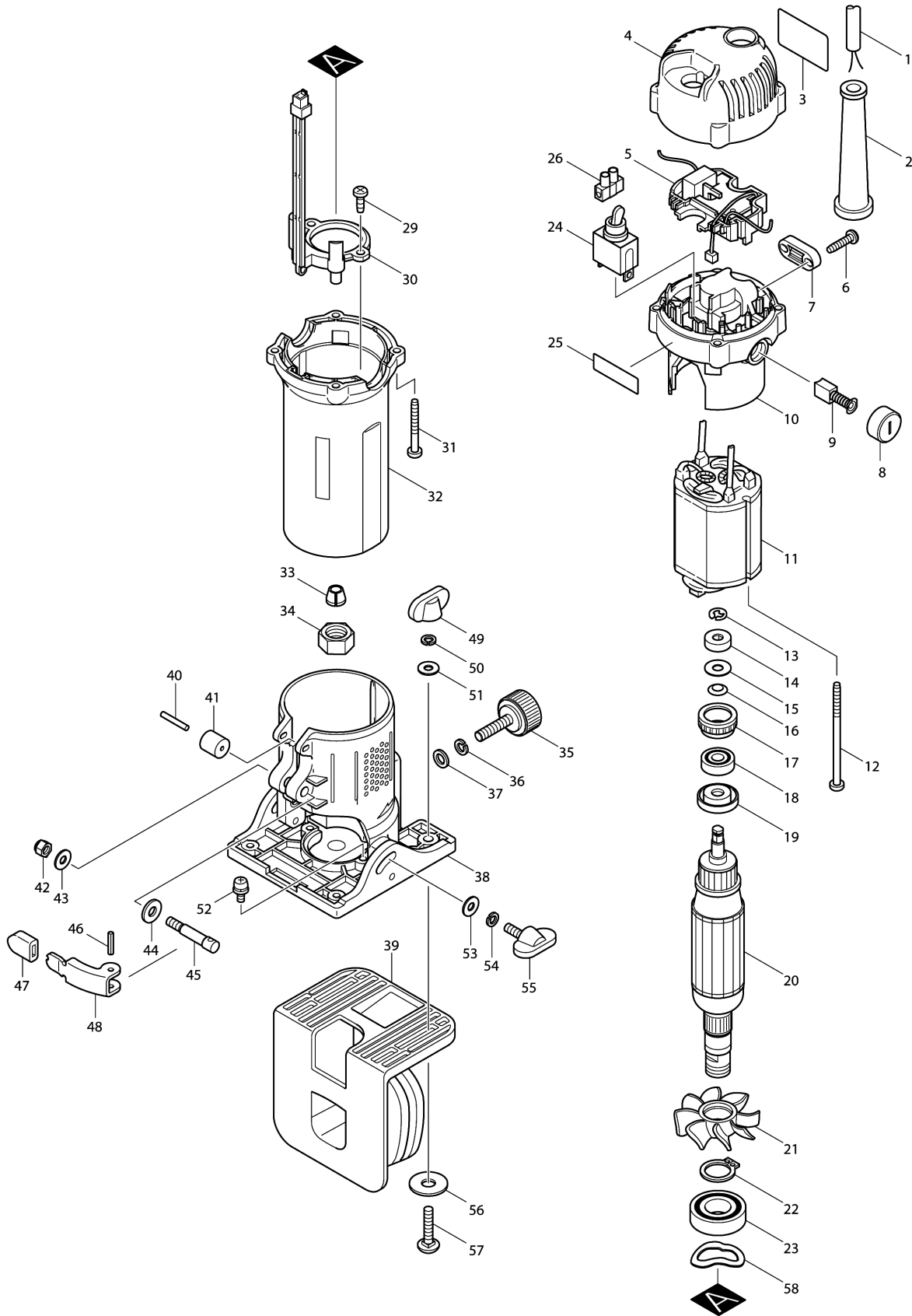

Model No.3708FC TRIMMER

Item	Parts No.	Description	I/C	Qty	New/Old	Opt. 1	Opt. 2	Note
001	665394-6	POWER SUPPLY CORD 1.0-2-2.5		1				
002	682502-4	CORD GUARD 8-85		1				
003	853541-3	NAME PLATE 3708FC		1				
004	417747-3	REAR COVER		1				
005	631487-1	CONTROLLER		1				
006	265995-6	TAPPING SCREW 4X18		2				
007	687052-4	STRAIN RELIEF		1				
008	643928-5	BRUSH HOLDER CAP		2				
009	191940-4	CARBON BRUSH CB-411		1				
010	183417-3	MOTOR REAR HOUSING		1				
C10	643981-1	BRUSH HOLDER 6X9		2				
D10		INC. 25						
011	595064-2	FIELD ASS'Y 230-240V		1				
C10	654100-4	RING TERMINAL		2				
C20	654501-6	CONNECTOR P-1.25		2				
012	266004-4	TAPPING SCREW 4X70		2				
013	259039-2	SELF LOCK 6		1				
014A	688117-5	MAGNET SLEEVE		1	*			
014-1A	688174-3	MAGNET SLEEVE	<	1	*			
014-1B	688174-3	MAGNET SLEEVE		1	*			
014-2	688117-5	MAGNET SLEEVE	O	1				
015	253332-6	THIN WASHER 6		1				
016	267756-0	WAVE WASHER 6		1				
017	421494-0	RUBBER RING 19		1				
018	210017-7	BALL BEARING 607DDW		1				
019	681636-0	INSULATION WASHER		1				
020A	517569-2	ARMATURE ASS'Y 230-240V		1	*			
D10		INC. 18,19,21,22			*			
020-1A	517619-3	ARMATURE ASS'Y 240V	<	1				
D10		INC. 18,19,21,22						
020-1B	517619-3	ARMATURE ASS'Y 240V		1				
D10		INC. 18,19,21,22						
021	240049-0	FAN 48		1				
022	961055-9	RETAINING RING S-15		1				
023	211236-8	BALL BEARING 6002DDW		1				
024	651423-1	SWITCH		1				
025	819720-3	MAKITA LABEL		1				
026	654544-8	TERMINAL BLOCK		1				
029	251991-0	+ TAPPING SCREW M4X12		2				
030	631480-5	LED CIRCUIT		1				
031	266053-1	TAPPING SCREW 4X35		4				
032	153347-2	MOTOR HOUSING COMPLETE		1				

Please order the parts with part number.

Print Date 3/6/2019

Model No.3708FC TRIMMER

Item	Parts No.	Description	I/C	Qty	New/Old	Opt. 1	Opt. 2	Note
C10	816274-1	SCALE LABEL "MM"		1				
033A	763607-0	COLLET CONE 6MM		1	*			
033-1A	763607-0	COLLET CONE 6MM	O	1				
033-1B	763607-0	COLLET CONE 6MM		1				
034	763606-2	COLLET NUT 6		1				
035	251814-2	SCREW M6X18		1				
036	942151-2	SPRING WASHER 6		1				
037	941151-9	FLAT WASHER 6		1				
038	153351-1	BASE COMPLETE		1	*			
038-1	143655-9	BASE COMPLETE	<	1				
039	414304-8	TRIMMER SHOE		1				
040	256158-5	PIN 3		1	*			
040-1	256221-4	PIN 3	<	1				
041	421566-1	ROLLER W/O PIN		1				
042	252103-8	HEX. LOCK NUT M5-8		1				
043	941101-4	FLAT WASHER 5		1				
044	267214-6	FLAT WASHER 6		1				
045	324243-3	SUPPORT PIN		1				
046	951060-4	SPRING PIN 3-14		1				
047	421818-0	RUBBER CAP		1				
048	345229-4	LOCK LEVER		1				
049	252646-0	WING NUT M5		2				
050	942101-7	SPRING WASHER 5		2				
051	941101-4	FLAT WASHER 5		2				
052	911114-9	PAN HEAD SCREW M4X10		2				
053	941101-4	FLAT WASHER 5		2				
054	942101-7	SPRING WASHER 5		2				
055	265740-9	SCREW M5X15		2				
056	267248-9	FLAT WASHER 8		2				
057	923241-0	CAP SQUARE NECK BOLT M5X25		2				
058	253905-5	WAVE WASHER 23		1				
A01A	122389-7	TRIMMER GUIDE ASS'Y		1	*			
C10	312650-2	TRIMMER GUIDE		1	*			
D10		INC. A02-A10			*			
A01-1A	122703-7	TRIMMER GUIDE ASS'Y	O	1				
C10	317789-6	TRIMMER GUIDE		1				
D10		INC A02-A08,A10						
A01-1B	122703-7	TRIMMER GUIDE ASS'Y		1				
C10	317789-6	TRIMMER GUIDE		1				
D10		INC A02-A08,A10						
A02A	251819-2	SCREW M6		1	*			
A02-1A	265764-5	THUMB SCREW M6	O	1				

Please order the parts with part number.

Print Date 3/6/2019

Model No.3708FC TRIMMER

Item	Parts No.	Description	I/C	Qty	New/Old	Opt. 1	Opt. 2	Note
A02-1B	265764-5	THUMB SCREW M6		1				
A03A	912116-8	COUNTERSUNK HEAD SCREW M4X12		1	*			
A03-1A	265135-6	+ COUNTERSUNK HEAD SCREW M4X10	O	1				
A03-1B	265135-6	+ COUNTERSUNK HEAD SCREW M4X10		1				
A04	341136-9	HOOK		1				
A05A	251420-3	- FLAT HEAD SCREW M5		1	*			
A05-1A	251471-6	- FLAT HEAD SCREW M5	O	1				
A05-1B	251471-6	- FLAT HEAD SCREW M5		1				
A06A	323495-3	ROLLER 11		1	*			
A06-1A	324378-0	ROLLER 11	O	1				
A06-1B	324378-0	ROLLER 11		1				
A07A	312396-0	GUIDE HOLDER		1	*			
A07-1A	317788-8	GUIDE HOLDER	O	1				
A07-1B	317788-8	GUIDE HOLDER		1				
A08	941151-9	FLAT WASHER 6		1				
A09A	253903-9	WAVE WASHER 6		1	*			
A10A	251815-0	SCREW M6X25		1	*			
A10-1A	265763-7	THUMB SCREW M6X25	O	1				
A10-1B	265763-7	THUMB SCREW M6X25		1				
A11	343577-5	TEMPLET GUIDE 10		1				
A12	781003-0	WRENCH 10		1	*			
A12-1	781036-5	WRENCH 10	O	1				
A13	781008-0	WRENCH 17		1				
A14	251919-8	CAP SQUARE NECK BOLT M6X20		1				
A15	253903-9	WAVE WASHER 6		1				
A16	934301-3	WING NUT M6		1				
A17	941151-9	FLAT WASHER 6		1				
A18A	793076-1	STRAIGHT BIT 6		1	*			
A18-1A	D-09167	STRAIGHT BITS 6	O	1				
A18-1B	D-09167	STRAIGHT BITS 6		1				
A19	343627-6	STRAIGHT GUIDE		1				
A20	421345-7	JOINT		1				
A21	163299-9	FLEXIBLE HOSE		1				
A22	251358-2	+ PAN HEAD SCREW M4X8		1				
A23	343593-7	GUIDE PLATE		1				
A24B	821550-0	CONNECTOR PLASTIC CASE (TYPE2)		1				
C10	453974-8	LATCH		4				
A25B	803F91-4	3708FCJ INDICATION LABEL		1				
A26B	803F92-2	3708FCJ PLASTIC CASE LABEL		2				
A27B	837674-2	INNER TRAY		1				

Please order the parts with part number.

Print Date 3/6/2019