

SERVICE DRAWING

MODEL NO. 194943-7

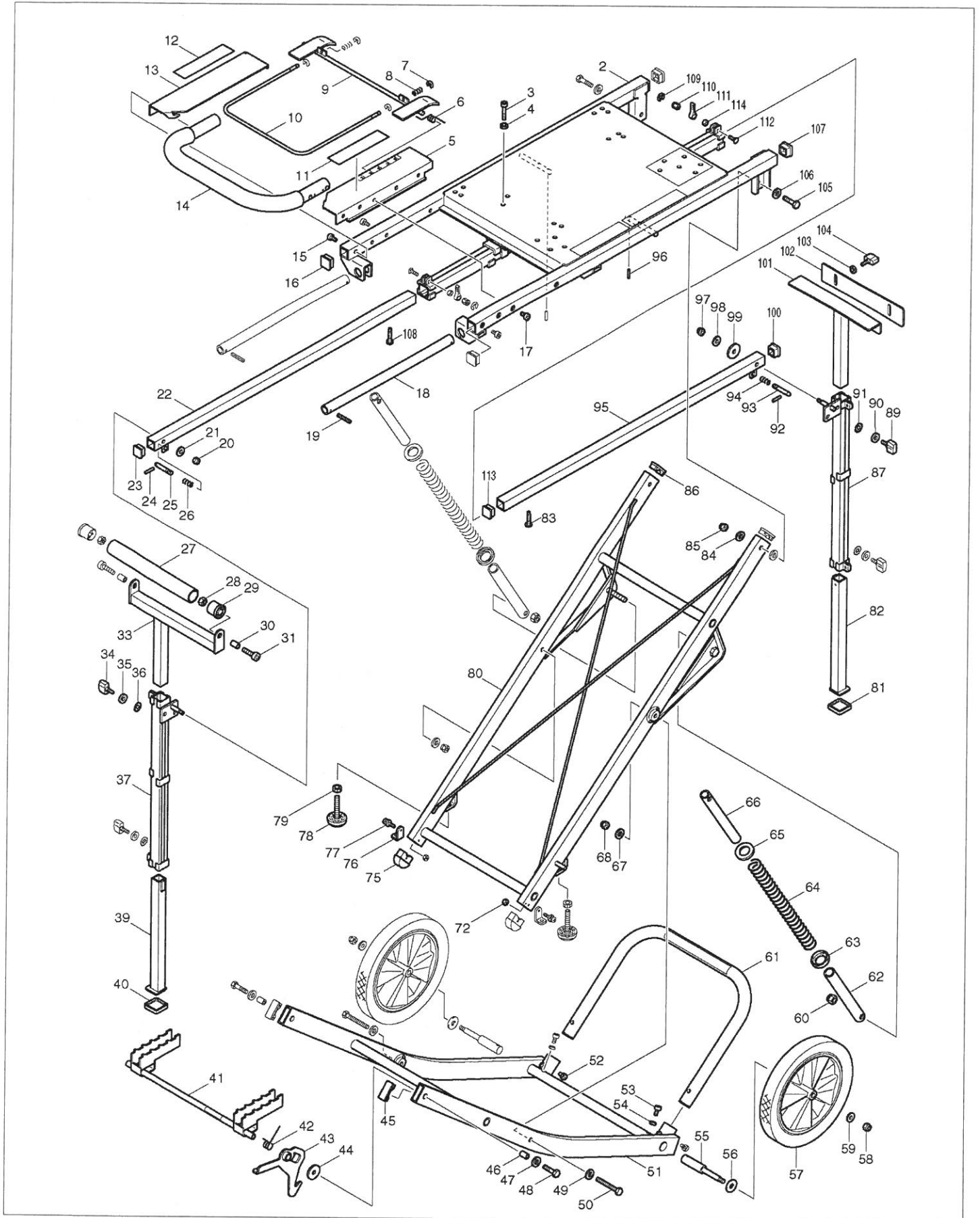

SPARE PARTS LIST

PAGE 1

MODEL NO. 194943-7

ITEM	PART NO.	DESCRIPTION	QTY	NOTE
002	140202-7	FRAME COMPLETE	1	
003	265503-3	HEX.BOLT M8X50	4	
004	267371-0	FLAT WASHER 8	4	
005	158396-4	RATCHET COVER A COMPLETE	1	
006	233517-0	TORSION SPRING 15	1	
007	259044-9	STOP RING E-7	4	
008	231418-6	COMPRESSION SPRING 9	2	
009	165474-3	STOPPER	1	
010	324827-7	DOWN SHIFT LEVER	1	
011	819173-6	MAKITA LOGO LABEL	1	
012	819173-6	MAKITA LOGO LABEL	1	
013	158605-1	RATCHET COVER B COMPLETE	1	
014	158394-8	HANDLE COMPLETE	1	
015	266447-0	HEX. SOCKET HEAD BOLT M8X30	4	
016	450197-9	CAP 31	2	
017	266447-0	HEX. SOCKET HEAD BOLT M8X30	4	
018	331787-6	PIPE 25-458	2	
019	951225-8	SPRING PIN 6-40	4	
020	931402-8	HEX. NUT M8	2	
021	267367-1	FLAT WASHER 10	2	
022	165473-5	EXTENSION ARM	1	
023	450196-1	CAP 28	1	
024	951113-9	SPRING PIN 4-18	1	
025	324831-6	PIN 10-60	1	
026	231226-5	COMPRESSION SPRING 11	1	
027	331791-5	PIPE 38-300	1	
028	264015-3	HEX. NUT M10	2	
029	450195-3	CAP 38	2	
030	257589-1	SLEEVE 10	2	
031	266434-9	HEX.SOCKET HEAD BOLT M10X40	2	
033	165471-9	ROLLER SUPPORTER	1	
034	265777-6	THUMB SCREW M8X20	2	
035	253752-4	FLAT WASHER 8	2	
036	267808-7	TOOTHED LOCK WASHER 8	2	
037	165467-0	PIPE 31-540	1	
039	158668-7	FOOT PIPE 28 COMPLETE INC. 40	1	
040	424054-7	CUSHION	1	
041	158397-2	TOP GUIDE COMPLETE	1	
042	233518-8	TORSION SPRING 16	1	
043	165497-1	LOCK LEVER	1	
044	253134-0	FLAT WASHER 11	2	
045	418846-4	CAP	2	
046	257589-1	SLEEVE 10	2	
047	267372-8	FLAT WASHER 10	2	
048	265574-0	HEX. BOLT M10X40	2	
049	267372-8	FLAT WASHER 10	2	
050	265575-8	HEX. BOLT M10X75	2	
051	165477-7	LEG B	1	
052	266438-1	HEX. SOCKET HEAD BOLT M8X16	2	
053	266438-1	HEX. SOCKET HEAD BOLT M8X16	2	
054	267371-0	FLAT WASHER 8	2	
055	324830-8	WHEEL SHAFT	2	
056	253004-3	FLAT WASHER 13	2	
057	168448-3	WHEEL 300	2	
058	252130-5	HEX. LOCK NUT M10-17	2	
059	267367-1	FLAT WASHER 10	2	
060	264012-9	HEX. LOCK NUT M12-19	2	

SPARE PARTS LIST

PAGE 2

MODEL NO. 194943-7

ITEM	PART NO.	DESCRIPTION	QTY	NOTE
061	158519-4	FOOT ARM COMPLETE	1	
062	331789-2	PIPE 28-230	2	
063	345849-4	SPRING HOLDER	2	
064	234033-5	COMPRESSION SPRING 29	2	
065	345849-4	SPRING HOLDER	2	
066	331790-7	PIPE 25-230	2	
067	267372-8	FLAT WASHER 10	2	
068	252130-5	HEX. LOCK NUT M10-17	2	
072	264014-5	HEX. NUT M5	2	
075	418847-2	FOOT	2	
076	345695-5	FIX PLATE	2	
077	265183-5	PAN HEAD SCREW M5X20	2	
078	266353-9	ADJUST BOLT M12	2	
079	252651-7	NUT M12	2	
080	158615-8	LEG A COMPLETE	1	
081	424054-7	CUSHION	1	
082	158668-7	FOOT PIPE 28 COMPLETE INC. 81	1	
083	266448-8	HEX. SOCKET HEAD BOLT M5X16	1	
084	267372-8	FLAT WASHER 10	2	
085	252130-5	HEX. LOCK NUT M10-17	2	
086	418846-4	CAP	2	
087	165467-0	PIPE 31-540	1	
089	265777-6	THUMB SCREW M8X20	2	
090	253752-4	FLAT WASHER 8	2	
091	267808-7	TOOTHED LOCK WASHER 8	2	
092	951113-9	SPRING PIN 4-18	1	
093	324831-6	PIN 10-60	1	
094	231226-5	COMPRESSION SPRING 11	1	
095	165473-5	EXTENSION ARM	1	
096	951113-9	SPRING PIN 4-18	4	
097	931402-8	HEX. NUT M8	2	
098	267367-1	FLAT WASHER 10	2	
099	253134-0	FLAT WASHER 11	2	
100	450196-1	CAP 28	1	
101	165470-1	CONSTANT DIMENSIONS SUPPORTER	1	
102	345851-7	CONSTANT DIMENSIONS PLATE	1	
103	267371-0	FLAT WASHER 8	2	
104	265777-6	THUMB SCREW M8X20	2	
105	265574-0	HEX. BOLT M10X40	2	
106	267372-8	FLAT WASHER 10	2	
107	450197-9	CAP 31	2	
108	266448-8	HEX. SOCKET HEAD BOLT M5X16	1	
109	259043-1	RETAINING RING E TYPE 8	2	
110	252133-9	HEX. NUT M6	2	
111	272259-1	LEVER 40	2	
112	266435-7	PAN HEAD SQUARE NECK BOLTM6X20	2	
113	450196-1	CAP 28	1	
114	257293-2	RING 7	2	
A01	781040-4	WRENCH 13	1	
A02	783204-6	HEX. WRENCH 6	1	